

TECHNICAL BULLETIN



Engine Crankcase – Oil Leaks – Sealing Procedure

12-53

MODEL All V12

DATE 12/94

ISSUE:

Oil leakage at the crankcase joints of V12 engines.

ACTION:

Before replacing any gaskets to correct crankcase oil leaks on V12 engines, perform the following:

1. Retorque the oil pan (sump) to sandwich plate, and sandwich plate to engine block bolts to 16 - 20 lb ft (21 - 27 Nm).
2. Clean all residual oil from the engine block, sandwich plate, and oil pan.
3. Road test the vehicle; examine the crankcase gaskets for signs of oil leakage. Oil may also leak upwards along the threads of the bolts securing the baffle tray and sandwich plate and appear on top of the engine block or sandwich plate gasket flanges.

For oil leaks at the oil pan gasket or at the baffle tray and sandwich plate bolts, perform the following:

1. Remove the oil pan.
2. Remove the sandwich plate and baffle tray bolts shown in Illustration 1.
 - XJ12 - 7 bolts
 - XJS V12 - 9 bolts

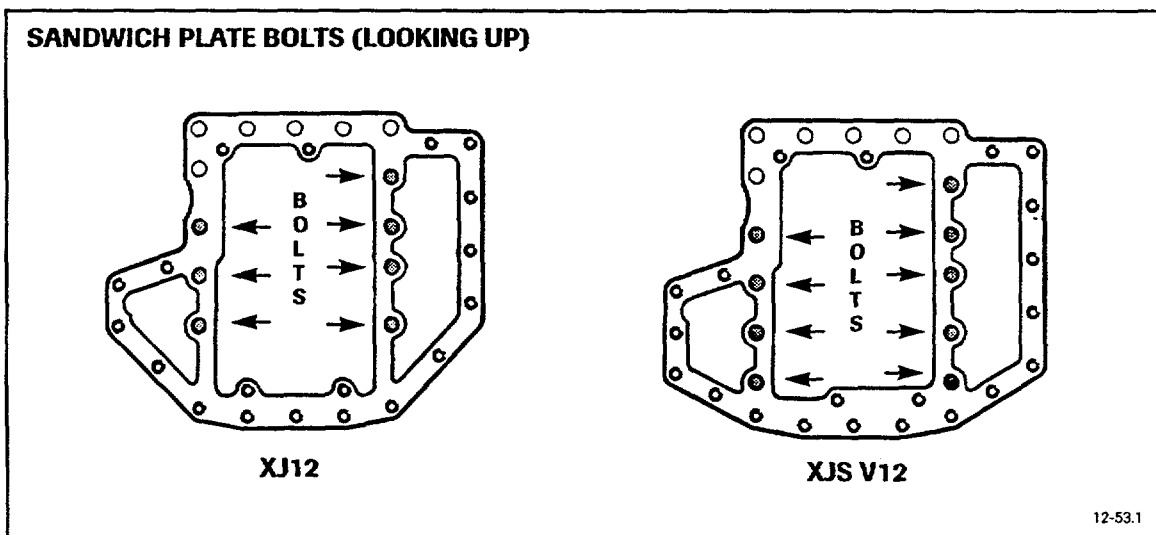

ILLUSTRATION 1

3. Thoroughly clean the bolts and bolt hole threads.
4. Apply Loctite Primer to the bolt hole threads.

Index # **040915**

5. Apply Loctite 545 to the sandwich plate and baffle tray bolts. Install and torque the bolts to 16 - 20 lb ft (21 - 27 Nm).
6. Install the oil pan with a new gasket and torque to 6 - 20 lb ft (21 - 27 Nm).

IMPORTANT: When repairing V12 engines up to the engine numbers listed below, upgrade the fasteners and gaskets according to the information in Service Bulletin 12-35 "Oil Leaks - Improved Gaskets/Bolts - Installation Instructions" published 8/92.

- XJS V12 All up to Engine Number 8S 86317
- XJR-S All up to Engine Number 8W 10641

PARTS INFORMATION:

<u>DESCRIPTION</u>	<u>PART NUMBER</u>
Loctite 545	54531

WARRANTY INFORMATION:

Refer to Section AQ of the appropriate Warranty Codes and Repair Operation Times manual.