

# TECHNICAL BULLETIN



## Fuel Pressure Regulator – Hard Starting/ Long Cranking Time, Hot/Warm Engine – Repair Procedure

**19-28**  
AMENDED  
2/95

MODEL XJ12, XJS Range (V12)

DATE 11/94

Remove and destroy Bulletin 19-28, Date 11/94. Replace with this Bulletin.  
Revisions are marked with a bar and indicated in **Bold Text**.

### ISSUE:

Symptoms of hard starting while hot or warm, with cranking times in excess of 5 seconds, on 1994 MY XJ12 Sedans and 1994 MY XJS Range V12 vehicles within the following VIN ranges.

XJ12	VIN 687219 – 707625
XJS Range (V12)	VIN 190528 – 195120

Damage to the "O" ring that seals the fuel pressure regulator to the fuel pressure regulator housing can cause low fuel pressure during cranking, resulting in this hard starting condition.

### ACTION:

If customers with vehicles within the VIN range complain of hard starting hot or warm, with prolonged cranking time, perform the following diagnostic operation.

1. Depressurize the fuel system following the instructions in Service Manual Section 12, operation 19.50.02.
2. Fit a fuel pressure gauge to the fuel rail.
3. Run, then stop the engine while watching the fuel gauge.
4. If the fuel pressure drops **LESS** than 10 psi one minute after the engine is stopped, the cause of the hard starting is not with the pressure regulator "O" ring
5. If the fuel pressure drops **MORE** than 10 psi one minute after the engine is stopped, perform the following repair procedure.

### REPAIR PROCEDURE

1. Ensure that the radio code is available. Record all preset radio stations (including X-mem) and disconnect the negative cable of the battery.
2. Remove the fuel pressure regulator following the instructions in Service Manual Section 18, operation 19.45.11. Remove the fuel pressure regulator housing (Illustration 1).

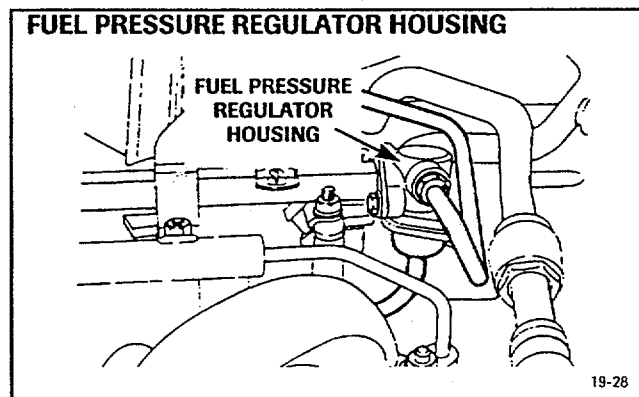

ILLUSTRATION 1

Index # **041915**

3. Examine the fuel pressure regulator "O" ring for damage (Illustration 2).
4. Examine the "O" ring seal bore in the fuel pressure regulator housing for sharp edges or burrs (Illustration 2).
5. If sharp edges or burrs are evident, carefully remove them with a hand tool such as a countersink.
6. Thoroughly clean the fuel pressure regulator housing.
7. Lubricate a new pressure regulator housing to fuel rail "O" ring with petroleum jelly. Fit the "O" ring to the fuel rail and install the fuel pressure regulator housing.

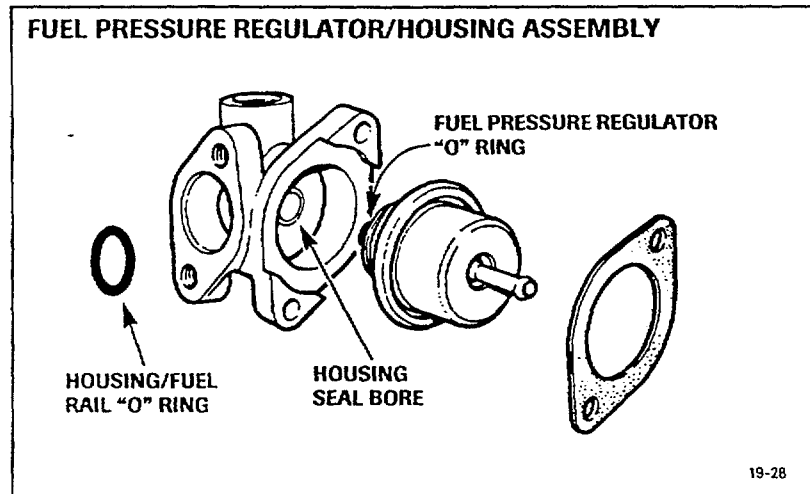

ILLUSTRATION 2

8. Install a NEW fuel pressure regulator
9. Connect the negative cable of the battery.
10. Run the engine and check for fuel leaks. Stop the engine.
11. Observe the fuel pressure gauge for one minute. The fuel pressure should drop no more than 10 psi after the engine has been stopped for one minute.
12. Remove the fuel pressure gauge and check the fuel system for leaks.
13. Recode the radio and reset all radio stations and the clock.

**PARTS INFORMATION:**

<u>DESCRIPTION</u>	<u>PART NUMBER</u>	<u>QTY</u>
Fuel pressure regulator	EBC 10768	1
"O" ring seal - housing to fuel rail	EBC 2207	1

**WARRANTY INFORMATION:**

<u>FAULT CODE</u>	<u>R.O. NUMBER</u>	<u>DESCRIPTION</u>	<u>TIME ALLOWANCE</u>
CL KB BL	19.91.39	XJ12	0.40 hrs.
		XJS (V12)	0.60 hrs.