



BY APPOINTMENT TO
HER MAJESTY QUEEN ELIZABETH II
MANUFACTURERS OF DAIMLER AND JAGUAR CARS
JAGUAR CARS LIMITED COVENTRY



BY APPOINTMENT TO
HER MAJESTY QUEEN ELIZABETH
THE QUEEN MOTHER
MANUFACTURERS OF DAIMLER AND JAGUAR CARS
JAGUAR CARS LIMITED COVENTRY



BY APPOINTMENT TO
HIS ROYAL HIGHNESS THE PRINCE OF WALES
MANUFACTURERS OF DAIMLER AND JAGUAR CARS
JAGUAR CARS LIMITED COVENTRY

Technical Guide

AIR CONDITIONING SYSTEM HFC REFRIGERANT RETROFIT

Contents

Title	Page
Introduction	1
VINs Used In This Guide	2
Gas Reclamation And Charging Equipment	2
Retrofit Kits	2
Post Retrofit Servicing	3
Receiver–Drier Sight Glass	3
If Compressor Failure Should Occur	3
Changing Air–conditioning System Hoses And Pipes	4
General	4
Air–Conditioning Unit Failure	4
Receiver–Drier Failure	4
Oil Compatibility	4
Parts Availability	4
Safety and Correct Working Practices	5
General	5
Use of Recovery and Recycling Unit in Workshop Handling Refrigerant	5
Handling Lubrication Oil	5
System Maintenance	6
Jaguar XJ40 (Pre–90my)	7
Jaguar XJ40 (Post–90MY)	17
Jaguar XJS 5.3 Litre V12	27
Jaguar XJS 6.0 Litre V12	36
Jaguar XJS 3.6 Litre 6 Cylinder (Pre–92MY)	47
Jaguar XJS 4.0 Litre 6 Cylinder (Post–92MY)	54
Jaguar Series III 5.3 Litre V12	64

Hydrofluorocarbon (HFC) R-134a Air-Conditioning Refrigerant Retrofit

Introduction

Jaguar Cars Limited is committed worldwide to protecting the environment and, to this end, has pursued an aggressive, but orderly phase-out of Chlorofluorocarbons (CFCs) R-12 air-conditioning refrigerant which goes beyond the requirements on the Montreal Protocol Convention and other legislation. The phase-out began with the introduction of Hydrofluorocarbon (HFC) R-134a air-conditioning refrigerant on all new vehicles leaving the production line, and is continued in the same aggressive manner with the introduction of a retrofit programme for many existing Jaguar vehicles currently in circulation.

The need to develop and implement a retrofit programme has become more urgent because of the likelihood of R-12 refrigerant becoming a scarce commodity. R-12 refrigerant, which has a high ozone depleting potential, is being removed from the list of approved refrigerants and will cease to be produced by the end of December 1995. R-12 will, therefore, become increasingly rare, and even unobtainable. Vehicles equipped with CFC R-12 systems should continued to be serviced with R-12 refrigerant and only retrofitted with HFC R-134a refrigerant when R-12 is no longer available or cost-effective. All procedures associated with the changeover from R-12 to R-134a must be carried out at the time of changeover to ensure system safety and compatibility.

The retrofit programme will enable dealers worldwide to offer a service which permits the safe reclamation of R-12 refrigerant from the vehicles listed in this Guide and subsequent recharging with R-134a refrigerant.

The retrofit procedure requires that modifications must be carried out to the system to ensure compatibility with R-134a refrigerant. Physical modifications are kept to an absolute minimum, while still observing the need to ensure an environmentally safe and effective system.

The retrofit programme currently extends to the following vehicle models:

Model	VIN range	Compressor type
X 40	507471 to 593883 (Pre-90MY).	Sanden 510
XJ40	593884 to 667578 (Post-90MY).	Sanden 709
5.3 litre V12 XJS	100001 to 188104	Harrison
6.0 litre V12 XJS	188105 to 190527	Sanden 709
3.6 litre 6 cylinder XJS	112586 to 179739 (Pre-92MY)	Harrison
4.0 litre 6 cylinder XJS	179740 to 190527 (Post-92MY)	Sanden 709
5.3 litre V12 Series III	300001 to 500000	Harrison

The scope of the retrofit programme may be widened to cover other vehicles if this proves necessary.

Sufficient information is included in this Technical Guide to enable a technician to carry out the retrofit on Series III 4.2 litre and early XJ40 vehicles fitted with a Harrison compressor. Information contained herein may not necessarily cover these particular vehicle types, but instructions for other vehicles can be manipulated to effect a retrofit on such vehicles in safe and timely manner. It is expected that vehicles of this type are likely to be encountered less frequently than others and, therefore, the demand to perform the retrofit will be limited.

The individual sections that make up this Technical Guide are self-contained and relate to the different vehicle models covered. Reference should be made to the appropriate Service Manual for specific setting figures referred to in this Guide. To carry out a retrofit, identify the appropriate section and action all instructions contained therein.

The instructions given in the following sections relate to the removal of CFC R-12 refrigerant from the air-conditioning system and the subsequent recharging with HFC R-134a refrigerant.

VINs Used In This Guide

All VIN numbers used in this document are assured production build. There may be a number of earlier vehicles encountered, i.e. pre-production.

Gas Reclamation And Charging Equipment

Because there is a possibility that more than one type of R-12 and R-134a air-conditioning charging unit will be available, it has been assumed in these instructions that dealers are familiar with their own particular refrigerant charging and reclamation equipment. Refer to the equipment operating instructions at the appropriate stage in the following operations and observe all warnings and cautions contained therein. Always follow the equipment manufacturer's instructions to ensure that gas is reclaimed, the system is evacuated and that it is correctly recharged; do not omit any part of a procedure.

Retrofit Kits

There are two air-conditioning system retrofit kits currently available. One kit covers XJS vehicles (1976 to 1993.5MY inclusive) and Series III vehicles (post 1984MY). The other covers all XJ40 vehicles (1988 to 1992MY inclusive). The contents of these kits is as follows:

XJS & Series III (JLM11611)

Item	Part No.	Description	Quantity
1	JLM11098	O-ring	2
2	JLM11603	Warning label 134a retrofit	1
3	JLM11604	Compressor centre shaft seal kit	1
4	JLM11605	Ester oil RL100	1
5	JLM11606	Port adaptor $\frac{7}{16}$ low	1
6	JLM11607	Port adaptor $\frac{7}{16}$ high	1
7	JLM11608	Port adaptor $\frac{3}{8}$ high	1
8	JLM11609	Port adaptor $\frac{7}{16}$ low	1
9	KSG108116	O-ring	3
10	MHB7410AA	Receiver-drier bottle	1
11	C41014	Foam	2
12	KSG111116	O-ring	1

XJ40 Prior to 93MY (JLM11610)

Item	Part No.	Description	Quantity
1	JLM11098	O-ring	2
2	JLM11603	Warning label 134a retrofit	1
3	JLM11604	Compressor centre shaft seal kit	1
4	JLM11605	Ester oil RL100	1
5	JLM11606	Port adaptor $\frac{7}{16}$ straight	1
6	JLM11607	Port adaptor $\frac{7}{16}$ high	1
7	JLM11608	Port adaptor $\frac{3}{8}$ high	1
8	JLM11628	Compressor centre shaft seal kit	1
9	KSG108116	O-ring	2
10	MMA7410AA	Receiver-drier bottle	1

Post Retrofit Servicing

Dealers are reminded that they must keep detailed records of retrofits performed so that subsequent servicing of a vehicle which has been converted from R-12 to R-134a is carried out in a safe and proper manner. Records must reflect all modifications made to a vehicle air-conditioning system, particularly any modifications to the compressor. It is imperative that the R-134a warning label is fitted in a prominent position and that it reflects the true condition of the vehicle. Remove, destroy or permanently deface all original labels referring to R-12 refrigerant.

The following should be observed when servicing a retrofit condition vehicle:

Receiver-Drier Sight Glass

Do NOT use the sight glass on the receiver-drier bottle as a method of diagnosing faults on the air-conditioning system (i.e. system levels or leakages); R-134a refrigerant has different characteristics to R-12.

If Compressor Failure Should Occur

Reclaim the R-134a refrigerant from the vehicles air-conditioning system as described in the appropriate section.

Remove the compressor.

Obtain a new R-12 compressor.

Drain the mineral oil from the new compressor.

If a Sanden compressor is being fitted, fit new seals (refer to the retrofit instructions in this Guide).

Flush the compressor with Ester oil to remove traces of mineral oil, then drain the compressor.

Refill the compressor with Ester oil RL100 to the normal charge weight.

Refit the compressor.

Recharge the air-conditioning system with R-134a refrigerant.

Changing Air-Conditioning System Hoses And Pipes

Reclaim the R-134a refrigerant from the vehicles air-conditioning system as described in the appropriate section.

Remove the problem hose or pipe.

Obtain an identical replacement hose or pipe.

Fit R-134a compatible O-rings.

Fit the new hose or pipe to the system

If necessary, fit a new R-134a service adaptor to the hose or pipe.

Recharge the air-conditioning system with R-134a refrigerant.

General

Any O-rings should be changes to R-134a compatible when a component is changed.

Whenever you break into an air-conditioning system, the receiver-drier and its associated O-rings must be changed for R-134a compatible type.

Air-Conditioning Unit Failure

If a component in the air-conditioning system fails for any reason, an identical replacement must be fitted in its place.

Receiver-Drier Failure

Always fit a new R-134a compatible receiver-drier as included in the retrofit kit of parts.

Oil Compatibility

As proven during exhaustive testing, it is possible to have more than the stated volume of oil in the air-conditioning system; i.e. it is permissible to have a Sanden compressor system with 135ml of Ester oil plus up to 50% residual mineral oil. However, always attempt to remove as much of the mineral oil as possible.

Parts Availability

O-rings, compressor shaft seals, receiver-drier bottles and retrofit charge port service adaptors will be available separately.

Safety and Correct Working Practices

General

Technical staff should be made aware of, and must comply with all health and safety requirements, whether they be legislated or following good workshop practice. Before commencing any repair or service procedure, the vehicle battery ground connection must be disconnected and appropriate action taken to protect the vehicle from dirt or damage. Work in a well ventilated, and clean area. Recovery and charge equipment must comply with, or exceed the standard detailed in General Specifications, of the Service Manual.

Use of Recovery and Recycling Unit in Workshop Handling Refrigerant

Eye protection must be worn at all times.

A suitable overall and gloves must be worn at all times when handling the refrigerants HFC R-134a and CFC R-12 to avoid contact with the skin. Should the refrigerant accidentally contact eyes or skin, wash the affected area with clean cool water immediately and seek medical advice without delay.

Avoid breathing-in refrigerant vapour; its inhalation may cause irritation to the respiratory system.

High pressure compressed air must never be used to flush-out a system. Under certain circumstances the combination of HFC R-134a, compressed air and a source of combustion, could result in an explosion.

Refrigerants HFC R-134a and CFC R-12 must never be allowed in contact, since they will form an inseparable mixture, disposable only by incineration.

Refrigerants must not be vented directly into the atmosphere use must always be made of Jaguar approved recovery equipment.

Refrigerant HFC R-134a and CFC R-12 being fully recyclable are capable of being 'cleaned' by their approved recovery equipment and re-used following removal from a system.

Leak tests may only be carried out with an electronic analyzer which is dedicated to HFC R-134a; never use an analyzer intended for CFC R-12 nor a naked flame type.

The quantity of refrigerant in a system must not be guessed. If in doubt, recover it in approved equipment and recharge the system with the specified charge weight.

The presence of any refrigerant must not be sought by venting a valve in the system.

Handling Lubrication Oil

Avoid breathing-in lubricant mist; its inhalation may cause irritation to the respiratory system.

The Ester oil used in the retrofit is miscible with the previously used mineral oil. It is also very hygroscopic and will rapidly absorb atmospheric moisture if left in unsealed containers. Never use Ester oil from a container that has not been kept sealed, nor expose them to the atmosphere other than during system charging or discharging. These are operations that should be carried-out expeditiously.

Even though Ester oil is miscible with previously used mineral based oils, it is recommended that as much mineral oil as possible be removed; on a Sanden compressor, it is permissible to have the required dose of 135ml plus up to 50% residual oil in the system.

DO NOT use Poly Alkylene Glycol (PAG) oils in the retrofit procedure. PAG oils are used in production built HFC-R134a systems, but are not miscible with the mineral oil used in the retrofit procedure.

Following a recovery cycle, the oil separated from the refrigerant must not be used again but must be disposed of safely.

System Maintenance

When a system is being depressurised, never vent the system to atmosphere but make proper use of Jaguar approved recovery equipment. Air-conditioning refrigerants are costly but may be recycled.

The Ester oil used in the retrofit is very hygroscopic and will rapidly absorb atmospheric moisture if left in unsealed containers. Never use these oils from a container that has not been kept sealed, nor expose them to the atmosphere other than during system charging or discharging. These are operations that should be carried-out expeditiously.

Diagnostic equipment for pressure, mass and volume should be calibrated regularly and certified by a third party organisation.

Plug pipes and units immediately after their disconnection and only unplug them immediately prior to connection. Do not leave the system open to the atmosphere.

Replacement parts supplied without transit plugs and seals should not be used, but returned to the supplier.

In the working area, all equipment, components and tools must be kept clean.

Use only the correct or recommended tools for the job and ensure that the manufacturer's specified torque values are applied.

Always adopt of a meticulous regime of closing disconnected pipes and components with suitable plugs immediately they occur, and removing them only at the last possible moment prior to connection. This will prevent unnecessary contamination and prevent the oil from absorbing moisture from the atmosphere.

JAGUAR XJ40 (Pre-90MY) AIR-CONDITIONING R-134a RETROFIT

Applicability

Jaguar XJ40 models in the VIN range: 507471 to 593883 (Pre-90MY).

Note: Vehicles covered by this instruction are fitted with a Sanden 510 compressor.

Pre-fitting Requirements

Open the driver side door and the bonnet.

Fit protective wing covers.

Reclaiming R-12 from the Air-conditioning System

Note: The reclamation of R-12 **must** be carried out in accordance with the instructions detailed in the operating manual provided with the charging station.

Position the R-12 air-conditioning charging station close to the vehicle.

Undo and remove the protective caps from the high and low pressure charging ports on the vehicle.

Position the R-12 air-conditioning charging station high and low pressure hoses to the vehicle.

Connect the low pressure hose (BLUE) to the vehicle low pressure charging port (1, Fig. 1).

Connect the high pressure hose (RED) to the vehicle high pressure charging port (2, Fig. 1).

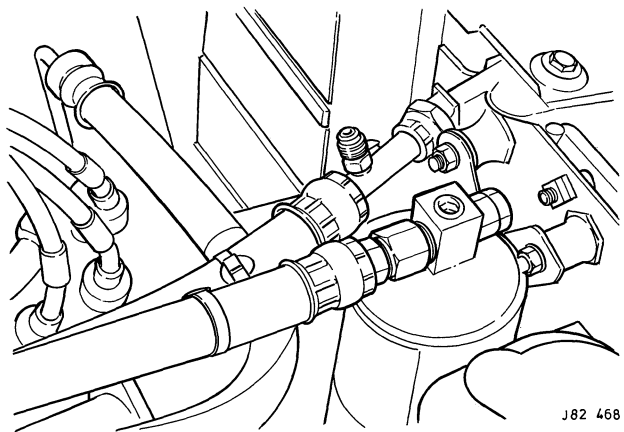
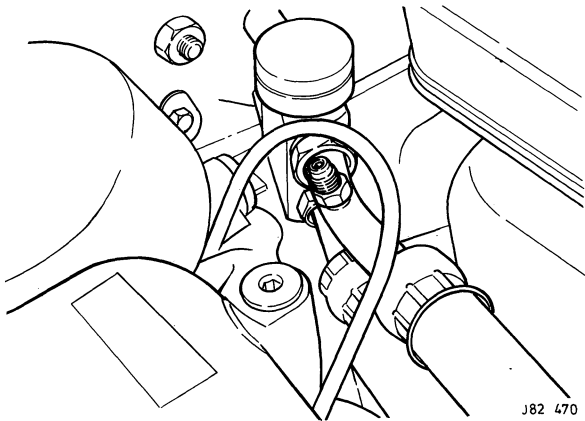

Fig. 1

From inside the vehicle, run the engine at idle speed for fifteen minutes with the air-conditioning controls set to manual, full cooling and high fan speed to establish the performance of the air-conditioning system. This operating condition also has the effect of collecting the majority of system mineral oil in the compressor.

Switch off the engine after fifteen minutes.

Disconnect the battery.

Switch the R-12 air-conditioning charging station to the recovery/reclaim mode.

Recover the R-12 refrigerant from the vehicle air-conditioning system.

Place suitable container under the charging station oil drain outlet and collect all oil recovered with the R-12 refrigerant during reclamation.

Isolate the R-12 air-conditioning charging station from the vehicle *in accordance with the instructions provided in the charging station operating manual.*

Removing the Air-conditioning System Compressor

Undo and remove the bolt securing the inlet and outlet port to the compressor.

Displace the expansion valve to compressor hose at the compressor and fit a suitable blanking plug to the open end of the hose.

Displace and remove the muffler from the compressor.

Remove the compressor port O-ring seals.

Fit a blanking plate to the rear of the compressor and secure in position with a bolt.

Place a suitable container beneath the muffler and reposition the muffler to allow oil to drain into the container.

Fit suitable blanking plugs to the muffler ports.

Cut and remove the tie straps securing the drive clutch coil harness.

Disconnect the drive clutch coil multi-plug connector.

Disconnect the compressor low pressure switch harness multi-plug.

Undo and remove the nut from the compressor pivot bolt (1, Fig. 2).

Raise the vehicle on ramps.

Slacken the trunnion nut and bolt (2, Fig. 2).

Undo and remove the nut and bolt securing the stabiling link (3, Fig. 2).

Slacken the nut and bolt securing the drive belt adjuster rod (4, Fig. 2).

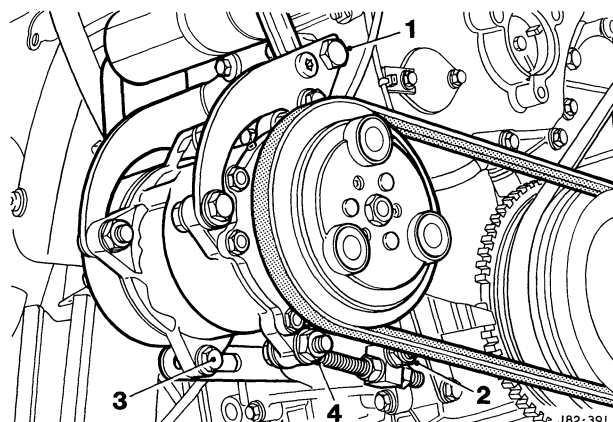

Fig. 2

Undo the adjuster nut.

Pivot the compressor to release the tension on the drive belt.

Remove the bolt securing the adjuster rod and remove the adjuster rod.

Remove the drive belt.

Pivot the compressor from the engine.

Displace and remove the pivot bolt assembly.

Displace and remove the compressor assembly and place on a clean workbench.

Draining the Compressor

Place a suitable container on the workbench.

Undo and remove the bolt securing the blanking plate to the compressor.

Displace and remove the blanking plate.

Undo and remove the compressor sump plug (1, Fig. 3).

Tip the compressor and drain the oil into the container.

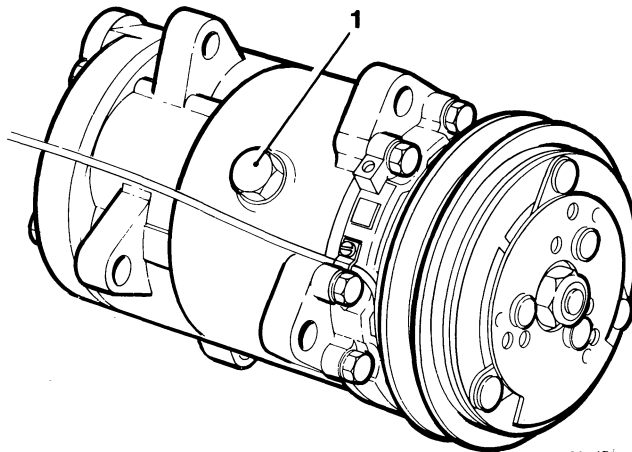

J82 472

Fig. 3

Compressor Front Seal Renewal

The front seal on this type of compressor must be removed because it is not compatible with R-134a refrigerant. The new, R-134a compatible, seal from the kit must be fitted in its place.

Secure the compressor in a suitable vice, taking care not to damage the compressor.

Fit the clutch drive service tool JD146-1 (1, Fig. 4) to the compressor and tighten the tool securing bolts.

Fit the service tool JD146-2 (Fig. 4) to the compressor.

Fit the tommy bar (Fig. 4).

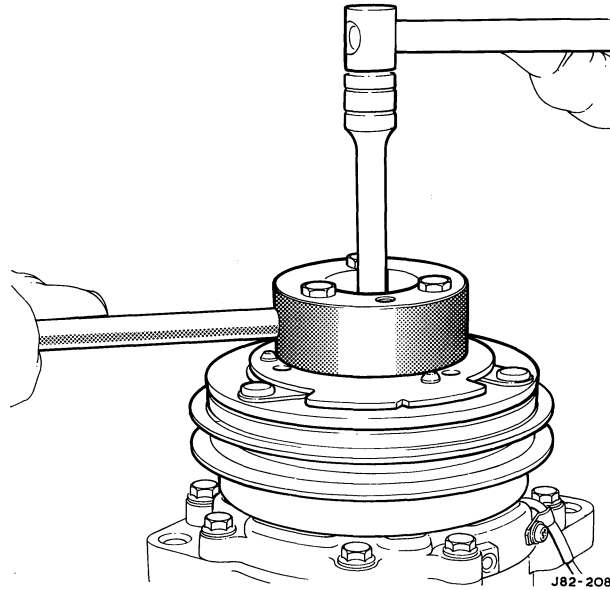

Fig. 4

Undo and remove the nut securing the clutch plate.

Fit the service tool JD146-3.

Tighten the tool centre bolt (Fig. 5) to remove the drive clutch front plate.

Undo and remove the bolts securing the service tool to the front plate.

Remove all service tools.

Place the clutch drive aside.

Displace and remove the Woodruff key from the compressor shaft.

Displace and remove the felt ring from the compressor.

Displace and remove the shims.

Displace and remove the seal seat retaining snap ring.

Fit tool JD147 (Fig. 6) to the seal seat.

Displace and remove the seal seat from the compressor.

Displace and remove the shaft seal O-ring.

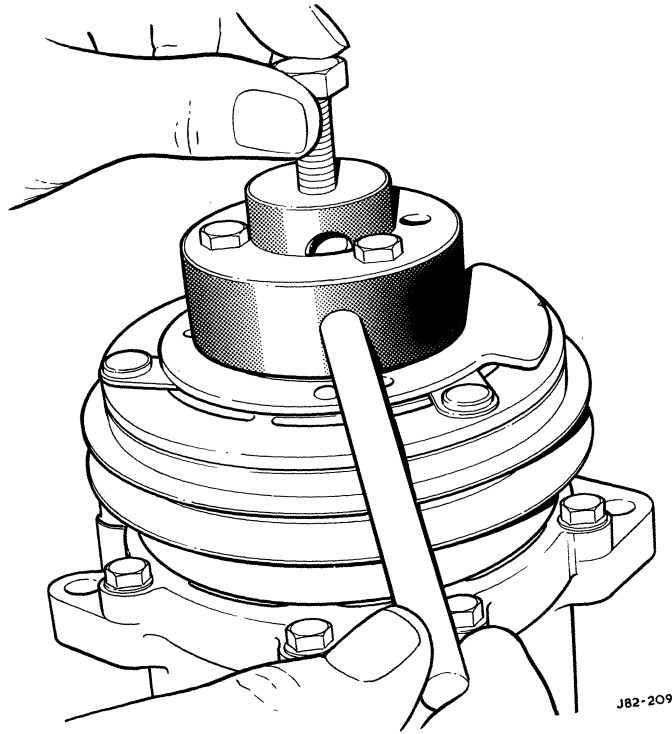

Fig. 5

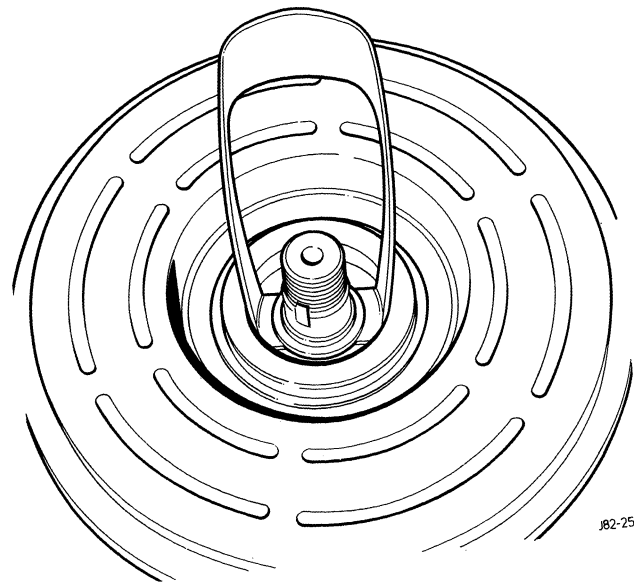

Fig. 6

Fit service tool JD150 (Fig. 7).

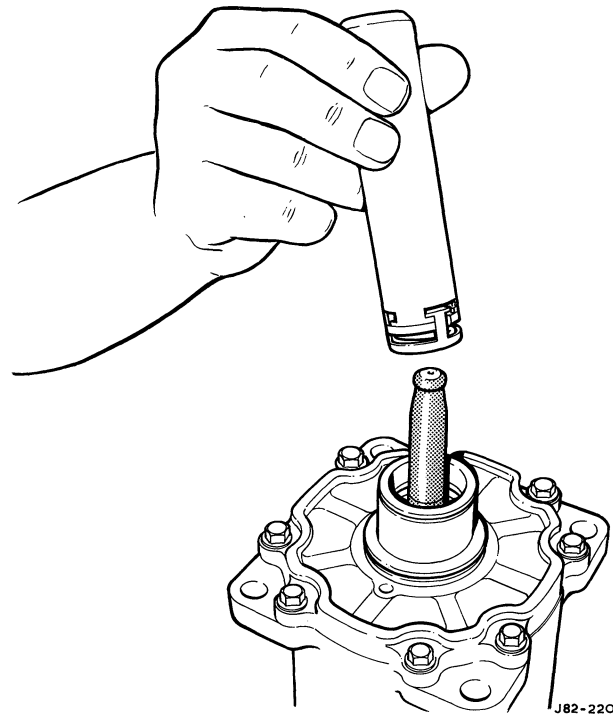

Fig. 7

Turn and remove the seal.

Remove the seal from service tool JD150.

Smear the new front seal seat and new O-ring with clean Ester oil.

Fit tool JD150 to the seal.

Fit the seal protector JD164 to the compressor shaft.

Fit and fully seat the seal to the compressor.

Fit and fully seat the shaft O-ring seal into the groove.

Disengage and remove the tool JD150 from the seal.

Using tool JD147, fit and fully seat the seal seat, then remove tool JD147.

Fit and fully seat the seal seat retaining snap ring.

Fit and fully seat the felt ring.

Fit and fully seat the shims to the compressor.

Fit and fully seat the Woodruff key.

Fit and align the compressor front plate to the keyway.

Fit and fully seat the clutch front plate to the compressor shaft using a suitable piece of tubing.

Remove the tubing.

Fit the clutch drive service tool JD146-1 to the clutch drive.

Fit and tighten the bolts to attach the clutch drive service tool to the clutch drive.

Fit the tommy bar to the clutch drive service tool JD146-1.

Fit and tighten the bolts to secure the clutch front plate.

Undo and remove the bolts securing the clutch drive service tool JD146-1 to the clutch drive.

Remove the tommy bar and the clutch drive service tool JD166-1 from the clutch drive.

Check the air gap (refer to the workshop manual for recommended air gap).

Remove the compressor from the vice.

Flushing the Compressor

Pour 100ml of Ester oil into a clean measuring vessel.

Pour the Ester oil from the measuring vessel into the compressor.

Manually work the oil around the compressor then drain and discard the oil from the compressor.

Recharging the Compressor

Pour 135ml of Ester oil into a clean measuring vessel.

Pour the Ester oil from the measuring vessel into the compressor.

Fit and fully tighten the compressor sump plug.

Fit and align the compressor blanking plate.

Fit and tighten the bolt to secure the blanking plate to the compressor.

Installing the Air-conditioning System Compressor

Fit and align the Ester-charged compressor to its mounting brackets.

Fit the pivot bolt assembly.

Connect the clutch coil harness multi-plug.

Connect the low pressure switch multi-plug connector to the low pressure switch at the rear of the compressor.

Fit the drive belt over the pulley.

Connect the drive belt to the pulley.

Fit the adjuster rod to the compressor.

Fit, but do not tighten, the adjuster rod clamp nut and bolt.

Position the compressor to the stabling link.

Fit, but do not tighten, the stabling link clamp nut and bolt.

Gradually tighten the adjuster nut to obtain the correct tension on the drive belt (refer to the workshop manual for the correct tension figure).

Tighten the adjusting rod locknut to preserve drive belt setting.

Fully tighten the nuts and bolts to secure the stabiling link and adjuster rod.

Lower the vehicle from the ramp.

Undo and remove the bolt securing the compressor port blanking plate to the compressor.

Displace and remove the blanking plate from the compressor.

Fit new O-rings to the compressor.

Displace and remove the blanking plugs from the compressor hoses.

Fit and fully seat the muffler to the compressor.

Fit and tighten the bolt to secure the muffler to the compressor.

Fit and fully tighten the nut to secure the pivot bolt.

Removing the Existing Receiver-Drier Bottle

Undo and remove the liquid line union nut at its connection on the receiver-drier bottle (Fig. 8).

Remove and discard the union nut O-ring seal.

Fit suitable blanking plugs to the end of the liquid line hose and to the open port in the receiver-drier bottle (1, Fig. 8).

At the receiver-drier bottle, undo and remove the union nut (3, Fig. 8) on the condenser-to-receiver-drier bottle pipe.

Undo and remove the nuts (2, Fig. 8) securing the receiver-drier bottle.

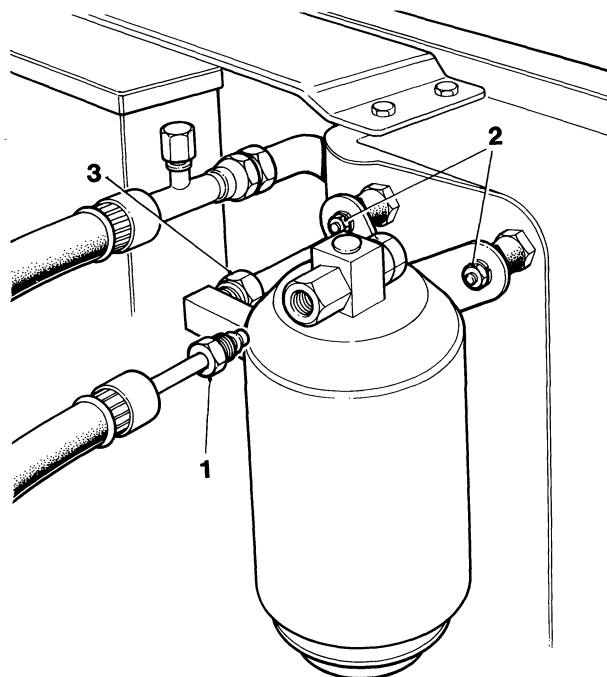

J82 173

Fig. 8

Displace and remove the receiver–drier from its mounting and disengage from the receiver–drier bottle–to–condenser pipe.

Remove and discard the O–ring seal from the union nut on the receiver–drier bottle–to–condenser pipe.

Fit suitable blanking plugs to the receiver–drier bottle and to the receiver–drier bottle–to–condenser pipe.

Fitting a New R–134a Compatible Receiver–Drier Bottle

Fit a new O–ring seal to the union nut on the receiver–drier bottle–to–condenser pipe.

Remove the blanking plugs from the new receiver–drier–bottle.

Fit and align a new receiver–drier bottle to its mounting bobbin and engage the receiver–drier bottle–to–condenser pipe.

Fit and fully tighten the nuts to secure the receiver–drier bottle.

Fit and fully tighten the union nut on the receiver–drier bottle–to–condenser pipe.

Remove the blanking plugs from the liquid line and the port in the receiver–drier bottle.

Fit a new O–ring seal to the union nut on the liquid line.

Connect the liquid line union nut to the receiver–drier bottle and fully tighten to secure.

Fitting R–134a Adaptors to the R–12 Fittings

The charge port service adaptor threads are coated with thread–locking fluid. Ensure that the threads of the existing R–12 charging valves are cleaned before fitting the new adaptors.

Fit and tighten a straight R–134a refrigerant high pressure adaptor (RED) (Fig. 9) to the R–12 high pressure connector on the discharge hose.

Fit and tighten a straight R–134a refrigerant low pressure adaptor (BLUE) (Fig. 9) to the R–12 low pressure connector on the suction hose.

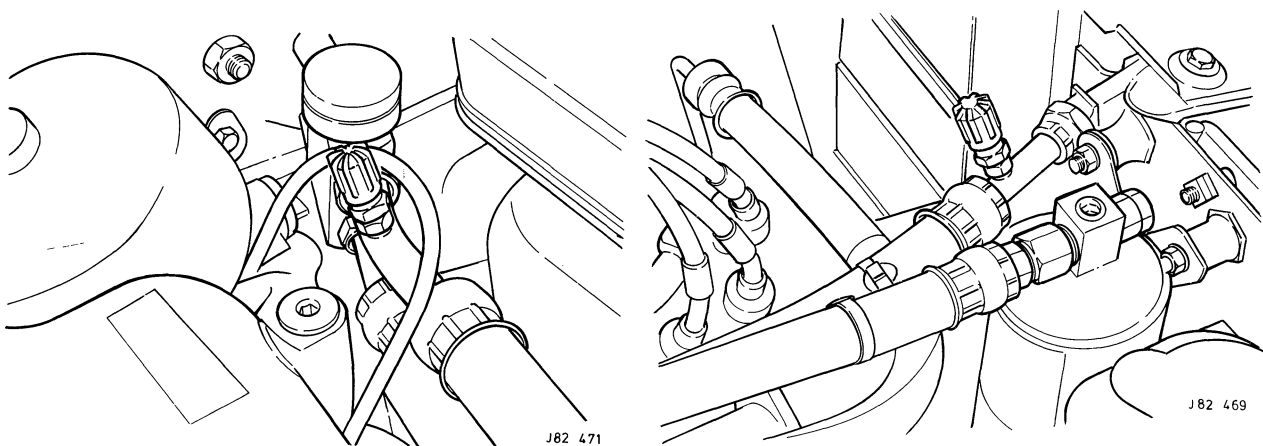

Fig. 9

Charging the Vehicle Air-conditioning System with R-134a Refrigerant

Note: Charging of the air-conditioning charging station and the vehicles air-conditioning system **must** be carried out in accordance with the instructions detailed in the operating manual provided with the charging station.

Position the R-134a air-conditioning charging station close to the vehicle and R-134a gas supply cylinder.

Charge the R-134a air-conditioning charging station with 1150 grammes of R-134a refrigerant from a gas supply cylinder.

Disconnect the air-conditioning charging station from the gas supply cylinder.

Undo and remove the protective caps from the high and low pressure charging ports on the vehicle.

Position the R-134a air-conditioning charging station high and low pressure hoses to the vehicle.

Connect the high pressure hose (RED) to the vehicle high pressure charging port (Fig. 9).

Connect the low pressure hose (BLUE) to the vehicle low pressure charging port (Fig. 9).

Evacuate the system in accordance with the charging station procedures.

Switch the R143a air-conditioning charging station to the charging mode.

Charge the vehicle air-conditioning system with 1150 grammes of R-134a refrigerant.

Disconnect the charging station high and low pressure hoses from the charging port adaptors on the vehicle.

Fit protective caps to the low and high pressure adaptors on the vehicle; RED cap for the high pressure adaptor and the BLUE cap for the low pressure adaptor.

Retrofit Warning Labels

Using a suitable oil-resistant marker, fill in all retrofit details on the retrofit label supplied, including the name of the installing Dealer.

Tear off the appropriate language section or sections.

Remove the backing from the self-adhesive label and affix to a prominent position on the inner wing, covering the existing R-12 information label where possible.

Remove, destroy or permanently deface all original labels referring to R-12 refrigerant.

Post-fitting Checks

Using a dedicated HFC R-134a electronic analyser, check for non-visible leaks around the system; gross leakage will be evident by the escape of oil.

Reconnect the battery.

From inside the vehicle, run the engine at idle speed for fifteen minutes with the air-conditioning controls set to manual, full cooling and high fan speed to establish the performance of the air-conditioning system.

Reset the vehicle radio security code and the time clock.

Remove the protective wing covers.

Close the driver side door and the bonnet.

JAGUAR XJ40 (Post-90MY) AIR-CONDITIONING R-134a RETROFIT

Applicability

Jaguar XJ40 models in the VIN range: 593884 to 667578 (Post-90MY).

Note: Vehicles covered by this instruction are fitted with a Sanden 709 compressor.

Pre-fitting Requirements

Open the driver side door and the bonnet.

Fit protective wing covers.

Reclaiming R-12 from the Air-conditioning System

Note: The reclamation of R-12 **must** be carried out in accordance with the instructions detailed in the operating manual provided with the charging station.

Position the R-12 air-conditioning charging station close to the vehicle.

Undo and remove the protective caps from the high and low pressure charging ports on the vehicle.

Position the R-12 air-conditioning charging station high and low pressure hoses to the vehicle.

Connect the low pressure hose (BLUE) to the vehicle low pressure charging port (1, Fig. 1).

Connect the high pressure hose (RED) to the vehicle high pressure charging port (2, Fig. 1).

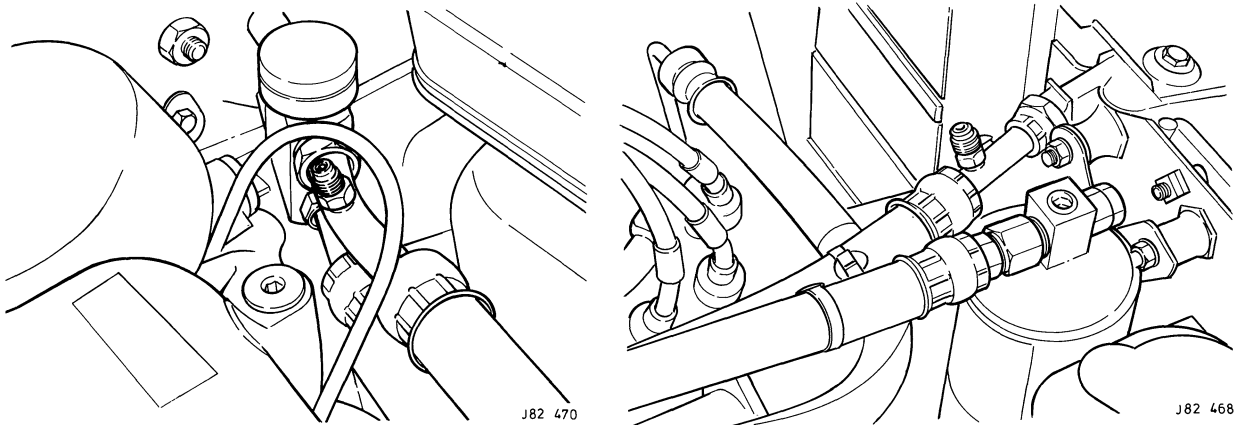

Fig. 1

From inside the vehicle, run the engine at idle speed for fifteen minutes with the air-conditioning controls set to manual, full cooling and high fan speed to establish the performance of the air-conditioning system. This operating condition also has the effect of collecting the majority of system mineral oil in the compressor.

Switch off the engine after fifteen minutes.

Disconnect the battery.

Switch the R-12 air-conditioning charging station to the recovery/reclaim mode.

Recover the R-12 refrigerant from the vehicle air-conditioning system.

Place suitable container under the charging station oil drain outlet and collect all oil recovered with the R-12 refrigerant during reclamation.

Isolate the R-12 air-conditioning charging station from the vehicle *in accordance with the instructions provided in the charging station operating manual.*

Removing the Air-conditioning System Compressor

Undo and remove the bolt securing the muffler to the compressor front mounting bracket.

Undo and remove the bolt securing the muffler to the compressor inlet and outlet ports.

Displace and reposition the muffler assembly.

Remove the compressor port O-ring seals.

Fit a blanking plate to the rear of the compressor and secure in position with a bolt.

Fit suitable blanking plugs to the muffler ports.

Fit a blanking plate to the rear of the compressor.

Fit and tighten a dummy bolt to secure the blanking plate to the compressor.

Cut and remove the ratchet straps securing the drive clutch coil harness.

Disconnect the drive clutch coil multi-plug connector.

Undo and remove the nut from the compressor pivot bolt (1, Fig. 2).

Raise the vehicle on ramps.

Slacken the trunnion nut and bolt (2, Fig. 2).

Undo and remove the nut and bolt securing the stabiling link (3, Fig. 2).

Slacken the nut and bolt securing the drive belt adjuster rod (4, Fig. 2).

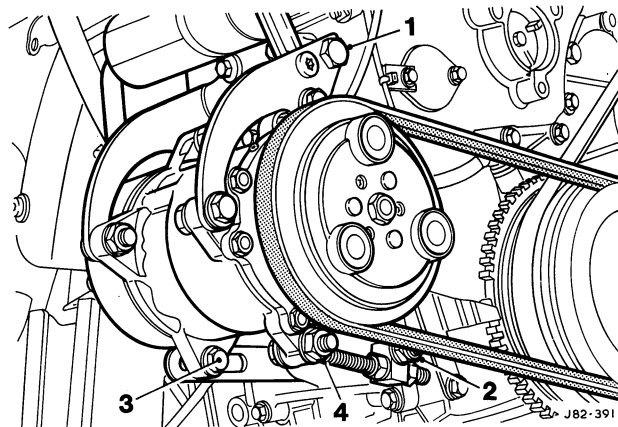

Fig. 2

Undo the adjuster nut.

Pivot the compressor to release the tension on the drive belt.

Remove the bolt securing the adjuster rod and remove the adjuster rod.

Remove the drive belt.

Pivot the compressor from the engine.

Displace and remove the pivot bolt assembly.

Displace and remove the compressor assembly and place on a clean workbench.

Draining the Compressor

Place a suitable container on the workbench.

Undo and remove the bolt securing the blanking plate to the compressor.

Displace and remove the blanking plate.

Undo and remove the compressor sump plug (1, Fig. 3).

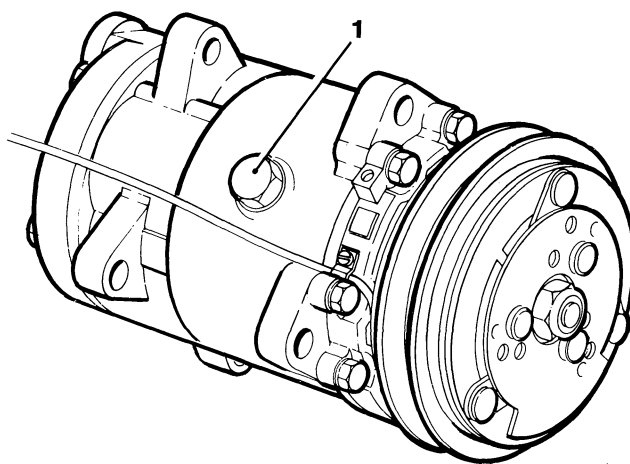

J82 472

Fig. 3

Tip the compressor and drain the oil into the container.

Compressor Front Seal Renewal

The front seal on this type of compressor must be removed because it is not compatible with R-134a refrigerant. The new, R-134a compatible, seal from the kit must be fitted in its place.

Secure the compressor in a suitable vice, clamping on the body lugs.

Fit the clutch drive service tool JD166-1 (Fig. 4) to the compressor and tighten the tool securing bolts.

Fit the tommy bar JD166-2 (Fig. 4) to the clutch drive service tool JD166-1.

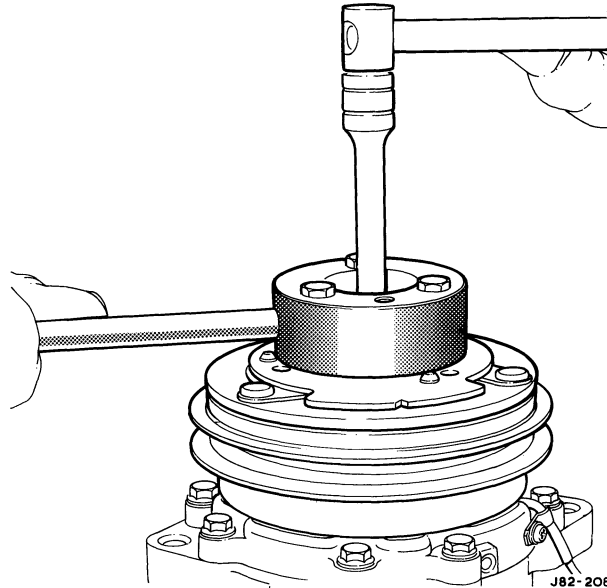

Fig. 4

Undo and remove the nut securing the drive clutch.

Fit the service tool JD166-3 to the clutch drive service tool JD166-1.

Reposition the tommy bar JD166-2 (1, Fig. 5) to engage the tool JD166-3.

Tighten the tool centre bolt (2, Fig. 5) to remove the drive clutch.

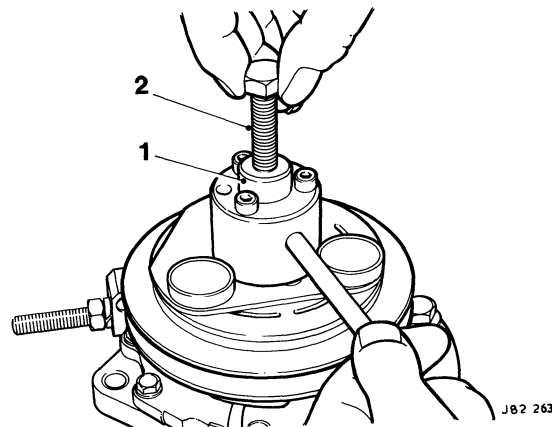

Fig. 5

Remove clutch service tool and the drive clutch from the compressor.

Return the tool centre bolt to the original position for future use.

Reposition the tommy bar JD166-2 to release tool JD166-3.

Remove tool JD166-3 from the clutch drive service tool JD166-1.

Undo and remove the bolts securing the clutch drive service tool JD166-1 to the drive clutch.

Remove the clutch drive service tool and place the clutch drive aside.

Displace and remove the clutch air gap adjustment shims from the compressor shaft.

Displace and remove the Woodruff key from the compressor shaft.

Displace and remove the felt ring from the compressor.

Displace and remove the seal seat retaining snap ring.

Fit tool JD167 (1, Fig. 6) to the seal seat (2, Fig. 6), engaging the tangs of the tool in the groove in the seal seat.

Displace and remove the seal seat from the compressor.

Remove tool JD167 from the seal seat.

Displace and remove the shaft seal O-ring.

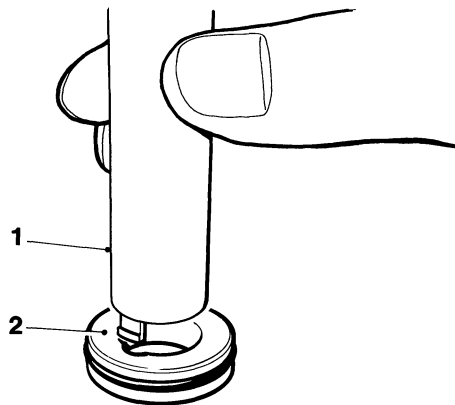

J82 282

Fig. 6

Fit service tool JD168 (1, Fig. 7) to the front seal.

Engage the tangs of tool JD168 with those of the seal and, using a twisting action, remove the seal from the compressor.

Remove the seal from tool JD168.

Fit the seal protector JD164 (2, Fig. 7) to the compressor shaft.

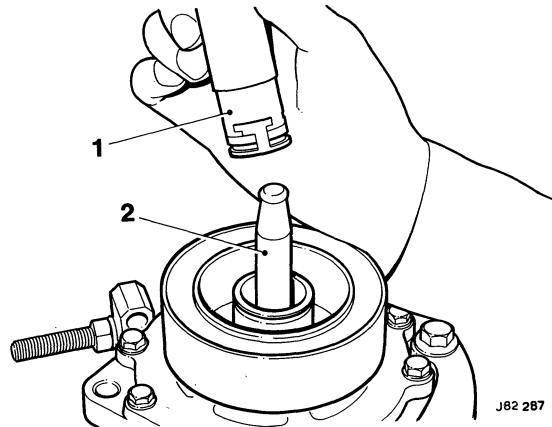

Fig. 7

Smear the new front seal seat and new O-ring with clean Ester oil.

Fit tool JD168 to the new front seal.

Using a twisting action, fit and fully seat the front seal to the compressor.

Disengage and remove the tool JD168 from the front seal.

Fit and fully seat the shaft O-ring seal into the groove.

Using tool JD167, fit and fully seat the seal seat, engaging the tangs of the tool with those in the seal seat.

Fit and fully seat the seal seat retaining snap ring.

Fit and fully seat the felt ring.

Fit and fully seat the Woodruff key.

Fit and fully seat the clutch air gap adjustment shims to the compressor.

Fit and align the drive clutch to the keyway.

Fit and fully seat the drive clutch to the compressor shaft using a suitable piece of tubing.

Remove the tubing.

Fit the clutch drive service tool JD166-1 to the clutch drive.

Fit and tighten the bolts to attach the clutch drive service tool to the clutch drive.

Fit the tommy bar JD166-2 to the clutch drive service tool JD166-1.

Fit and tighten the nut to secure the clutch drive.

Undo and remove the bolts securing the clutch drive service tool JD146-1 to the clutch drive.

Remove the tommy bar JD166-2 and the clutch drive service tool JD166-1 from the clutch drive.

Check the air gap (refer to the workshop manual for recommended air gap).

Remove the compressor from the vice.

Flushing the Compressor

Pour 100ml of Ester oil into a clean measuring vessel.

Pour the Ester oil from the measuring vessel into the compressor.

Manually work the oil around the compressor then drain and discard the oil from the compressor.

Recharging the Compressor

Pour 135ml of Ester oil into a clean measuring vessel.

Pour the Ester oil from the measuring vessel into the compressor.

Fit and fully tighten the compressor sump plug.

Fit and align the compressor blanking plate.

Fit and tighten the bolt to secure the blanking plate to the compressor.

Installing the Air-conditioning System Compressor

Fit and align the Ester-charged compressor to its mounting brackets.

Fit the pivot bolt assembly.

Connect the clutch coil harness multi-plug.

Fit the drive belt over the pulley.

Connect the drive belt to the pulley.

Fit the adjuster rod to the compressor.

Fit, but do not tighten, the adjuster rod clamp nut and bolt.

Position the compressor to the stabling link.

Fit, but do not tighten, the stabling link clamp nut and bolt.

Gradually tighten the adjuster nut to obtain the correct tension on the drive belt (refer to the workshop manual for the correct tension figure).

Tighten the adjusting rod locknut to preserve drive belt setting.

Fully tighten the nuts and bolts to secure the stabling link and adjuster rod.

Lower the vehicle from the ramp.

Undo and remove the bolt securing the compressor port blanking plate to the compressor.

Displace and remove the blanking plate from the compressor.

Fit new O-rings to the compressor.

Displace and remove the blanking plugs from the compressor hoses.

Fit and fully seat the muffler to the compressor.

Fit and tighten the bolt to secure the muffler to the compressor.

Fit and fully tighten the nut to secure the pivot bolt.

Removing the Existing Receiver-Drier Bottle

At the receiver-drier bottle, undo the liquid line union nut (1, Fig. 8).

Remove the hose from the receiver-drier bottle.

Remove and discard the union nut O-ring seal.

Fit suitable blanking plugs to the end of the hose and to the open port in the receiver-drier bottle.

At the receiver-drier bottle, undo and remove the union nut (3, Fig. 8) on the condenser-to-receiver-drier bottle pipe.

Undo and remove the nuts (2, Fig. 8) securing the receiver-drier bottle.

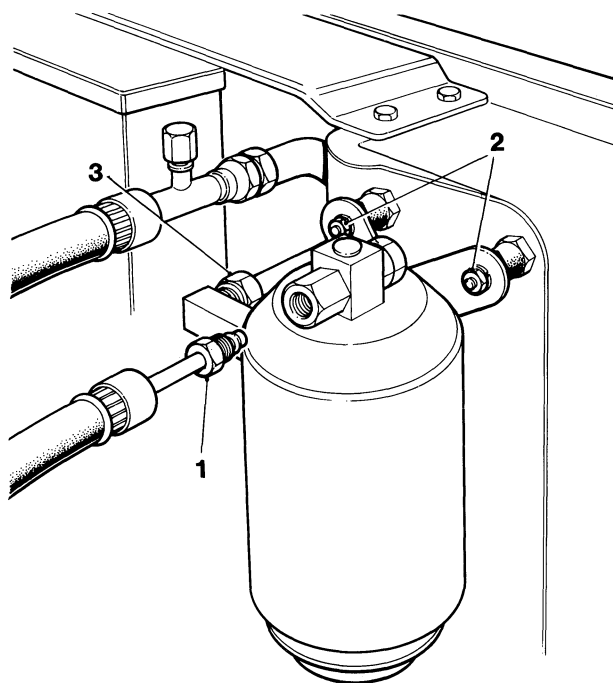

J82 173

Fig. 8

Displace and remove the receiver-drier from its mounting and disengage from the receiver-drier bottle-to-condenser pipe.

Remove and discard the O-ring seal from the union nut on the receiver-drier bottle-to-condenser pipe.

Fit suitable blanking plugs to the receiver-drier bottle and to the receiver-drier bottle-to-condenser pipe.

Fitting a New R-134a Compatible Receiver-Drier Bottle

Fit a new O-ring seal to the union nut on the receiver-drier bottle-to-condenser pipe.

Remove the blanking plugs from the new receiver-drier bottle.

Fit and align a new receiver-drier bottle to its mounting bobbin and engage the receiver-drier bottle-to-condenser pipe.

Fit and fully tighten the nuts to secure the receiver-drier bottle.

Fit and fully tighten the union nut on the receiver-drier bottle-to-condenser pipe.

Remove the blanking plugs from the liquid and the port in the receiver-drier bottle.

Fit a new O-ring seal to the union nut on the liquid line.

Connect the liquid line union nut to the receiver-drier bottle and fully tighten to secure.

Fitting R-134a Adaptors to the R-12 Fittings

The charge port service adaptor threads are coated with thread-locking fluid. Ensure that the threads of the existing R-12 charging valves are cleaned before fitting the new adaptors.

Fit and tighten a straight R-134a refrigerant high pressure adaptor (RED) (Fig. 9) to the R-12 high pressure connector on the discharge hose.

Note: At 91MY, undo and remove the Schrader valve from the R-12 high pressure connector on the discharge hose and fit an R-134a refrigerant high pressure elbow adaptor to the R-12 connector. The Schrader valve must be removed to enable the R-134a elbow connector to function properly.

Fit and tighten a straight R-134a refrigerant low pressure adaptor (BLUE) (Fig. 9) to the R-12 low pressure connector on the suction hose.

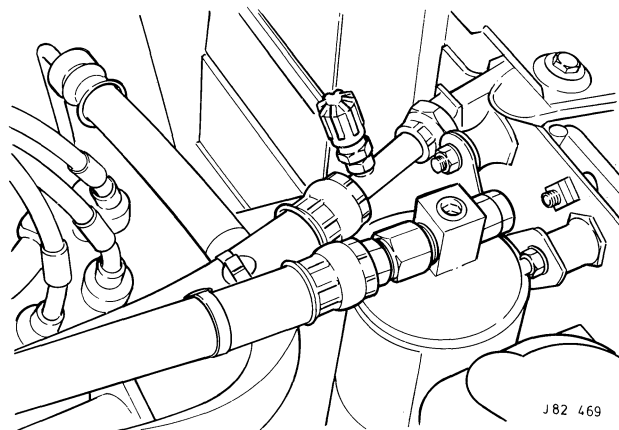
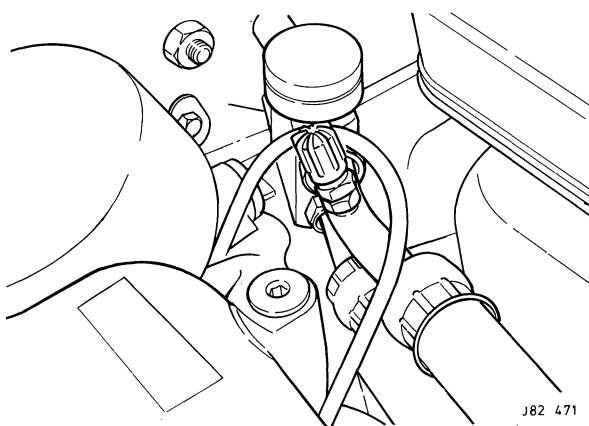

Fig. 9

Charging the Vehicle Air-conditioning System with R-134a Refrigerant

Note: Charging of the air-conditioning charging station and the vehicles air-conditioning system **must** be carried out in accordance with the instructions detailed in the operating manual provided with the charging station.

Position the R-134a air-conditioning charging station close to the vehicle and R-134a gas supply cylinder.

Charge the R-134a air-conditioning charging station with 1150 grammes of R-134a refrigerant from a gas supply cylinder.

Disconnect the air-conditioning charging station from the gas supply cylinder.

Undo and remove the protective caps from the high and low pressure charging ports on the vehicle.

Position the R-134a air-conditioning charging station high and low pressure hoses to the vehicle.

Connect the high pressure hose (RED) to the vehicle high pressure charging port (Fig. 9).

Connect the low pressure hose (BLUE) to the vehicle low pressure charging port (Fig. 9).

Evacuate the system in accordance with the charging station procedures.

Switch the R143a air-conditioning charging station to the charging mode.

Charge the vehicle air-conditioning system with 1150 grammes of R-134a refrigerant.

Disconnect the charging station high and low pressure hoses from the charging port adaptors on the vehicle.

Fit protective caps to the low and high pressure adaptors on the vehicle; RED cap for the high pressure adaptor and the BLUE cap for the low pressure adaptor.

Retrofit Warning Labels

Using a suitable oil-resistant marker, fill in all retrofit details on the retrofit label supplied, including the name of the installing Dealer.

Tear off the appropriate language section or sections.

Remove the backing from the self-adhesive label and affix to a prominent position on the inner wing, covering the existing R-12 information label where possible.

Remove, destroy or permanently deface all original labels referring to R-12 refrigerant.

Post-fitting Checks

Using a dedicated HFC R-134a electronic analyser, check for non-visible leaks around the system; gross leakage will be evident by the escape of oil.

Reconnect the battery.

From inside the vehicle, run the engine at idle speed for fifteen minutes with the air-conditioning controls set to manual, full cooling and high fan speed to establish the performance of the air-conditioning system.

Reset the vehicle radio security code and the time clock.

Remove the protective wing covers.

Close the driver side door and the bonnet.

JAGUAR XJS 5.3 LITRE V12 AIR-CONDITIONING R-134a RETROFIT

Applicability

Jaguar 5.3 litre XJS models in the VIN range: 100001 to 188104.

Note: Vehicles covered by this instruction are fitted with a Harrison compressor.

Pre-fitting Requirements

Open the driver side door and the bonnet.

Fit protective wing covers.

Reclaiming R-12 from the Air-conditioning System

Note: The reclamation of R-12 **must** be carried out in accordance with the instructions detailed in the operating manual provided with the charging station.

Position the R-12 air-conditioning charging station close to the vehicle.

Undo and remove the protective caps from the high and low pressure charging ports on the vehicle.

Position the R-12 air-conditioning charging station high and low pressure hoses to the vehicle.

Connect the low pressure hose (BLUE) to the vehicle low pressure charging port (1, Fig. 1).

Connect the high pressure hose (RED) to the vehicle high pressure charging port (2, Fig. 1).

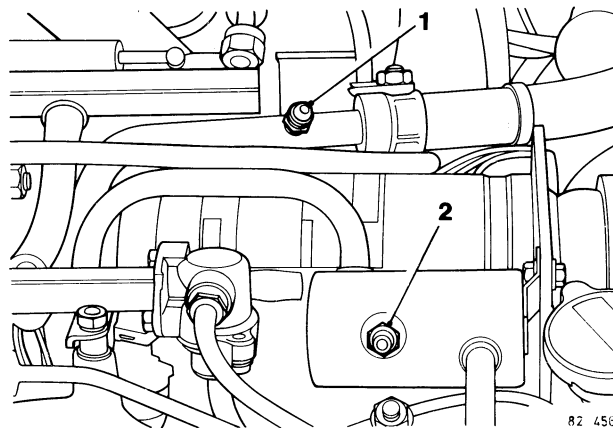

Fig. 1

From inside the vehicle, run the engine at idle speed for fifteen minutes with the air-conditioning controls set to manual, full cooling and high fan speed to establish the performance of the air-conditioning system. This operating condition also has the effect of collecting the majority of system mineral oil in the compressor.

Switch off the engine after fifteen minutes.

Disconnect the battery.

Switch the R-12 air-conditioning charging station to the recovery/reclaim mode.

Recover the R-12 refrigerant from the vehicle air-conditioning system.

Place suitable container under the charging station oil drain outlet and collect all oil recovered with the R-12 refrigerant during reclamation.

Isolate the R-12 air-conditioning charging station from the vehicle *in accordance with the instructions provided in the charging station operating manual.*

Removing the Air-conditioning System Compressor

Slacken the bolt securing the drive belt tensioning idler pulley carrier (1, Fig. 2) to the mounting bracket.

Slacken the bolt securing the adjusting rod to the idler pulley carrier (4, Fig. 2).

Undo the adjusting rod locknut (3, Fig. 2).

Note: Pivot the pulley in towards the engine to release tension on the drive belt.

Displace and reposition the compressor drive belt.

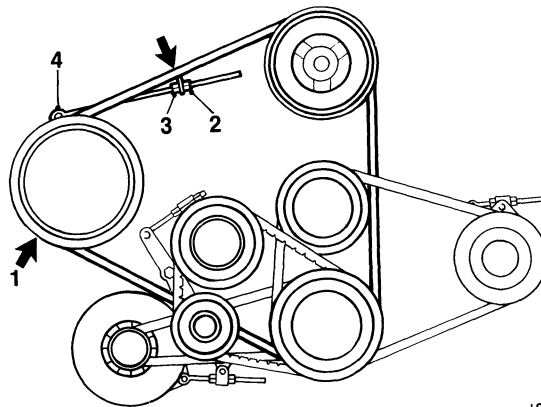

J82-349

Fig. 2

Disconnect the compressor low pressure switch harness multi-plug (1, Fig. 3).

Disconnect the drive clutch coil multi-plug connector (2, Fig. 3)

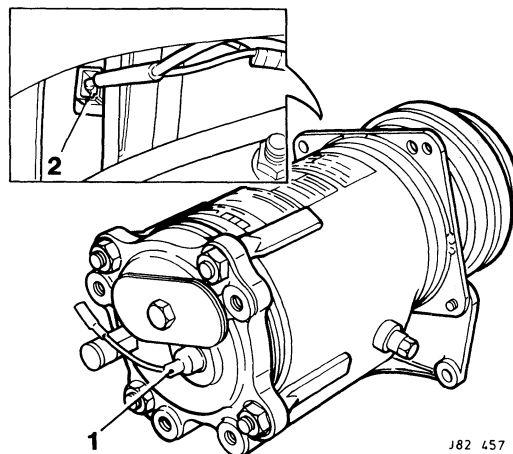

J82 457

Fig. 3

Undo and remove the bolt securing the compressor muffler to the compressor forward mounting (1, Fig. 4).

Undo and remove the bolts securing the cruise control bellows mounting bracket.

Displace and reposition the cruise control bellows assembly.

Undo and remove the bolt (2, Fig. 4) securing the compressor hoses together with the cruise control bellows mounting bracket.

Displace the muffler and suction hose from the rear of the compressor.

Remove and discard the compressor O-ring seals.

Fit suitable blanking plugs to the open hoses to prevent the ingress of foreign material.

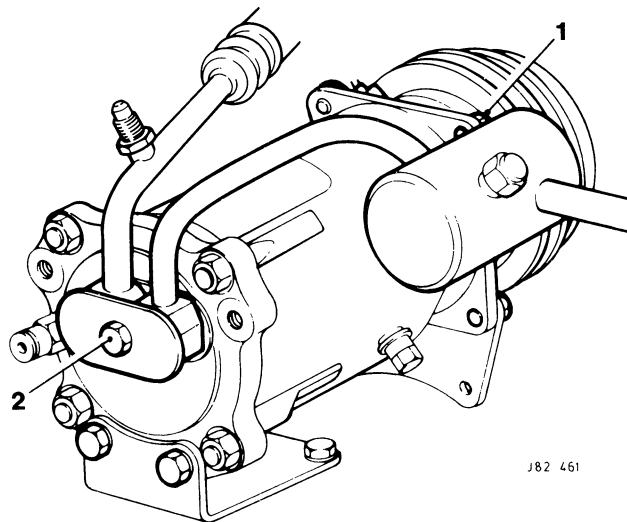

Fig. 4

Fit a blanking plate (1, Fig. 5) to the compressor.

Fit and tighten the bolt (2, Fig. 5) to secure the blanking plate to the compressor.

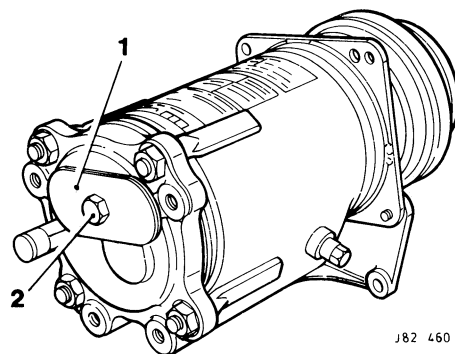
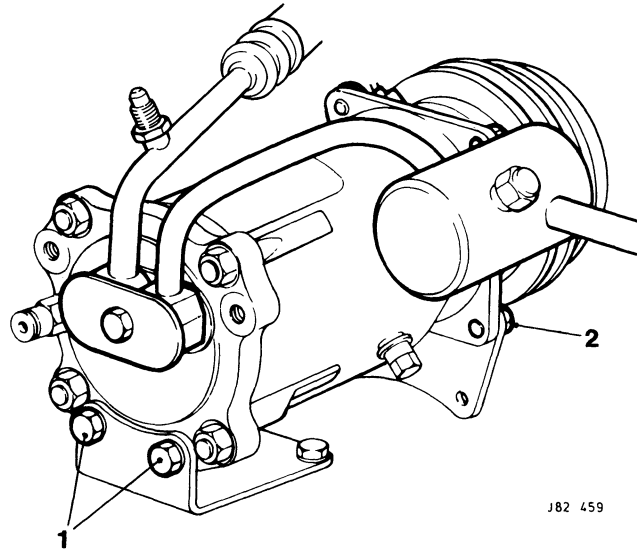

Fig. 5

Undo and remove the bolts (1, Fig. 6) securing the compressor to the rear mounting bracket.
Undo and remove the bolts (2, Fig. 6) securing the compressor to the front mounting bracket.
Displace and remove the compressor assembly and place on a clean workbench.



J82 459

Fig. 6

Draining, Flushing and Recharging the Compressor

Place a suitable measuring container on the workbench.

Undo and remove the bolt securing the blanking plate to the compressor.

Displace and remove the blanking plate.

Undo and remove the compressor sump plug (1, Fig. 7).

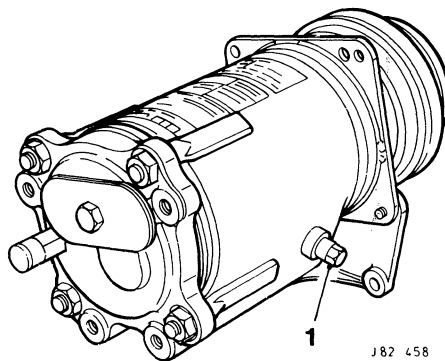

J82 458

Fig. 7

Tip the compressor and drain compressor oil into a suitable container.

Undo the discharge hose muffler union nut.

Disconnect the muffler from the discharge hose.

Remove and discard the hose O-ring seal.

Fit a suitable blanking plug to the discharge hose.

Drain the oil from the muffler into a suitable container.

Fit suitable blanking plugs to the open ports in the muffler to prevent the ingress of foreign material.

Pour 100ml of Ester oil in a clean measuring vessel.

Pour the Ester oil from the measuring vessel into the compressor.

Manually work the oil around the compressor then drain and discard the oil from the compressor.

Recharging the Compressor

Pour 284ml of Ester oil into a clean measuring vessel.

Pour the Ester oil from the measuring vessel into the compressor.

Fit and fully tighten the compressor sump plug.

Installing the Air-conditioning System Compressor

Fit and align the compressor blanking plate.

Fit and tighten the bolt to secure the blanking plate to the compressor.

Fit and align the Ester-charged compressor to its mounting brackets.

Fit and fully tighten the bolts to secure the compressor to the front mounting bracket.

Fit and fully tighten the nuts to secure the compressor to the rear mounting bracket.

Connect the low pressure switch multi-plug connector to the low pressure switch at the rear of the compressor.

Undo and remove the bolt securing the compressor port blanking plate to the compressor.

Displace and remove the blanking plate from the compressor.

Fit new O-rings to the compressor.

Displace and remove the blanking plugs from the compressor muffler.

Fit and fully seat the compressor suction hose to the compressor.

Fit and align the muffler to the compressor.

Fit and tighten the nut and bolt to secure the muffler to the compressor forward mounting.

Fit and align the cruise control bellows mounting bracket assembly to the compressor discharge and suction hoses.

Fit and tighten the bolts to secure the cruise control mounting bracket.

Fit and tighten the compressor hose and muffler securing bolt

Reposition the cruise control bellows.

Tighten the bolt to secure the cruise control bellows to its mounting bracket.

Connect the clutch coil harness multi-plug.

Remove the plug from the discharge hose.

Fit a new O-ring seal to the discharge hose.

Connect the hose to the muffler.

Tighten the union nut to secure the hose to the muffler.

Fit and align the compressor drive belt to the compressor.

Tighten the adjusting rod adjustment locknut (3, Fig. 2) to achieve the correct tension on the compressor drive belt. Refer to the workshop manual for the correct tension figure.

Tighten the adjusting rod locknut (2, Fig. 2) to preserve drive belt setting.

Tighten the bolt to secure the adjusting rod to the idler pulley carrier.

Tighten the bolt to secure the idler pulley carrier to the mounting bracket pivot.

Removing the Existing Receiver-Drier Bottle

Undo the liquid line union nut at its connection on the receiver-drier bottle Fig. 8.

Undo the condenser pipe union nut at its connection on the receiver-drier bottle.

Undo and remove the nuts securing the receiver-drier bottle top rail mounting brackets to the top rail.

Displace the bleed pipe securing clips from their studs.

Undo and remove the clamping nuts and bolts securing the receiver-drier into its top rail mounting brackets.

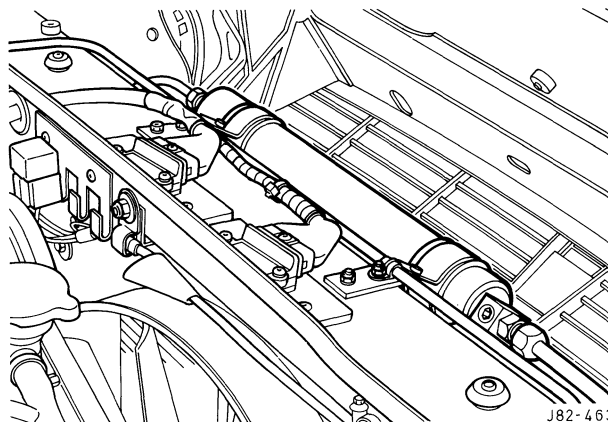

Fig. 8

Displace and reposition the receiver–drier bottle top rail mounting brackets from the top rail.

Disconnect the liquid line.

Remove and discard the liquid line O–ring seal.

Disconnect the receiver–drier bottle from the condenser pipe.

Remove and discard the receiver–drier bottle pipe O–ring seal.

Displace and remove the receiver–drier bottle.

Fit suitable blanking plugs to the receiver–drier bottle and pipes.

Fitting a New R–134a Compatible Receiver–Drier Bottle

Place a new receiver–drier bottle on the workbench.

Remove the backing paper from the receiver–drier bottle mounting rubbers.

Fit and align the mounting rubbers to the new receiver–drier bottle.

Fit and align the top rail mounting brackets to the receiver–drier, ensuring that the sight glass is facing upwards.

Undo and remove the receiver–drier bottle protective caps.

Remove the blanking plugs from the pipes.

Fit new O–rings seals to the pipes.

Place the receiver–drier bottle to the vehicle.

Connect pipes to the receiver–drier bottle.

Fit but do not tighten the pipe union nuts.

Position the receiver–drier bottle mounting brackets to the top rail.

Position the bleed pipe mounting clips to the top rail studs.

Fit and tighten the receiver–drier bottle mounting bracket securing nuts.

Fit and tighten the mounting bracket clamping nuts and bolts.

Fully tighten union nuts to secure the pipes to the receiver–drier bottle.

Fitting R-134a Adaptors to the R-12 Fittings

The charge port service adaptor threads are coated with thread-locking fluid. Ensure that the threads of the existing R-12 charging valves are cleaned before fitting the new adaptors.

Fit and tighten an R-134a refrigerant high pressure adaptor (RED) (Fig. 9) to the R-12 high pressure connector on the discharge hose.

Fit and tighten an R-134a refrigerant low pressure adaptor (BLUE) (Fig. 9) to the R-12 low pressure connector on the suction hose.

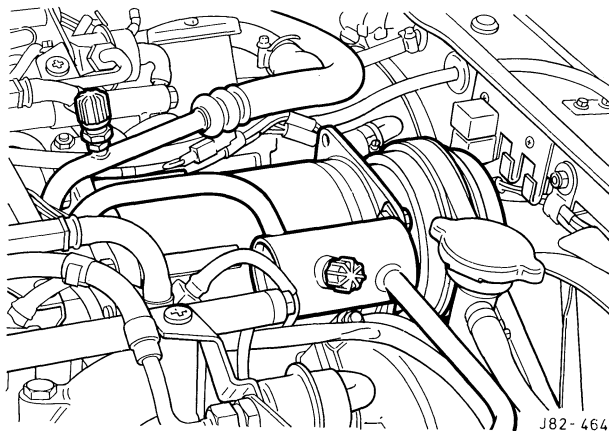

Fig. 9

Charging the Vehicle Air-conditioning System with R-134a Refrigerant

Note: Charging of the air-conditioning charging station and the vehicles air-conditioning system **must** be carried out in accordance with the instructions detailed in the operating manual provided with the charging station.

Position the R-134a air-conditioning charging station close to the vehicle and R-134a gas supply cylinder.

Charge the R-134a air-conditioning charging station with 1150 grammes of R-134a refrigerant from a gas supply cylinder.

Disconnect the air-conditioning charging station from the gas supply cylinder.

Undo and remove the protective caps from the high and low pressure charging ports on the vehicle.

Position the R-134a air-conditioning charging station high and low pressure hoses to the vehicle.

Connect the high pressure hose (RED) to the vehicle high pressure charging port (Fig. 9).

Connect the low pressure hose (BLUE) to the vehicle low pressure charging port (Fig. 9).

Evacuate the system in accordance with the charging station procedures.

Switch the R143a air-conditioning charging station to the charging mode.

Charge the vehicle air-conditioning system with 1150 grammes of R-134a refrigerant.

Disconnect the charging station high and low pressure hoses from the charging port adaptors on the vehicle.

Fit protective caps to the low and high pressure adaptors on the vehicle; RED cap for the high pressure adaptor and the BLUE cap for the low pressure adaptor.

Retrofit Warning Labels

Using a suitable oil-resistant marker, fill in all retrofit details on the retrofit label supplied, including the name of the installing Dealer.

Tear off the appropriate language section or sections.

Remove the backing from the self-adhesive label and affix to a prominent position on the inner wing, covering the existing R-12 information label where possible.

Remove, destroy or permanently deface all original labels referring to R-12 refrigerant.

Post-fitting Checks

Using a dedicated HFC R-134a electronic analyser, check for non-visible leaks around the system; gross leakage will be evident by the escape of oil.

Reconnect the battery.

From inside the vehicle, run the engine at idle speed for fifteen minutes with the air-conditioning controls set to manual, full cooling and high fan speed to establish the performance of the air-conditioning system.

Reset the vehicle radio security code and the time clock.

Remove the protective wing covers.

Close the driver side door and the bonnet.

JAGUAR XJS 6.0 LITRE V12 AIR-CONDITIONING R-134a RETROFIT

Applicability

Jaguar 6.0 litre XJS models in the VIN range: 188105 to 190527.

Note: Vehicles covered by this instruction are fitted with a Sanden 709 compressor.

Pre-fitting Requirements

Open the driver side door and the bonnet.

Fit protective wing covers.

Turn the 1/4-turn fasteners securing the engine cover to the fuel rail.

Slacken the throttle cable locknut, noting its position to aid resetting.

Displace and remove the engine cover.

Displace and remove the 1/4-turn fastener receptacles from the fuel rail.

Reclaiming R-12 from the Air-conditioning System

Note: The reclamation of R-12 **must** be carried out in accordance with the instructions detailed in the operating manual provided with the charging station.

Position the R-12 air-conditioning charging station close to the vehicle.

Undo and remove the protective caps from the high and low pressure charging ports on the vehicle.

Position the R-12 air-conditioning charging station high and low pressure hoses to the vehicle.

Connect the low pressure hose (BLUE) to the vehicle low pressure charging port (1, Fig. 1).

Connect the high pressure hose (RED) to the vehicle high pressure charging port (2, Fig. 1).

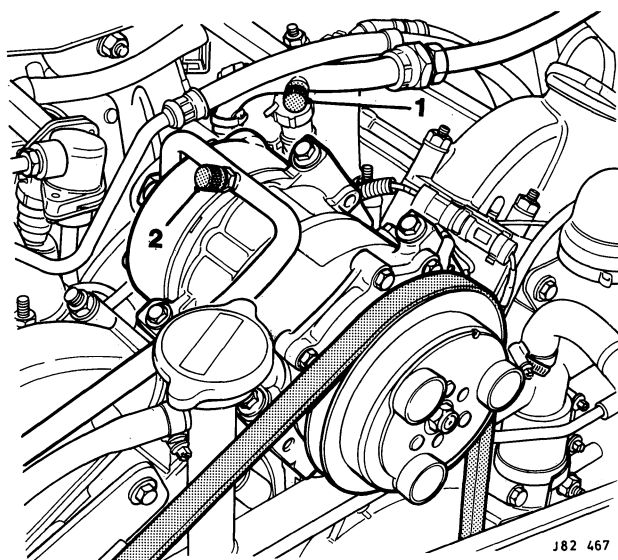

Fig. 1

From inside the vehicle, run the engine at idle speed for fifteen minutes with the air-conditioning controls set to manual, full cooling and high fan speed to establish the performance of the air-conditioning system. This operating condition also has the effect of collecting the majority of system mineral oil in the compressor.

Switch off the engine after fifteen minutes.

Disconnect the battery.

Switch the R-12 air-conditioning charging station to the recovery/reclaim mode.

Recover the R-12 refrigerant from the vehicle air-conditioning system.

Place suitable container under the charging station oil drain outlet and collect all oil recovered with the R-12 refrigerant during reclamation.

Isolate the R-12 air-conditioning charging station from the vehicle *in accordance with the instructions provided in the charging station operating manual.*

Removing the Air-conditioning System Compressor

Slacken the pivot bolt securing the drive belt tensioning idler pulley carrier (1, Fig. 2) to the mounting bracket.

Slacken the bolt securing the adjusting rod to the idler pulley carrier (4, Fig. 2).

Undo the adjusting rod adjustment locknut (3, Fig. 2).

Note: Pivot the pulley in towards the engine to release tension on the drive belt.

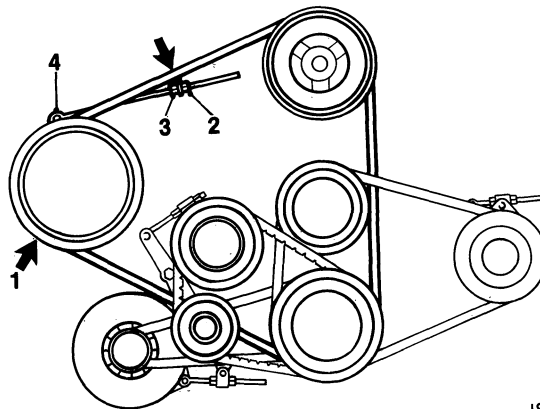

J82-349

Fig. 2

Displace and reposition the compressor drive belt.

Disconnect the drive clutch coil multi-plug connector.

Disconnect the compressor low pressure switch harness multi-plug.

Undo and remove the bolt and blanking plate (1, Fig. 3) securing the compressor hoses to the compressor.

Displace the discharge and suction hoses from the rear of the compressor.

Remove and discard the O-rings fitted between the hoses and the compressor.

Fit suitable blanking plugs to the open hoses to prevent the ingress of foreign material.

Fit a blanking plate (1, Fig. 3) to cover the compressor ports.

Fit and tighten a bolt to secure the clamping plate in position.

Undo and remove the bolts (2, Fig. 3) securing the compressor to its mounting bracket.

Displace and remove the compressor assembly and place on a clean workbench.

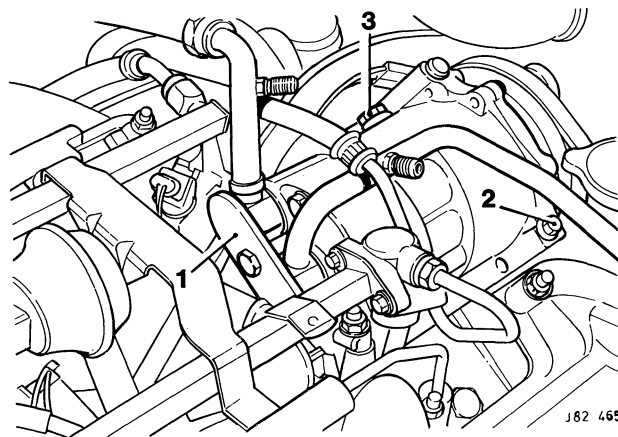

Fig. 3

Draining and Flushing the Compressor

Place a suitable measuring container on the workbench.

Undo and remove the bolt securing the blanking plate to the compressor.

Displace and remove the blanking plate.

Undo and remove the compressor sump plug (3, Fig. 3) situated on the left hand side of the compressor casing.

Tip the compressor and drain the compressor oil into the container.

Pour 100ml of Ester oil in a clean measuring vessel.

Pour the Ester oil from the measuring vessel into the compressor.

Manually work the oil around the compressor then drain and discard the oil from the compressor.

Compressor Front Seal Renewal

The front seal on this type of compressor must be removed because it is not compatible with R-134a refrigerant. The new, R-134a compatible, seal from the kit must be fitted in its place.

Secure the compressor in a suitable vice, clamping on the compressor body lugs.

Fit the drive clutch service tool JD166-1 (1, Fig. 4) to the compressor drive clutch and tighten the tool securing bolts (2, Fig. 4).

Fit the tommy bar JD166-2 (3, Fig. 4) to the drive clutch service tool JD166-1.

Undo and remove the clutch drive securing nut.

Fit tool JD166-3 to the clutch drive service tool JD166-1.

Reposition the tommy bar JD166-2 to engage the tool JD166-3.

Tighten the tool centre bolt (2, Fig 5) to remove the drive clutch.

Remove the drive clutch complete with the service tool from the compressor.

Set the tool centre bolt to its original position for future use.

Reposition the tommy bar JD166-2 to release JD166-3.

Remove tool JD166-3 from the clutch drive service tool JD166-1.

Undo and remove the bolts (2, Fig 4) securing the clutch drive service tool JD166-1.

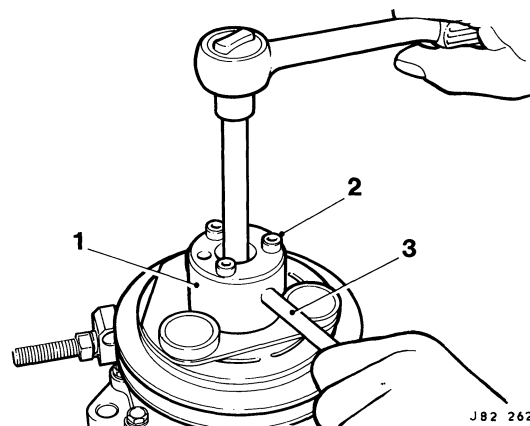

Fig. 4

Remove the clutch drive service tool from the drive clutch.

Place the clutch drive service tool aside.

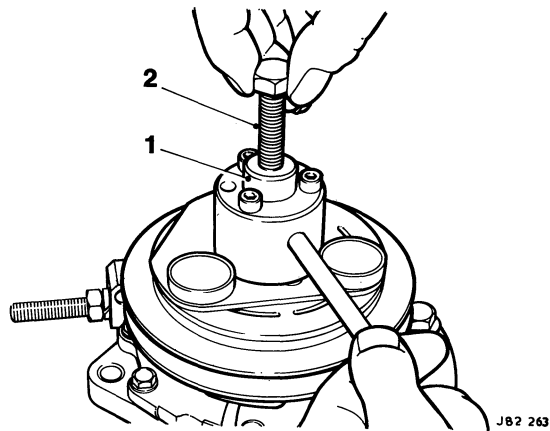

Fig. 5

Remove the clutch air gap adjustment shims from the compressor shaft.

Displace and remove the Woodruff key from the compressor shaft.

Displace and remove the seal seat retaining snap ring retaining the pulley on the compressor.

Fit tool JD167 (1, Fig. 6) to the seal seat, engaging the tangs of the tool in the groove in the seal seat (2, Fig. 6).

Remove the seal seat from the compressor.

Remove the tool JD167 from the seal seat.

Remove the O-ring from the seal seat.

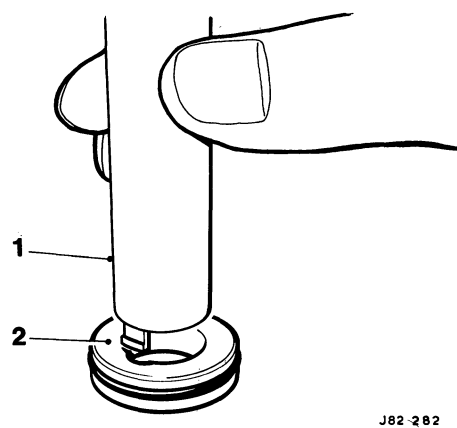

Fig. 6

Fit the tool JD168 (1, Fig. 7) to the seal, engaging the tangs of the tool with those in the seal, and remove the seal from the compressor using a twisting motion.

Place the seal seat aside.

Fit a new O-ring seal to a new seal seat.

Fit the seal seat projector tool JD164 (2, Fig. 7) to the compressor shaft.

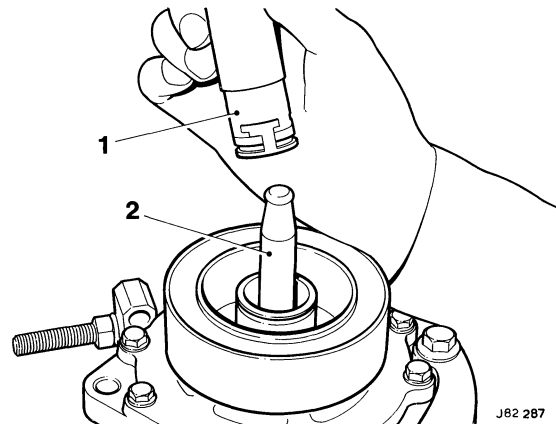

Fig. 7

Smear the new front seal seat and new O-ring with clean Ester oil.

Fit tool JD167 to the seal seat, engaging the tangs of the tool in the groove in the seal seat.

Fit and fully seat the seal seat to the compressor.

Disengage and remove the tool JD167 from the groove in the seal seat.

Remove the seal projector JD164 from the compressor shaft.

Fit and fully seat the seal seat retaining snap ring.

Fit and fully seat the felt ring.

Fit the Woodruff key.

Fit the clutch air gap adjustment shims.

Fit and align the clutch drive to the keyway.

Fit and fully seat the clutch drive to the compressor shaft using a suitable piece of tubing.

Remove the tubing.

Fit the clutch drive service tool JD166-1 to the clutch drive.

Fit and tighten the bolts to attach the clutch drive service tool to the clutch drive.

Fit the tommy bar JD166-2 to the clutch drive service tool JD166-1.

Fit and tighten the clutch drive securing bolt.

Undo and remove the bolts securing the clutch drive service tool to the clutch drive.

Remove the tommy bar JD166-2 and the clutch drive service tool JD166-1 from the clutch drive.

Check the air gap (refer to the workshop manual for recommended air gap).

Remove the compressor from the vice.

Recharging the Compressor

Pour 135ml of Ester oil into a clean measuring vessel.

Pour the Ester oil from the measuring vessel into the compressor.

Fit and fully tighten the compressor sump plug.

Fit and align the compressor blanking plate.

Fit and tighten the bolt to secure the blanking plate to the compressor.

Installing the Air-conditioning System Compressor

Fit and align the Ester-charged compressor to its mounting brackets.

Fit and fully tighten the bolts to secure the compressor to its mounting brackets.

Connect the low pressure switch multi-plug connector to the low pressure switch at the rear of the compressor.

Undo and remove the bolt securing the compressor port blanking plate to the compressor.

Displace and remove the blanking plate from the compressor.

Fit new O-rings to the compressor.

Displace and remove the blanking plugs from the compressor hoses.

Fit and fully seat the hoses to the compressor.

Fit and tighten the bolt securing the compressor hose.

Connect the clutch coil harness multi-plug.

Fit and align the compressor drive belt to the compressor.

Tighten the adjusting rod adjustment locknut to give the correct adjustment (refer to the workshop manual for the correct tension figure).

Tighten the adjusting rod locknut to preserve drive belt setting.

Tighten the bolt to secure the adjusting rod to the idler pulley carrier.

Tighten the pivot bolt to secure the idler pulley carrier to the mounting bracket.

Removing the Existing Receiver–Drier Bottle

Undo the liquid line union nut at its connection on the receiver–drier bottle (Fig. 8).

Undo the condenser pipe union nut at its connection on the receiver–drier bottle.

Undo and remove the nuts securing the receiver–drier bottle top rail mounting brackets to the top rail.

Displace the bleed pipe securing clips from their studs.

Undo and remove the clamping nuts and bolts securing the receiver–drier into its top rail mounting brackets.

Displace and reposition the receiver–drier bottle top rail mounting brackets from the top rail.

Disconnect the liquid line.

Remove and discard the liquid line O–ring seal.

Disconnect the receiver–drier bottle from the condenser pipe.

Remove and discard the receiver–drier bottle pipe O–ring seal.

Displace and remove the receiver–drier bottle.

Fit suitable blanking plugs to the receiver–drier bottle and pipes.

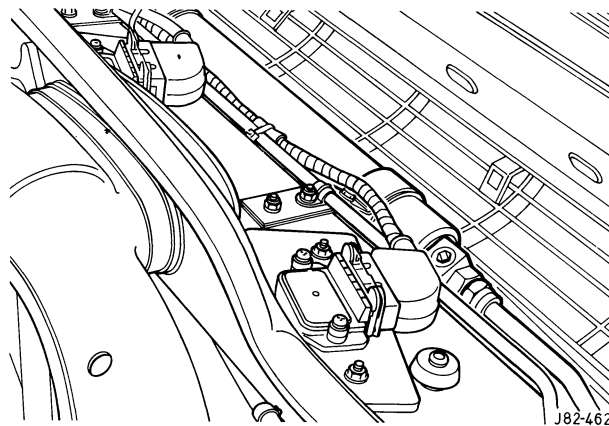

Fig. 8

Fitting a New R–134a Compatible Receiver–Drier Bottle

Place a new receiver–drier bottle on the workbench.

Remove the backing paper from the receiver–drier bottle mounting rubbers.

Fit and align the mounting rubbers to the new receiver–drier bottle.

Fit and align the top rail mounting brackets to the receiver–drier, ensuring that the sight glass is facing upwards.

Undo and remove the receiver–drier bottle protective caps.

Remove the blanking plugs from the pipes.

Fit new O-rings seals to the pipes.

Place the receiver-drier bottle to the vehicle.

Connect the pipes to the receiver-drier bottle.

Fit but do not tighten the pipe union nuts.

Position the receiver-drier bottle mounting brackets to the top rail.

Position the bleed pipe mounting clips to the top rail studs.

Fit and tighten the receiver-drier bottle mounting bracket securing nuts.

Fit and tighten the mounting bracket clamping nuts and bolts.

Fully tighten union nuts to secure the pipes to the receiver-drier bottle.

Fitting R-134a Adaptors to the R-12 Fittings

The charge port service adaptor threads are coated with thread-locking fluid. Ensure that the threads of the existing R-12 charging valves are cleaned before fitting the new adaptors.

Undo and remove the Schrader valve from the R-12 high pressure connector on the discharge hose. This must be removed to enable the R-134a elbow connector to function properly.

Fit and tighten an R-134a refrigerant high pressure elbow adaptor (RED) (Fig. 9) to the R-12 high pressure connector on the discharge hose.

Fit and tighten an R-134a refrigerant straight low pressure adaptor (BLUE) (Fig. 9) to the R-12 low pressure connector on the suction hose.

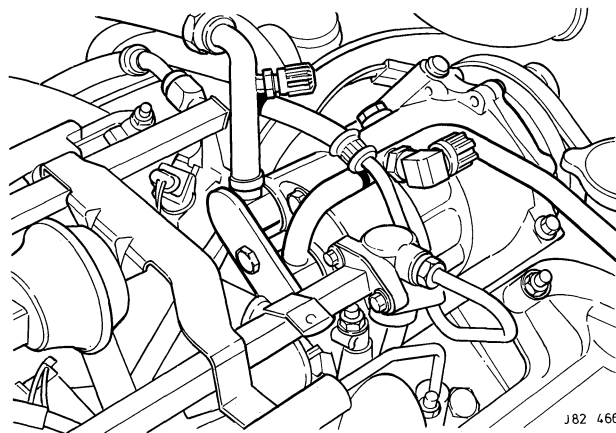

Fig. 9

Charging the Vehicle Air-conditioning System with R-134a Refrigerant

Note: Charging of the air-conditioning charging station and the vehicles air-conditioning system **must** be carried out in accordance with the instructions detailed in the operating manual provided with the charging station.

Position the R-134a air-conditioning charging station close to the vehicle and R-134a gas supply cylinder.

Charge the R-134a air-conditioning charging station with 1150 grammes of R-134a refrigerant from a gas supply cylinder.

Disconnect the air-conditioning charging station from the gas supply cylinder.

Undo and remove the protective caps from the high and low pressure charging ports on the vehicle.

Position the R-134a air-conditioning charging station high and low pressure hoses to the vehicle.

Connect the high pressure hose (RED) to the vehicle high pressure charging port (Fig. 9).

Connect the low pressure hose (BLUE) to the vehicle low pressure charging port (Fig. 9).

Evacuate the system in accordance with the charging station procedures.

Switch the R143a air-conditioning charging station to the charging mode.

Charge the vehicle air-conditioning system with 1150 grammes of R-134a refrigerant.

Disconnect the charging station high and low pressure hoses from the charging port adaptors on the vehicle.

Fit protective caps to the low and high pressure adaptors on the vehicle; RED cap for the high pressure adaptor and the BLUE cap for the low pressure adaptor.

Retrofit Warning Labels

Using a suitable oil-resistant marker, fill in all retrofit details on the retrofit label supplied, including the name of the installing Dealer.

Tear off the appropriate language section or sections.

Remove the backing from the self-adhesive label and affix to a prominent position on the inner wing, covering the existing R-12 information label where possible.

Remove, destroy or permanently deface all original labels referring to R-12 refrigerant.

Refitting Engine Parts

Fit $\frac{1}{4}$ -turn fastener receptacles to the fuel rail.

Fit and seat the engine cover to the fuel rail.

Position the outer throttle cable to the abutment bracket.

Tighten the throttle cable locknut until its original setting is achieved (noted during removal).

Fit and turn the $\frac{1}{4}$ -turn fasteners to secure the engine cover to the fuel rail; these require only firm thumb pressure to secure them in position.

Post-fitting Checks

Using a dedicated HFC R-134a electronic analyser, check for non-visible leaks around the system; gross leakage will be evident by the escape of oil.

Reconnect the battery.

From inside the vehicle, run the engine at idle speed for fifteen minutes with the air-conditioning controls set to manual, full cooling and high fan speed to establish the performance of the air-conditioning system.

Reset the vehicle radio security code and the time clock.

Remove the protective wing covers.

Close the driver side door and the bonnet.

JAGUAR XJS 3.6 LITRE 6 CYLINDER (PRE-92MY) AIR-CONDITIONING R-134a RETROFIT

Applicability

Jaguar XJS models in the VIN range: 112586 to 179739 (Pre-92MY).

Note: Vehicles covered by this instruction are fitted with a Harrison compressor.

Pre-fitting Requirements

Open the driver side door and the bonnet.

Fit protective wing covers.

Reclaiming R-12 from the Air-conditioning System

Note: The reclamation **must** be carried out in accordance with the instructions detailed in the operating manual provided with the charging station.

Position the R-12 air-conditioning charging station close to the vehicle.

Undo and remove the protective caps from the high and low pressure charging ports on the vehicle.

Position the R-12 air-conditioning charging station high and low pressure hoses to the vehicle.

Connect the low pressure hose (BLUE) to the vehicle low pressure charging port (1, Fig. 1).

Connect the high pressure hose (RED) to the vehicle high pressure charging port (2, Fig. 1).

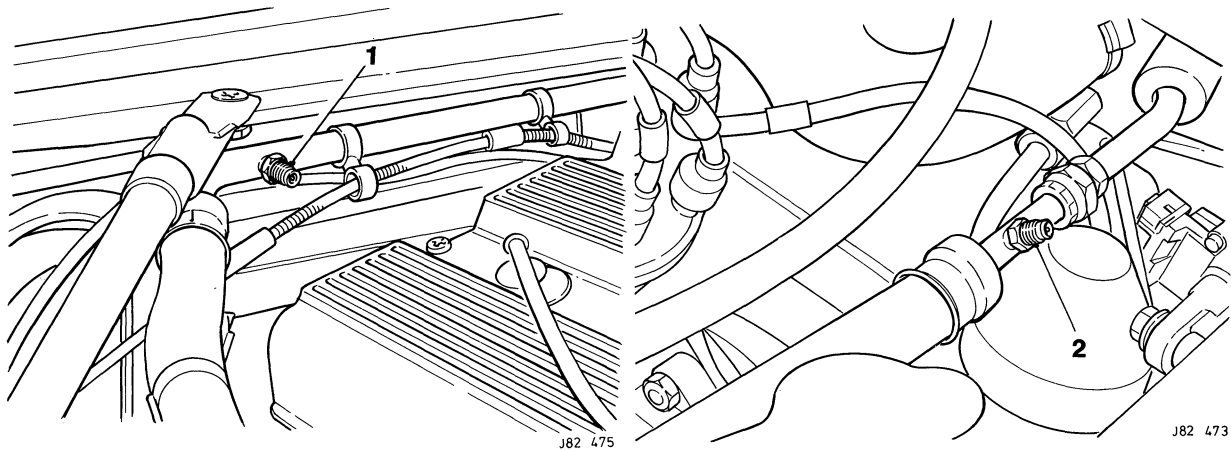

Fig. 1

From inside the vehicle, run the engine at idle speed for fifteen minutes with the air-conditioning controls set to manual, full cooling and high fan speed to establish the performance of the air-conditioning system. This operating condition also has the effect of collecting the majority of system mineral oil in the compressor.

Switch off the engine after fifteen minutes.

Disconnect the battery.

Switch the R-12 air-conditioning charging station to the recovery/reclaim mode.

Recover the R-12 refrigerant from the vehicle air-conditioning system.

Place suitable container under the charging station oil drain outlet and collect all oil recovered with the R-12 refrigerant during reclamation.

Isolate the R-12 air-conditioning charging station from the vehicle *in accordance with the instructions provided in the charging station operating manual.*

Removing the Air-conditioning System Compressor

Undo and remove the bolt securing the high and low pressure hoses to the compressor.

Remove the clamping plate.

Fit suitable blanking plugs to the open ends of the hoses.

Remove and discard the compressor O-ring seals.

Fit the hose clamping plate to cover the compressor outlet ports.

Fit and tighten a dummy bolt to secure the hose blanking plate to the compressor.

Disconnect the superheat switch feed wire from the rear of the compressor.

Slacken the compressor pivot bolts (1 & 2, Fig. 2).

Slacken the adjusting nuts (3 & 4, Fig. 2) on the compressor drive belt link.

Undo and remove the bolts securing the compressor drive belt link trunnion (5, Fig. 2)

Displace the adjusting link assembly upwards.

Pivot the compressor toward the engine.

Displace and remove the drive belt.

Remove the compressor pivot bolts.

Remove the rear pivot bolt spacers (6 & 7, Fig. 2).

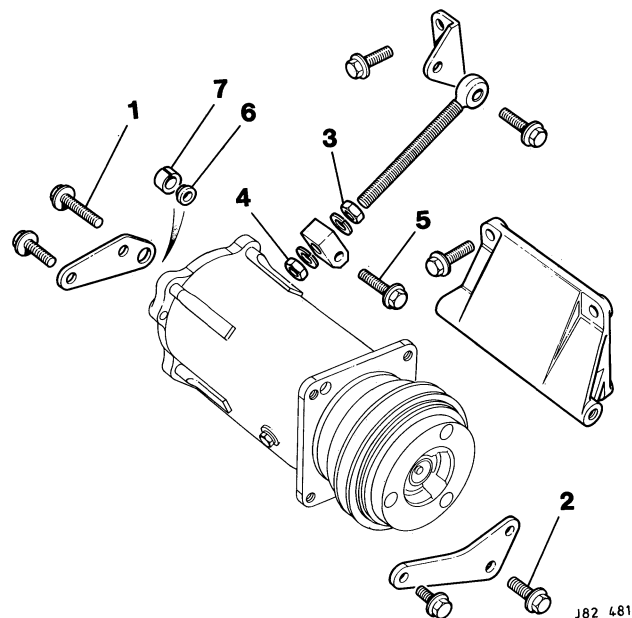

Fig. 2

Displace the compressor rearward and disconnect the clutch feed wires and the superheat switch feed wires (1 & 2, Fig. 3).

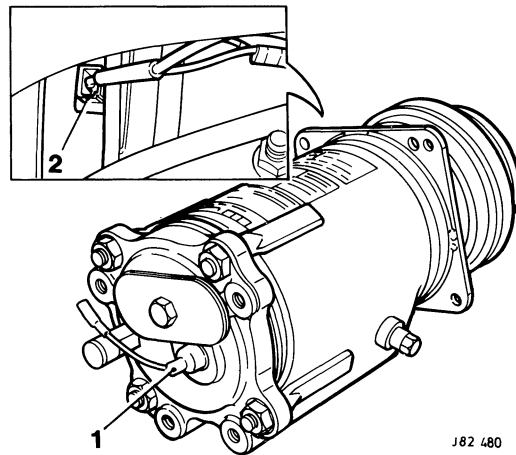

Fig. 3

While keeping the compressor horizontal, displace and remove it from the vehicle.

Place the compressor on a clean workbench.

Draining, Flushing and Recharging the Compressor

Place a suitable measuring container on the workbench.

Undo and remove the bolt securing the blanking plate to the compressor.

Displace and remove the blanking plate.

Undo and remove the compressor sump plug (1, Fig. 4).

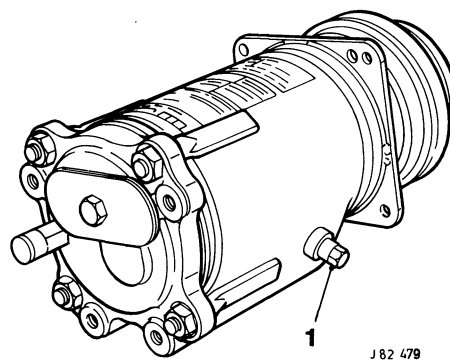

Fig. 4

Tip the compressor and drain compressor oil into a suitable container.

Pour 100ml of Ester oil into a clean measuring vessel.

Pour the Ester oil from the measuring vessel into the compressor.

Manually work the oil around the compressor then drain and discard the oil from the compressor.

Recharging the Compressor

Pour 284ml of Ester oil into a clean measuring vessel.

Pour the Ester oil from the measuring vessel into the compressor.

Fit and fully tighten the compressor sump plug.

Installing the Air-conditioning System Compressor

Fit and align the compressor blanking plate.

Fit and tighten the bolt to secure the blanking plate to the compressor.

While keeping the compressor in a horizontal position, fit and seat the Ester-charged compressor to the engine.

Connect the compressor clutch feed wires.

Fit but do not tighten the compressor front securing bolt.

Fit the rear pivot bolt spacers.

Fit but do not tighten the rear pivot bolt.

Fit and locate the drive belt over the pulleys.

Reposition the drive belt adjusting link assembly.

Fit but do not tighten the bolt to the link trunnion.

Adjust the tension on the drive belt. Refer to the workshop manual for the correct tension figure.

Fit and fully tighten the bolts to secure the link arm.

Fully tighten the pivot bolts.

Connect the superheat switch feed wires.

Remove the temporary blanking plugs from the hoses.

Undo and remove the dummy bolt securing the clamping plate to the compressor.

Displace and remove the clamping plate.

Fit and fully seat new O-ring seals to the compressor.

Connect the high and low pressure hoses to the compressor.

Fit the clamping plate to the compressor.

Fit and fully tighten the bolt to secure the clamping plate.

Removing the Existing Receiver–Drier Bottle

Undo the liquid line union nut at its connection on the receiver–drier bottle Fig. 5.

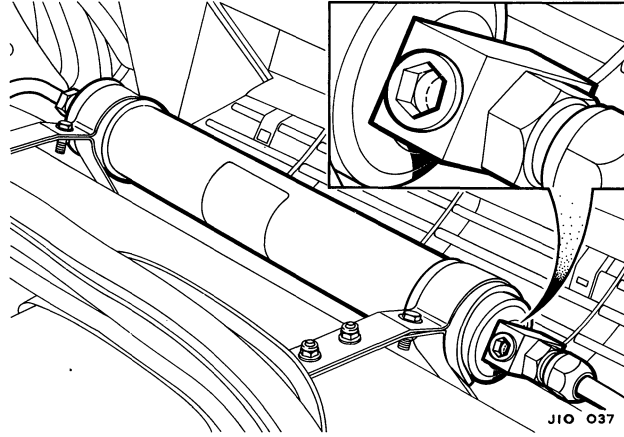

Fig. 5

Undo the condenser pipe union nut at its connection on the receiver–drier bottle.

Undo and remove the nuts securing the receiver–drier bottle top rail mounting brackets to the top rail.

Displace the bleed pipe securing clips from their studs.

Undo and remove the clamping nuts and bolts securing the receiver–drier into its top rail mounting brackets.

Displace and reposition the receiver–drier bottle top rail mounting brackets from the top rail.

Disconnect the liquid line.

Remove and discard the liquid line O–ring seal.

Disconnect the receiver–drier bottle from the condenser pipe.

Remove and discard the receiver–drier bottle pipe O–ring seal.

Displace and remove the receiver–drier bottle.

Fit suitable blanking plugs to the receiver–drier bottle and pipes.

Fitting a New R–134a Compatible Receiver–Drier Bottle

Place a new receiver–drier bottle on the workbench.

Remove the backing paper from the receiver–drier bottle mounting rubbers.

Fit and align the mounting rubbers to the new receiver–drier bottle.

Fit and align the top rail mounting brackets to the receiver–drier, ensuring that the sight glass is facing upwards.

Undo and remove the receiver–drier bottle protective caps.

Remove the blanking plugs from the pipes.

Fit new O-rings seals to the pipes.

Place the receiver-drier bottle to the vehicle.

Connect the pipes to the receiver-drier bottle.

Fit but do not tighten the pipe union nuts.

Position the receiver-drier bottle mounting brackets to the top rail.

Position the bleed pipe mounting clips to the top rail studs.

Fit and tighten the receiver-drier bottle mounting bracket securing nuts.

Fit and tighten the mounting bracket clamping nuts and bolts.

Fully tighten union nuts to secure the pipes to the receiver-drier bottle.

Fitting R-134a Adaptors to the R-12 Fittings

The charge port service adaptor threads are coated with thread-locking fluid. Ensure that the threads of the existing R-12 charging valves are cleaned before fitting the new adaptors.

Fit and tighten a straight R-134a refrigerant high pressure adaptor (RED) (Fig. 6) to the R-12 high pressure connector on the discharge hose.

Note: At 91MY, undo and remove the Schrader valve from the R-12 high pressure connector on the discharge hose and fit an R-134a refrigerant high pressure elbow adaptor to the R-12 connector. The Schrader valve must be removed to enable the R-134a elbow connector to function properly.

Fit and tighten a straight R-134a refrigerant low pressure adaptor (BLUE) (Fig. 6) to the R-12 low pressure connector on the suction hose.

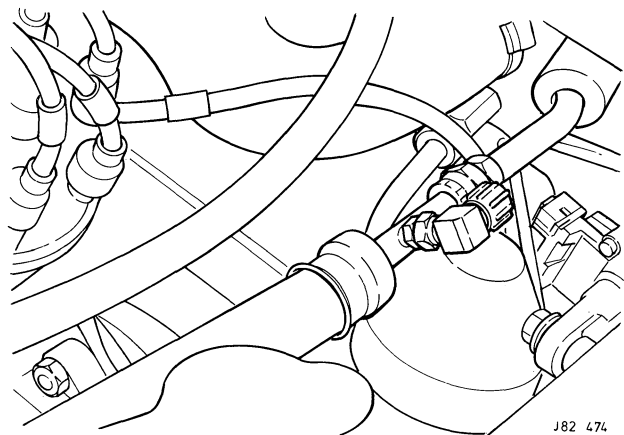
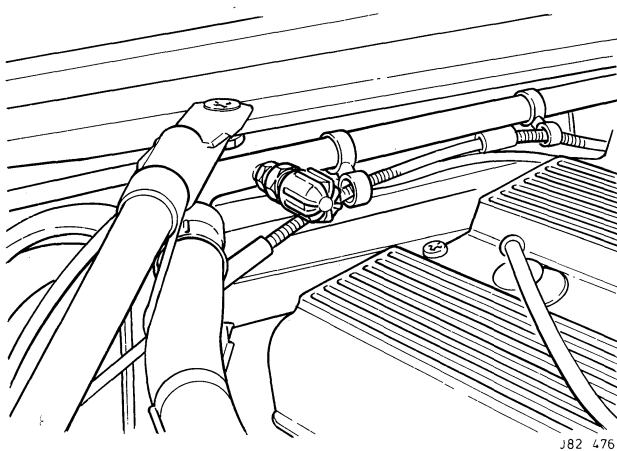

Fig. 6

Charging the Vehicle Air-conditioning System with R-134a Refrigerant

Note: Charging of the air-conditioning charging station and the vehicles air-conditioning system **must** be carried out in accordance with the instructions detailed in the operating manual provided with the charging station.

Position the R-134a air-conditioning charging station close to the vehicle and R-134a gas supply cylinder.

Charge the R-134a air-conditioning charging station with 1150 grammes of R-134a refrigerant from a gas supply cylinder.

Disconnect the air-conditioning charging station from the gas supply cylinder.

Undo and remove the protective caps from the high and low pressure charging ports on the vehicle.

Position the R-134a air-conditioning charging station high and low pressure hoses to the vehicle.

Connect the high pressure hose (RED) to the vehicle high pressure charging port (Fig. 6).

Connect the low pressure hose (BLUE) to the vehicle low pressure charging port (Fig. 6).

Evacuate the system in accordance with the charging station procedures.

Switch the R143a air-conditioning charging station to the charging mode.

Charge the vehicle air-conditioning system with 1150 grammes of R-134a refrigerant.

Disconnect the charging station high and low pressure hoses from the charging port adaptors on the vehicle.

Fit protective caps to the low and high pressure adaptors on the vehicle; RED cap for the high pressure adaptor and the BLUE cap for the low pressure adaptor.

Retrofit Warning Labels

Using a suitable oil-resistant marker, fill in all retrofit details on the retrofit label supplied, including the name of the installing Dealer.

Tear off the appropriate language section or sections.

Remove the backing from the self-adhesive label and affix to a prominent position on the inner wing, covering the existing R-12 information label where possible.

Remove, destroy or permanently deface all original labels referring to R-12 refrigerant.

Post-fitting Checks

Using a dedicated HFC R-134a electronic analyser, check for non-visible leaks around the system; gross leakage will be evident by the escape of oil.

Reconnect the battery.

From inside the vehicle, run the engine at idle speed for fifteen minutes with the air-conditioning controls set to manual, full cooling and high fan speed to establish the performance of the air-conditioning system.

Reset the vehicle radio security code and the time clock.

Remove the protective wing covers.

Close the driver side door and the bonnet.

JAGUAR XJS 4.0 LITRE 6 CYLINDER (POST-92MY) AIR-CONDITIONING R-134a RETROFIT

Applicability

Jaguar XJS models in the VIN range: 179740 to 190527 (Post-92MY).

Note: Vehicles covered by this instruction are fitted with a Sanden 709 compressor.

Pre-fitting Requirements

Open the driver side door and the bonnet.

Fit protective wing covers.

Reclaiming R-12 from the Air-conditioning System

Note: The reclamation of R-12 **must** be carried out in accordance with the instructions detailed in the operating manual provided with the charging station.

Position the R-12 air-conditioning charging station close to the vehicle.

Undo and remove the protective caps from the high and low pressure charging ports on the vehicle.

Position the R-12 air-conditioning charging station high and low pressure hoses to the vehicle.

Connect the low pressure hose (BLUE) to the vehicle low pressure charging port (1, Fig. 1).

Connect the high pressure hose (RED) to the vehicle high pressure charging port (2, Fig. 1).

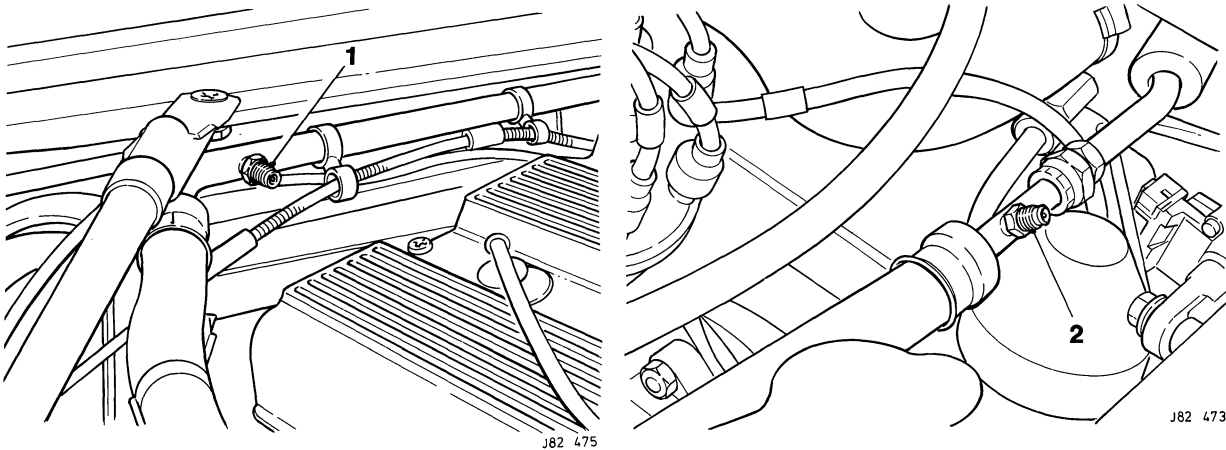

Fig. 1

From inside the vehicle, run the engine at idle speed for fifteen minutes with the air-conditioning controls set to manual, full cooling and high fan speed to establish the performance of the air-conditioning system. This operating condition also has the effect of collecting the majority of system mineral oil in the compressor.

Switch off the engine after fifteen minutes.

Disconnect the battery.

Switch the R-12 air-conditioning charging station to the recovery/reclaim mode.

Recover the R-12 refrigerant from the vehicle air-conditioning system.

Place suitable container under the charging station oil drain outlet and collect all oil recovered with the R-12 refrigerant during reclamation.

Isolate the R-12 air-conditioning charging station from the vehicle *in accordance with the instructions provided in the charging station operating manual.*

Removing the Air-conditioning System Compressor

Undo and remove the bolt securing the clamping plate to the compressor.

Displace and remove the clamping plate.

Disconnect the high pressure hose from the compressor.

Fit a suitable blanking plug to the open end of the high pressure hose.

Disconnect the low pressure hose from the compressor.

Fit a suitable blanking plug to the open end of the low pressure hose.

Remove and discard the compressor O-ring seals.

Fit the clamping plate to cover the compressor ports.

Fit and tighten a dummy bolt to secure the blanking plate to the compressor.

Cut and remove all ratchet straps securing harnesses to the compressor.

Disconnect the compressor feed multi-plug connector (1, Fig. 2).

Reposition the rubber cover from the compressor switch.

Disconnect the LUCAR connectors (2, Fig. 2) from the compressor switch.

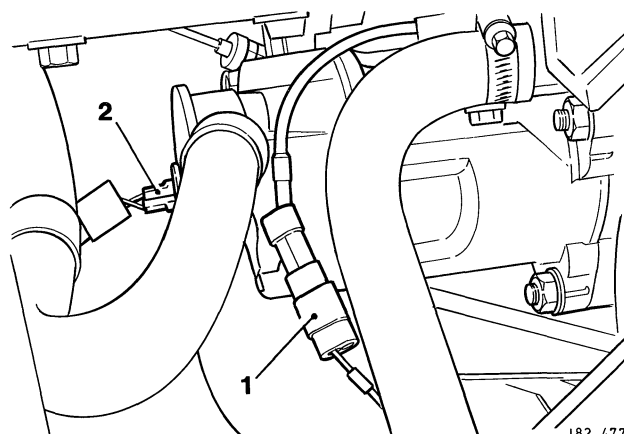

Fig. 2

Slacken the compressor upper pivot bolt.

Raise the vehicle on a 4-post ramp.

From beneath the vehicle, slacken the bolt (1, Fig. 3) securing the compressor front adjuster.

Slacken the bolt (2, Fig. 3) securing the compressor to the rear slide plate.

Slacken the compressor lower pivot bolt (3, Fig. 3).

Undo the compressor adjuster nut (4, Fig. 3) until the drive belt can be removed.

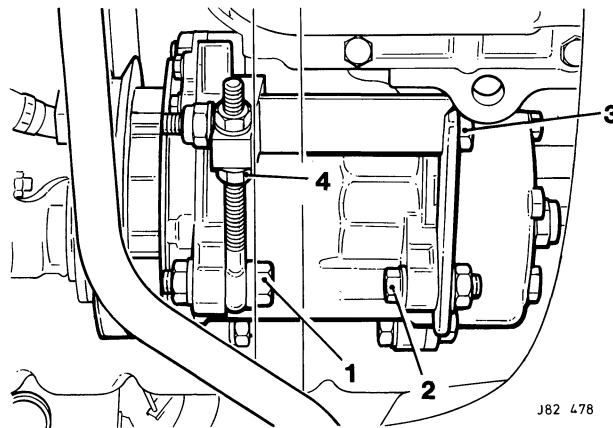

Fig. 3

Displace and remove the compressor drive belt.

From above, while supporting the compressor, remove the compressor upper pivot bolt.

Displace and remove the compressor from the engine.

Place the compressor on a clean workbench.

Draining and Flushing the Compressor

Place a suitable measuring container on the workbench.

Undo and remove the bolt securing the blanking plate to the compressor.

Displace and remove the blanking plate.

Undo and remove the compressor sump plug (1, Fig. 4) situated on the left hand side of the compressor casing.

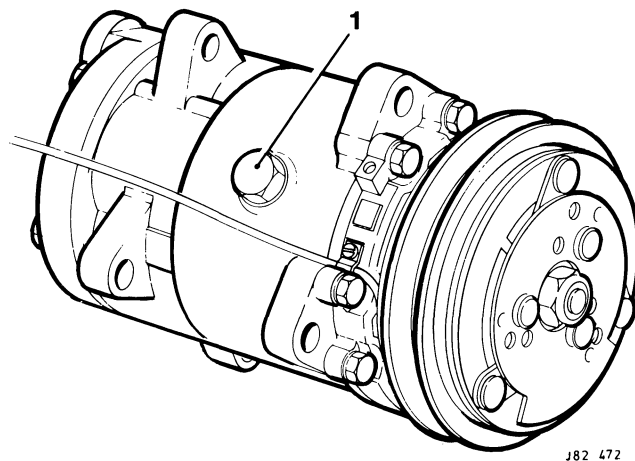

Fig. 4

Tip the compressor and drain the compressor oil into a container.

Pour 100ml of Ester oil into a clean measuring vessel.

Pour the Ester oil from the measuring vessel into the compressor.

Manually work the oil around the compressor then drain and discard the oil from the compressor.

Compressor Front Seal Renewal

The front seal on this type of compressor must be removed because it is not compatible with R-134a refrigerant. The new, R-134a compatible, seal from the kit must be fitted in its place.

Secure the compressor in a suitable vice, clamping on the compressor body lugs.

Fit the drive clutch service tool JD166-1 (1, Fig. 5) to the compressor drive clutch and tighten the tool securing bolts (2, Fig. 5).

Fit the tommy bar JD166-2 (3, Fig. 5) to the drive clutch service tool JD166-1.

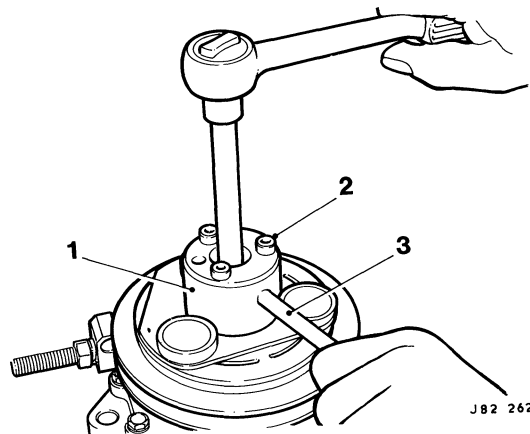

Fig. 5

Undo and remove the clutch drive securing nut.

Fit tool JD166-3 (1, Fig. 6) to the clutch drive service tool JD166-1.

Reposition the tommy bar JD166-2 (Fig. 6) to engage the tool JD166-3.

Tighten the tool centre bolt (2, Fig. 6) to remove the drive clutch.

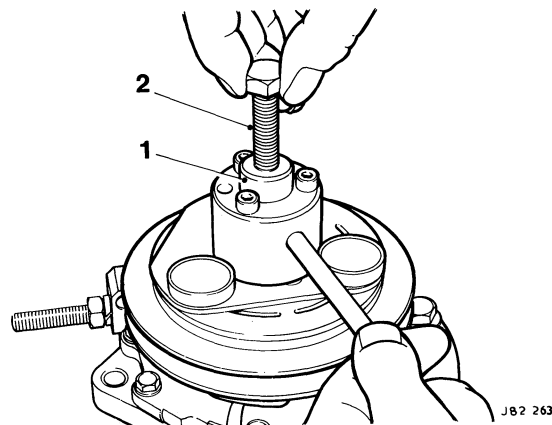

Fig. 6

Remove the drive clutch complete with the service tool from the compressor.

Set the tool centre bolt to its original position for future use.

Reposition the tommy bar JD166-2 to release JD166-3.

Remove tool JD166-3 from the clutch drive service tool JD166-1.

Undo and remove the bolts securing the clutch drive service tool JD166-1.

Remove the clutch drive service tool JD166-1 from the drive clutch.

Place the clutch drive service tool aside.

Remove the clutch air gap adjustment shims from the compressor shaft.

Displace and remove the Woodruff key from the compressor shaft.

Displace and remove the felt ring.

Displace and remove the seal seat snap ring retaining the pulley on the compressor.

Fit tool JD167 (1, Fig. 7) to the seal seat, engaging the tangs of the tool in the groove in the seal seat (2, Fig. 7).

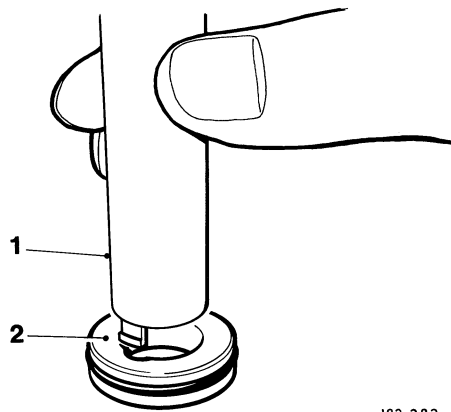

J82 282

Fig. 7

Remove the seal seat from the compressor.

Remove the tool JD167 from the seal seat.

Remove the O-ring from the seal seat.

Fit the tool JD168 to the front seal.

Engage the tangs of the tool with those in the seal seat and, using a twisting action, remove the seal from the compressor.

Remove the seal from the tool.

Fit the seal seat protector tool JD164 (2, Fig. 8) to the compressor shaft.

Smear the new front seal with clean Ester oil.

Fit a new front seal to tool JD168.

Using a twisting action, fit and fully seat the seal to the compressor (1, Fig. 8).

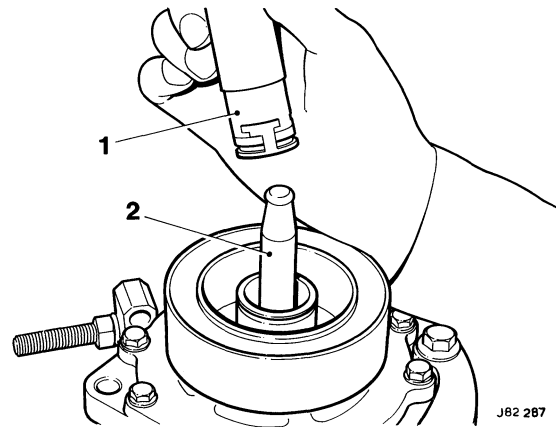

Fig. 8

Disengage and remove the tool JD168 from the seal.

Fit and fully seat the a new O-ring seal to the seal seat.

Fit tool JD167 to the seal seat, engaging the tangs of the tool in the groove in the seal seat.

Fit and fully seat the snap ring to retain the seal seat.

Fit and fully seat the felt ring.

Fit the Woodruff key.

Fit the clutch air gap adjustment shims.

Fit and align the clutch drive to the keyway.

Fit and fully seat the clutch drive to the compressor shaft using a suitable piece of tubing.

Remove the tubing.

Fit the clutch drive service tool JD166-1 to the clutch drive.

Fit and tighten the bolts to attach the clutch drive service tool to the clutch drive.

Fit the tommy bar JD166-2 to the clutch drive service tool JD166-1.

Fit and tighten the clutch drive securing nut.

Undo and remove the bolts securing the clutch drive service tool to the clutch drive.

Remove the tommy bar JD166-2 and the clutch drive service tool JD166-1 from the clutch drive.

Check the air gap (refer to the workshop manual for recommended air gap).

Remove the compressor from the vice.

Recharging the Compressor

- Pour 135ml of Ester oil into a clean measuring vessel.
- Pour the Ester oil from the measuring vessel into the compressor.
- Fit and fully tighten the compressor sump plug.
- Fit and align the blanking plate to cover the ports in the compressor.
- Fit and tighten the bolt to secure the blanking plate to the compressor.

Installing the Air-conditioning System Compressor

- Fit and align the Ester-charged compressor assembly to the engine.
- Fit but do not tighten the upper pivot bolt.
- From beneath the vehicle, align the compressor to its lower mounting.
- Fit but do not fully seat the lower pivot bolt.
- Align the adjuster trunnion to the mounting.
- Fully seat the lower pivot bolt.
- Refit the compressor drive belt.
- Pivot the compressor to increase tension on the drive belt.
- Tighten the adjuster adjustment nut to obtain the correct tension (refer to the workshop manual for the correct tension figure).
- Tighten the adjuster locknut.
- Fully tighten the lower pivot bolt.
- Fully tighten the bolt to secure the adjuster to the compressor.
- Fully tighten the bolt to secure the rear slide plate to the compressor.
- Lower the vehicle to ground level.
- From within the engine compartment, tighten the upper pivot bolt.
- Reconnect the LUCAR connectors to the compressor pressure switch.
- Reposition the switch rubber cover.
- Reconnect the compressor multi-plug connector.
- Using ratchet straps as necessary, secure adjacent harnesses to the compressor.
- Undo and remove the bolt securing the clamping plate to the compressor.
- Displace and remove the clamping plate from the compressor.
- Fit new O-ring seals to the compressor.
- Displace and remove the blanking plugs from the high and low pressure hoses.
- Fit and fully seat the hoses to the compressor.

Fit and align the hose clamping plate to the compressor.

Fit and tighten the bolt to secure the clamping plate.

Removing the Existing Receiver–Drier Bottle

Undo the liquid line union nut at its connection on the receiver–drier bottle (Fig. 9).

Undo the condenser pipe union nut at its connection on the receiver–drier bottle.

Undo and remove the nuts securing the receiver–drier bottle top rail mounting brackets to the top rail.

Displace the bleed pipe securing clips from their studs.

Undo and remove the clamping nuts and bolts securing the receiver–drier into its top rail mounting brackets.

Displace and reposition the receiver–drier bottle top rail mounting brackets from the top rail.

Disconnect the liquid line.

Remove and discard the liquid line O–ring seal.

Disconnect the receiver–drier bottle from the condenser pipe.

Remove and discard the receiver–drier bottle pipe O–ring seal.

Displace and remove the receiver–drier bottle.

Fit suitable blanking plugs to the receiver–drier bottle and pipes.

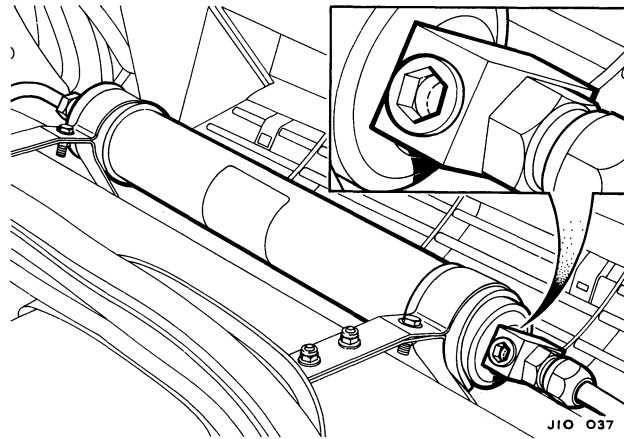

Fig. 9

Fitting a New R–134a Compatible Receiver–Drier Bottle

Place a new receiver–drier bottle on the workbench.

Remove the backing paper from the receiver–drier bottle mounting rubbers.

Fit and align the mounting rubbers to the new receiver–drier bottle.

Fit and align the top rail mounting brackets to the receiver–drier, ensuring that the sight glass is facing upwards.

Undo and remove the receiver–drier bottle protective caps.

Remove the blanking plugs from the pipes.

Fit new O–ring seals to the pipes.

Place the receiver–drier bottle to the vehicle.

Connect the pipes to the receiver–drier bottle.

Fit but do not tighten the pipe union nuts.

Position the receiver–drier bottle mounting brackets to the top rail.

Position the bleed pipe mounting clips to the top rail studs.

Fit and tighten the receiver–drier bottle mounting bracket securing nuts.

Fit and tighten the mounting bracket clamping nuts and bolts.

Fully tighten union nuts to secure the pipes to the receiver–drier bottle.

Fitting R–134a Adaptors to the R–12 Fittings

The charge port service adaptor threads are coated with thread–locking fluid. Ensure that the threads of the existing R–12 charging valves are cleaned before fitting the new adaptors.

Undo and remove the Schrader valve from the R–12 high pressure connector on the discharge hose. This must be removed to enable the R–134a elbow connector to function properly.

Fit and tighten an R–134a refrigerant high pressure elbow adaptor (RED) (Fig. 10) to the R–12 high pressure connector on the discharge hose.

Fit and tighten an R–134a refrigerant straight low pressure adaptor (BLUE) (Fig. 10) to the R–12 low pressure connector on the suction hose.

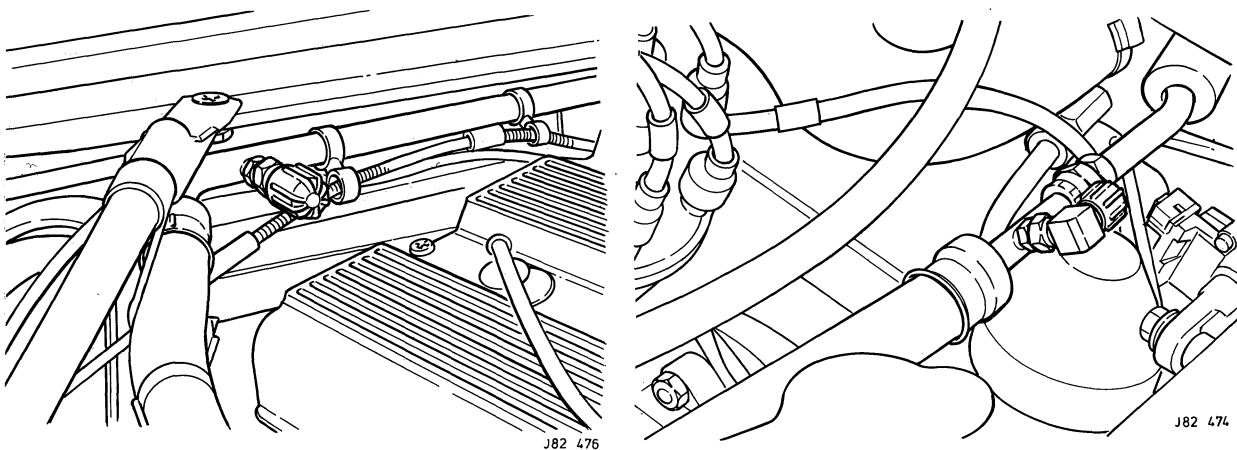

Fig. 10

Charging the Vehicle Air-conditioning System with R-134a Refrigerant

Note: Charging of the air-conditioning charging station and the vehicles air-conditioning system **must** be carried out in accordance with the instructions detailed in the operating manual provided with the charging station.

Position the R-134a air-conditioning charging station close to the vehicle and R-134a gas supply cylinder.

Charge the R-134a air-conditioning charging station with 1150 grammes of R-134a refrigerant from a gas supply cylinder.

Disconnect the air-conditioning charging station from the gas supply cylinder.

Undo and remove the protective caps from the high and low pressure charging ports on the vehicle.

Position the R-134a air-conditioning charging station high and low pressure hoses to the vehicle.

Connect the high pressure hose (RED) to the vehicle high pressure charging port (Fig. 10).

Connect the low pressure hose (BLUE) to the vehicle low pressure charging port (Fig. 10).

Evacuate the system in accordance with the charging station procedures.

Switch the R143a air-conditioning charging station to the charging mode.

Charge the vehicle air-conditioning system with 1150 grammes of R-134a refrigerant.

Disconnect the charging station high and low pressure hoses from the charging port adaptors on the vehicle.

Fit protective caps to the low and high pressure adaptors on the vehicle; RED cap for the high pressure adaptor and the BLUE cap for the low pressure adaptor.

Retrofit Warning Labels

Using a suitable oil-resistant marker, fill in all retrofit details on the retrofit label supplied, including the name of the installing Dealer.

Tear off the appropriate language section or sections.

Remove the backing from the self-adhesive label and affix to a prominent position on the inner wing, covering the existing R-12 information label where possible.

Remove, destroy or permanently deface all original labels referring to R-12 refrigerant.

Post-fitting Checks

Using a dedicated HFC R-134a electronic analyser, check for non-visible leaks around the system; gross leakage will be evident by the escape of oil.

Reconnect the battery.

From inside the vehicle, run the engine at idle speed for fifteen minutes with the air-conditioning controls set to manual, full cooling and high fan speed to establish the performance of the air-conditioning system.

Reset the vehicle radio security code and the time clock.

Remove the protective wing covers.

Close the driver side door and the bonnet.

JAGUAR SERIES III 5.3 LITRE V12 AIR-CONDITIONING R-134a RETROFIT

Applicability

Jaguar Series III V12 5.3 litre models in the VIN range: 300001 to 500000.

Note: Vehicles covered by this instruction are fitted with a Harrison compressor.

Pre-fitting Requirements

Open the driver side door and the bonnet.

Fit protective wing covers.

Reclaiming R-12 from the Air-conditioning System

Note: The reclamation of R-12 **must** be carried out in accordance with the instructions detailed in the operating manual provided with the charging station.

Position the R-12 air-conditioning charging station close to the vehicle.

Undo and remove the protective caps from the high and low pressure charging ports on the vehicle.

Position the R-12 air-conditioning charging station high and low pressure hoses to the vehicle.

Connect the low pressure hose (BLUE) to the vehicle low pressure charging port (1, Fig. 1).

Connect the high pressure hose (RED) to the vehicle high pressure charging port (2, Fig. 1).

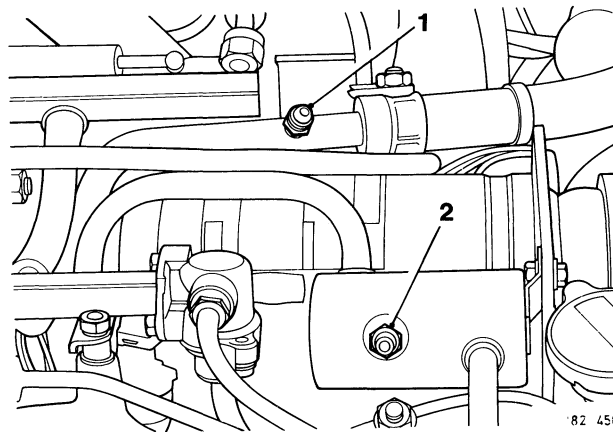

Fig. 1

From inside the vehicle, run the engine at idle speed for fifteen minutes with the air-conditioning controls set to manual, full cooling and high fan speed to establish the performance of the air-conditioning system. This operating condition also has the effect of collecting the majority of system mineral oil in the compressor.

Switch off the engine after fifteen minutes.

Disconnect the battery.

Switch the R-12 air-conditioning charging station to the recovery/reclaim mode.

Recover the R-12 refrigerant from the vehicle air-conditioning system.

Place suitable container under the charging station oil drain outlet and collect all oil recovered with the R-12 refrigerant during reclamation.

Isolate the R-12 air-conditioning charging station from the vehicle *in accordance with the instructions provided in the charging station operating manual.*

Removing the Air-conditioning System Compressor

Slacken the bolt securing the drive belt tensioning idler pulley carrier (1, Fig. 2) to the mounting bracket.

Slacken the bolt securing the adjusting rod to the idler pulley carrier (4, Fig. 2).

Undo the adjusting rod locknut (3, Fig. 2).

Note: Pivot the pulley in towards the engine to release tension on the drive belt.

Displace and reposition the compressor drive belt.

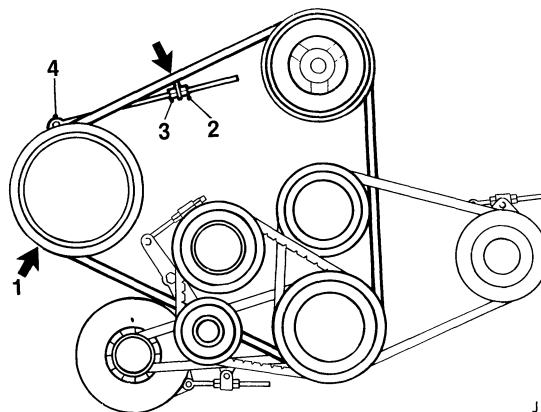

Fig. 2

Disconnect the compressor low pressure switch harness multi-plug (1, Fig. 3).

Disconnect the drive clutch coil multi-plug connector (2, Fig. 3)

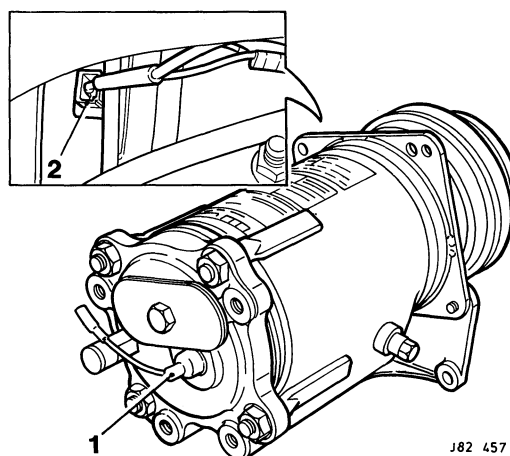

Fig. 3

Undo and remove the bolt securing the compressor muffler to the compressor forward mounting (1, Fig. 4).

Undo and remove the bolts securing the cruise control bellows mounting bracket.

Displace and reposition the cruise control bellows assembly.

Undo and remove the bolt (2, Fig. 4) securing the compressor hoses together with the cruise control bellows mounting bracket.

Displace the muffler and suction hose from the rear of the compressor.

Remove and discard the compressor O-ring seals.

Fit suitable blanking plugs to the open hoses to prevent the ingress of foreign material.

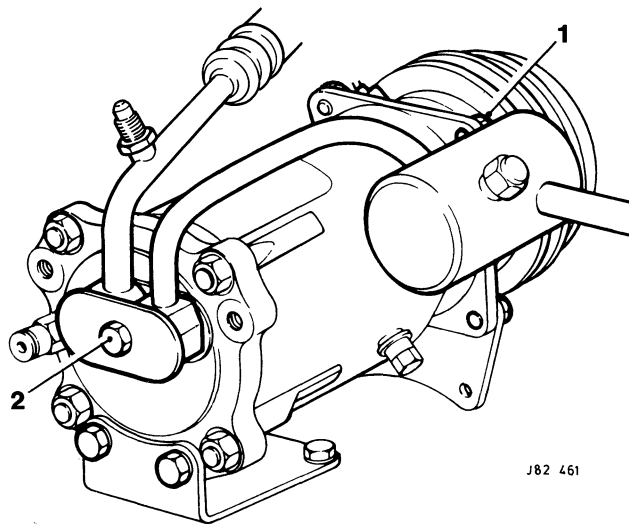

Fig. 4

Fit a blanking plate (1, Fig. 5) to the compressor.

Fit and tighten the bolt (2, Fig. 5) to secure the blanking plate to the compressor.

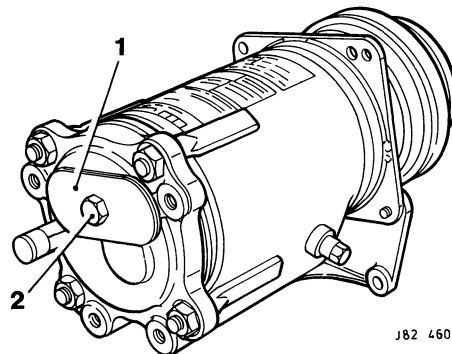

Fig. 5

Undo and remove the bolts (1, Fig. 6) securing the compressor to the rear mounting bracket.

Undo and remove the bolts (2, Fig. 6) securing the compressor to the front mounting bracket.

Displace and remove the compressor assembly and place on a clean workbench.

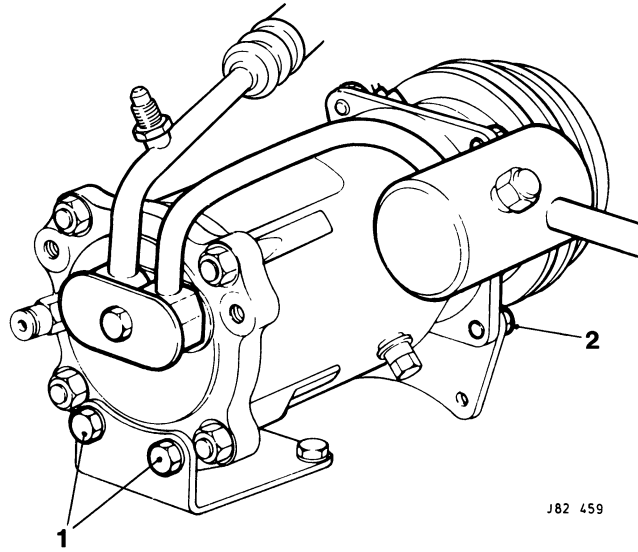

Fig. 6

Draining, Flushing and Recharging the Compressor

Place a suitable measuring container on the workbench.

Undo and remove the bolt securing the blanking plate to the compressor.

Displace and remove the blanking plate.

Undo and remove the compressor sump plug (1, Fig. 7).

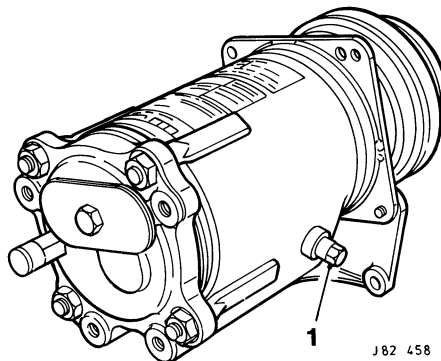

Fig. 7

Tip the compressor and drain compressor oil into a suitable container.

Undo the discharge hose muffler union nut.

Disconnect the muffler from the discharge hose.

Remove and discard the hose O-ring seal.

Fit a suitable blanking plug to the discharge hose.

Drain the oil from the muffler into a suitable container.

Fit suitable blanking plugs to the open ports in the muffler to prevent the ingress of foreign material.

Pour 100ml of Ester oil in a clean measuring vessel.

Pour the Ester oil from the measuring vessel into the compressor.

Manually work the oil around the compressor then drain and discard the oil from the compressor.

Recharging the Compressor

Pour 284ml of Ester oil into a clean measuring vessel.

Pour the Ester oil from the measuring vessel into the compressor.

Fit and fully tighten the compressor sump plug.

Installing the Air-conditioning System Compressor

Fit and align the compressor blanking plate.

Fit and tighten the bolt to secure the blanking plate to the compressor.

Fit and align the Ester-charged compressor to its mounting brackets.

Fit and fully tighten the bolts to secure the compressor to the front mounting bracket.

Fit and fully tighten the nuts to secure the compressor to the rear mounting bracket.

Connect the low pressure switch multi-plug connector to the low pressure switch at the rear of the compressor.

Undo and remove the bolt securing the compressor port blanking plate to the compressor.

Displace and remove the blanking plate from the compressor.

Fit new O-rings to the compressor.

Displace and remove the blanking plugs from the compressor muffler.

Fit and fully seat the compressor suction hose to the compressor.

Fit and align the muffler to the compressor.

Fit and tighten the nut and bolt to secure the muffler to the compressor forward mounting.

Fit and align the cruise control bellows mounting bracket assembly to the compressor discharge and suction hoses.

Fit and tighten the bolts to secure the cruise control mounting bracket.

Fit and tighten the compressor hose and muffler securing bolt

Reposition the cruise control bellows.

Tighten the bolt to secure the cruise control bellows to its mounting bracket.

Connect the clutch coil harness multi-plug.

Remove the plug from the discharge hose.

Fit a new O-ring seal to the discharge hose.

Connect the hose to the muffler.

Tighten the union nut to secure the hose to the muffler.

Fit and align the compressor drive belt to the compressor.

Tighten the adjusting rod adjustment locknut (3, Fig. 2) to achieve the correct tension on the compressor drive belt. Refer to the workshop manual for the correct tension figure.

Tighten the adjusting rod locknut (2, Fig. 2) to preserve drive belt setting.

Tighten the bolt to secure the adjusting rod to the idler pulley carrier.

Tighten the bolt to secure the idler pulley carrier to the mounting bracket pivot.

Removing the Existing Receiver-Drier Bottle

Undo the liquid line union nut at its connection on the receiver-drier bottle Fig. 8.

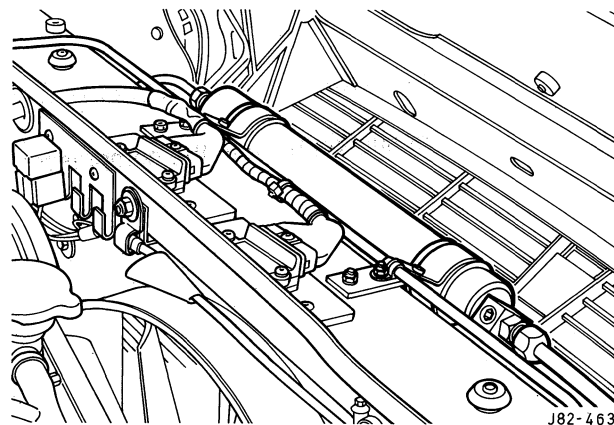

Fig. 8

Undo the condenser pipe union nut at its connection on the receiver-drier bottle.

Undo and remove the nuts securing the receiver-drier bottle top rail mounting brackets to the top rail.

Displace the bleed pipe securing clips from their studs.

Undo and remove the clamping nuts and bolts securing the receiver–drier into its top rail mounting brackets.

Displace and reposition the receiver–drier bottle top rail mounting brackets from the top rail.

Disconnect the liquid line.

Remove and discard the liquid line O–ring seal.

Disconnect the receiver–drier bottle from the condenser pipe.

Remove and discard the receiver–drier bottle pipe O–ring seal.

Displace and remove the receiver–drier bottle.

Fit suitable blanking plugs to the receiver–drier bottle and pipes.

Fitting a New R–134a Compatible Receiver–Drier Bottle

Place a new receiver–drier bottle on the workbench.

Remove the backing paper from the receiver–drier bottle mounting rubbers.

Fit and align the mounting rubbers to the new receiver–drier bottle.

Fit and align the top rail mounting brackets to the receiver–drier, ensuring that the sight glass is facing upwards.

Undo and remove the receiver–drier bottle protective caps.

Remove the blanking plugs from the pipes.

Fit new O–rings seals to the pipes.

Place the receiver–drier bottle to the vehicle.

Connect pipes to the receiver–drier bottle.

Fit but do not tighten the pipe union nuts.

Position the receiver–drier bottle mounting brackets to the top rail.

Position the bleed pipe mounting clips to the top rail studs.

Fit and tighten the receiver–drier bottle mounting bracket securing nuts.

Fit and tighten the mounting bracket clamping nuts and bolts.

Fully tighten union nuts to secure the pipes to the receiver–drier bottle.

Fitting R-134a Adaptors to the R-12 Fittings

The charge port service adaptor threads are coated with thread-locking fluid. Ensure that the threads of the existing R-12 charging valves are cleaned before fitting the new adaptors.

Fit and tighten a straight R-134a refrigerant high pressure adaptor (RED) (Fig. 9) to the R-12 high pressure connector on the discharge hose.

Note: At 91MY, undo and remove the Schrader valve from the R-12 high pressure connector on the discharge hose and fit an R-134a refrigerant high pressure elbow adaptor to the R-12 connector. The Schrader valve must be removed to enable the R-134a elbow connector to function properly.

Fit and tighten a straight R-134a refrigerant low pressure adaptor (BLUE) (Fig. 9) to the R-12 low pressure connector on the suction hose.

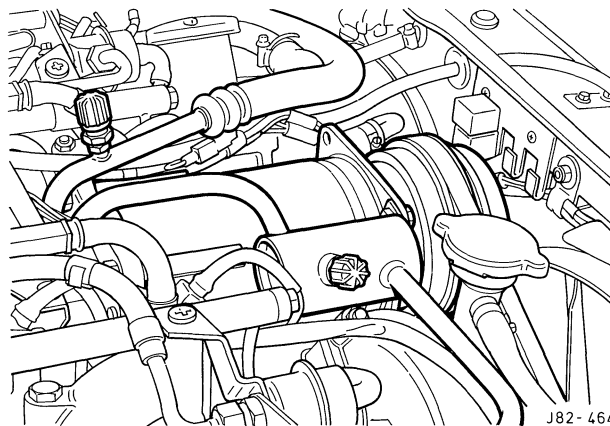

Fig. 9

Charging the Vehicle Air-conditioning System with R-134a Refrigerant

Note: Charging of the air-conditioning charging station and the vehicles air-conditioning system **must** be carried out in accordance with the instructions detailed in the operating manual provided with the charging station.

Position the R-134a air-conditioning charging station close to the vehicle and R-134a gas supply cylinder.

Charge the R-134a air-conditioning charging station with 1150 grammes of R-134a refrigerant from a gas supply cylinder.

Disconnect the air-conditioning charging station from the gas supply cylinder.

Undo and remove the protective caps from the high and low pressure charging ports on the vehicle.

Position the R-134a air-conditioning charging station high and low pressure hoses to the vehicle.

Connect the high pressure hose (RED) to the vehicle high pressure charging port (Fig. 9).

Connect the low pressure hose (BLUE) to the vehicle low pressure charging port (Fig. 9).

Evacuate the system in accordance with the charging station procedures.

Switch the R143a air-conditioning charging station to the charging mode.

Charge the vehicle air-conditioning system with 1150 grammes of R-134a refrigerant.

Disconnect the charging station high and low pressure hoses from the charging port adaptors on the vehicle.

Fit protective caps to the low and high pressure adaptors on the vehicle; RED cap for the high pressure adaptor and the BLUE cap for the low pressure adaptor.

Retrofit Warning Labels

Using a suitable oil-resistant marker, fill in all retrofit details on the retrofit label supplied, including the name of the installing Dealer.

Tear off the appropriate language section or sections.

Remove the backing from the self-adhesive label and affix to a prominent position on the inner wing, covering the existing R-12 information label where possible.

Remove, destroy or permanently deface all original labels referring to R-12 refrigerant.

Post-fitting Checks

Using a dedicated HFC R-134a electronic analyser, check for non-visible leaks around the system; gross leakage will be evident by the escape of oil.

Reconnect the battery.

From inside the vehicle, run the engine at idle speed for fifteen minutes with the air-conditioning controls set to manual, full cooling and high fan speed to establish the performance of the air-conditioning system.

Reset the vehicle radio security code and the time clock.

Remove the protective wing covers.

Close the driver side door and the bonnet.