

POWER HYDRAULIC SYSTEM

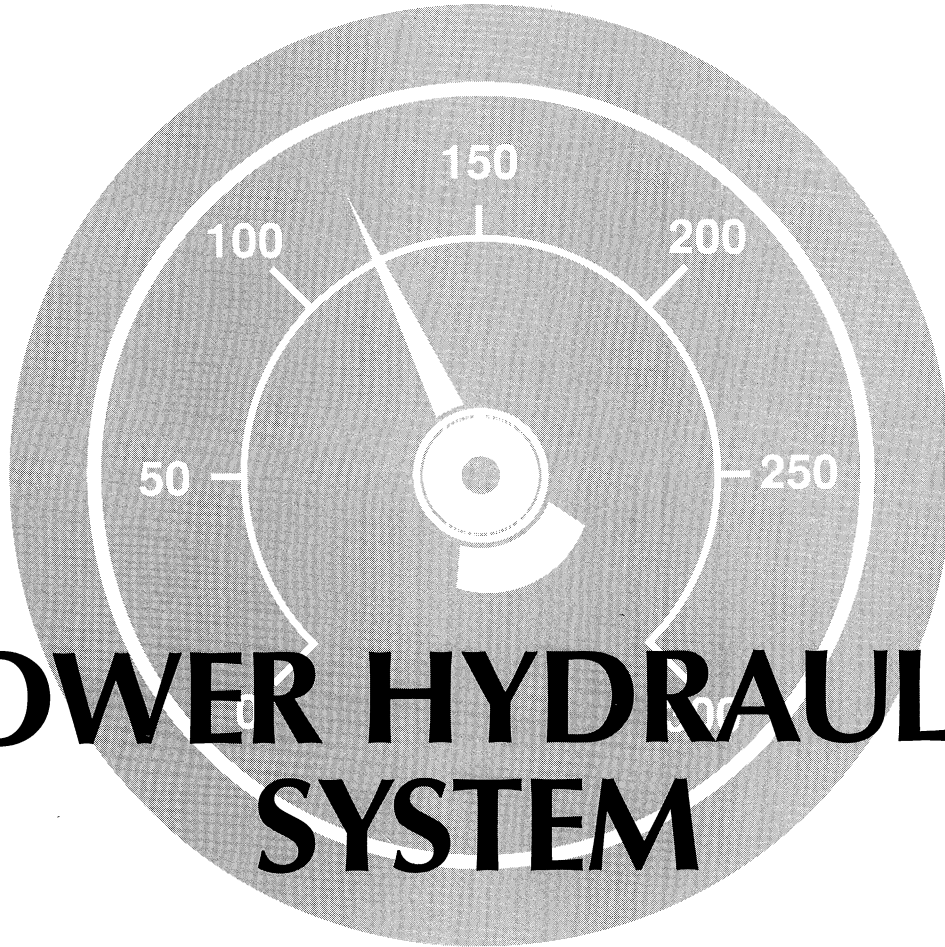



POWER HYDRAULIC SYSTEM

Publication number S-73

© 1992 Jaguar Cars Inc.

All rights reserved. All material contained herein is based on the latest information available at the time of publication. The right is reserved to make changes at any time without notice.



CONTENTS

INTRODUCTION	1
SYSTEMS DESCRIPTION	2 – 13
Overview	2 – 4
Valve Block	5 – 7
Wiring Diagrams	8 – 9
System Operation (1988 – 89 MY)	10 – 11
System Operation (1990 MY ON)	11
Components	12 – 13
SERVICE	14 – 35
System Revisions and Repair Policies	14 – 16
System Fault Symptoms	17
System Testing	18 – 30
Repair Procedures	31 – 35
PRESSURE CONVERSION CHART	36

Service information pertaining to the power hydraulic system used in XJ6 (1988 – 89 MY) and Sedan Range (1990 MY ON) vehicles is contained in various publications and Technical Bulletins. This FOCUS booklet is designed to be the source document for all Power Hydraulic descriptive, diagnostic and repair information. The information contained herein is the most current available at the time of publication and supersedes all previous publications and Technical Bulletins.

All pressures are stated and read in bar. Refer to the Pressure Conversion Chart (page 36) for bar to psi conversion.

 **WARNING: THE OPERATIONS AND PROCEDURES CONTAINED IN THIS PUBLICATION ARE INTENDED FOR USE BY PROFESSIONAL TECHNICIANS WITH KNOWLEDGE OF JAGUAR VEHICLE SYSTEMS. ALL NECESSARY SAFETY PRECAUTIONS MUST BE TAKEN WHEN SERVICING OR TESTING SYSTEMS THAT HAVE THE POTENTIAL FOR CAUSING BODILY INJURY OR DEATH.**



OVERVIEW

Sedan Range vehicles use a central engine driven power hydraulic system. In model years 1988 and 89, this system supplies hydraulic pressure for rear suspension ride leveling and brake power boost. In model years 1990 ON (except XJ6), the system supplies hydraulic pressure for the rear suspension ride leveling only. The basic design and operation of the central components of the system (pump and valve block) remain the same regardless of the model year.

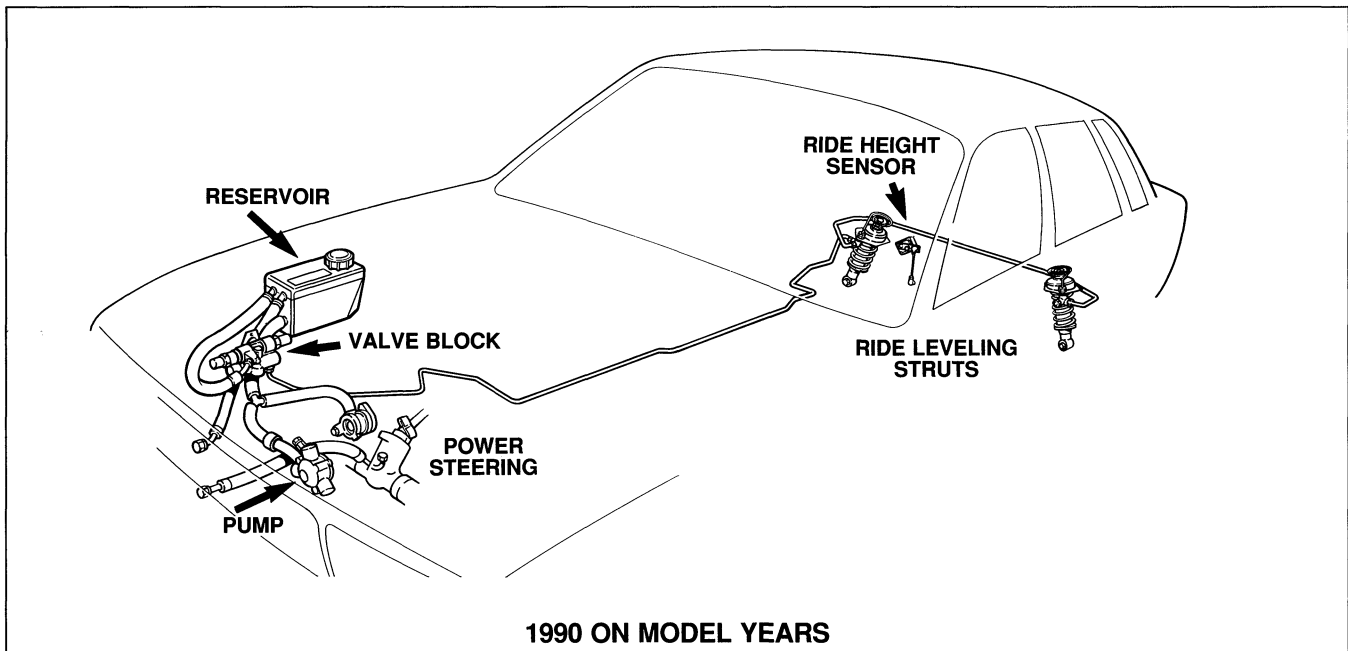
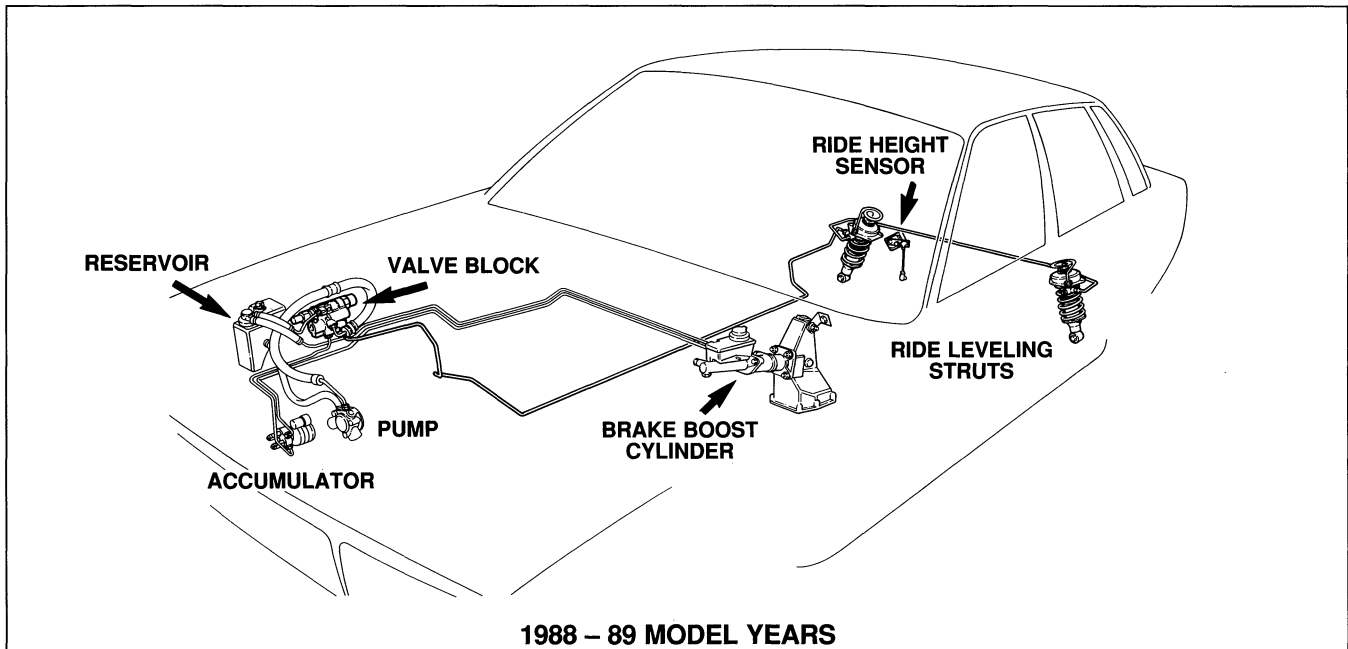

1988 – 89 Model Years

The power hydraulic system provides brake system power boost and rear suspension ride leveling. The power hydraulic system is completely separate from the brake hydraulic system. The two systems use different hydraulic fluid: Hydraulic System Mineral Oil (HSMO) in the power hydraulic system; DOT 4 brake fluid in the braking system.

Hydraulic Pressure Hydraulic pressure is supplied independent of engine speed, load or temperature. The reservoir supplies oil to the engine-driven pump, which in turn delivers high pressure oil to the valve block. The valve block has three functions using solenoid activated valves: brake boost charge, rear suspension up and rear suspension down.

Brake Power Boost The brake boost portion of the system incorporates an accumulator. Charging of the accumulator takes priority over ride leveling to ensure that a reserve capacity of pressurized hydraulic oil exists continually. The system has a reserve capacity to provide fully-assisted brake applications. Two pressure switches are incorporated into the accumulator assembly. The charge switch activates the valve block charge valve. The low pressure warning switch provides a low pressure warning signal to the VCM (vehicle condition monitor) and disables the operation of the up solenoid until a minimum pressure is re-established in the accumulator.

Rear Suspension Ride Leveling The rear suspension ride leveling portion of the system operates automatically to maintain a minimum ride height. The ride leveling circuit makes trim adjustments to compensate for extreme load (weight) changes over the rear axle. The system does not compensate for minor load changes, or for cornering loads and loads imposed by undulating road conditions.

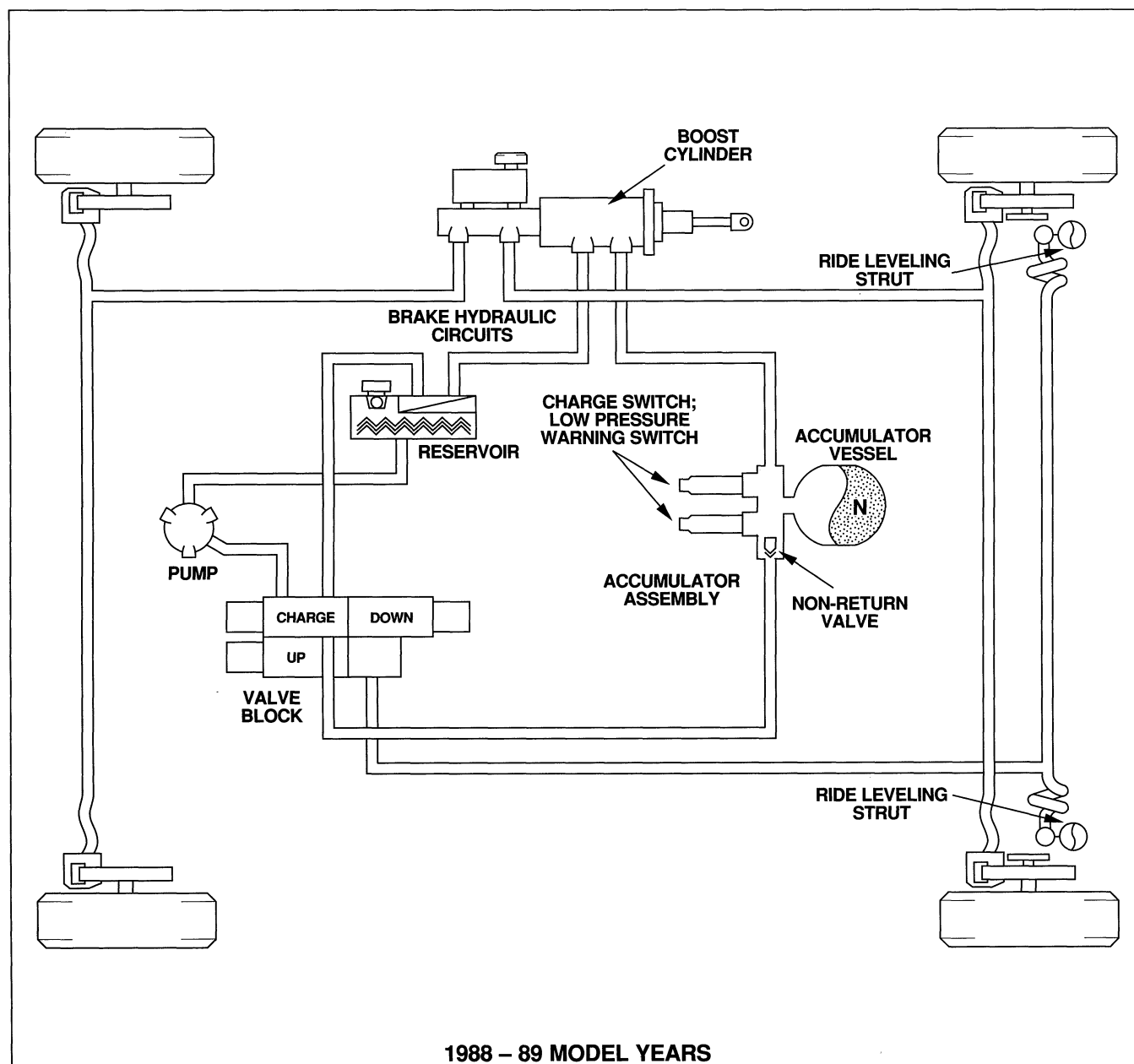

CAUTION: THE RIDE LEVELING SYSTEM WILL ALLOW THE VEHICLE TO BE OVERLOADED WITHOUT A PERCEPTIBLE CHANGE IN TRIM HEIGHT. ENSURE THAT THE SPECIFIED VEHICLE GROSS WEIGHT IS NOT EXCEEDED WHEN LOADING.



OVERVIEW (continued)

1990 ON Model Years (except XJ6)

The Sedan Range vehicles with ride leveling use the central power hydraulic system to provide ride leveling only. This system shares its reservoir with the power steering system and both use Hydraulic System Mineral Oil (HSMO).

Vehicles up to VIN 653345 The valve block charge port to the previous brake boost accumulator is blocked off. The charge and up valves operate simultaneously to pressurize the ride leveling struts.

Vehicles VIN 653345 ON The valve block body remains the same with the charge port to the previous brake boost accumulator blocked off. Only the charge and down valves are installed. The up valve is replaced by a blanking plug.

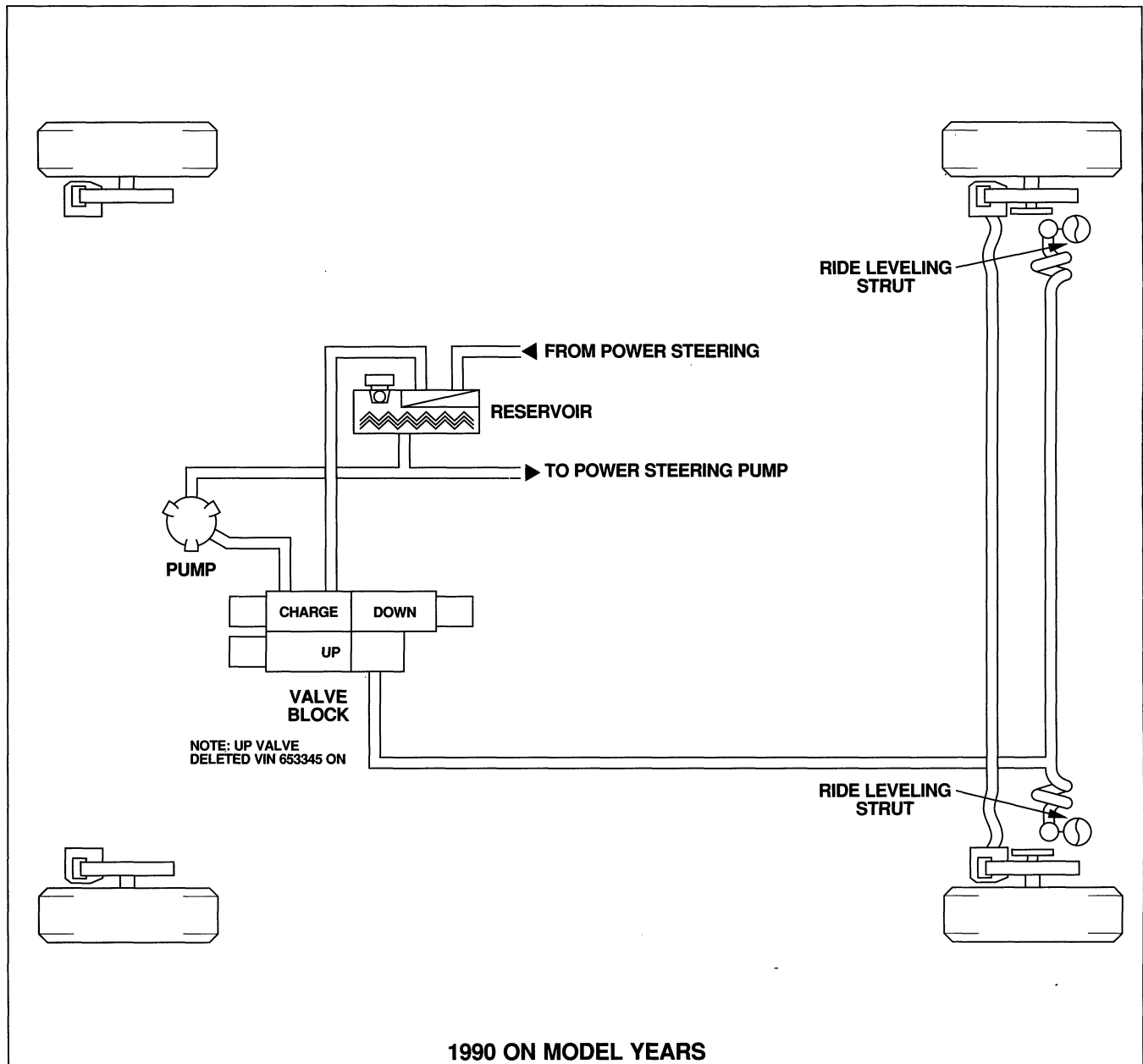

CAUTION: THE RIDE LEVELING SYSTEM WILL ALLOW THE VEHICLE TO BE OVERLOADED WITHOUT A PERCEPTIBLE CHANGE IN TRIM HEIGHT. ENSURE THAT THE SPECIFIED VEHICLE GROSS WEIGHT IS NOT EXCEEDED WHEN LOADING.

1988 – 89 Model Years

The operation of the three valve block solenoid activated valves is controlled by the charge switch and the ride height sensor. The charge valve is normally open and the up and down valves are normally closed. The charge valve is activated by both the charge switch and the ride height sensor. The up valve is activated by the ride height sensor via the suspension relay. The down valve is activated directly by the ride height sensor. Refer to the wiring diagram on page 8.

1990 ON Model Years (vehicles up to VIN 653345)

The operation of the three valve block solenoid activated valves is controlled by the ride height sensor only. Both the charge and up valve solenoids are activated by the ride height sensor via the suspension relay. The down valve solenoid is activated directly by the ride height sensor. Refer to the wiring diagram on page 9.

Vehicles VIN 653345 ON

The up valve is deleted and replaced by a blanking plug. The operation of the charge and down valves remains the same as described above (1990 ON Model Years).

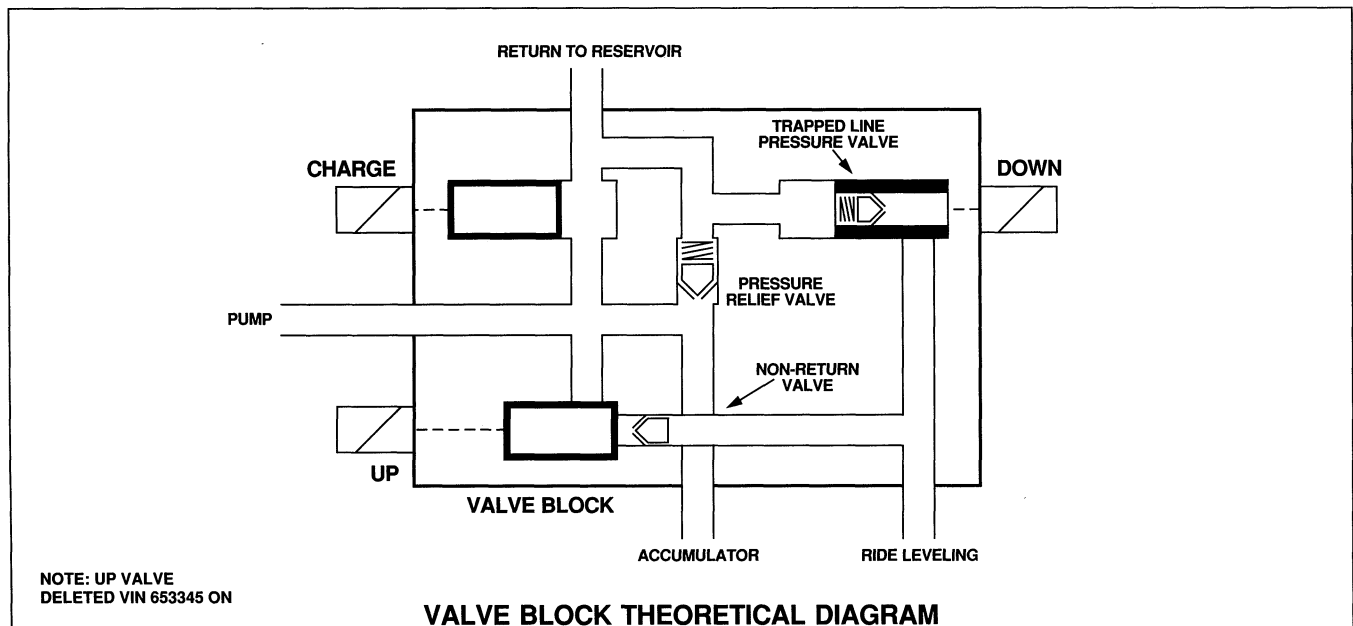
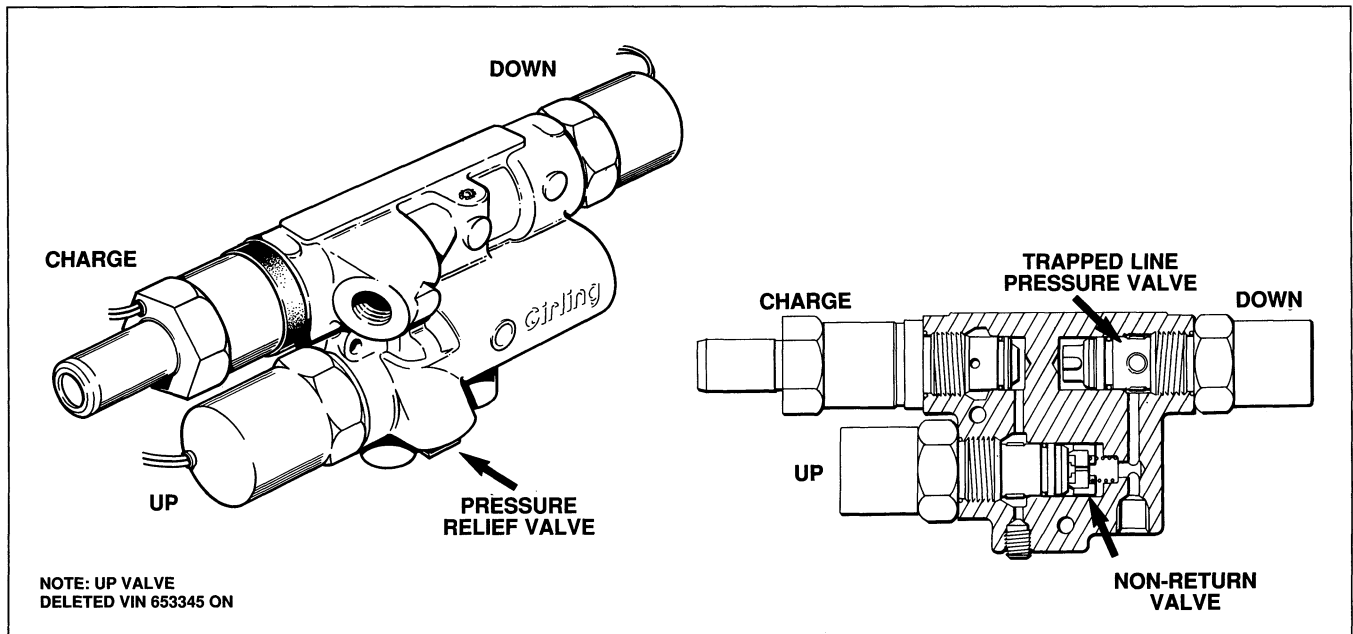



VALVE BLOCK (continued)

No Charge / No Ride Leveling operation

When there is no call for accumulator charge pressure or ride leveling pressure, the charge valve is open, directing oil flow back to the reservoir. The up and down valves are closed to the ride leveling circuit.

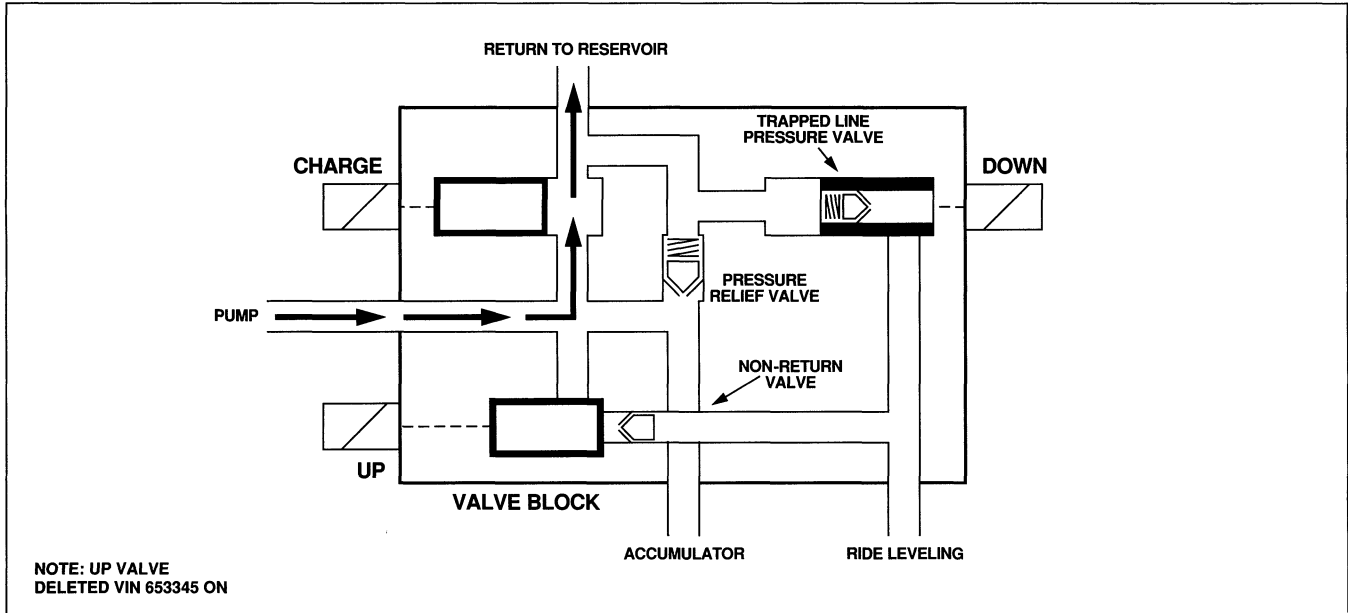

Accumulator Charge operation (1988 - 89 MY only)

When the charge solenoid is activated, it closes the charge valve. Pressurized oil is applied to the brake boost circuit to recharge the accumulator. The pressure relief valve in the valve block protects the system from over pressurization.

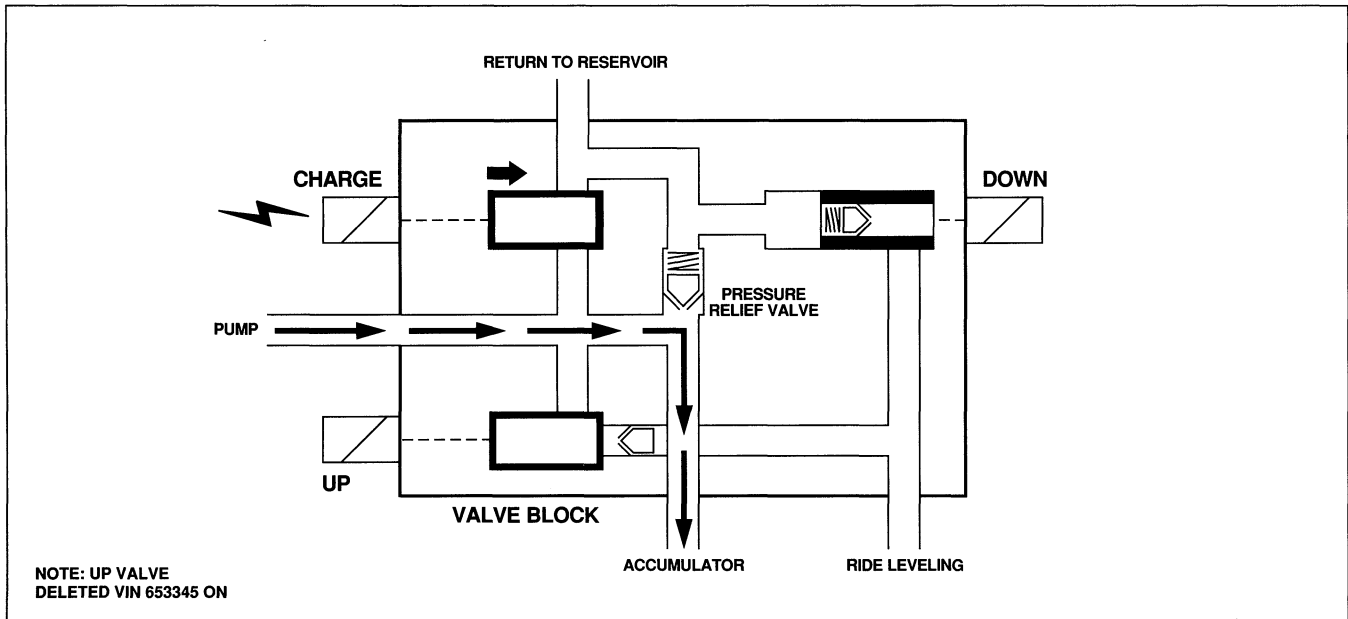

Ride Level Up operation

When ride leveling up pressure is required, the charge and up valve solenoids are activated to close the charge valve and open the up valve (vehicles up to VIN 653345). In vehicles VIN 653345 ON, the charge valve solenoid is activated to close the charge valve. Pressurized oil is directed to the ride leveling circuit to raise the rear of the vehicle. Pressurized oil is also applied to the brake boost circuit (1988 – 89 MY vehicles). When the ride leveling compensation is achieved, the up valve closes and the charge valve opens directing oil from the pump to the reservoir.

The non-return valve under the up valve (or blanking plug) prevents return flow from the rear suspension if the charge pressure drops below the rear suspension pressure. The pressure relief valve prevents over-pressurization in the event of a gross overloading of the vehicle.

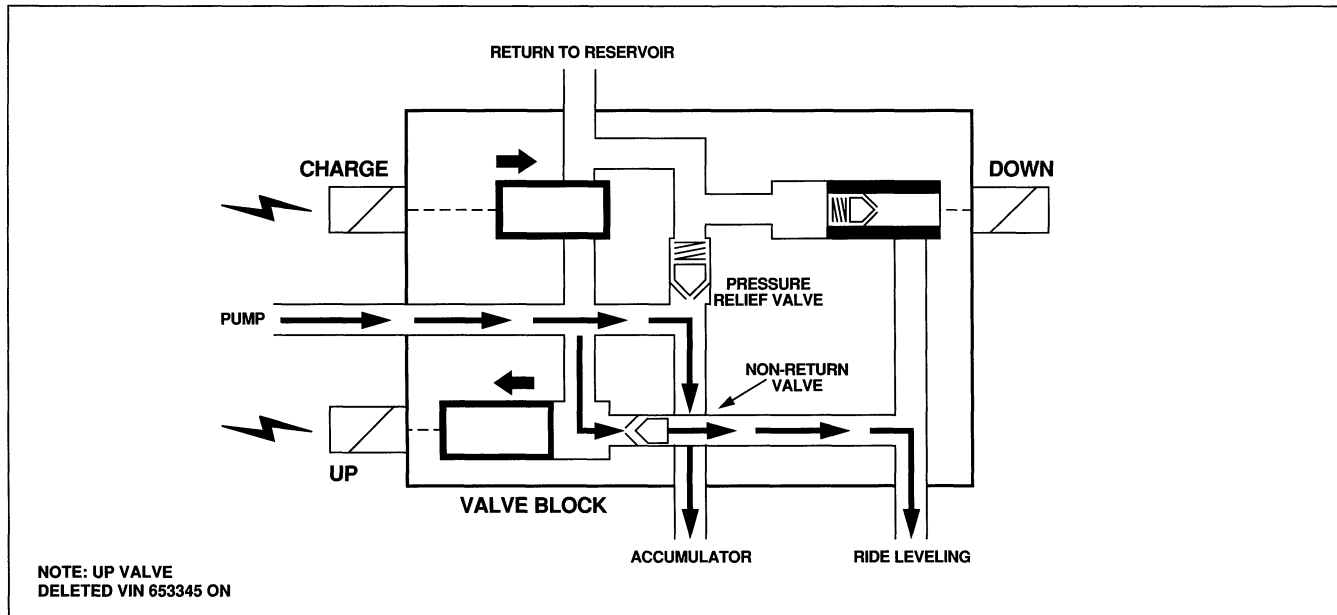

Ride Level Down operation

When ride leveling down is required, the down valve solenoid is activated to open the down valve allowing oil return to the reservoir to lower the rear of the vehicle. The trapped line pressure valve located within the down valve maintains a minimum pressure in the rear suspension.

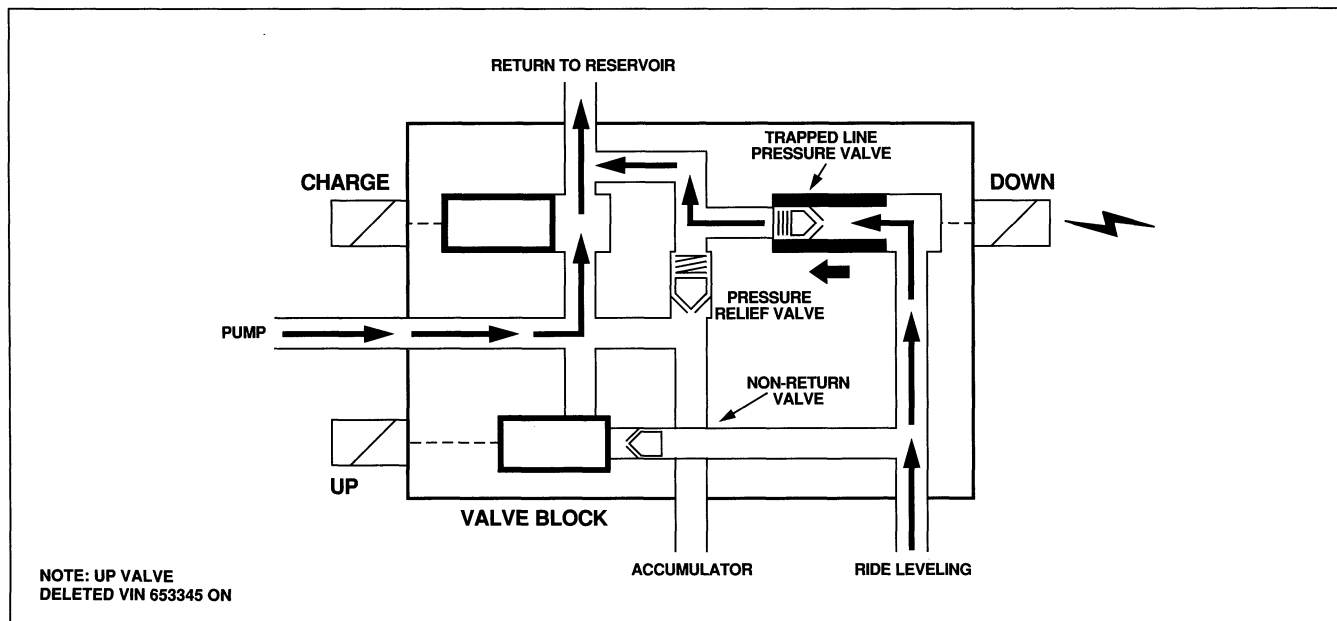

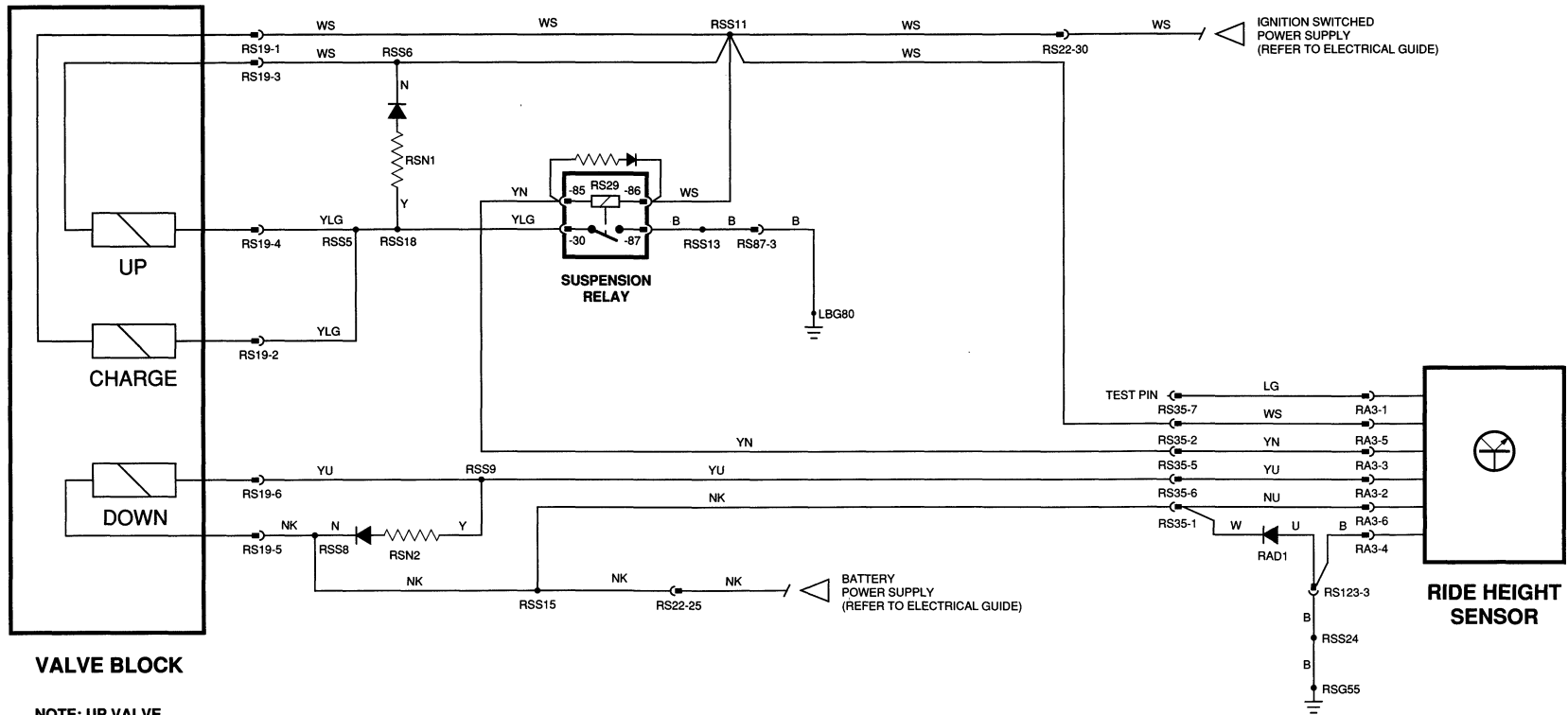

VALVE BLOCK

NOTE: UP VALVE
DELETED VIN 653345 ON

CONNECTOR DATA

CODE	DESCRIPTION	LOCATION / INTERFACE
RA3	3-WAY PLUG (BLACK)	REAR BRAKE CALIPER / BRAKE PAD
RS19	6-WAY PM4 (YELLOW)	ENGINE COMPARTMENT / RIGHT FRONT
RS22	36-WAY PMHD (BLACK)	RIGHT 'A' POST, UNDER DASH PANEL / LB HARNESS
RS29	RELAY BASE (BLUE)	TRUNK, RIGHT FRONT / SUSPENSION RELAY
RS35	8-WAY PM4 (BLACK)	TRUNK BULKHEAD TRIM / RA HARNESS
RS87	6-WAY PM4 (BLACK)	RIGHT 'A' POST, UNDER DASH PANEL / LB HARNESS
RS123	3-WAY ECONOSEAL (BLACK)	TRUNK, RIGHT FRONT CORNER / RIDE HEIGHT SENSOR GROUND





SYSTEM OPERATION: 1988 – 89 MODEL YEARS

Brake boost — CHARGE

System charging occurs if the accumulator pressure falls below 83 bar. At 83 bar, the charge switch closes completing the charge valve solenoid circuit to ground and closing the charge valve. Pressurized hydraulic oil is applied to the boost circuit as described earlier. The system continues to charge until the accumulator pressure reaches 100 bar at which time the charge switch opens directing pressurized oil from the pump to the reservoir.

If the accumulator pressure falls below 54 bar (at engine start or during operation), the low pressure warning switch opens with two results: the VCM low pressure warning activates and the suspension relay ground circuit from pin 87 is interrupted. Interrupting the relay ground circuit disables the up valve circuit thereby prioritizing brake boost. The low pressure warning switch closes when the accumulator pressure reaches 69 bar reversing the above conditions.

Ride leveling — UP COMPENSATION

If the accumulator pressure falls below 54 bar, brake boost is prioritized as described above. Once the low pressure switch opens at 54 bar, no up compensation occurs until the accumulator pressure reaches 69 bar and the switch closes. If the accumulator pressure is 54 bar or above, or 69 bar or above (as applicable), up compensation can occur.

NOTE: Up compensation will not occur until the vehicle load causes the rear suspension to lower approximately 2 1/4 inches.

When the ride height sensor detects a requirement for up compensation, a 20-second delay occurs before the sensor completes the suspension relay solenoid circuit to activate the relay. When activated, the relay completes the charge and up valve solenoid circuits simultaneously. The charge valve closes and the up valve opens applying hydraulic pressure to the rear suspension struts. Additionally, hydraulic pressure is applied to the accumulator. The non-return valve in the accumulator maintains pressure in the brake boost circuit. As the normal ride height is reached, the sensor switches off the suspension relay opening the charge valve and closing the up valve. Hydraulic pressure from the pump is returned to the reservoir.

The non-return valve under the up valve prevents return flow from the rear suspension if the pump pressure drops below the rear suspension pressure while the up valve is open.

The valve block pressure relief valve allows return to the reservoir at 120 – 155 bar preventing over pressurization in the event of gross overloading of the vehicle.

The 20-second sensor output delay prevents the system from reacting to suspension loads imposed by cornering or bumpy roads.

Ride leveling — DOWN COMPENSATION

When the ride height sensor detects a requirement for down compensation, a 20-second delay occurs before the sensor completes the down valve solenoid circuit to open the down valve. When open, the down valve allows oil to return to the reservoir thereby lowering the rear of the vehicle. As the normal ride height is reached, the sensor switches off the down solenoid closing the down valve.

The trapped line pressure valve within the down valve maintains a minimum pressure of 28 bar in the ride leveling circuit. This "trapped line pressure" (minimum pressure) prevents damage to the suspension struts caused by too little hydraulic pressure. A revised ride height sensor incorporating a momentary pressure cycle was introduced at VIN 617978. Each time the engine is started, the ride leveling circuit is pressurized for a few seconds, preventing the gradual loss of "trapped line pressure". This action ensures that adequate hydraulic pressure is maintained in the ride leveling struts. Refer to page 15. If the ride height sensor outputs a down signal, the 28 bar minimum pressure prevents further suspension down travel and no down travel is detected. The sensor cancels the output after approximately 5 minutes.

The 20-second sensor output delay prevents the system from reacting to suspension loads imposed by cornering or bumpy roads.

Brake boost – OPERATION

Accumulator pressure is applied to the brake boost cylinder at all times and produces a pedal return force of 20 pounds to move the boost piston to the full return position.

When the brakes are applied, the pressurized oil from the accumulator is fed to the servo chamber providing pedal assist. A reaction disc within the boost cylinder ensures that the degree of boost is proportional to the application effort from the driver (up to the limit of boost).

When the brakes are released, the servo hydraulic pressure is vented to the reservoir. The hydraulic oil returns to the reservoir. The boost piston returns to the full return position.

Ride leveling — UP COMPENSATION (Vehicles up to VIN 653345)

NOTE: Up compensation will not occur until the vehicle load causes the rear suspension to lower approximately 2 1/4 inches.

When the ride height sensor detects a requirement for up compensation, a 20-second delay occurs before the sensor completes the suspension relay solenoid circuit to activate the relay. When activated, the relay completes the charge and up valve solenoid circuits simultaneously. The charge valve closes and the up valve opens applying hydraulic pressure to the rear suspension struts. As the normal ride height is reached, the sensor switches off the suspension relay opening the charge valve and closing the up valve. Hydraulic pressure from the pump is returned to the reservoir.

The non-return valve under the up valve prevents return flow from the rear suspension if the pump pressure drops below the rear suspension pressure.

The valve block pressure relief valve allows return to the reservoir at 120 – 155 bar preventing over pressurization in the event of gross overloading of the vehicle.

The 20-second sensor output delay prevents the system from reacting to suspension loads imposed by cornering or bumpy roads.

Ride leveling — UP COMPENSATION (Vehicles VIN 653345 ON)

NOTE: Up compensation will not occur until the vehicle load causes the rear suspension to lower approximately 2 1/4 inches.

When the ride height sensor detects a requirement for up compensation, a 20-second delay occurs before the sensor completes the suspension relay solenoid circuit to activate the relay. When activated, the relay completes the charge valve solenoid circuit. The charge valve closes, applying hydraulic pressure to the rear suspension struts. As the normal ride height is reached, the sensor switches off the suspension relay opening the charge valve. Hydraulic pressure from the pump is returned to the reservoir.

The non-return valve under the up valve blanking plug prevents return flow from the rear suspension.

The valve block pressure relief valve allows return to the reservoir at 120 – 155 bar preventing over pressurization in the event of gross overloading of the vehicle.

The 20-second sensor output delay prevents the system from reacting to suspension loads imposed by cornering or bumpy roads.

Ride leveling — DOWN COMPENSATION

When the ride height sensor detects a requirement for down compensation, a 20-second delay occurs before the sensor completes the down valve solenoid circuit to open the down valve. When open, the down valve allows oil to return to the reservoir thereby lowering the rear of the vehicle. As the normal ride height is reached, the sensor switches off the down solenoid closing the down valve.

The trapped line pressure valve within the down valve maintains a minimum pressure of 28 bar in the ride leveling circuit. This “trapped line pressure” (minimum pressure) prevents damage to the suspension struts caused by too little hydraulic pressure. A revised ride height sensor incorporating a momentary pressure cycle was introduced at VIN 617978. Each time the engine is started, the ride leveling circuit is pressurized for a few seconds, preventing the gradual loss of “trapped line pressure”. This action ensures that adequate hydraulic pressure is maintained in the ride leveling struts. Refer to page 15. If the ride height sensor outputs a down signal, the 28 bar minimum pressure prevents further suspension down travel and no down travel is detected. The sensor cancels the output after approximately 5 minutes.

The 20-second sensor output delay prevents the system from reacting to suspension loads imposed by cornering or bumpy roads.

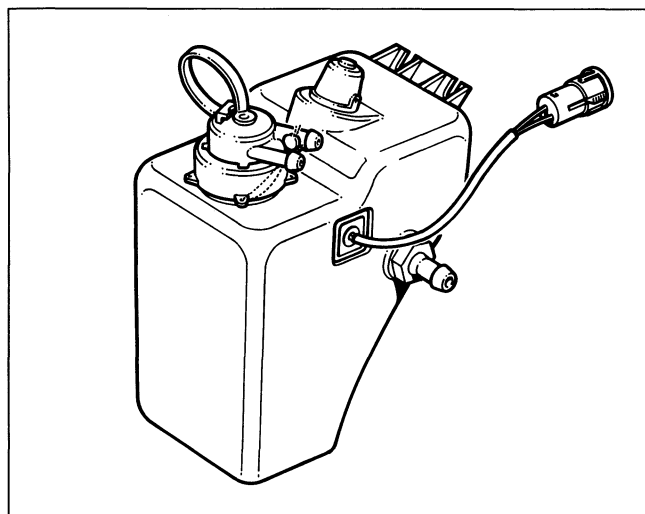

Reservoir (1988 – 89 MY)

The reservoir incorporates a visual level indicator plus a level sensor to signal the VCM (vehicle condition monitor). The reservoir can only be filled with HSMO from a container with a unique connector.

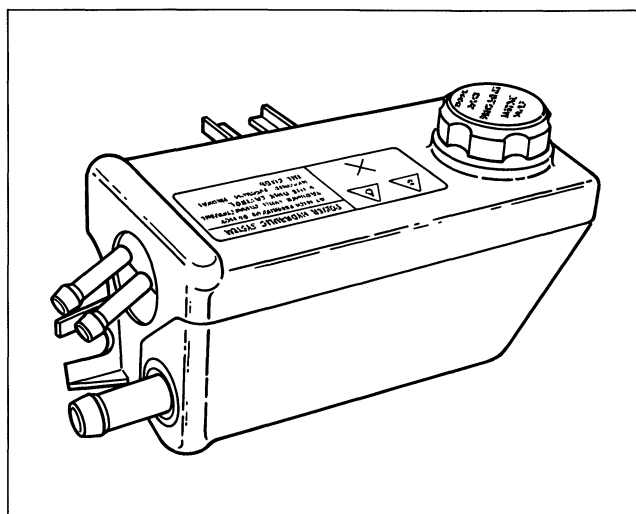

Reservoir (1990 MY ON)

The reservoir serves as the reservoir for the both the power hydraulic and power steering systems. Both systems use HSMO. The fill cap incorporates a dip stick for checking the fill level.

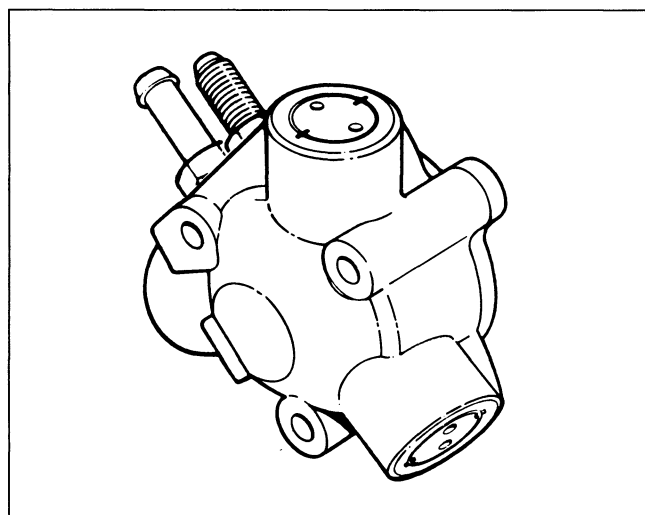

Pump

The three cylinder radial hydraulic pump turns at $\frac{3}{4}$ engine speed and is driven directly by the engine from the intermediate shaft drive pad. A coupling is used to connect the pump to the drive.

PUMP OUTPUT

0.153 gallons (0.7 litres) per minute
@ 600 rpm (pump speed)

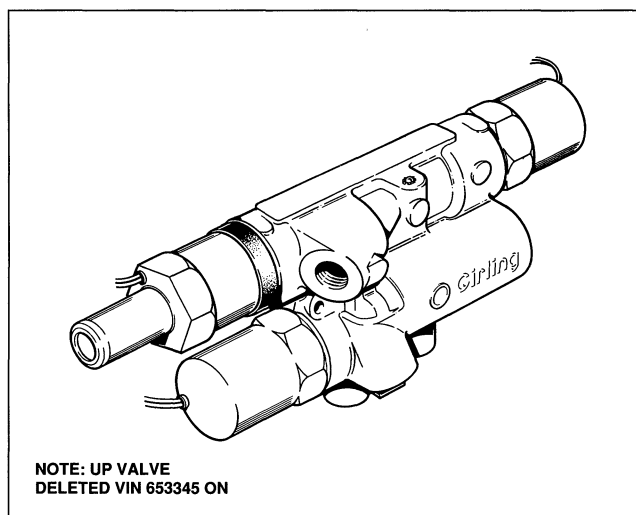

NOTE: UP VALVE
DELETED VIN 653345 ON

Valve block

The valve block contains the solenoid activated valves that are used to direct oil as necessary. Additionally, the valve block contains a pressure relief valve, a non-return valve and a trapped line pressure valve. The function of all the components is described previously.

PRESSURE RELIEF VALVE SPECIFICATION

Early valve	120 – 140 bar
Later valve	135 – 155 bar

TRAPPED LINE PRESSURE VALVE SPECIFICATION

28 – 45 bar

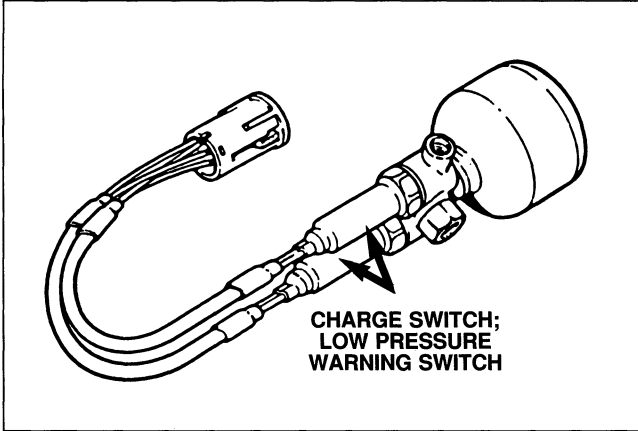

Accumulator (1988 – 89 MY)

The accumulator has a nitrogen charged chamber separated from the pressurized hydraulic oil by a diaphragm. The pressurized nitrogen stores system pressure and maintains boost pressure when the pump is inoperative or if a failure occurs. A non-return valve prevents return flow and maintains pressure on the accumulator side of the system. Two pressure switches are mounted on the accumulator base.

CHARGE SWITCH SPECIFICATION

OPEN (no system charge)	100 bar
CLOSE (system charge)	83 bar

LOW PRESSURE WARNING SWITCH SPECIFICATION

OPEN (VCM warning on; UP disabled)	54 bar
CLOSE (VCM warning off; UP enabled)	69 bar

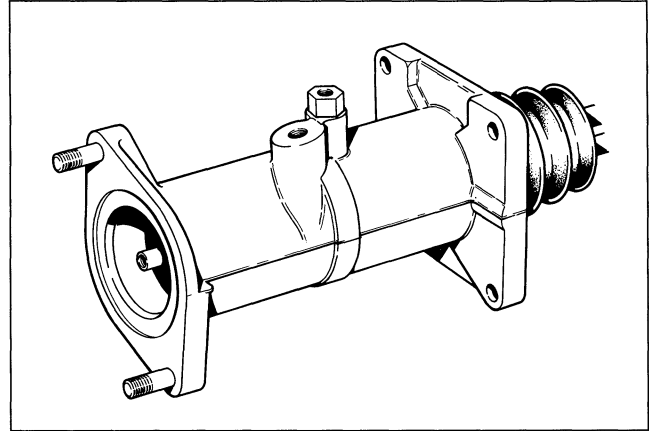

Brake boost cylinder (1988 – 89 MY)

The brake boost cylinder is activated by the brake pedal and converts hydraulic pressure supplied from the power hydraulic system into brake boost pressure. The degree of boost is proportional to the application effort from the driver.

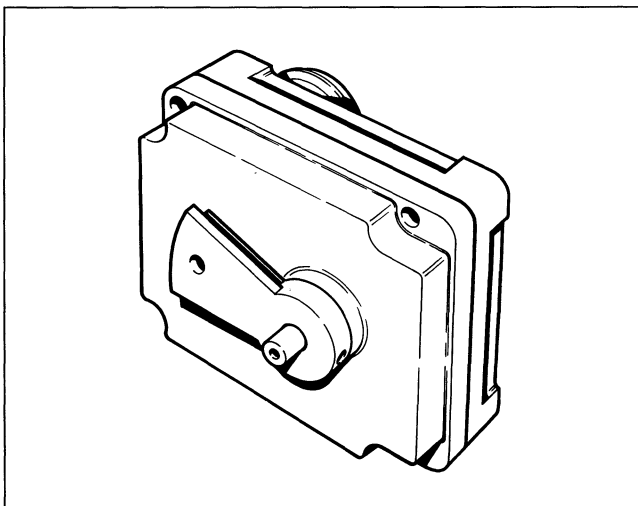

Ride height sensor

The ride height sensor incorporates a LED (light emitting diode) height sensing mechanism and an electronic control module. The unit incorporates the logic necessary for providing the 20-second delay before activating the up or down solenoid valves. Later sensors incorporate a charge replenishment cycle. (Refer to page 15.)

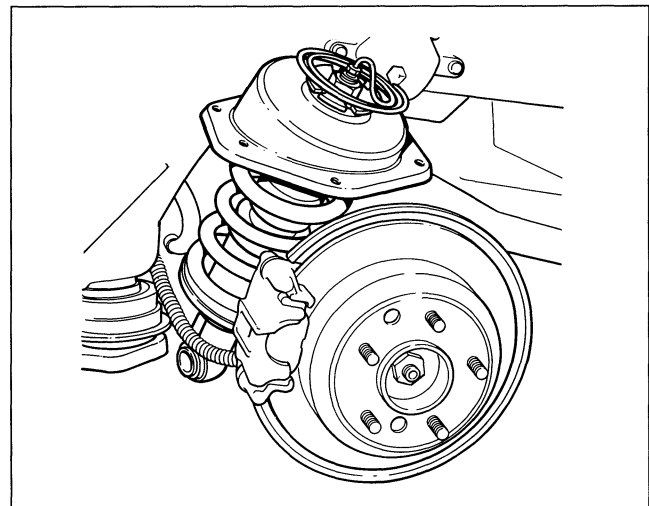

Ride leveling strut

The ride leveling provision is incorporated into the rear strut units.

SYSTEM REVISIONS AND REPAIR POLICIES

ACCUMULATOR; CHARGE SWITCH; LOW PRESSURE WARNING SWITCH

New charge and low pressure switches were introduced at VIN 576391 to eliminate the possibility of hydraulic oil leakage from the switch seals. The revised switches incorporate nitrile rubber "quad" seals and are identified by either a pink sleeve or green end-wrap around the switch wires. Only the revised switches are supplied as service parts.

Interchangeability All components are replaceable.

Part number(s) Accumulator vessel — JLM 10546; Accumulator base — JLM 10779; Charge switch — JLM 1526; Low pressure warning switch — JLM 1563

Repair policy If the accumulator vessel is defective, replace the vessel only. If the switch(es) are defective, replace the switch(es) only.

Service procedure Pages 34 – 35, this publication.

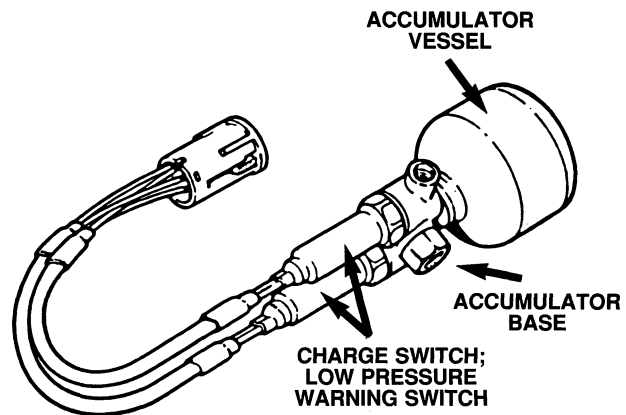

VALVE BLOCK — DOWN VALVE; CHARGE VALVE

New down and charge valves were introduced at VIN 598351. The down valve was redesigned to eliminate the possibility of unusual noise from the valve block during down leveling. The charge valve was redesigned to eliminate the possibility of unusual noise during the charge cycle.

Interchangeability The valves are exact replacements for the early valves.

Part number(s) Down valve — CBC 9700; Charge valve — CBC 9701

Repair policy Do not replace the valve block assembly; replace only the valve(s) found defective.

Service procedure Pages 31 – 32, this publication.

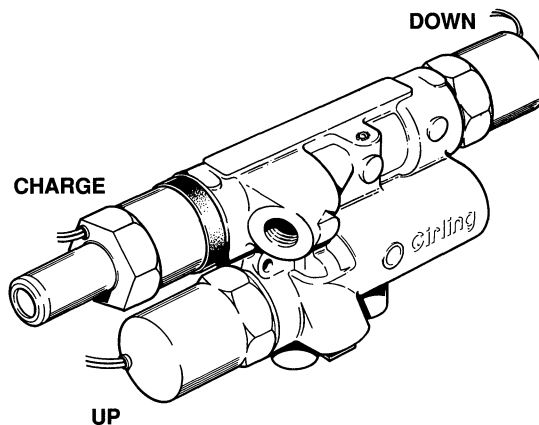

RESERVOIR (1990 MY)

A new reservoir incorporating a revised filler neck and cap, and improved sealing of the stub pipes was introduced as a "running change" during the 1990 model year.

Interchangeability The new reservoir assembly is interchangeable with the earlier 1990 MY reservoir; however, the new cap is not interchangeable.

Part number Reservoir assembly — CCC 2581

Repair policy Do not replace the early reservoir unless the reservoir is defective (cracks, stub pipe leaks).

If the early reservoir leaks from the cap, install a new style cap seal, part number CCC 2782 as shown.

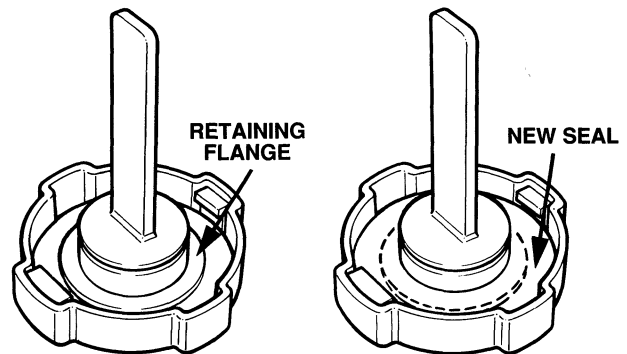

DO NOT LOCATE THE SEAL BEHIND THE RETAINING FLANGE.

RIDE HEIGHT SENSOR

To address the problem of ride leveling strut knock, a revised ride height sensor incorporating a momentary pressure cycle was introduced at VIN 617978. Each time the engine is started, the ride leveling circuit is pressurized for a few seconds, preventing the gradual loss of "trapped line pressure". This action ensures that adequate hydraulic pressure is maintained in the ride leveling struts.

Interchangeability The sensor is an exact replacement for the early sensor; however, the system must be configured as detailed in the repair policy.

Part number Ride height sensor — DBC 6768 or DBC 6170

Repair policy (1988 – 89 MY) Install the new sensor only after ensuring that the late style high pressure hose (pump to valve block) and revised pressure relief valve (valve block) are installed. The late style hose has the part number CCC 2637 stamped on the metal identification band. The revised pressure relief valve is identified visually as shown below.

Repair policy (1990 MY up to VIN 617977) Install the new sensor only after ensuring that the late style high pressure hose (pump to valve block) is installed. The late style hose has the part number CCC 2625 stamped on the metal identification band.

Service procedure Sedan Range Service Manual (ride height sensor); Page 32, this publication (pressure relief valve).

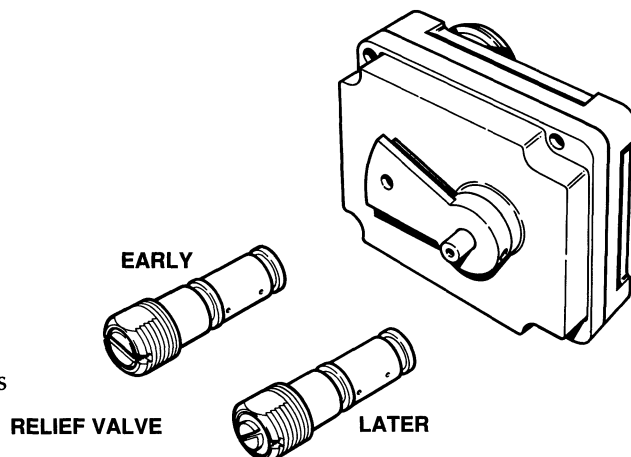

SYSTEM REVISIONS AND REPAIR POLICIES (CONTINUED)

RIDE LEVELING STRUTS

The ride leveling struts underwent many minor revisions identified by the various part numbers.

Interchangeability All ride leveling struts are interchangeable; however, the system must be configured as detailed in the repair policy.

Part number Ride leveling strut (latest specification) — CBC 8892

Repair policy (all struts) Ride leveling struts should only be replaced for knocking sounds if the following conditions are met: after all testing and bleeding procedures have been completed, the struts knock immediately upon vehicle operation. If the struts knock only after a period of time, the trapped line pressure is decaying. Correct this condition by replacing the ride height sensor as detailed previously.

Replacement policy (up to VIN 620606, or part numbers CBC 4214 / CBC5961) Replace both struts as a set.

Replacement policy (VIN 620606 ON, or part number CBC 8892) If the undamaged strut mileage is 25,000 miles or above, replace both struts as a set; if the mileage on the undamaged strut is under 25,000 miles, replace only the damaged strut.

Service procedure Sedan Range Service Manual.

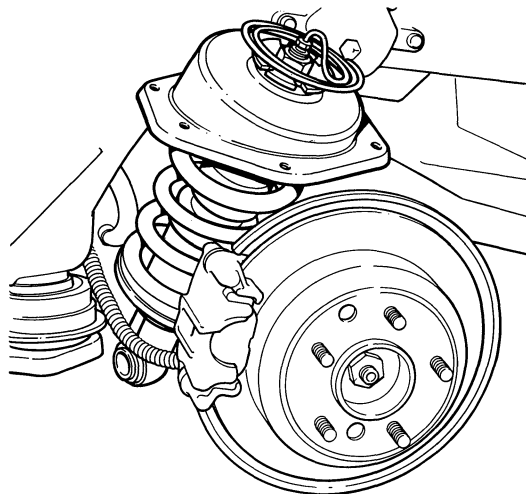

RECALL CAMPAIGN D348

1988 – 89 Model Years

A certain range of 1988 – 89 Model Year Sedan Range vehicles have been recalled for replacement of the pump to valve block high pressure hose and the accumulator switches. This action was taken to correct for the possibility of hose rupture and/or switch leakage. Refer to the subject recall campaign Administration Bulletin and ensure that compliance has been carried out.

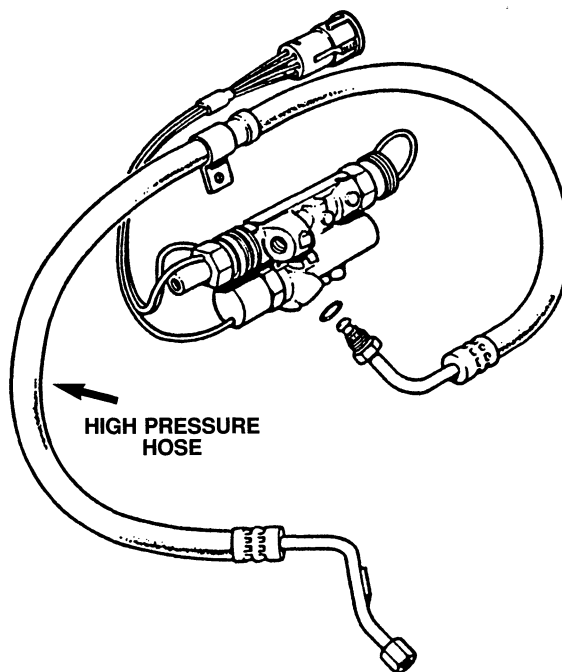
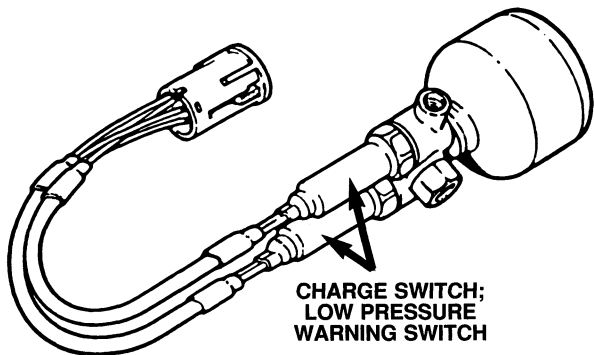

SYSTEM FAULT SYMPTOMS

The following power hydraulic fault symptoms indicate a specific fault that can be corrected without testing.

Accumulator switch(es) leaking If the switch(es) leak, replace individually. Refer to page 14 for parts information; refer to pages 34 – 35 for the installation procedure.

1988 – 89 MY Ensure that the recall campaign has been carried out. Refer to page 16.

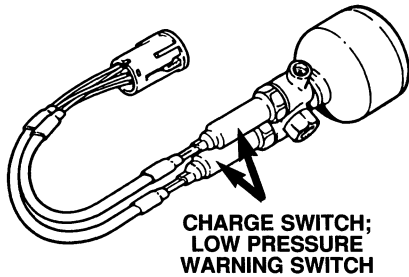

Valve block noise (groan) This “rasping” sound occurs from the area of the valve block shortly after the vehicle is started, or after the vehicle has been parked. The noise is created by the rush of fluid through the down valve. Replace the down valve. Refer to pages 31 – 32 for the installation procedure.

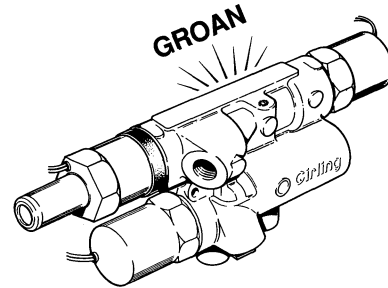

Pump to valve block high pressure hose (1988 – 89 MY) Ensure that the recall campaign has been carried out. Refer to page 16.

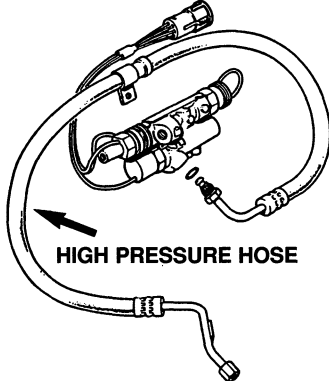

Pedal “off load” valve block noise (1988 – 89 MY) This “barking” sound occurs from the area of the valve block on release of the brake pedal after braking. The noise is created by charge valve vibration. Replace the charge valve. Refer to pages 31 – 32 for the installation procedure.

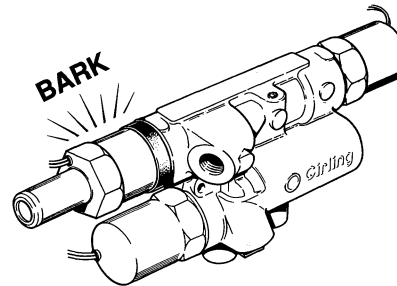

Reservoir leaks (1990 MY ON) If reservoir stub pipe leaks occur, replace the reservoir. Refer to the Sedan Range service manual. If the reservoir cap leaks, replace the cap seal only with the latest style seal. Refer to page 15.

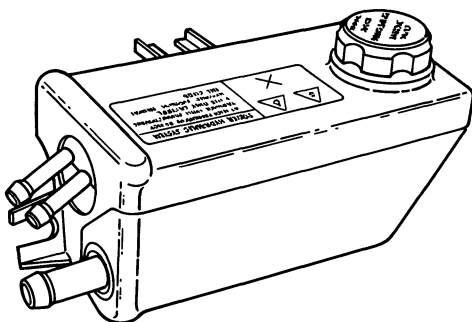

Ride leveling strut knock (vehicles prior to VIN 617978) If strut knock occurs, check that the system has been upgraded as described under Ride Height Sensor, page 15. If necessary, install the required parts to upgrade the system. Refer to page 32 for the relief valve installation procedure.

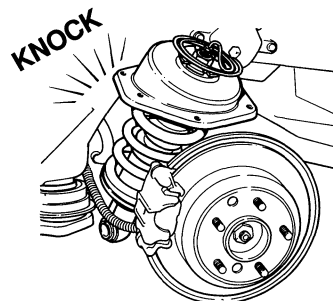



SYSTEM TESTING

Power hydraulic testing

Most diagnostic testing is accomplished using the Jaguar hydraulic test equipment. The test procedures (in "logic tree" form) on the following pages will diagnose a hydraulic or mechanical fault. If electrical diagnosis is required, the test will instruct that JDS diagnosis be carried out. Use the JDS "Power Hydraulics" menu. Ensure that the reservoir level remains correct throughout the tests. As referenced in the tests, refer to the TEST NOTES, pages 28 – 30 for setup and test procedures.

Preliminary test instructions

Ensure that the fluid level is correct in the power hydraulic reservoir and the brake reservoir (1988 – 89 MY). The power hydraulic system uses only Hydraulic System Mineral Oil (HSMO).

! CAUTION: CONTAMINATION OF THE POWER HYDRAULIC OR BRAKE SYSTEM FLUIDS (INTER-MIXING) WILL CAUSE RAPID DETERIORATION OF THE SYSTEM SEALS AND RESULT IN SYSTEM FAILURE.

Visually inspect the systems including all the components and the interconnecting pipes and hoses for leakage and/or damage.

Test equipment

The Jaguar hydraulic test equipment is used to test the power hydraulic system. Use only the green identified hoses and adaptors. In addition to the hydraulic test equipment, JDS diagnosis of some faults is required.

Fault Symptom / Test Sequence

If the power hydraulic system develops one or more of the following fault symptoms, use this table as a guide to testing:

RIDE LEVELING STRUT KNOCK*	– TEST 4, then as directed.
LACK OF RIDE LEVELING STRUT DAMPENING	– TEST 4, then as directed.
VCM LOW PRESSURE WARNING ACTIVATED (1988–89 MY)	– TEST 5, then as directed.
INOPERATIVE RIDE LEVELING; BRAKE BOOST OK (1988–89 MY)	– TEST 2, then as directed.
INOPERATIVE BRAKE BOOST; RIDE LEVELING OK (1988–89 MY)	– TEST 5.
INOPERATIVE POWER HYDRAULICS	– TEST 1, then remaining tests (except TEST 4) as required.

* Vehicles prior to VIN 617978, refer to "Ride leveling strut knock", page 17.

Test "logic tree" symbols



ACTION

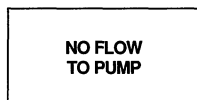

RESULT / OBSERVATION

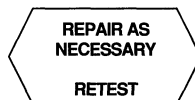

CONCLUSION

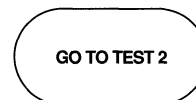

REFERENCE TO ADDITIONAL TEST(S)

! CAUTION: IN ORDER TO ENSURE ACCURATE TEST RESULTS, REPEAT EACH TEST SEGMENT THAT RELIES ON A HYDRAULIC PRESSURE READING BEFORE CONTINUING WITH THE TEST PROCEDURE OR CONDEMNING A COMPONENT.

! CAUTION: CLEANLINESS DURING TESTING IS ESSENTIAL TO ENSURE THAT THE POWER HYDRAULIC SYSTEM IS NOT DAMAGED.

TEST 1: PUMP TEST (ALL MODELS)

CAUTION: IN ORDER TO ENSURE ACCURATE TEST RESULTS, REPEAT EACH TEST THAT RELIES ON A HYDRAULIC PRESSURE READING BEFORE CONTINUING WITH THE TEST PROCEDURE OR CONDEMNING A COMPONENT.

- Depressurize power hydraulic system — 1988 – 89 MY (test note 1, pg. 28)
- Connect test gauge and adaptor to valve block (test notes 2, pg. 28, and 4, pg. 29)
- Start engine and allow hydraulic pressure to stabilize (approx. 1 minute)

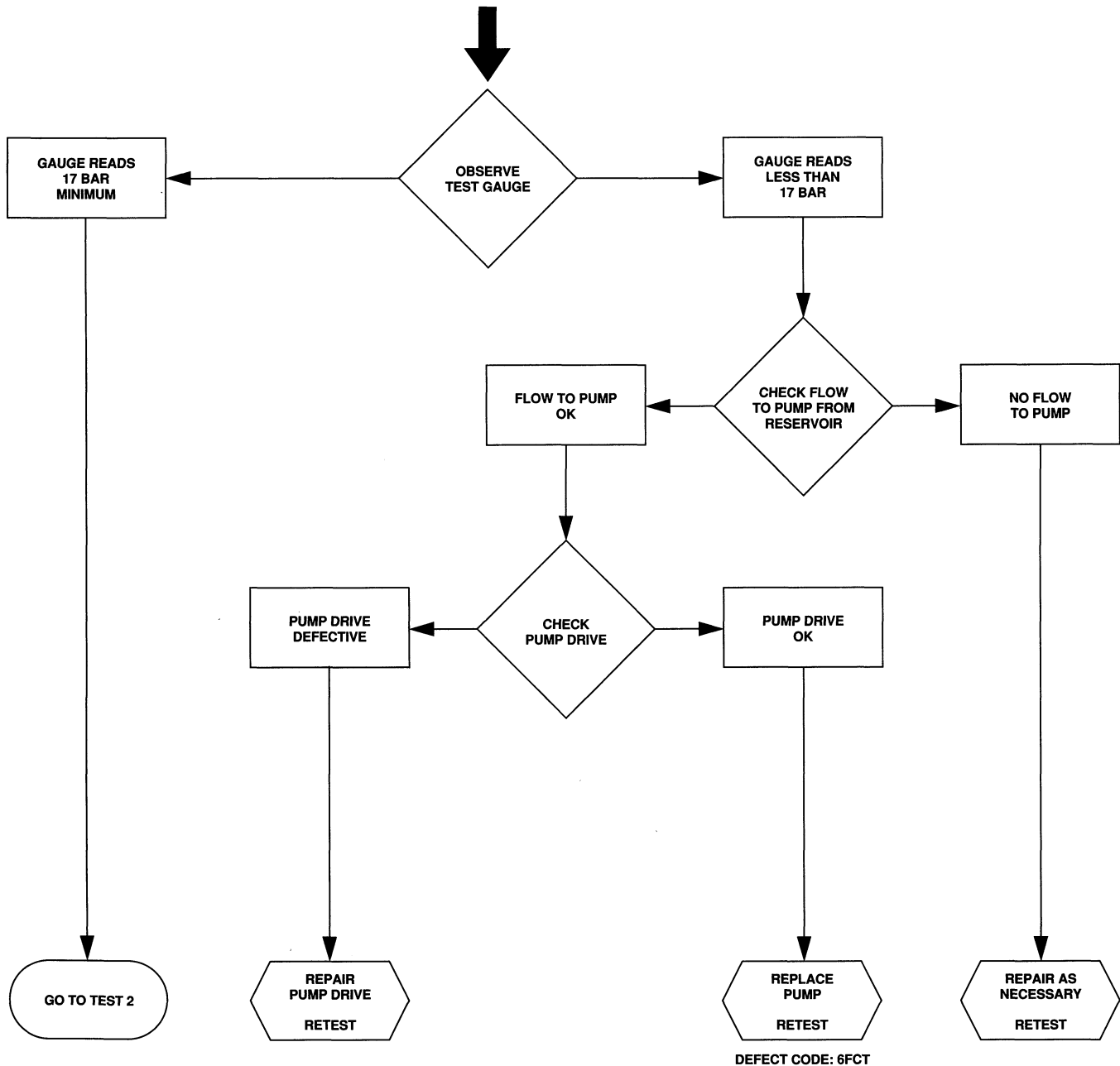

REMOVE TEST EQUIPMENT



TEST 2: CHARGE, UP AND RELIEF VALVES (ALL MODELS)

- Depressurize power hydraulic system — 1988 – 89 MY (test note 1, pg. 28)
- Connect test gauge and adaptor to valve block (test notes 2, pg. 28, and 4, pg. 29)
- Raise vehicle on ramp
- Disconnect and raise ride height sensor link arm (test note 6, pg. 30)
- Start engine and allow to idle

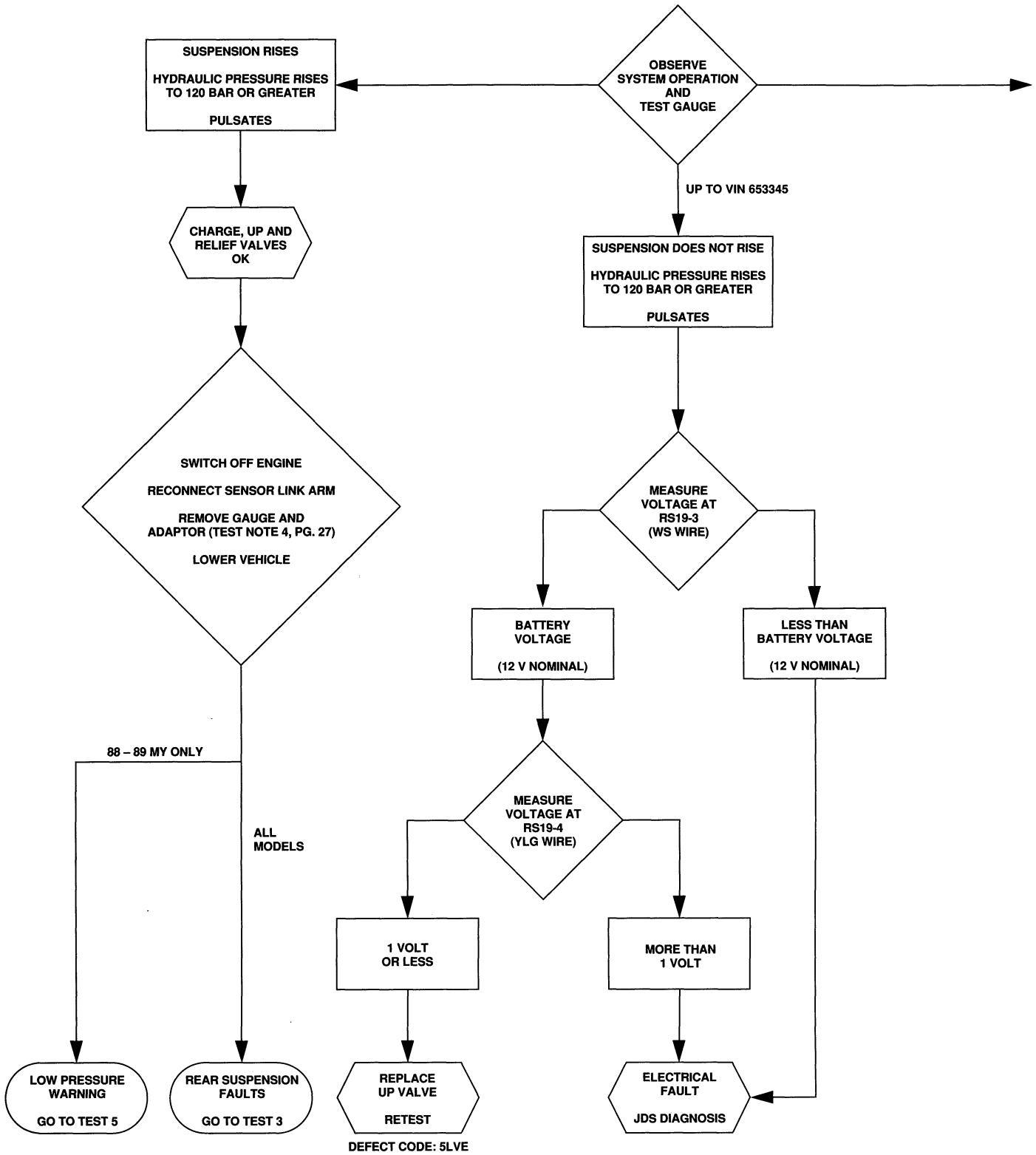

REMOVE TEST EQUIPMENT

CAUTION: IN ORDER TO ENSURE ACCURATE TEST RESULTS, REPEAT EACH TEST THAT RELIES ON A HYDRAULIC PRESSURE READING BEFORE CONTINUING WITH THE TEST PROCEDURE OR CONDEMNING A COMPONENT.

NOTE: Take all voltage measurements within 5 minutes of switching on ignition. If more time is required, switch off ignition and then switch on again.

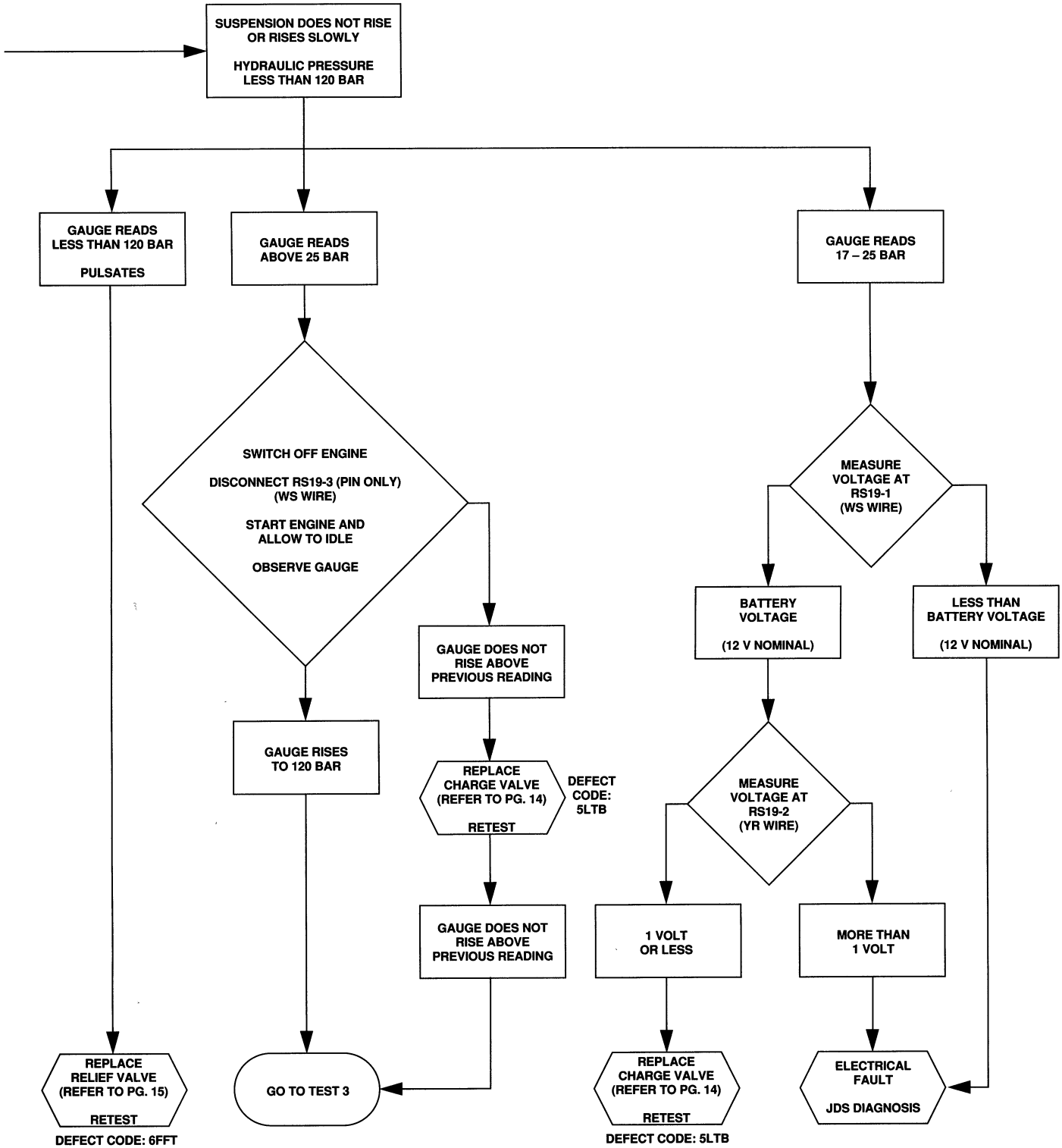

REMOVE TEST EQUIPMENT

TEST 3: DOWN VALVES (ALL MODELS)

- Raise vehicle on ramp
- Connect test gauge and adaptor to strut bleed elbow (test note 5, pg. 29)
- Raise ride height sensor link arm (test note 6, pg. 30)
- Start engine and allow system to reach maximum pressure

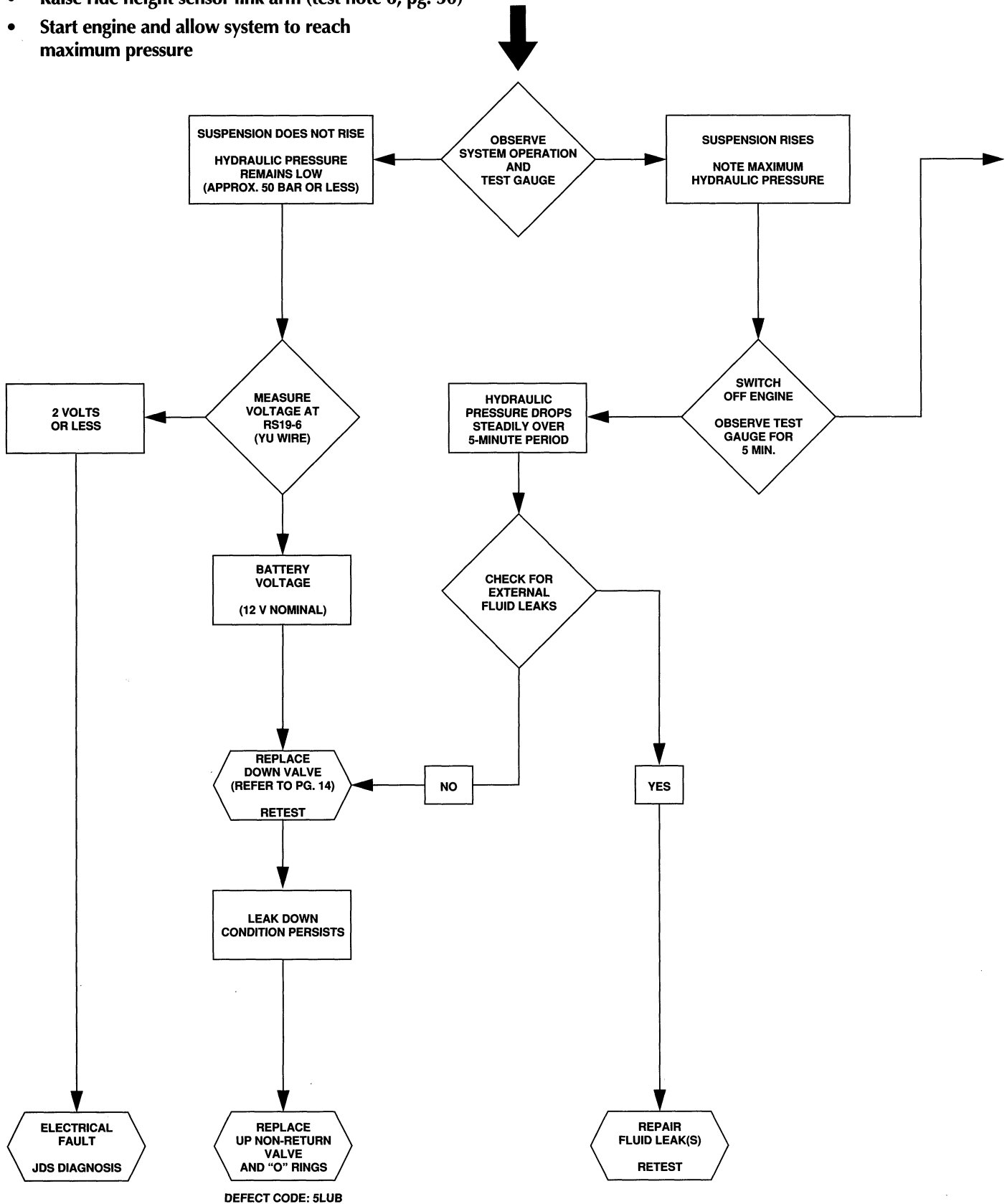

CAUTION: IN ORDER TO ENSURE ACCURATE TEST RESULTS, REPEAT EACH TEST THAT RELIES ON A HYDRAULIC PRESSURE READING BEFORE CONTINUING WITH THE TEST PROCEDURE OR CONDEMNING A COMPONENT.

NOTE: Take all voltage measurements within 5 minutes of switching on ignition. If more time is required, switch off ignition and then switch on again.

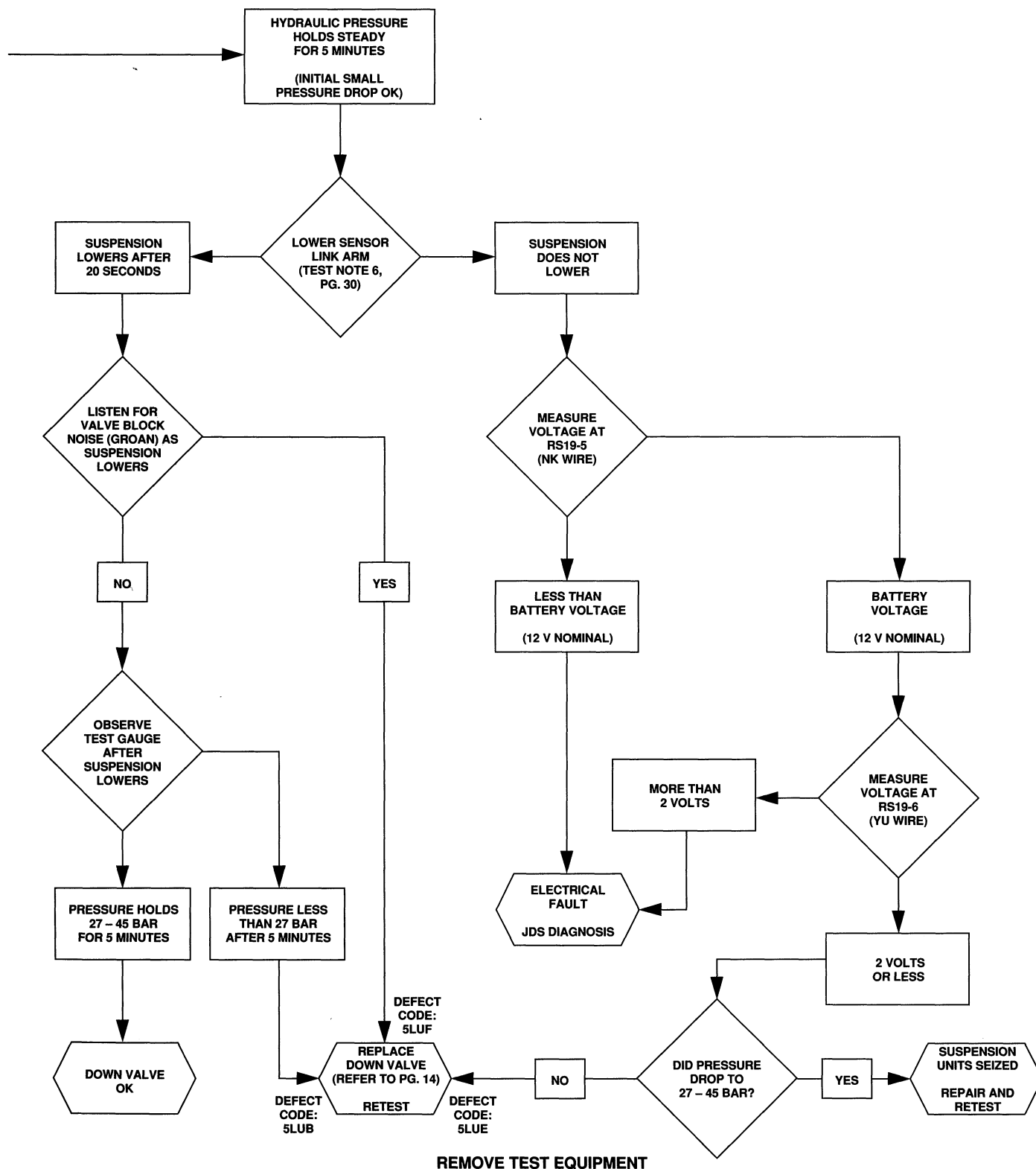



TEST 4: RIDE LEVELING QUICK TEST (ALL MODELS)

- Raise vehicle on ramp
- Raise ride height sensor link arm (test note 6, pg. 30)
- Start engine and allow to idle

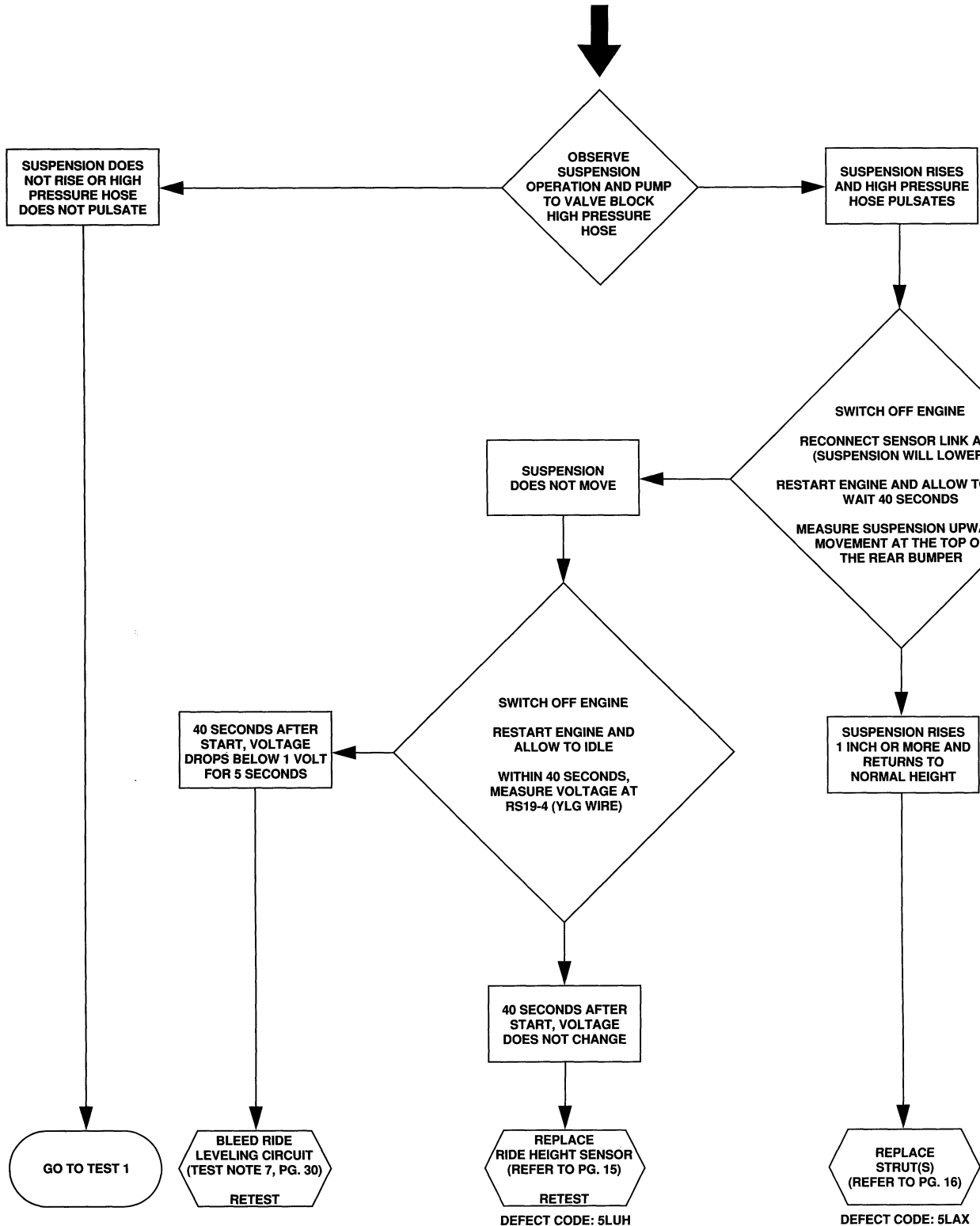

REMOVE TEST EQUIPMENT

CAUTION: IN ORDER TO ENSURE ACCURATE TEST RESULTS, REPEAT EACH TEST THAT RELIES ON A HYDRAULIC PRESSURE READING BEFORE CONTINUING WITH THE TEST PROCEDURE OR CONDEMNING A COMPONENT.

NOTE: Take all voltage measurements within 5 minutes of switching on ignition. If more time is required, switch off ignition and then switch on again.

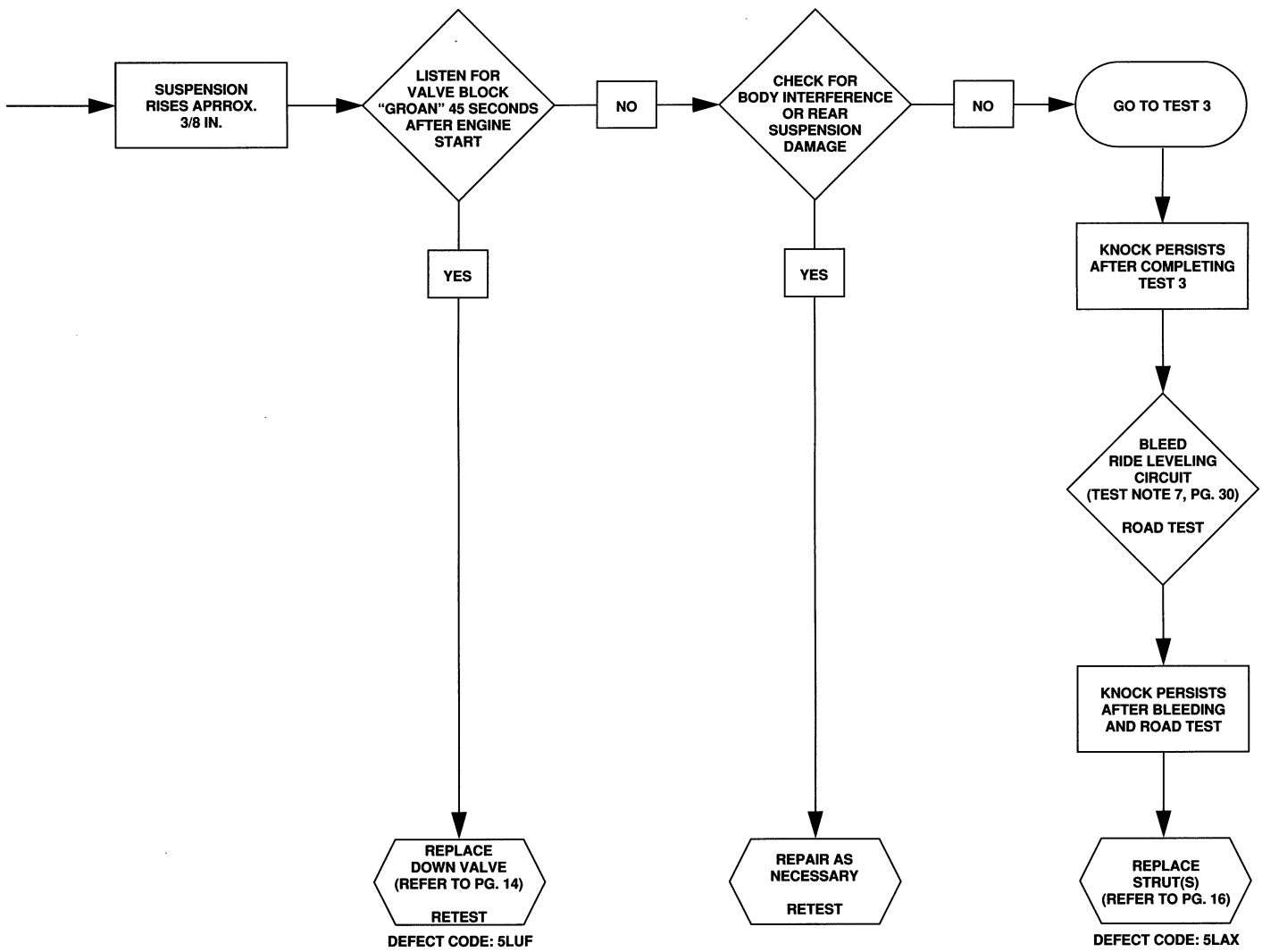

DEFECT CODE: 5LUF

DEFECT CODE: 5LAX

REMOVE TEST EQUIPMENT



TEST 5: ACCUMULATOR ASSEMBLY AND BOOSTER (1988 – 89 MY ONLY)

- Start engine; run for 25 seconds @1000 rpm
- Switch off engine; switch on ignition (II)
- Press brake pedal firmly
- Release and repeat every 3 seconds
- Observe the VCM for "BRAKE FAILURE" or "LOW BRAKE PRESSURE" warning

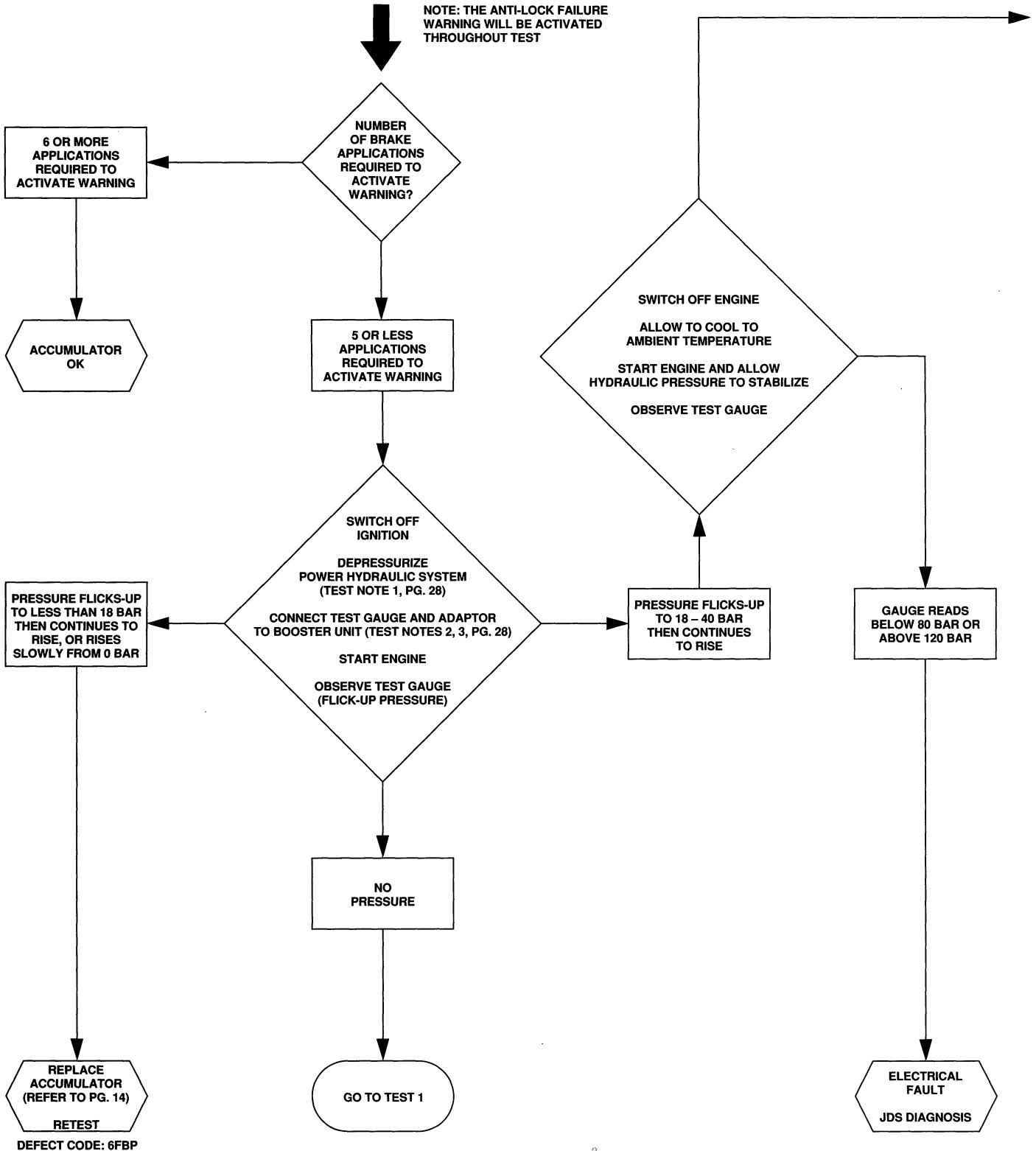



TEST NOTES

TEST NOTE 1

Depressurize the power hydraulic system (1988 – 89 MY)

Depressurize the system by pumping the brake pedal until it feels hard (approximately 18 applications).

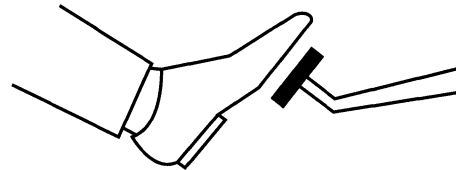

(APPROXIMATELY 18 APPLICATIONS)

TEST NOTE 1

TEST NOTE 2

Connect test hose to test gauge

Connect the hose to the test gauge before connection to the adaptor. This sequence will prevent the possibility of high pressure fluid loss. "Zero" the reference needle before taking each reading.

! WARNING: To prevent the possibility of injury from high pressure fluid loss, always connect the hose to the test gauge before connection to the adaptor.

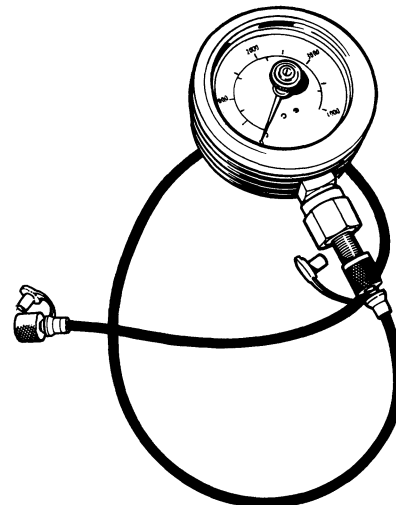

TEST NOTE 2

TEST NOTE 3

Install and remove booster test adaptor (1988 – 89 MY)

INSTALL

- Disconnect the power hydraulic feed pipe at the booster.
- Install adaptor JAO (10 mm thread) with the seal washer in the booster feed port.
- Connect the feed pipe to the adaptor.
- Remove the most accessible adaptor plug.
- Connect the test gauge by test point 4 (6 mm thread) with the seal washer.

REMOVE

- Switch off engine.
- Depressurize the system (Test Note 1).
- Remove the test gauge and hose assembly.
- Remove the adaptor and test point.
- Reconnect the feed pipe.

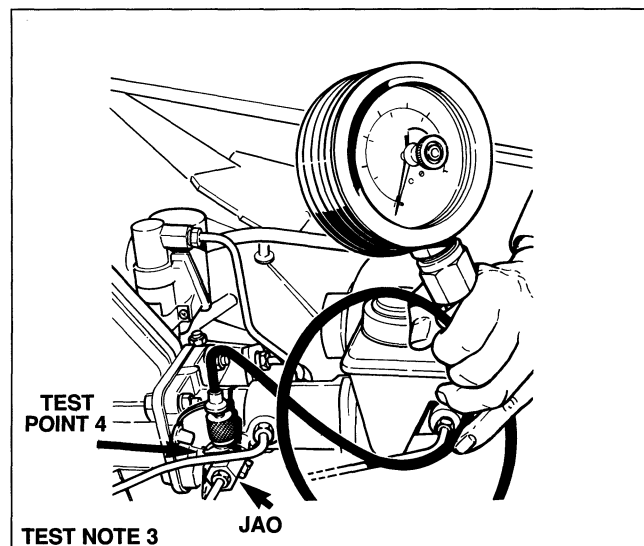

TEST NOTE 3

TEST NOTE 4

Install and remove valve block test adaptor

INSTALL

- Disconnect the power hydraulic feed pipe at the valve block.
- Install adaptor JRVO (12 mm thread) with the seal washer in the valve block feed port. The direction arrow should point to the valve block.
- Connect the feed pipe to the adaptor.
- Remove the most accessible adaptor plug.
- Connect the test gauge by test point 4 (6 mm thread) with the seal washer.

REMOVE

- Switch off engine.
- Remove the test gauge and hose assembly.
- Remove the adaptor and test point.
- Reconnect the feed pipe.

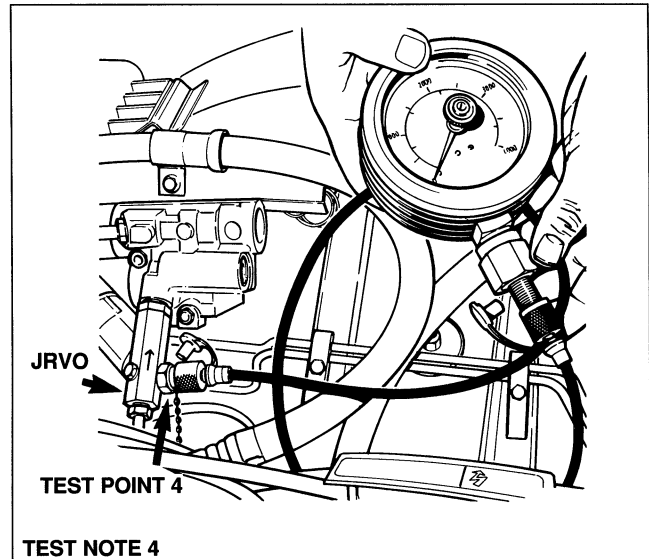

TEST NOTE 5

Install and remove test adaptor and gauge to strut bleed elbow

INSTALL

- Drive the vehicle on a ramp (wheels must support the weight of the vehicle).
- Remove the ride leveling bleed adaptor cover (at left strut) and connect a hose.
- Open the bleed screw and allow fluid flow until the suspension lowers fully.
- Remove the bleed screw.
- Install adaptor JDS 9007/1 with the seal washer in the bleed screw tapping.
- Install test point 5 (12 mm thread) with the seal washer in the adaptor.
- Connect the test hose and gauge to the test point.

REMOVE

- Disconnect and lower the ride height sensor link arm. Wait 20 seconds. (Test Note 6)
- Suspend the rear wheels.
- Remove the test gauge and hose assembly.
- Remove the adaptor and test point.
- Install the bleed nipple.
- Bleed system (Test Note 7)

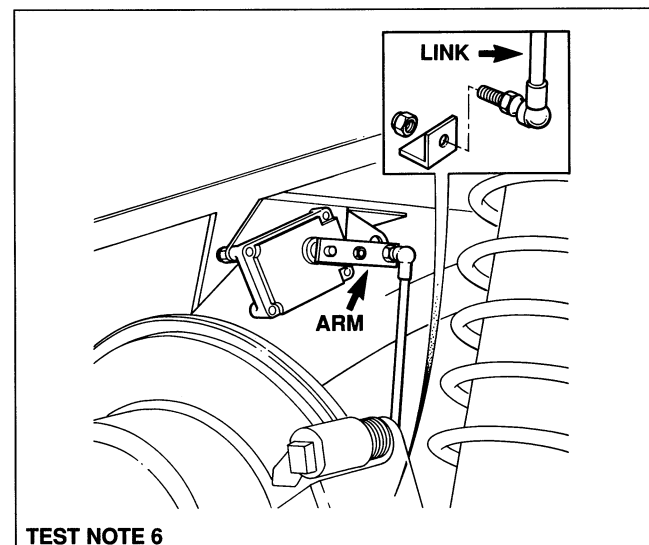
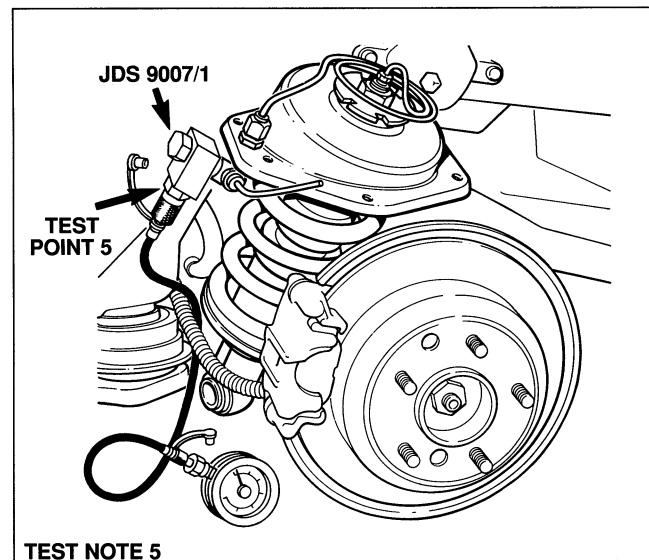

TEST NOTE 6

Activate rear suspension

- Drive the vehicle on a ramp (wheels must support the weight of the vehicle). Apply the parking brake; place gear selector in P (park). Start the engine and raise the ramp.
- Disconnect the ride height sensor link rod at the suspension wishbone.
- Raise the sensor link approximately 1 inch. The rear of the vehicle will rise.
- The valve block relief valve will be heard and the feed pipe will pulsate when the relief valve operates.

TEST NOTE 7

Bleed power hydraulic system

! CAUTION: USE ONLY HSMO WHEN FILLING THE RESERVOIR.

- Drive the vehicle on a ramp (wheels must support the weight of the vehicle).
- Top-up the power hydraulic reservoir as necessary.
- Apply the parking brake; place gear selector in P (park).
- Start the engine and raise the ramp.
- Disconnect the ride height sensor link rod at the suspension wishbone.
- Raise the sensor link approximately 1 inch. The rear of the vehicle will rise.
- Switch off the engine when "pulsing" is felt in the strut feed pipe.
- Remove the bleed adaptor cover (at left strut) and connect a hose for bleeding.
- Open the bleed screw and allow fluid flow until the suspension lowers fully.
- Lower the ramp and top-up the reservoir.
- Start the engine and repeat the bleeding operation.
- Remove the bleed hose and reinstall the dust cover.
- Lower the ramp and top-up the reservoir.
- Start the engine and raise the ramp.
- Raise the rear of the vehicle by moving the sensor link.
- When "pulsing" is felt in the strut feed pipe, reconnect the sensor link to the suspension wishbone. The vehicle will return to the normal ride height.
- Lower the ramp and top-up the reservoir.

1990 MY ON vehicles only

- Start and run the engine for 30 seconds. Turn the steering wheel lock-to-lock three times. Allow the engine to run an additional 1 minute.
- Switch off the engine and allow vehicle to stand for 5 minutes. Top-up the reservoir after the 5-minute period.

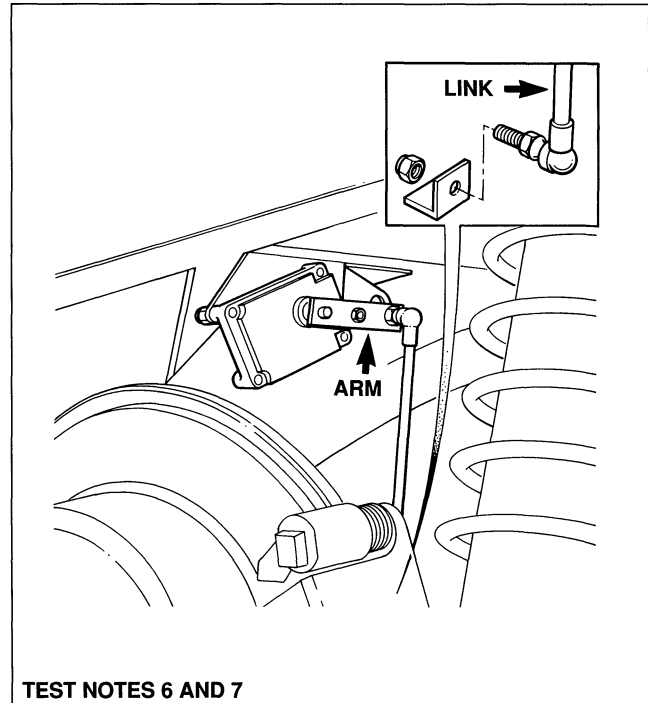

TEST NOTES 6 AND 7

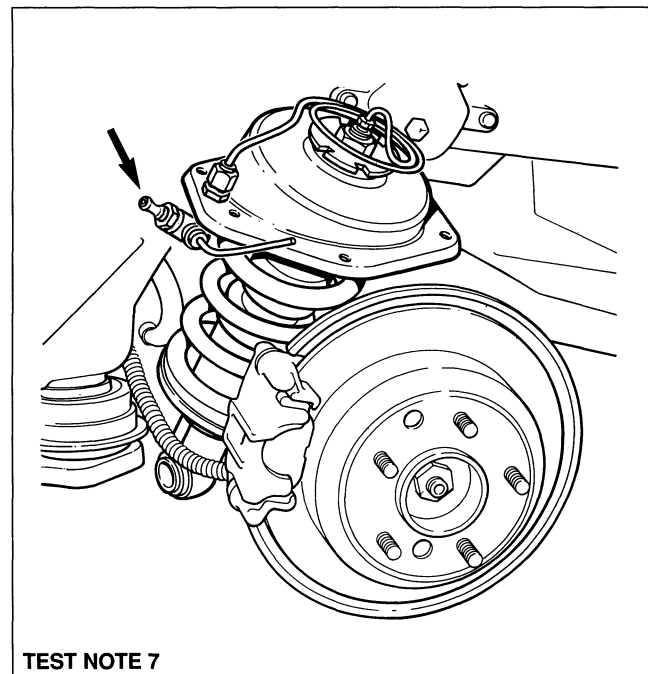

TEST NOTE 7

Except for the two procedures contained in this publication, refer to the Sedan Range Service Manual for power hydraulic service procedures.

VALVE BLOCK COMPONENT REPLACEMENT

If a valve block failure occurs, the component(s) should be replaced individually. The charge and down valves can be replaced without removing the valve block from the vehicle. Replacement of the up valve and non-return valve requires that the valve block be removed from the vehicle.

! CAUTION: CLEANLINESS IS ESSENTIAL TO ENSURE THAT THE SYSTEM COMPONENTS ARE NOT DAMAGED.

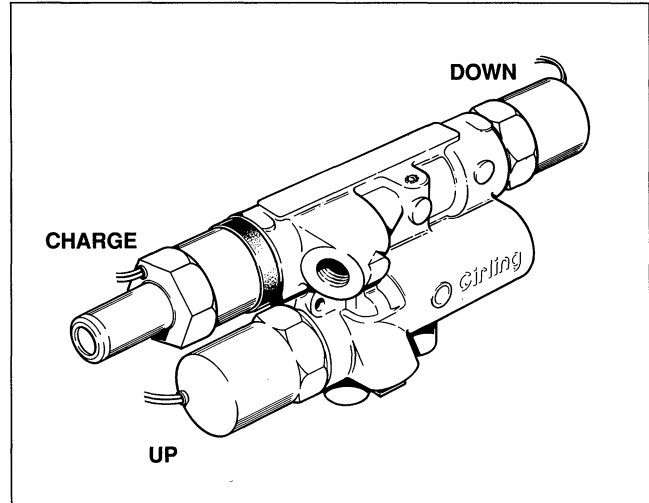

VALVE BLOCK REMOVAL AND INSTALLATION

REMOVAL

- Clean the valve block and surrounding area.
- Depressurize the brake boost circuit (Test Note 1, page 28) (1988 – 89 MY).
- Depressurize the ride leveling hydraulic circuit (Test Note 5, page 29)
- Disconnect the battery positive cable.
- Remove the tie wraps securing the wiring harness.
- Disconnect the PM4 connector.
- Remove the feed pipe clamp from the inner fender.
- Remove the valve block securing nuts.
- Protect against escaping fluid.
- Loosen the pipe unions and disconnect the pipes.
- Install protective caps on the pipes.
- Carefully remove the valve block.

INSTALLATION

- Reverse the removal procedure.
- Top up the reservoir.
- Exercise and/or bleed the ride leveling system to remove any trapped air (Test Notes 6 and 7, pages 29 – 30).

TORQUE SPECIFICATIONS

10 mm Unions	9 – 11 Nm (7 – 8 lb ft)
12 mm Unions	16 – 19 Nm (12 – 14 lb ft)
14 mm Unions	16 – 19 Nm (12 – 14 lb ft)

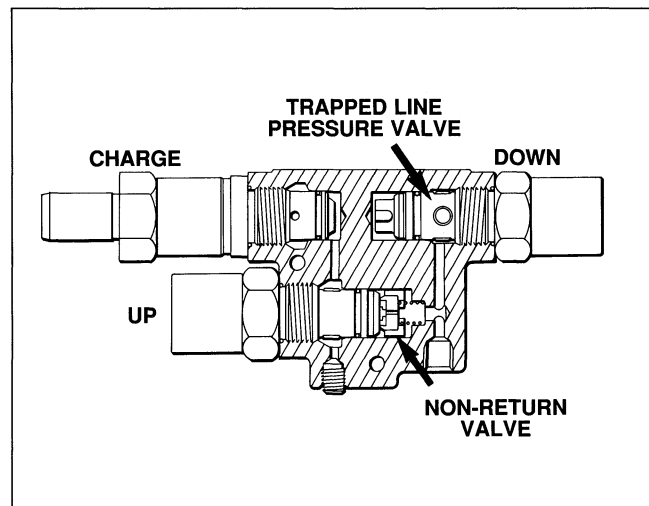

PRESSURE RELIEF VALVE REMOVAL AND INSTALLATION

REMOVAL

- Clean the valve block and surrounding area.
- Reposition hoses as necessary to gain access to the relief valve.
- Position an open end wrench across the valve block over the area of the "Girling" insignia.
- While applying counter force with the open end wrench, remove the relief valve using tool JD 176. The tool should be firmly seated against the face of the valve during removal.

INSTALLATION

- Reverse the removal procedure.
- Top-up the reservoir.

TORQUE SPECIFICATION

Pressure relief valve 20 – 24 Nm (15 – 18 lb ft)

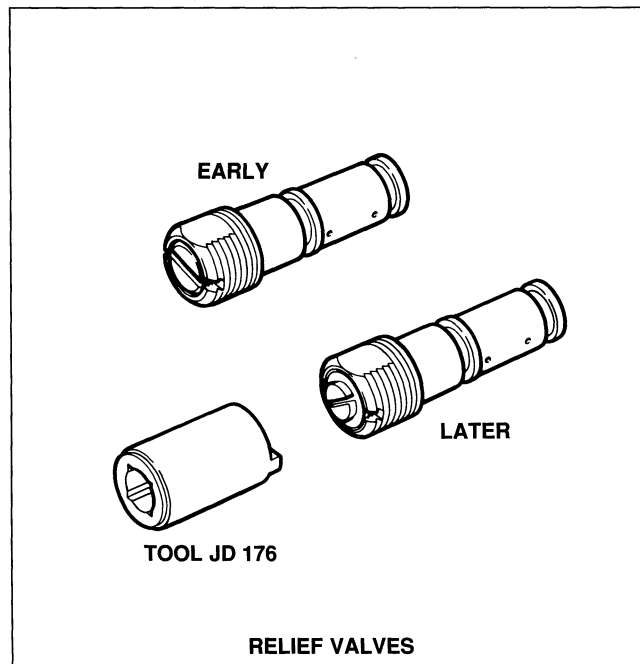

VALVE REMOVAL AND INSTALLATION (CHARGE AND DOWN VALVES)

REMOVAL

- Remove the anti-backout plate and seals from the PM4 connector. Remove the required pins from the connector using tool JD 137.
- Protect against escaping fluid.
- Loosen and remove the valve assembly.

INSTALLATION

- Screw the valve assembly into the valve block. Tighten to a torque of 35 – 45 Nm (26 – 33 lb ft).
- Reassemble the pins in the PM4 connector.
- Wrap the wires with insulating tape.
- Reconnect the connector and secure with tie wraps.
- Top-up the reservoir as necessary.
- Exercise and/or bleed the ride leveling system to remove any trapped air (Test Notes 6 and 7, pages 29 – 30).

TORQUE SPECIFICATION

Charge and down valves 35 – 45 Nm (26 – 33 lb ft)

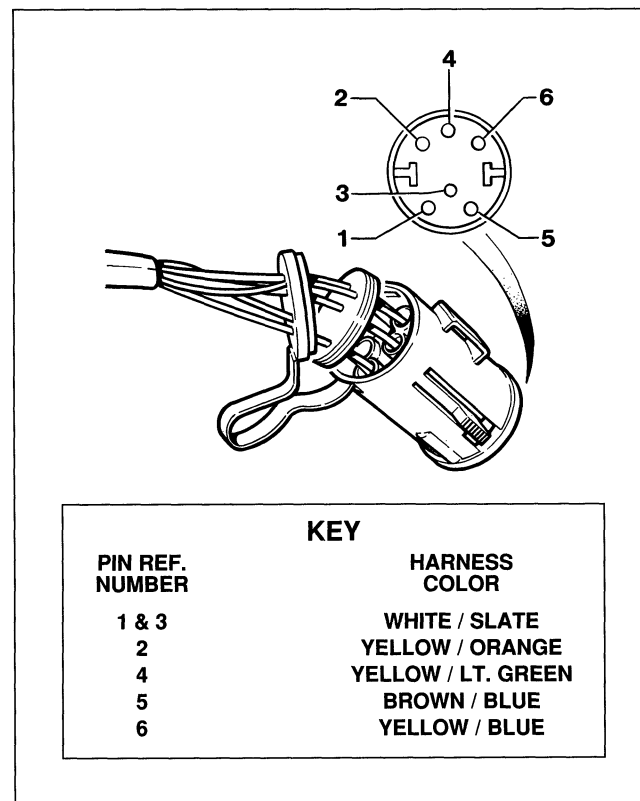

VALVE REMOVAL AND INSTALLATION (UP AND NON-RETURN VALVES)

REMOVAL

- Remove the valve block (page 31).
- Remove the anti-backout plate and seals from the PM4 connector. Remove the required pins from the connector using tool JD 137.
- Clamp the valve block in a vise by the lugs with the up valve facing up.
- Loosen and remove the up valve assembly.
- Spread out a clean cloth on a flat surface. Remove the valve block and turn upside down allowing the non-return valve and spring to fall out.

INSTALLATION

- If the original up valve is to be reused, replace the "O" rings on the valve.
- Clamp the valve block in a vise by the lugs with the up valve facing up.
- Install the spring into the valve block bore using a clean rod or wire as a guide.
- Install the non-return valve on top of the spring using a pair of long tweezers. Ensure that the valve seal faces up and that the valve is centered over the spring.
- Screw the up valve assembly into the valve block. Tighten to a torque of 35 – 45 Nm (26 – 33 lb ft).
- Reassemble the pins in the PM4 connector. Install the seal and anti-backout plate.
- Wrap the wires with insulating tape.
- Reinstall the valve block (page 31).

TORQUE SPECIFICATION

Charge and down valves 35 – 45 Nm (26 – 33 lb ft)

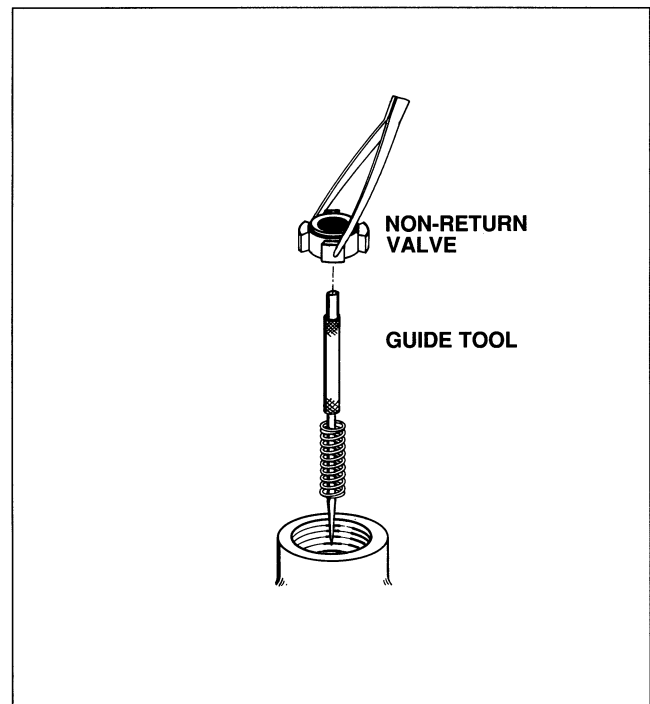
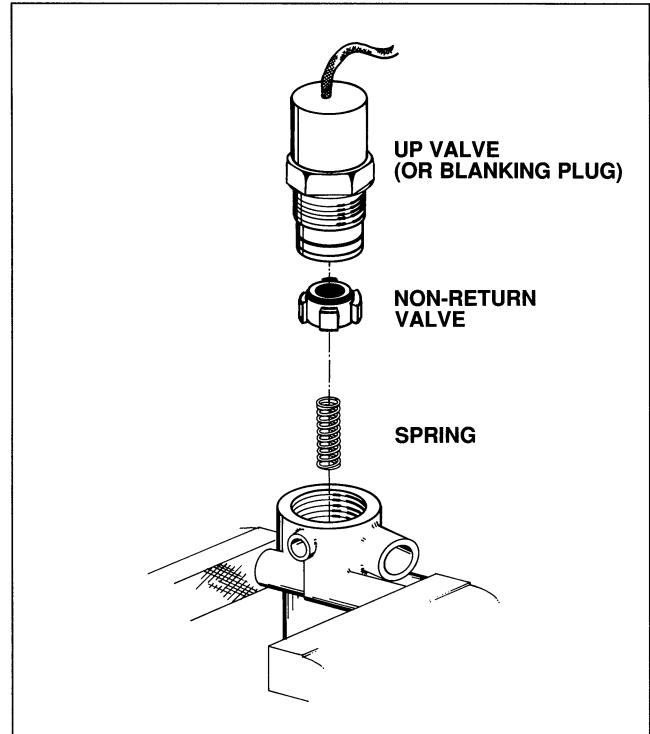

SERVICE PROCEDURES (continued)

ACCUMULATOR COMPONENT REPLACEMENT (1988 – 89 MY)

If an accumulator failure occurs, the component(s) should be replaced individually. Replacement of the accumulator vessel requires that the accumulator assembly be removed from the vehicle. The charge and low pressure switches can be replaced without removing the accumulator assembly from the vehicle.

CAUTION: CLEANLINESS IS ESSENTIAL TO ENSURE THAT THE ACCUMULATOR COMPONENTS ARE NOT DAMAGED.

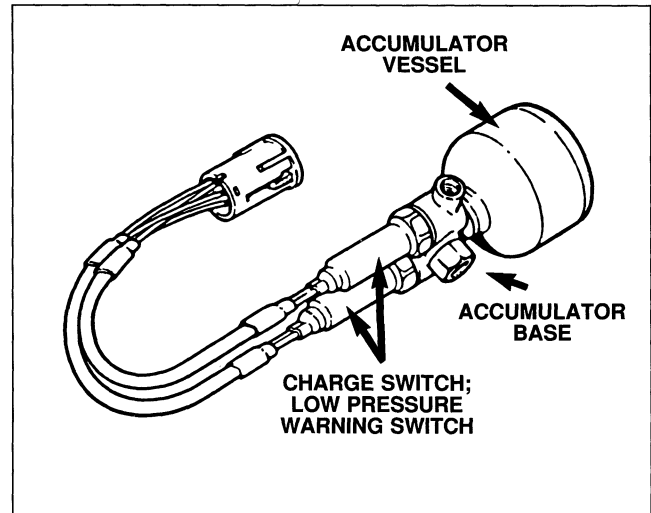

ACCUMULATOR ASSEMBLY REMOVAL AND INSTALLATION

REMOVAL

- Depressurize the brake boost circuit (Test Note 1, page 28).
- Remove the tie wraps securing the wiring harness connector.
- Disconnect the PM4 connector.
- Raise the vehicle on a lift.
- Clean the accumulator and surrounding area.
- Protect against escaping fluid.
- Loosen the pipe unions and disconnect the pipes from the accumulator.
- Install protective caps on the pipes and accumulator.
- Remove the accumulator clamp hardware.
- Carefully remove the accumulator assembly.

INSTALLATION

- Reverse the removal procedure.
- Lower the vehicle and connect the PM4 connector. Secure with tie wraps.
- Start the engine and allow the system to pressurize.
- Carefully check for leaks. Switch off the engine.
- Top-up the reservoir.

TORQUE SPECIFICATIONS

10 mm Unions

9 – 11 Nm (7 – 8 lb ft)

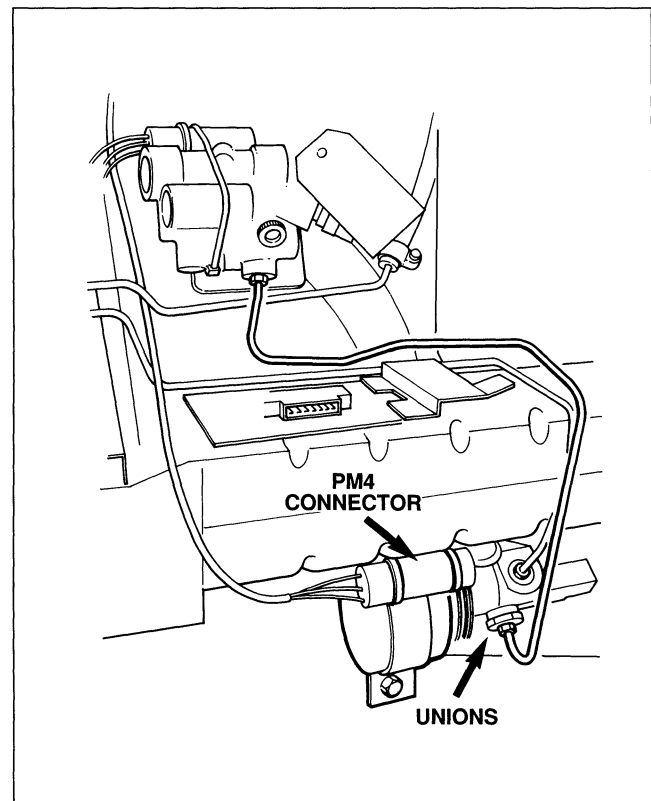

ACCUMULATOR VESSEL REPLACEMENT

- Place the accumulator assembly on a flat surface and remove the protective cap from the non-return valve union.
- To ensure cleanliness, place a piece of adhesive tape over the non-return valve orifice.
- Clamp the accumulator assembly in a vise protected with soft jaws. Clamp across the non-return valve orifice face and the casting lug.
- Remove the accumulator vessel using a strap type oil filter tool.
- Check that a new "O" ring is installed to the replacement accumulator vessel thread face.
- Install and tighten the accumulator vessel using the strap-type oil filter tool.
- Remove the assembly from the vise and remove the adhesive tape.
- Install the accumulator assembly on the vehicle (above).

TORQUE SPECIFICATION

Accumulator vessel **28 – 36 Nm (21 – 26 lb ft)**

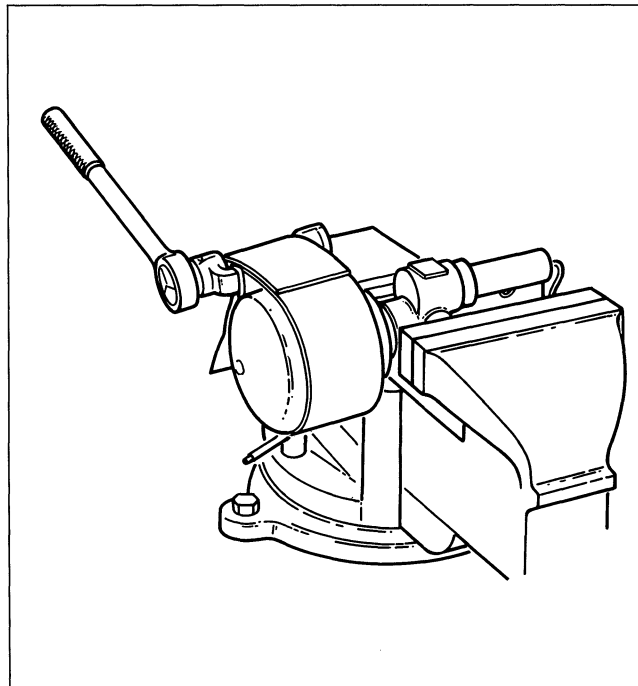

ACCUMULATOR SWITCH REPLACEMENT (CHARGE SWITCH OR LOW PRESSURE WARNING SWITCH)

- Depressurize the brake boost circuit (Test Note 1, page 28).
- Remove the tie wraps securing the wiring harness connector.
- Disconnect the PM4 connector.
- Feed the harness down through the engine compartment.
- Raise the vehicle on a lift.
- Cut and remove the heat shrink sleeve surrounding the switch harnesses.
- Remove the anti-backout plate and seals from the PM4 connector. Remove the required pins from the connector using tool JD 137.
- Clean the accumulator and surrounding area.
- Protect against escaping fluid.
- Remove the switch(es) from the accumulator base.
- Install and tighten the replacement switch(es) in the accumulator base.
- Reassemble the pins in the PM4 connector. Install the seal and the anti-backout plate.
- Wrap the wires together with insulating tape.
- Feed the harness up through the engine compartment.
- Lower the vehicle and connect the connector. Secure with tie wraps.
- Start the engine and allow the system to pressurize.
- Carefully check for leaks. Switch off the engine.
- Top up the reservoir.

TORQUE SPECIFICATION

Accumulator switches **31 – 39 Nm (23 – 28 lb ft)**

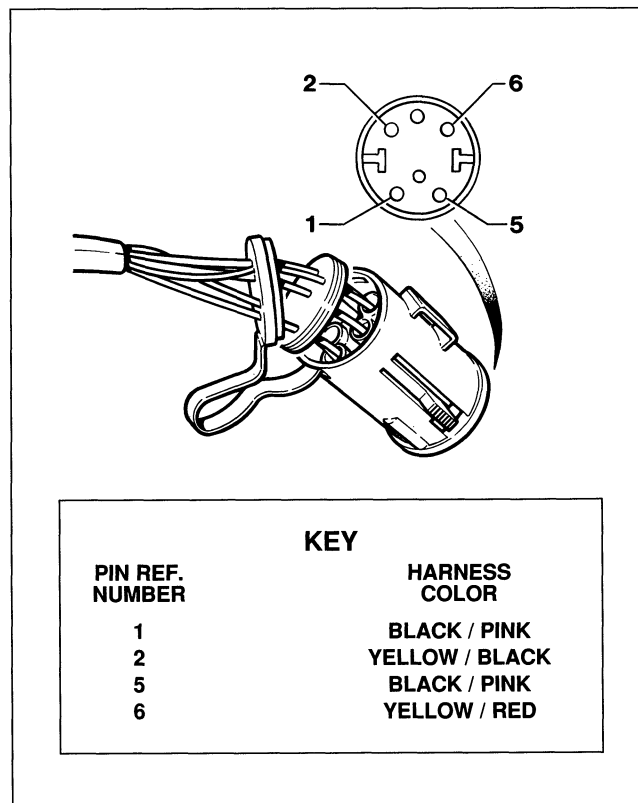



PRESSURE CONVERSION CHART

One bar is the atmospheric pressure at sea level on a standard temperature (59° F) day.

BAR TO POUNDS PER SQUARE INCH (psi)			
bar	psi	bar	psi
1	14.504	155	2248
5	73	160	2321
10	145	165	2393
15	218	170	2466
20	290	175	2538
25	363	180	2611
30	435	185	2683
35	508	190	2756
40	580	195	2828
45	653	200	2901
50	725	205	2973
55	798	210	3046
60	870	215	3118
65	943	220	3191
70	1015	225	3263
75	1088	230	3336
80	1160	235	3408
85	1233	240	3481
90	1305	245	3553
95	1378	250	3626
100	1450	255	3699
105	1523	260	3771
110	1595	265	3844
115	1668	270	3916
120	1740	275	3989
125	1813	280	4061
130	1886	285	4134
135	1958	290	4206
140	2031	295	4279
145	2103	300	4351
150	2176		





NOTES



PRINTED IN USA
JAGUAR CARS INC.
