



BY APPOINTMENT TO  
HER MAJESTY QUEEN ELIZABETH II  
MANUFACTURERS OF DAIMLER AND JAGUAR CARS  
JAGUAR CARS LIMITED COVENTRY ENGLAND



BY APPOINTMENT TO  
HER MAJESTY QUEEN ELIZABETH  
THE QUEEN MOTHER  
MANUFACTURERS OF DAIMLER AND JAGUAR CARS  
JAGUAR CARS LIMITED COVENTRY ENGLAND



BY APPOINTMENT TO  
HIS ROYAL HIGHNESS THE PRINCE OF WALES  
MANUFACTURERS OF DAIMLER AND JAGUAR CARS  
JAGUAR CARS LIMITED COVENTRY



# SERIES III SERVICE MANUAL

## Introduction

The Service Manual covers the Jaguar and Daimler Series III range of vehicles. It is primarily designed to assist skilled technicians in the efficient repair and maintenance of Jaguar vehicles.

Using the appropriate service tools and carrying out the procedures will enable the operations to be completed within the time stated in the 'Repair Operations Times'.

The Service Manual has been produced in one loose leaf book; this allows pages to be updated periodically when modifications and improvements occur.

The table of contents following this introduction lists the major components and systems together with the section in which they are contained. Each section starts with a list of operations in alphabetical order.

## Operation Numbering

A master index of numbered operations has been compiled for universal application to all vehicles manufactured by Jaguar Cars Limited, and therefore, because of the different specifications of various models, continuity of the numbering sequence is not maintained throughout this manual.

Each operation described in this manual is allocated a number from the master index and cross-refers with an identical number in the 'Repair Operation Times'. The number consists of six digits arranged in three pairs.

Each operation is laid out in the sequence required to complete the operation in the minimum time, as specified in the 'Repair Operation Times'.

## Service Tools

Where performance of an operation requires the use of a service tool, the tool number is quoted under the operation heading and is repeated in, or following the instruction involving its use. A list of all necessary tools is included in Section 11.

## References

References to the left or right-hand side of the vehicle are made when viewing from the rear. With the engine and gearbox assembly removed, the timing cover end of the engine is referred to as the front. A key to abbreviations and symbols is given in Section 01.

## REPAIRS AND REPLACEMENTS

When service parts are required it is essential that only genuine Jaguar/Daimler replacements are used.

Attention is particularly drawn to the following points concerning repairs and the fitting of replacement parts and accessories.

1. Safety features embodied in the vehicle may be impaired if other than genuine parts are fitted. In certain territories, legislation prohibits the fitting of parts not to the vehicle manufacturer's specification.
2. Torque wrench setting figures given in this Service Manual must be strictly adhered to.
3. Locking devices, where specified, must be fitted. If the efficiency of the locking device is impaired during removal, it must be replaced.
4. Owners purchasing accessories while travelling abroad, should ensure that the accessory and its fitted location on the vehicle, conform to mandatory requirements existing in their country of origin.
5. The vehicle warranty may be invalidated by the fitting of other than genuine Jaguar parts. All Jaguar replacements have the full backing of the factory warranty.
6. Jaguar/Daimler Dealers are obliged to supply only genuine service parts.

## SPECIFICATION

Purchasers are advised that the specification details set out in this manual apply to a range of vehicles and not to any one. For the specification of a particular vehicle, purchasers should consult a Jaguar/Daimler dealer.

The Manufacturers reserve the right to vary their specifications with or without notice, and at such times and in such a manner as they think fit. Major as well as minor changes may be involved in accordance with the Manufacturer's policy of constant product improvement.

Whilst every effort is made to ensure the accuracy of the particulars contained in this Manual, neither the Manufacturer or the Dealer, by whom this Manual is supplied, shall in any circumstances be held liable for any inaccuracy or the consequences thereof.

## COPYRIGHT

© Jaguar Cars Limited. 1988

All rights reserved. No part of this publication may be reproduced, stored in a retrieval system or transmitted in any form, electronic, mechanical, photocopying, recording or any other means without prior written permission of Jaguar Cars Limited, Service Department, Radford, Coventry CV6 3GB.

**TABLE OF CONTENTS**

<b>SECTION</b>	<b>SECTION No</b>
Introduction .....	01
General specification data .....	04
Engine tuning data .....	05
Torque wrench settings – refer to each individual section	
General fitting instructions .....	07
Lifting, Jacking and Towing .....	08
Recommended lubricants, fluids, capacities and dimensions .....	09
Maintenance .....	10
Service tools .....	11
Engine .....	12 – 6 cylinder
Engine .....	12 – 12 cylinder
Emission control .....	17 – 6 cylinder engines
Emission control .....	17 – 12 cylinder engine
Fuel system (including fuel injection) .....	19 – 6 cylinder engines
Fuel system (including fuel injection) .....	19 – 12 cylinder engine
Cooling system .....	26 – 6 cylinder engines
Cooling system .....	26 – 12 cylinder engine
Manifold and exhaust system .....	30 – 6 cylinder engines
Manifold and exhaust system .....	30 – 12 cylinder engine
Clutch .....	33
Manual gearbox .....	37
Automatic gearbox – Borg-Warner model 66 .....	44
Automatic gearbox – GM 400 .....	44
Propeller and drive shafts .....	47
Final drive .....	51
Steering .....	57
Front suspension .....	60
Rear suspension .....	64
Brakes .....	70
Body .....	76
Body repair .....	77
Heating and ventilation system .....	80
Air conditioning .....	82
Wipers and washers .....	84
Electrical system .....	86
Electrical circuits/bulb and fuse charts .....	86A
Instruments .....	88

# INTRODUCTION

## STANDARDIZED ABBREVIATIONS AND SYMBOLS IN THIS MANUAL

Abbreviation or Symbol	Term	Abbreviation or Symbol	Term
A	Ampere	L.H.Stg	Left-hand steering
A.B.D.C.	After bottom dead centre	L.H. Thd.	Left-hand thread
a.c.	Alternating current	l.t.	Low tension (electrical)
A.F.	Across flats (bolt/nut size)	M	Metric (screw thread)
Ah	Ampere hour	m	Metres
A.T.D.C.	After top dead centre	max.	Maximum
Atm	Atmospheres	MES	Miniature Edison Screw
Auto	Automatic transmission	min.	Minimum
B.A.	British Association (screw thread)	mm	Millimetres
B.B.D.C.	Before bottom dead centre	mmHg	Millimetres of mercury
B.D.C.	Bottom dead centre	m.p.g.	Miles per gallon
b.h.p.	Brake horse-power	m.p.h.	Miles per hour
b.m.e.p.	Brake mean effective pressure	N	Newton
B.S.	British Standards	Nm	Newton metres
B.S.F.	British Standard Fine (screw thread)	No.	Numbers
B.S.P.	British Standard Pipe (thread)	Nox	Oxides of nitrogen
B.S.W.	British Standard Whitworth (screw thread)	N.P.T.F.	American Standard Taper Pipe (thread)
B.T.D.C.	Before top dead centre	O <sub>2</sub>	Oxygen
C	Centigrade (Celsius)	O/D	Overdrive
cm	Centimetres	o.dia.	Outside diameter
cm <sup>2</sup>	Square centimetres	oz	Ounces (mass)
cm <sup>3</sup>	Cubic centimetres	ozf	Ounces (force)
c/min	Cycles per minute	ozf in	Ounces inch (torque)
CO	Carbon monoxide	para.	Paragraph
cwt	Hundredweight	Part no.	Part number
d.c.	Direct current	PAS	Power assisted steering
deg.	Degree (angle or temperature)	pt	Imperial pints
dia.	Diameter	r	Radius
DIN	Deutsche Industrie Norm (Standard)	ref.	Reference
E.C.U.	Electronic Control Unit	rev/min	Revolutions per minute
E.G.R.	Exhaust Gas Recirculation	R.H.	Right-hand
F	Fahrenheit	R.H.Stg.	Right-hand steering
F.I.	Fuel Injection	S.A.E.	Society of Automotive Engineers
Fig	Figure (illustration)	S.C.	Single carburettors
ft	Feet	sp. gr.	Specific gravity
ft/min	Feet per minute	Std.	Standard
g	Grammes (mass)	s.w.g.	Standard wire gauge
gal	Imperial gallons	Synchro	Synchronizer
gf	Grammes (force)		Synchromesh
h.c.	High compression	T.C.	Twin carburettors
hp	Horse-power	T.D.C.	Top dead centre
h.t.	High tension (electrical)	t.p.i.	Threads per inch
i.dia.	Internal diameter	U.N.C.	Unified Coarse (screw thread)
i.f.s.	Independent front suspension	U.N.F.	Unified Fine (screw thread)
in	Inches	U.K.	United Kingdom
in <sup>2</sup>	Square Inches	U.S. gal	Gallons (US)
in <sup>3</sup>	Cubic inches	U.S. pt	Pints (US)
inHg	Inches of mercury	V	Volts
kg	Kilogrammes (mass)	W	Watts
kgf/cm <sup>2</sup>	Kilogrammes per square centimetre	1st	First
kgf m	Kilogrammes metres	2nd	Second
km	Kilometres	3rd	Third
km/h	Kilometres per hour	4th	Fourth
kPa	Kilopascals	5th	Fifth
k.p.i.	King pin inclination	°	Degree (angle or temperature)
kV	Kilovolts	∞	Infinity
kW	Kilowatts	'	Minute (angle)
lb	Pounds (mass)	-	Minus (tolerance)
lbf	Pounds (force)	%	Percentage
lbf ft	Pounds feet (torque)	+	Plus (tolerance)
lbf/ft <sup>2</sup>	Pounds per square foot	+ ve	Positive (electrical)
lbf in	Pounds inches (torque)	- ve	Negative (electrical)
lbf/in <sup>2</sup>	Pounds per square inch	±	Plus or minus (tolerance)
l.c.	Low compression	"	Second (angle)
L.H.	Left-hand	Ω	Ohms

**ENGINE DATA — 3.4 LITRE**

<b>General Data</b>	Number of cylinders .....	6 (in line)	
	Bore .....	83,0 mm	3.2677 in
	Stroke .....	106,0 mm	4.1732 in
	Cubic capacity .....	3441,2 cm <sup>3</sup>	210 in <sup>3</sup>
<b>Cylinder Block</b>	Material .....	Chromium cast iron	
	Type of cylinder liner .....	Dry (used for salvage only)	
	Material (liners) .....	Cast iron	
	Liner interference fit .....	0,064 to 0,0114 mm	0.0025 to 0.0045 in
	Bore diameters after honing: Piston Grade .....	Maximum    Minimum	Maximum    Minimum
	F .....	82,997 mm    82,989 mm	3.2676 in    3.2673 in
	G .....	83,007 mm    83,000 mm	3.2680 in    3.2677 in
H .....	83,017 mm    83,010 mm	3.2684 in    3.2681 in	
	Outside diameter of liners .....	86,220 to 86,246 mm	3.3945 to 3.3955 in
	Line bore for main bearings .....	74,08 to 74,09 mm	2.9165 to 2.9170 in
<b>Cylinder Head</b>	Material .....	Aluminium alloy	
	Valve seat angle: Inlet .....	45°	
	Exhaust .....	45°	
<b>Crankshaft</b>	Material .....	BS 970-709M 40/T (EN 19 T) or BS 970-605M 36/T (EN 16 T)	
	Number of main bearings .....	7	
	Main bearing type .....	Vandervell VP2C	
	Journal diameter .....	69,855 to 69,842 mm	2.7502 to 2.7497 in
	Journal length, over 2,4 mm (0.095 in) radii:		
	Front .....	39,675 ± 0,254 mm	1.562 ± 0.010 in
	Centre .....	34,938 to 34,950 mm	1.3755 to 1.3760 in
	Intermediate .....	30,912 to 31,013 mm	1.217 to 1.221 in
	Rear .....	42,4 mm	1.67 in
	Thrust taken .....	Centre bearing thrust washers	
	Thrust washer thickness .....	2,311 to 2,362 mm or 2,413 to 2,464 mm	0.091 to 0.093 in or 0.095 to 0.097 in
	Permissible end-float .....	0,10 to 0,15 mm	0.004 to 0.006 in
	Width of main bearing: Front .....	34,544 to 34,925 mm	1.360 to 1.375 in
	Centre .....	28,321 to 28,702 mm	1.115 to 1.130 in
	Rear .....	34,544 to 34,925 mm	1.360 to 1.375 in
	Intermediate .....	25,019 to 24,400 mm	0.985 to 1.00 in
	Diametrical clearance .....	0,020 to 0,064 mm	0.0008 to 0.025 in
Crankpins: Diameter .....	52,987 to 52,974 mm	2.0861 to 2.0865 in	
Length .....	30,142 to 30,193 mm	1.1867 to 1.1887 in	
Regrind undersizes .....	0,51 mm	0.020 in	
Minimum diameter for regrind .....	-0,51 mm	-0.020 in	
<b>Connecting Rods</b>	Length between centres .....	196,85 mm	7.75 in
	Big-end bearing type .....	Vandervell VP2C	
	Bore for big-end bearing .....	56,718 to 56,731 mm	2.2330 to 2.2335 in
	Width of big-end bearing .....	24,38 to 24,77 mm	0.960 to 0.975 in
	Big-end diametrical clearance .....	0,025 to 0,069 mm	0.0010 to 0.0027 in
	Big-end side clearance .....	0,132 to 0,234 mm	0.052 to 0.0092 in
	Small-end bush material .....	Vandervell VP10	
	Bore for small-end bush .....	25,387 to 25,413 mm	0.9995 to 1.0005 in
	Width of small-end bush .....	26,92 to 27,43 mm	1.06 to 1.08 in
Bore diameter of small-end bush .....	22,231 to 22,235 mm	0.87525 to 0.87540 in	

## GENERAL SPECIFICATION

<b>Pistons</b>	Type .....	Solid skirt	
	Skirt clearance (measured midway down bore across bottom of piston skirt) .....	0,018 to 0,033 mm	0.0007 to 0.0013 in
<b>Piston Rings</b>	Number of compression rings .....	2	
	Number of oil control rings .....	1	
	Top compression ring width .....	1,562 to 1,588 mm	0.0615 to 0.0625 in
	Second compression ring width .....	1,961 to 1,986 mm	0.0772 to 0.0782 in
	Oil control ring width .....	Self expanding ring	
	Top compression ring thickness .....	3,150 to 3,302 mm	0.124 to 0.130 in
	Second compression ring thickness .....	3,150 to 3,302 mm	0.124 to 0.130 in
	Side clearance of top compression ring in groove .....	0,038 to 0,089 mm	0.0015 to 0.0035 in
	Side clearance of second compression ring in groove .....	0,038 to 0,089 mm	0.0015 to 0.0035 in
	Side clearance of oil control ring in groove .....	Self expanding ring; groove width	
		4,008 to 4,034 mm	0.1578 to 0.1588 in
Top compression ring gap in bore .....	0,33 to 0,46 mm	0.013 to 0.018 in	
Second compression ring gap in bore .....	0,23 to 0,36 mm	0.009 to 0.014 in	
<b>Gudgeon Pins</b>	Type .....	Fully floating	
	Length .....	71,882 to 72,263 mm	2.830 to 2.845 in
	Outside diameter: Marked Red .....	22,228 to 22,230 mm	0.8751 to 0.8752 in
	Marked Green .....	22,225 to 22,228 mm	0.8750 to 0.8751 in
<b>Camshafts</b>	Number of journals .....	4 per shaft	
	Number of bearings .....	4 per shaft (8 half bearings)	
	Type of bearings .....	White metal steel-backed, Vandervell	
	Journal diameter .....	25,375 to 25,387 mm	0.999 to 0.9995 in
	Diametrical clearance .....	0,013 to 0,056 mm	0.0005 to 0.0022 in
Thrust taken .....	Front end shafts		
<b>Valves and Valve Springs</b>	Inlet valve material .....	Silico chrome steel	
	Exhaust valve material .....	Austenitic steel	
	Inlet valve head diameter .....	44,32 to 44,58 mm	1.745 to 1.755 in
	Exhaust valve head diameter .....	41,15 to 41,40 mm	1.620 to 1.630 in
	Valve stem diameter: Inlet and exhaust .....	7,87 to 7,94 mm	0.310 to 0.3125 in
	Valve lift .....	9,53 mm	0.375 in
	Inlet valve clearance .....	0,305 to 0,356 mm	0.012 to 0.014 in
	Exhaust valve clearance .....	0,305 to 0,356 mm	0.012 to 0.014 in
	Outer valve spring free length .....	53,42 mm	2.103 in
	Inner valve spring free length .....	44,04 mm	1.734 in
<b>Valve Guides and Seats</b>	Valve guide material .....	Cast iron (Brico Alloy 2 or BS. 1452/12)	
	Inlet valve guide length .....	47,24 mm	1.86 in
	Exhaust valve guide length .....	49,53 mm	1.95 in
	Outside diameter (both guides):		
	Standard .....	12,725 to 12,751 mm	0.501 to 0.502 in
	First oversize .....	12,776 to 12,802 mm	0.503 to 0.504 in
	Second oversize .....	12,852 to 12,878 mm	0.506 to 0.507 in
	Third oversize .....	12,979 to 13,005 mm	0.511 to 0.512 in
	Interference fit in cylinder head .....	0,013 to 0,056 mm	0.0005 to 0.0022 in
	Valve seat material .....	Sintered iron (Brico AO25/M)	
	Inlet valve seat outside diameter: Standard .....	47,041 to 47,054 mm	1.852 to 1.8525 in
	Interference fit in cylinder head .....	0,0762 mm	0.003 in
	Exhaust valve seat outside diameter: Standard .....	43,066 to 43,078 mm	1.6955 to 1.6960 in
Interference fit in cylinder head .....	0,0762 mm	0.003 in	
<b>Tappets</b>	Tappet material .....	Chilled cast iron	
	Outside diameter of tappet .....	34,895 to 34,905 mm	1.3738 to 1.3742 in
	Tappet guide interference fit .....	0,185 to 0,221 mm	0.0073 to 0.0087 in
	Diametrical clearance of tappet in guide .....	0,020 to 0,048 mm	0.0008 to 0.0019 in

<b>Lubricating System</b>	Oil pump .....	Hobourn-Eaton rotor-type	
	Oil filter .....	Full-flow, renewable element or disposable canister	
<b>Timing Chains and Sprockets</b>	Type .....	Duplex	
	Pitch .....	9,5 mm	$\frac{3}{8}$ in
	Number of pitches: Lower chain .....	82	
	Upper chain .....	100	
	Crankshaft sprocket: Teeth .....	21	
	Intermediate sprocket (outer): Teeth .....	28	
	Intermediate sprocket (inner): Teeth .....	20	
	Camshaft sprockets: Teeth .....	30	

**4.2 LITRE ENGINE**

<b>General Data</b>	Number of cylinders .....	6 (in line)	
	Bore .....	92,07 mm	3.625 in
	Stroke .....	106 mm	4,173 in
	Cubic capacity .....	4235 cm <sup>3</sup>	258.43 in <sup>3</sup>

<b>Cylinder Block</b>	Material (cylinder block) .....	Chromium cast iron			
	Type of cylinder liner (early cars only) .....	Interference fit, dry liner			
	Material (liners) .....	Brivadium			
	Liner interference fit .....	0,076 to 0,127 mm	0.003 to 0.005 in		
	Bore diameters after honing: Piston Grade .....	Maximum	Minimum	Maximum	Minimum
	F .....	92,083 mm	92,075 mm	3.6253 in	3.6250 in
	G .....	92,093 mm	92,085 mm	3.6257 in	3.6254 in
	H .....	92,103 mm	92,095 mm	3.6261 in	3.6258 in

**NOTE:** 'S' grade pistons are 92,080 to 92,105 mm (3.6252 to 3.6262 in) diameter across bottom of skirt at right angles to gudgeon pins. Honed diameter of bore for these pistons must be 0,018 to 0,033 mm (0.0007 to 0.0013 in) greater than measured diameter of piston at this position.

Outside diameter of liners .....	95,66 mm max. 95,63 mm min.	3.766 in max. 3.765 in min.
Line bore for main bearings .....	74,08 to 74,09 mm	2.9165 to 2.9170 in

<b>Cylinder Head</b>	Material .....	Aluminium alloy
	Valve seat angle: Inlet .....	45°
	Exhaust .....	45°

<b>Crankshaft (C41200)</b>	Material .....	En 16, 18 or 111	
	Number of main bearings .....	7	
	Main bearing type .....	Vandervell VP2C	
	Journal diameter .....	69,85 to 69,86 mm	2.7500 to 2.7505 in
	Journal length (over $\frac{3}{32}$ in radii): Front .....	39,69 ± 0,254 mm	1.562 ± 0.10 in
	Centre .....	34,925 ± $\begin{smallmatrix} 0,025 \\ 0,013 \end{smallmatrix}$ mm	1.375 ± $\begin{smallmatrix} 0,001 \\ 0,0005 \end{smallmatrix}$ in
	Intermediate .....	30,96 ± 0,051 mm	1.2188 ± 0.002 in
	Rear .....	42,86 mm	1.6875 in
	Thrust taken .....	Centre main bearing cap, half washers	
	Thrust washer thickness .....	2,31 to 2,36 mm	0.091 to 0.093 in
	Permissible end-float .....	0,10 to 0.15 mm	0.004 to 0.006 in
	Width of main bearing: Front .....	34,54 to 34,93 mm	1.360 to 1.375 in
	Centre .....	28,32 to 28,70 mm	1.115 to 1.130 in
	Intermediate .....	24,81 to 25,40 mm	0.985 to 1.00 in
	Rear .....	34,54 to 34,93 mm	1.360 to 1.375 in
	Diametrical clearance .....	0,0203 to 0,0635 mm	0.0008 to 0.0025 in
	Crankpins: Diameter .....	52,984 to 53,00 mm	2.0860 to 2.0866 in
	Length .....	30,158 to 30,181 mm	1.1873 to 1.1882 in
	Regrind undersize .....	0,51 mm	0.020 in
	Minimum diameter for regrind .....	- 0,51 mm	- 0.02 in

## GENERAL SPECIFICATION

Crankshaft (EAC 5742)	As (C41200) except:					
	Journal diameter	69,84 mm to 69,85 mm	2.7497 to 2.7502 in			
	Crankpins: Diameter	52,964 mm to 52,976 mm	2.0852 to 2.0857 in			
Connecting Rods	Length between centres	196,85 mm	7.75 in			
	Big-end bearing type	Vandervell VP2C				
	Bore for big-end bearing	56,72 to 56,73 mm	2.2330 to 2.2335 in			
	Width of big-end bearing	24,38 to 24,77 mm	0.960 to 0.975 in			
	Big-end diametrical clearance	0,025 to 0,069 mm	0.0010 to 0.0027 in			
	Big-end side clearance	0,147 to 0,221 mm	0.0058 to 0.0087 in			
	Small-end bush material	Vandervell VP10				
	Bore for small-end bush	25,4 ± 0,013 mm	1.0 ± 0.0005 in			
	Width of small-end bush	26,92 to 27,43 mm	1.060 to 1.080 in			
Bore diameter of small-end bush	22,23 $\begin{smallmatrix} +0,0038 \\ -0,000 \end{smallmatrix}$ mm	0,87525 $\begin{smallmatrix} +0,00015 \\ -0,000 \end{smallmatrix}$ in				
Pistons	Type	Solid skirt				
	Skirt clearance (measured midway down bore across bottom of piston skirt)	0,018 to 0,033 mm	0.0007 to 0.0013 in			
Piston Rings	Number of compression rings	2				
	Number of oil control rings	1				
	Top compression ring width	2 mm nominal	0.0781 in nominal			
	Second compression ring width	2 mm nominal	0.0781 in nominal			
	Oil control ring width	Self expanding				
	Top compression ring thickness	4,35 to 4,60 mm	0.171 to 0.188 in			
	Second compression ring thickness	4,35 to 4,60 mm	0.171 to 0.188 in			
	Side clearance of top compression ring in groove	0,038 to 0,089 mm	0.0015 to 0.0035 in			
	Side clearance of second compression ring in groove	0,038 to 0,089 mm	0.0015 to 0.0035 in			
Prior to Vin No. 8L 103481	<div style="display: inline-block; vertical-align: middle; font-size: 2em;">{</div>	Top compression ring gap in bore	0,38 to 0,51 mm	0.015 to 0.020 in		
		Second compression ring gap in bore	0,23 to 0,35 mm	0.009 to 0.014 in		
		Oil control ring gap in bore	0,38 to 1,14 mm	0.015 to 0.045 in		
		From Vin No. 8L 103481	<div style="display: inline-block; vertical-align: middle; font-size: 2em;">{</div>	Top ring	0,38 to 0,51 mm	0.015 to 0.020 in
				2nd ring	0,41 to 0,66 mm	0.016 to 0.026 in
				Oil control ring	0,31 to 0,61 mm	0.012 to 0.024 in
Gudgeon Pins	Type	Fully-floating				
	Length	75,95 to 76,2 mm	2.990 to 3.000 in			
	Outside diameter: <b>Marked Red</b>		22,228 to 22,230 mm	0.8751 to 0.8752 in		
		<b>Marked Green</b>		22,225 to 22,228 mm	0.8750 to 0.8751 in	
Camshafts	Number of journals	4 per shaft				
	Number of bearings	4 per shaft (8 half bearings)				
	Type of bearings	White metal steel-backed, Vandervell				
	Journal diameter	25,387 to 25,375 mm	0.9995 to 0.9990 in			
	Diametrical clearance	0,013 to 0,051 mm	0.0005 to 0.002 in			
	Thrust taken	Front end of shafts				
Valves and Valve Springs	Inlet valve material	Silico chrome steel				
	Exhaust valve material	Austenitic steel				
	Inlet valve head diameter	47,50 to 47,75 mm	1.870 to 1.880 in			
	Exhaust valve head diameter	41,15 to 41,40 mm	1.620 to 1.630 in			
	Valve stem diameter: Inlet and exhaust	7,87 to 7,94 mm	0.310 to 0.3125 in			
	Valve lift	9,53 mm	0.375 in			
	Inlet valve clearance	0,305 to 0,356 mm	0.012 to 0.014 in			
	Exhaust valve clearance	0,305 to 0,356 mm	0.012 to 0.014 in			
	Outer valve spring free length	49,21 to 50,80	1.938 to 2.00 in			
	Inner valve spring free length	42,07 to 43,66 mm	1.656 to 1.719 in			



4.2 litre (cont)

<b>Valve Guides and Seats</b>	Valve guide material	Cast iron (Brico Alloy 2 or BS. 1452/12)	
	Inlet valve guide length	47,24 mm	1.86 in
	Exhaust valve guide length	49,53 mm	1.95 in
	Outside diameter (both guides):		
	Standard	12,725 to 12,751 mm	0.501 to 0.502 in
	First oversize	12,776 to 12,802 mm	0.503 to 0.504 in
	Second oversize	12,852 to 12,878 mm	0.506 to 0.507 in
	Third oversize	12,979 to 13,005 mm	0.511 to 0.512 in
	Interference fit in cylinder head	0,013 to 0,056 mm	0.0005 to 0.0022 in
	Valve seat material	Sintered iron (Brico AQ25/M)	
	Inlet valve seat outside diameter: Standard	47,041 to 47,054 mm	1.852 to 1.8525 in
	Interference fit in cylinder head	0,0762 mm	0.003 in
	Exhaust valve seat outside diameter: Standard	43,066 to 43,078 mm	1.6955 to 1.6960 in
Interference fit in cylinder head	0,0762 mm	0.003 in	
<b>Tappets</b>	Tappet material	Chilled cast iron	
	Outside diameter of tappet	34,895 to 34,905 mm	1.3738 to 1.3742 in
	Tappet guide interference fit	0,185 to 0,221 mm	0.0073 to 0.0087 in
	Diametrical clearance of tappet in guide	0,020 to 0,048 mm	0.0008 to 0.0019 in
<b>Lubricating System</b>	Oil pump	Hoboum-Eaton rotor-type	
	Oil filter	Full-flow, renewable element	
	Min pressure — hot @ 3000 rev/min	2,8 kg/cm <sup>2</sup>	40 lb/in <sup>2</sup>
<b>Timing Chains and Sprockets</b>	Type	Duplex	
	Pitch	9,5 mm	3/8 in
	Number of pitches: Lower chain	82	
	Upper chain	100	
	Crankshaft sprocket: Teeth	21	
	Intermediate sprocket (outer): Teeth	28	
	Intermediate sprocket (inner): Teeth	20	
	Camshaft sprockets: Teeth	30	

**ENGINE DATA — 5.3 LITRE**

<b>General Data</b>	Number of cylinders	12	
	Stroke	70 mm	2.756 in
	Bore	90 mm	3.543 in
	Cubic capacity	5343 cm <sup>3</sup>	326.0 in <sup>3</sup>
	Ignition timing: Initial static setting, to start engine only		
	'A' Emission spec.	9° ± 1° B.T.D.C.	
	'B' Emission spec.	4° ± 1° B.T.D.C.	

## GENERAL SPECIFICATION

<b>Cylinder Block</b>	Material (cylinder block) .....	Aluminium alloy	
	Angle of cylinders .....	60° Vee	
	Type of cylinder liner .....	Slip fit, wet liner	
	Material (liners) .....	Cast iron	
	Nominal size of bore after honing:		
	Grade 'A'—Red .....	89,98 mm	3.543 in
	Grade 'B'—Green .....	90,01 mm	3.544 in
	Outside diameter of liner—both grades .....	97,99 mm + 0.02 mm -0.00 mm	3.858 in + 0.001 in -0.00 in
	Main line bore for main bearings .....	80,429 to 80,434 mm	3.1665 to 3.1667 in
	<b>Cylinder Heads</b>	Material .....	Aluminium alloy
Valve seat angle: Inlet .....		44½°	
Exhaust .....		44½°	
<b>Crankshaft</b>	Material .....	Manganese molybdenum steel	
	Number of main bearings .....	7	
	Main bearing type .....	Vandervell V.P.3	
	Journal diameter .....	76,218 to 76,231 mm	3.0007 to 3.0012 in)
	Journal length: Front .....	29,72 to 29,97 mm	1.170 to 1.180 in
	Centre .....	36,20 to 36,22 mm	1.425 to 1.426 in
	Intermediate .....	30,43 to 30,53 mm	1.198 to 1.202 in
	Rear .....	36,20 to 36,22 mm	1.425 to 1.426 in
	Thrust taken .....	Centre bearing thrust washers	
	Thrust washer thickness .....	2,57 to 2,62 mm	0.101 to 0.103 in
	Permissible end-float .....	0,10 to 0,28 mm	0.004 to 0.011 in
	Width of main bearing: Front .....	24,40 to 24,65 mm	0.963 to 0.973 in
	Centre .....	30,2 to 30,5 mm	1.190 to 1.200 in
	Intermediate .....	24,40 to 24,65 mm	0.963 to 0.973 in
	Rear .....	30,2 to 30,5 mm	1.190 to 1.200 in
	Diametrical clearance: all bearings .....	0,04 to 0,07 mm	0.0015 to 0.003 in
	Crankpin diameter .....	58,40 to 58,42 mm	2.2994 to 2.3000 in
	Crankpin length .....	43,15 to 43,20 mm	1.699 to 1.701 in
	<b>Connecting Rods</b>	Length between centres .....	151,4 mm +0,12 mm -0,00 mm
Big-end bearing material .....		VP2C	
Bore for big-end bearing .....		62,0 mm +0,15 mm -0,00 mm	2.441 in +0.006 in -0.000 in
Width of big-end bearing .....		18,3 to 18,5 mm	0.720 to 0.730 in
Big-end diametrical clearance .....		0,04 to 0,09 mm	0.0015 to 0.0034 in
Big-end side clearance .....		0,17 to 0,33 mm	0.007 to 0.013 in
Small-end bush material .....		VP.10.	
Bore for small-end bush .....		26,98 mm +0,025 mm -0,00 mm	1.062 in +0.001 in -0.000 in.
Width of small-end bush .....		26,2 to 26,7 mm	1.03 to 1.05 in
Bore diameter of small-end bush .....		23,813 to 23,818 mm	0.9375 to 0.9377 in
<b>Pistons</b>		Type .....	Solid skirt
	Skirt clearance (measured midway down bore across bottom of piston skirt) .....	0,03 to 0,04 mm	0.0012 to 0.0017 in
<b>Piston Rings</b>	Number of compression rings .....	2	
	Number of oil control rings .....	1	
	Top compression ring thickness .....	3,81 to 4,06 mm	0.150 to 0.160 in
	Second compression ring thickness .....	3,81 to 4,06 mm	0.150 to 0.160 in
	Oil control ring width .....	Self expanding	
	Width of oil control ring rails .....	2,62 ± 0,07 mm	0.103 ± 0.003 in
	Top compression ring width .....	1,58 to 1,60 mm	0.062 to 0.063 in
	Second compression ring width .....	1,96 to 1,98 mm	0.077 to 0.078 in
	Side clearance of top compression ring in groove ...	0,07 mm	0.0029 in
	Side clearance of second compression ring in groove ...	0,09 mm	0.0034 in
	Side clearance of oil control rings in groove .....	0,14 to 0,17 mm	0.0055 to 0.0065 in
	Top compression ring gap in bore .....	0,36 to 0,51 mm	0.014 to 0.020 in
	Second compression ring gap in bore .....	0,25 to 0,38 mm	0.010 to 0.015 in
Gap of oil control ring rails in bore .....	0,38 to 1,14 mm	0.015 to 0.045 in	

## GENERAL SPECIFICATION

<b>Gudgeon Pins</b>	Type .....	Fully floating		
	Length .....	79,25 to 79,38 mm	3.120 to 3.125 in	
	Outside diameter: Grade 'A' Red .....	23,81 mm	0.9375 in	
		Grade 'B' Green .....	23,76 mm	0.9373 in
<b>Camshafts</b>	Number of journals .....	7 per shaft		
	Number of bearings .....	7 per shaft (14 half bearings)		
	Type of bearings .....	Aluminium alloy—camshafts run direct in caps and tappet block		
	Journal diameter: All journals .....	26,93 mm +0.013 mm -0,000 mm	1.0615 in +0.0005 -0.000 in	
	Diametrical clearance .....	0,03 to 0,07 mm	0.001 to 0.003 in	
	Thrust taken .....	Front end of shafts		
<b>Jackshaft</b>	Number of bearings .....	3		
	Diametrical clearance in block .....	0,013 to 0,076 mm	0.0005 to 0.0003 in	
	Thrust taken .....	Front end of shaft		
	Permissible end-float .....	0,13 mm	0.005 in	
	Line bore of front bearing .....	31,78 to 31,80 mm	1.251 to 1.252 in	
	Line bore of centre and rear bearing .....	30,23 to 30,25 mm	1.190 to 1.191 in	
<b>Valves and Valve Springs</b>	Inlet valve material .....	Silico chrome steel		
	Exhaust valve material .....	Austenitic steel		
	Inlet valve head diameter (except HE) .....	41,22 to 41,32 mm	1.623 to 1.627 in	
	Inlet valve head diameter HE .....	41,15 to 41,40 mm	1.620 to 1.630 in	
	Exhaust valve head diameter (except HE) .....	34,5 to 34,6 mm	1.358 to 1.362 in	
	Exhaust valve head diameter HE .....	34,32 to 34,6 mm	1.355 to 1.365 in	
	Valve stem diameter: Inlet and exhaust .....	7,854 to 7,866 mm	0.3092 to 0.3093 in	
	Valve lift .....	9,5 mm	0.375 in	
	Inlet valve clearance (except HE) .....	0,305 to 0,356 mm	0.012 to 0.014 in	
	Inlet valve clearance HE .....	0,254 to 0,305 mm	0.010 to 0.012 in	
	Exhaust valve clearance (except HE) .....	0,305 to 0,356 mm	0.012 to 0.014 in	
	Exhaust valve clearance HE .....	0,254 to 0,305 mm	0.010 to 0.012 in	
	Outer valve spring free length .....	53,4 mm	2.103 in	
Inner valve spring free length .....	44,0 mm	1.734 in		
<b>Valve Guides and Seats</b>	Valve guide material .....	Cast iron		
	Inlet valve guide length .....	48,5 mm	1.910 in	
	Exhaust valve guide length (except HE) .....	54,0 mm	2.125 in	
	Exhaust valve guide length HE .....	43,82 mm	1.725 in	
	Inlet valve guide outside diameter .....	As exhaust valve guide		
	Exhaust valve guide outside diameter:			
	Standard .....	12,75 to 12,72 mm	0.502 to 0.501 in	
	First oversize (2 grooves) .....	12,88 to 12,85 mm	0.507 to 0.506 in	
	Second oversize (3 grooves) .....	13,01 to 12,98 mm	0.512 to 0.511 in	
	Inlet valve guide finished bore .....	7,90 to 7,92 mm	0.311 to 0.312 in	
	Exhaust valve guide finished bore .....	7,90 to 7,92 mm	0.311 to 0.312 in	
	Maximum clearance between valve stem and guide ..	0,05 to 0,06 mm	0.0020 to 0.0023 in	
	Interference fit in cylinder head .....	0,05 to 0,15 mm	0.002 to 0.006 in	
Valve seat insert material .....	Sintered iron			
<b>Service Replacements</b>	Inlet valve seat insert outside diameter (except HE) ..	44,30 mm $\begin{smallmatrix} +0,01 \\ -0,00 \end{smallmatrix}$ mm	1.744 in $\begin{smallmatrix} +0,0005 \\ -0,0000 \end{smallmatrix}$ in	
	Inlet valve seat insert HE diameter .....	42,93 mm $\begin{smallmatrix} +0,01 \\ -0,00 \end{smallmatrix}$ mm	1.6901 in $\begin{smallmatrix} +0,0005 \\ -0,0000 \end{smallmatrix}$ in	
	Exhaust valve seat insert outside diameter .....	38,17 mm $\begin{smallmatrix} +0,01 \\ -0,00 \end{smallmatrix}$ mm	1.503 in $\begin{smallmatrix} +0,0005 \\ -0,0000 \end{smallmatrix}$ in	
	Inlet valve seat inside diameter (except HE) .....	35,56 mm $\begin{smallmatrix} +0,17 \\ -0,00 \end{smallmatrix}$ mm to	1.400 in $\begin{smallmatrix} +0,003 \\ -0,0000 \end{smallmatrix}$ in to	
		39,74 mm $\begin{smallmatrix} +0,25 \\ -0,00 \end{smallmatrix}$ mm	1.565 in $\begin{smallmatrix} +0,010 \\ -0,0000 \end{smallmatrix}$ in	
	Inlet valve seat inside diameter HE .....	35,56 mm $\begin{smallmatrix} +0,17 \\ -0,00 \end{smallmatrix}$ mm to	1.400 in $\begin{smallmatrix} +0,0005 \\ -0,0000 \end{smallmatrix}$ in	
		39,95 mm $\begin{smallmatrix} +0,25 \\ -0,00 \end{smallmatrix}$ mm	1.573 in $\begin{smallmatrix} +0,010 \\ -0,0000 \end{smallmatrix}$ in	
	Exhaust valve seat inside diameter (except HE) .....	30,1 mm $\begin{smallmatrix} +0,07 \\ -0,00 \end{smallmatrix}$ mm to	1.185 in $\begin{smallmatrix} +0,003 \\ -0,0000 \end{smallmatrix}$ in to	
		33,4 mm $\begin{smallmatrix} +0,12 \\ -0,00 \end{smallmatrix}$ mm	1.315 in $\begin{smallmatrix} +0,006 \\ -0,0000 \end{smallmatrix}$ in	
	Exhaust valve seat inside diameter HE .....	30,45 mm $\begin{smallmatrix} +0,07 \\ -0,00 \end{smallmatrix}$ mm to	1.199 in $\begin{smallmatrix} +0,003 \\ -0,0000 \end{smallmatrix}$ in to	
		33,51 mm $\begin{smallmatrix} +0,25 \\ -0,00 \end{smallmatrix}$ mm	1.280 in $\begin{smallmatrix} +0,010 \\ -0,0000 \end{smallmatrix}$ in	
	<b>Tappets and Tappet Guides</b>	Tappet material .....	Cast iron (chilled)	
		Outside diameter of tappet .....	34,87 to 34,90 mm	1.373 to 1.374 in
Diametrical clearance .....		0,02 to 0,04 mm	0.001 to 0.002 in	

## GENERAL SPECIFICATION

<b>Lubricating System</b>	Oil pump .....	Epicyclic gear type	
	Oil pump gears:		
	Driving gear outside diameter:		
	Diametrical clearance .....	0,127 to 0,305 mm	0.005 to 0.012 in
	Radial clearance .....	0,065 to 0,152 mm	0.0025 to 0.006 in
	Driven gear outside diameter:		
	Diametrical clearance .....	0,178 to 0,254 mm	0.007 to 0.010 in
	Radial clearance .....	0,09 to 0,13 mm	0.0035 to 0.005 in
	Driven gear internal diameter:		
	Diametrical clearance .....	0,28 to 0,46 mm	0.011 to 0.018 in
	Radial clearance .....	0,14 to 0,23 mm	0.0055 to 0.009 in
Side clearance: driving and driven gear .....	0,115 to 0,165 mm	0.0045 to 0.0065 in	
Oil filter type .....	Full flow, disposable canister		
Oil pressure min. @ 3000 rev/min .....	2,8 kg/cm <sup>2</sup>	40 lb/in <sup>2</sup>	
<b>Timing Chain and Sprockets</b>	Type of chain .....	Duplex endless	
	Pitch .....	9,5 mm	0.375 in
	Number of pitches .....	180	
	Camshaft sprockets: Number of teeth (each) .....	42	
	Crankshaft sprocket: Number of teeth .....	21	
	Jackshaft sprocket: Number of teeth .....	21	

## TORQUE WRENCH SETTINGS

For the Torque wrench settings refer to the front of the relevant section.

**GENERAL SPECIFICATION DATA—6 Cylinder Cars**

<b>Engine</b>	See Engine Tuning Data	Section 05
<b>Final Drive Unit</b>	Type	Hypoid with normal differential; Powr Lok differential available as optional extra
	Pre 1982 MY Ratio: Standard	3.31:1 (43/13)
	1982 MY on Alternative	3.07:1 (43/14)
<b>Final Drive Ratios—1982 MY cars</b>	3.4L— all cars	3.54:1 (46/13)
	4.2L— manual transmission cars	3.31:1 (43/13)
	4.2L— automatic transmission cars — not NAS	3.058:1 (52/17) Vin. 326917
	4.2L— automatic transmission cars — NAS only	2.88:1 (49/17) 1982 model year
<b>Automatic Gearbox</b>	Make and type	Borg-Warner Model 66
	Ratios: First gear	2.39 :1
	Second gear	1.45 :1
	Third gear	1.00 :1
	Reverse	2.09 :1
	Torque converter	2.3 :1 maximum
<b>Manual Gearbox</b>	Type	Five speed with baulk-ring synchromesh on all forward gears
	Ratios: First gear	3.321 :1
	Second gear	2.087 :1
	Third gear	1.396 :1
	Fourth gear	1.0 :1
	Fifth gear	0.883 :1
	Reverse	3.428 :1
<b>Cooling System</b>	Water pump: Type	Centrifugal
	Drive	Belt
	Number of cooling fans	One 12 bladed, driven through Holset coupling
	Cooling system and control	Thermostat
	Auxiliary cooling—certain markets	1 or 2 electric fans blowing air through radiator; controlled by a sensor in the radiator
	Thermostat opening temperature	88°C 190°F
	Filler cap: Pressure rating	1.05 kgf/cm <sup>2</sup> 15 lbf/in <sup>2</sup>
	Make	A.C. Delco
<b>Fuel Injection Equipment 'A' Emissions—4.2 litre cars for North American and Japanese Markets</b>		
	Make and type	Lucas/Bosch Jetronic 'L'
	Airflow meter reference number	73172A
	Extra air valve reference number	73174A
	Deceleration valve reference number	54739484A
	Electronic control unit reference number	83524A
<b>Fuel Injection Equipment 'B' Emissions—4.2 litre cars for all markets except North America and Japan</b>		
	Make and type	Lucas/Bosch Jetronic 'L'
	Airflow meter reference number	73171A
	Extra air valve reference number	73193A
	Deceleration valve reference number	54739875
	Vacuum switch reference number	175-549A
	Electronic control unit reference number	83525A
<b>Fuel System Pumps</b>	Make and type: 3.4 litre carburetter cars	Electrical, two A.C. Delco 'Vega' submerged
	4.2 litre cars	Electrical, Lucas 73175A roller cell pump with integral relief valve and non-return valve

## GENERAL SPECIFICATION DATA—6 Cylinder Cars

<b>Braking System</b>	Front brakes, make and type .....	Girling; ventilated discs, bridge-type calipers	
	Rear brakes, make and type .....	Girling; damped discs, bridge-type calipers incorporating handbrake friction pads	
	Handbrake: Type .....	Mechanical, operating on rear discs	
	Disc diameter: Front .....	284 mm	11.18 in
	Rear .....	263,5 mm	10.375 in
	Disc thickness: Front .....	24,13 mm	0.95 in
	Rear .....	12,7 mm	0.50 in
	Master cylinder bore diameter .....	22,23 mm	0.875 in
	Brake operation .....	Hydraulic	
	Hydraulic fluid .....	Castrol/Girling Universal Brake and Clutch Fluid—exceeding specification S.A.E. J. 1703/D	
	Main brake friction pad material .....	Ferodo 2430 slotted	
	Hand brake friction pad material .....	Mintex M.68/1	
	Servo unit refs.: R.H.D. cars .....	Girling 64049669	
	L.H.D. cars .....	Girling 64049668	
<b>Front Suspension</b>	Type .....	Independent coil spring	
	Castor angle .....	$2\frac{1}{4}^{\circ} \pm \frac{1}{4}^{\circ}$ positive	
	Camber angle .....	$\frac{1}{2}^{\circ} \pm \frac{1}{4}^{\circ}$ negative	
	Front wheel alignment .....	0 mm to 3,2 mm toe in	0 in to $\frac{1}{8}$ in toe in
	Dampers .....	Telescopic, gas filled	
<b>Rear Suspension</b>	Type .....	Independent coil springs, co-axial with dampers	
	Camber angle .....	$\frac{3}{4}^{\circ} \pm \frac{1}{4}^{\circ}$ negative	
	Rear wheel alignment .....	Parallel $\pm$ 0,08 mm	Parallel $\pm$ $\frac{1}{32}$ in
	Dampers .....	Telescopic, gas filled	
<b>Power Assisted Steering</b>	Type .....	Rack and pinion	
	Number of turns lock to lock .....	2.87	
	Turning circle, wall to wall .....	12,85 m	42 ft
<b>Electrical Equipment</b>			
	<b>Battery</b>		
	Make .....	Lucas, chloride or Delco Remy	
	Voltage .....	12V	
<b>Alternator</b>	Make and type: All air-conditioned cars .....	Lucas 25ACR or Motorola 9AR 25 12P	
	Non air-conditioned cars .....	Lucas 18ACR	
	Nominal voltage .....	12V	
	Cut-in voltage .....	13.5V at 2100 rev/min (Motorola 14V at 1050 rev/min)	
	Earth polarity .....	Negative	
	Maximum output .....	18ACR	45A
		25ACR	66A
		Motorola	70A
	Maximum operating speed .....	12 400 rev/min	
	Rotor winding resistance .....	3.2 ohms (18ACR) at 20°C	
		3.6 ohms (25ACR)	
	Brush spring pressure .....	9 to 13 ozf	
	Make and type .....	Lucas A133	
	Maximum output .....	65A — 6 Cyl. non air cond. cars	
		75A — 6 Cyl. air cond. cars and all 12 Cyl. cars	
	Regulator controlled voltage .....	13.6-14.4V (measured across battery)	
	Maximum operating speed .....	15,000 rev/min	
New brush length .....	20 mm (0.8 in)		
Renew at .....	10 mm (0.4 in)		
Brush spring pressure .....	4.7-9.8 oz		
<b>Starter Motor</b>	Make and type .....	Lucas 3M100 pre-engaged	
	Lock torque at 940 amps .....	4,01 kgf m	29 lbf ft
	Torque at 1000 rev/min at 535 amps .....	1,80 kgf m	13 lbf ft
	Light running current .....	100A at 5 000 to 6 000 rev/min	

## GENERAL SPECIFICATION DATA—12 Cylinder Cars

<b>Windscreen Wiper Motor</b>	Make and type .....	Lucas 16W
	Light running speed, rack disconnected (after 60 seconds from cold) .....	Normal: 46 to 52 rev/min; high: 60 to 70 rev/min
	Light running current (after 60 seconds from cold) ...	Normal: 1.5A; high: 2.0A

### GENERAL SPECIFICATION DATA—12 Cylinder Cars

<b>Engine</b>	See Engine Tuning Data .....	Section 05										
<b>Final Drive Unit</b>	Type .....	Hypoid with Powr Lok differential										
	Ratio: Standard Non HE .....	3.07:1 (43/14)										
	HE Onwards .....	2.88:1 (49/17)										
	Alternative .....	3.31:1 (43/13) Australia										
<b>Automatic Gearbox</b>	Make and type .....	General Motors GM 400										
	Ratios: First gear .....	2.48 : 1										
	Second gear .....	1.48 : 1										
	Third gear .....	1.00 : 1										
	Reverse .....	2.07 : 1										
	Torque converter .....	2.00 : 1										
<b>Cooling System</b>	Water pump: Type .....	Centrifugal, with two outlets										
	Drive .....	Belt driven from crankshaft										
	No. of cooling fans .....	Two (1 12-bladed, belt-driven through Holset coupling, plus 1 4-bladed electrically driven, thermostatically controlled)										
	Cooling system control .....	2 thermostats										
	Thermostat opening temperature .....	88°C <span style="float: right;">190°F</span>										
	Thermostat fully open temperature .....	93.5° to 96°C <span style="float: right;">200° to 205°F</span>										
	Filler cap pressure rating .....	1.05 kgf/cm <sup>2</sup> <span style="float: right;">15 lbf/in<sup>2</sup></span>										
	Filler cap make .....	A.C. Delco										
<b>Fuel Injection Equipment</b>	Make and type:											
	N.A.S., U.K. and European markets .....	Lucas Digital 'P', pressure sensing										
Japanese and Australian markets .....	Lucas/Bosch Jetronic D											
		<table border="0" style="width: 100%; border-collapse: collapse;"> <tr> <td style="width: 25%;"></td> <td style="width: 25%; text-align: center;"><b>'A' Emissions</b></td> <td style="width: 25%; text-align: center;"><b>'A' Emissions</b></td> <td style="width: 25%; text-align: center;"><b>'B' Emissions</b></td> <td style="width: 25%; text-align: center;"><b>'D' Emissions</b></td> </tr> <tr> <td></td> <td style="text-align: center;">N.A.S. only</td> <td style="text-align: center;">Japan only</td> <td style="text-align: center;">U.K./Europe</td> <td style="text-align: center;">Australia only</td> </tr> </table>		<b>'A' Emissions</b>	<b>'A' Emissions</b>	<b>'B' Emissions</b>	<b>'D' Emissions</b>		N.A.S. only	Japan only	U.K./Europe	Australia only
	<b>'A' Emissions</b>	<b>'A' Emissions</b>	<b>'B' Emissions</b>	<b>'D' Emissions</b>								
	N.A.S. only	Japan only	U.K./Europe	Australia only								
Injector reference no. ....	Lucas 73178A	Lucas 73143B	Lucas 73178A	Lucas 73143B								
Cold start injector—reference no. ....	Lucas 73180A	Lucas 73160A	Lucas 73180A	Lucas 73147A								
Pressure regulator—reference no. ....	Lucas 73177A	Lucas 73146A	Lucas 73177A	Lucas 73146A								
Throttle switch—reference no. ....	Lucas type 193SA	Lucas 30625A	Lucas type 193SA	Lucas 30625A								
Water temperature sensor—reference no. ....	Lucas 73170A	Lucas 73142A	Lucas 73170A	Lucas 73142A								
Air temperature sensor—reference no. ....	Lucas 73197A	Lucas 73141A	Lucas 73197A	Lucas 73141A								
Thermotime switch—reference no. ....	Lucas 33704A	Lucas 30491A	Lucas 33704A	Lucas 30491A								
Extra air valve—reference no.—all markets .....	Lucas 73192A											
Deceleration valve—reference no. ....	Lucas 73156A	—	—	Lucas 73156A								
Supplementary air valve—reference no. ....	—	—	Tecalemit TDA832	—								
Full throttle micro-switch—reference no. ....	Burgess YBFYR1	—	—	—								
Electrical control unit—reference no. ....	Lucas 83622A	Lucas 83477B	Lucas 83632A	Lucas 83546A								
E.G.R. control unit—reference no. ....	—	Lucas 73158B	—	Lucas 73158B								
Lambda sensors—reference no. ....	Lucas 73199A	—	—	—								
Pressure sensor—reference no. ....	—	Lucas 73164A	—	Lucas 73164A								
Power resistor—reference no. ....	Lucas 73196A	—	Lucas 73196A	—								
Power amplifier—reference no. ....	—	Lucas 83486A	—	Lucas 88486A								
<b>Fuel System Pump</b>	Make and type .....	Lucas 73175A — Electrical roller cell pump with integral relief valve and non-return valve.										

## GENERAL SPECIFICATION DATA—12 Cylinder Cars

<b>Braking System</b>	Front brakes: Make and type .....	Girling; ventilated discs, bridge-type calipers		
	Rear brakes: Make and type .....	Girling; damped discs, bridge-type calipers incorporating handbrake friction pads		
	Handbrake: Type .....	Mechanical, operating on rear discs		
	Disc diameter: Front .....	284 mm	11.18 in	
	Rear .....	263,5 mm	10.375 in	
	Disc thickness: Front .....	24,13 mm	0.95 in	
	Rear .....	12,7 mm	0.50 in	
	Master cylinder bore diameter .....	22,23 mm	0.875 in	
	Brake operation .....	Hydraulic		
	Hydraulic fluid .....	Castrol/Girling Universal Brake and Clutch Fluid—exceeding specification S.A.E. J. 1703/D		
	Main brake friction pad material .....	Ferodo 2430 slotted		
	Hand brake friction pad material .....	Mintex M68/1		
	<b>Front Suspension</b>	Servo unit refs.: L.H.D. ....	Girling 64049668	
R.H.D. ....		Girling 64049670		
Type .....		Independent coil spring		
Castor angle .....		$3\frac{1}{2}^{\circ} \pm \frac{1}{4}^{\circ}$ positive		
Camber angle .....		$\frac{1}{2}^{\circ} \pm \frac{1}{4}^{\circ}$ negative		
Front wheel alignment .....		0 mm to 3,2 mm toe in	0 to $\frac{1}{8}$ in toe in	
Dampers .....		Telescopic, gas filled		
<b>Rear Suspension</b>		Type .....	Independent, coil springs, co-axial with dampers	
		Camber angle .....	$3\frac{1}{4}^{\circ} \pm \frac{1}{4}^{\circ}$ negative	
		Rear wheel alignment .....	Parallel $\pm 0,08$ mm	Parallel $\pm \frac{1}{32}$ in
		Dampers .....	Telescopic, gas filled	
<b>Power Assisted Steering</b>		Type .....	Rack and pinion	
		Number of turns lock to lock .....	2.75	
	Turning circle, wall to wall .....	13,5 m	44 ft	
<b>Electrical Equipment</b>				
<b>Battery</b>	Make and type .....	Lucas, chloride or AC Delco		
<b>Alternator</b>	Make and type .....	Lucas 25ACR or Motorola 9AR2533P		
	Nominal voltage .....	12V		
	Cut-in voltage .....	13.5V at 1500 rev/min (Motorola 14V at 1100 rev/min)		
	Polarity .....	Negative earth		
	Maximum output .....	66A (Motorola 70A)		
	Maximum operating speed .....	15 000 rev/min		
	Rotor winding resistance .....	3.6 ohms at 20°C		
	Brush spring pressure .....	255 to 369 gf	9 to 13 ozf	
<b>Starter Motor</b>	Make and type .....	Lucas M45 pre-engaged		
	Lock torque (at 940 amps) .....	4,01 kgf m	29 lbf ft	
	Torque at 1000 rev/min (at 535 amps) .....	1,80 kgf m	13 lbf ft	
	Light running current .....	100A at 5000 to 6000 rev/min		
<b>Wiper motor</b>	Make and type .....	Lucas 16W		
	Light running speed, rack disconnected (after 60 seconds from cold) .....	Normal: 46 to 52 rev/min, high: 60 to 70 rev/		
	Light running current (after 60 seconds from cold) .....	Normal: 1.5A; high: 2.0A		



**BULB CHART — 6 cyl. & 12 cyl. vehicles**

See Section 86A for bulb charts

## GENERAL SPECIFICATION DATA — 6 & 12 Cylinder Cars

### TYRE DATA

Fitted as complete sets only

Type: 6 cylinder cars .....	Dunlop ER70 VR 15 Sport or Pirelli Cinturato P5 205/70 VR 15
12 cylinder cars .....	Dunlop 205/70 VR 15 D1 SP Sport Super or Pirelli Cinturato P5 205/70 VR15
from Sept. 83	Pirelli Cinturato 215/70 VR 15; Dunlop 215/70 VR 15 D7 Sport Super

### PRESSURE:

#### All Series III 6 cyl. Engined Saloons

	Front	Rear
For speeds above 100 mph (160 km/h) with driver and two passengers	2.27 bar 2.32 kgf/cm <sup>2</sup> 33 lbf/in <sup>2</sup>	2.21 bar 2.25 kgf/cm <sup>2</sup> 32 lbf/in <sup>2</sup>
For speeds above 100 mph with full load (including luggage) of 410 kg (904 lb)	2.27 bar 2.32 kgf/cm <sup>2</sup> 33 lbf/in <sup>2</sup>	2.48 bar 2.53 kgf/cm <sup>2</sup> 36 lbf/in <sup>2</sup>

The above pressures may also be reduced by 0.41 bar; 0.42 kgf/cm<sup>2</sup>; (6 lbf/in<sup>2</sup>) on the front and rear tyres to obtain maximum comfort, provided the speed does not exceed 100 mph (160 km/h).

#### All Series III 12 cyl. Engined Saloons

	Front	Rear
For speeds above 100 mph (160 km/h) with driver and two passengers	2.48 bar 2.53 kgf/cm <sup>2</sup> 36 lbf/in <sup>2</sup>	2.21 bar 2.25 kgf/cm <sup>2</sup> 32 lbf/in <sup>2</sup>
For speeds above 100 mph with full load (including luggage) of 410 kg (904 lb)	2.48 bar 2.53 kgf/cm <sup>2</sup> 36 lbf/in <sup>2</sup>	2.48 bar 2.53 kgf/cm <sup>2</sup> 36 lbf/in <sup>2</sup>

The above pressures may also be reduced by 0.41 bar; 0.42 kgf/cm<sup>2</sup>; (6 lbf/in<sup>2</sup>) on the front and rear tyres to obtain maximum comfort, provided the speed does not exceed 100 mph (160 km/h).

#### Tyre Replacement and Wheel Interchanging

When replacement of tyres is necessary, it is preferable to fit a complete car set. Should either front or rear tyres only show a necessity for replacement, new tyres must be fitted to replace the worn ones. No attempt must be made to interchange tyres from front to rear or vice-versa as tyre wear produces characteristic patterns depending upon their position and if such position is changed after wear has occurred, the performance of the tyre will be adversely affected. It should be remembered that new tyres require to be balanced.

The radial-ply tyres specified above are designed to meet the high-speed performance of which the car is capable.

Only tyres of identical specification as shown under 'TYRE DATA' must be fitted as replacements and, if to different tread pattern, should not be fitted in mixed form.

UNDER NO CIRCUMSTANCES SHOULD CROSS-PLY TYRES BE FITTED.

### RECOMMENDED SNOW TYRE

The following information relates to the only snow tyre recommended for Jaguar Cars.

Snow tyres MUST ONLY BE fitted in complete sets of four, failure to do so could adversely affect the handling of the car under certain conditions.

**Tyre type** – Pirelli Winter 190 215/65 R15 M&S

**Tyre pressures** – Are the same as the standard tyre equipment.

**Maximum speed** – without snow chains – 190 km/h (118 mph)  
with snow chains – 50 km/h (30 mph)

#### Snow Chains

Rud Kantenspur snow chains may be fitted to the rear wheels only.

**NOTE:** Always ensure that they are correctly fitted and fully tensioned.

Snow chains must only be used with the recommended winter tyres.

## XK ENGINES

- A Emission North America and Japan (1978-80)  
 B Emission Rest of World  
 C Emission Canada and Japan 81 on and Australia 1986  
 D Emission Australia -85 Sweden and Switzerland  
 E Emission Saudia Arabia

	3.4 Pre 81	3.4 After 81
Ignition timing .....	8° B.T.D.C.	8° B.T.D.C.
\$ = Vac off idle normal run temp .....	static	\$
# = Vac off normal running temp .....		
! = at 3000 r.p.m. ....		
& = 700 r.p.m. with vac off .....		
Valve clearances .....	0.012 to 0.014 in	0.012 to 0.014 in
Spark plugs — make/type .....	N12Y	N12Y
— gap .....	0.025 in	0.035 in
Ignition coil — make Lucas/type .....	16C6	16C6
Primary resistance @ 20°C (ohms) .....	1.2 to 1.5	1.2 to 1.5
Output (open circuit) Kv min .....	25	25
Output at plug Kv min (assuming plug gap and lead to spec) .....	10	10
Distributor — make/type .....	45D6	45D6
Rotation of rotor view above .....	Anticlockwise	Anticlockwise
Points gap .....	0.015 in	0.015 in
Pick up coil resistance K Ohms .....	—	—
Firing order .....	1, 5, 3, 6, 2, 4@	1, 5, 3, 6, 2, 4@
@ — cylinders numbered from rear		
Spark plug lead resistances	Min — Max	
1 .....	8.61 to 20.56K	
2 .....	9.00 to 21.48K	
3 .....	7.24 to 17.34K	
4 .....	6.11 to 14.69K	
5 .....	5.47 to 13.20K	
6 .....	5.13 to 12.30K	
Exhaust emission reading Co .....	3% max	3% max
HC .....		
Idle speed .....	750 r.p.m.	750 r.p.m.
Compression pressure .....	135 to 150 lbf/in <sup>2</sup>	135 to 150 lbf/in <sup>2</sup>
Differential between cylinders .....	15% maximum	
Carburettor — type .....	SU HIF7	SU HIF7
— needle .....	BDW	BDW
— jet .....	0.100	0.100
— spring .....	Red	Red
Auto choke — type .....	TZX 1002	TZX 1002

# ENGINE TUNING

## XK ENGINES

- A Emission North America and Japan (1978-80)
- B Emission Rest of World
- C Emission Canada and Japan 81 on and Australia 1986
- D Emission Australia -85 Sweden and Switzerland
- E Emission Saudia Arabia

	4.2 Emiss A 1979-80	4.2 Emiss A 1982	4.2 Emiss A/D Pre 83	4.2 Emiss A 1983	4.2 Emiss A 1984-
Ignition timing	4° B.T.D.C.	14° B.T.D.C.	8° B.T.D.C.	14° B.T.D.C.	17° B.T.D.C.
\$ = Vac off idle normal run temp	at 800 r.p.m.	\$	&	&	&
# = Vac off normal running temp					
! = at 3000 r.p.m.					
& = 700 r.p.m. with vac off					
Valve clearances	0.012 to 0.014 in	0.012 to 0.014 in	0.012 to 0.014 in	0.012 to 0.014 in	0.012 to 0.014 in
Spark plugs — make/type	N12Y	N12Y	N12Y	N12Y	N12Y
— gap	0.035 in	0.035 in	0.035 in	0.035 in	0.035 in
Ignition coil — make Lucas/type	16C6	16C6	16C6	32C5	32C5
Primary resistance @ 20°C (ohms)	1.2 to 1.5	1.2 to 1.5	1.2 to 1.5	0.75 to 0.85	0.75 to 0.85
Output (open circuit) Kv min	25	25	25	25	25
Output at plug Kv min (assuming plug gap and lead to spec)	10	10	10	10	10
Ignition coil — Ducellier/type	—	—	—	—	520076A
Primary resistance @ 20°C (ohms)	—	—	—	—	0.8 to 1.0
Ballast resistance @ 20°C (ohms)	—	—	—	—	0.8 to 1.0
Output (open circuit) Kv min					25
Output at plug Kv min (assuming plug gap and lead to spec)					10
Distributor — make/type	45DM6	45DM6	45DM6	45DM6	45DM6
Rotation of rotor view above	Anticlockwise	Anticlockwise	Anticlockwise	Anticlockwise	Anticlockwise
Pick up mod/rot gap	0.008 to 0.014 in	0.008 to 0.014 in	0.008 to 0.014 in	0.008 to 0.014 in	0.008 to 0.014 in
Pick up coil resistance K Ohms	2.2 to 4.8	2.2 to 4.8	2.2 to 4.8	2.2 to 4.8	2.2 to 4.8
Firing order	1, 5, 3, 6, 2, 4@	1, 5, 3, 6, 2, 4@	1, 5, 3, 6, 2, 4@	1, 5, 3, 6, 2, 4@	1, 5, 3, 6, 2, 4@
@ — cylinders numbered from rear					
Spark plug lead resistances	Min — Max				
1	8.61 to 20.56K				
2	9.00 to 21.48K				
3	7.24 to 17.34K				
4	6.11 to 14.69K				
5	5.47 to 13.20K				
6	5.13 to 12.30K				
Exhaust emission reading Co	0.5 to 1.5%	0.5 to 1.5%	0.5 to 1.5%	0.5 to 1.5%	0.5 to 1.5%
HC					
Idle speed	750 r.p.m.	750 ± 50 r.p.m.	750 r.p.m.	800 r.p.m.	800 r.p.m.
Compression pressure	120 to 135 lbf/in <sup>2</sup>	120 to 135 lbf/in <sup>2</sup>	120 to 135 lbf/in <sup>2</sup>	120 to 135 lbf/in <sup>2</sup>	120 to 135 lbf/in <sup>2</sup>
Differential between cylinders			15% maximum		
Fuel pressure			35.5 to 38.8 lbf/in <sup>2</sup>		

## XK ENGINES

- A Emission North America and Japan (1978-80)  
 B Emission Rest of World  
 C Emission Canada and Japan 81 on and Australia 1986  
 D Emission Australia -85 Sweden and Switzerland  
 E Emission Saudia Arabia

	4.2 Emiss B	4.2 Emiss C 1985-6	4.2 Swiss 1985-6	4.2 Australia 1985
Ignition timing	6° B.T.D.C.	14° B.T.D.C.	4° ± 2	4° B.T.D.C.
\$ = Vac off idle normal run temp	\$	!	B.T.D.C.\$	at 800 r.p.m.
# = Vac off normal running temp				
! = at 3000 r.p.m.				
& = 700 r.p.m. with vac off				
Valve clearances	0.012 to 0.014 in	0.012 to 0.014 in	0.012 to 0.014 in	0.012 to 0.014 in
Spark plugs — make/type	N10Y	N12Y	N12Y	N12Y
— gap	0.035 in	0.035 in	0.035 in	0.035 in
Ignition coil — make Lucas/type	32C5	32C5	32C5	32C5
Primary resistance @ 20°C (ohms)	0.75 to 0.85	0.75 to 0.85	0.75 to 0.85	0.75 to 0.85
Output (open circuit) Kv min	25	25	25	25
Output at plug Kv min (assuming plug gap and lead to spec)	10	10	10	10
Ignition coil — Ducellier/type	520076A	520076A	520076A	520076A
Primary resistance @ 20°C (ohms)	0.8 to 1.0	0.8 to 1.0	0.8 to 1.0	0.8 to 1.0
Ballast resistance @ 20°C (ohms)	0.8 to 1.0	0.8 to 1.0	0.8 to 1.0	0.8 to 1.0
Output (open circuit) Kv min	25	25	25	25
Output at plug Kv min (assuming plug gap and lead to spec)	10	10	10	10
Distributor — make/type	45DM6	45DM6	45DM6	45DM6
Rotation of rotor view above	Anticlockwise	Anticlockwise	Anticlockwise	Anticlockwise
Pick up mod/rot gap	0.008 to 0.014 in	0.008 to 0.014 in	0.008 to 0.014 in	0.008 to 0.014 in
Pick up coil resistance K Ohms	2.2 to 4.8	2.2 to 4.8	2.2 to 4.8	2.2 to 4.8
Firing order	1, 5, 3, 6, 2, 4@	1, 5, 3, 6, 2, 4@	1, 5, 3, 6, 2, 4@	1, 5, 3, 6, 2, 4@
@ — cylinders numbered from rear				
Spark plug lead resistances	Min — Max			
1	8.61 to 20.56K			
2	9.00 to 21.48K			
3	7.24 to 17.34K			
4	6.11 to 14.69K			
5	5.47 to 13.20K			
6	5.13 to 12.30K			
Exhaust emission reading Co	1.25 to 1.75	1.25 to 1.75	0.75 ± 25%	0.5 to 1.0%
HC			300 p.p.m. max	
Idle speed	750 r.p.m.	750 ± 50 r.p.m.	800 ± 100 r.p.m.	800 r.p.m.
Compression pressure	135 to 150 lbf/in <sup>2</sup>	135 to 150 lbf/in <sup>2</sup>	135 to 150 lbf/in <sup>2</sup>	135 to 150 lbf/in <sup>2</sup>
Differential between cylinders			15% maximum	
Fuel pressure			35.5 to 38.8 lbf/in <sup>2</sup>	

# ENGINE TUNING

## V12 ENGINES

- A Emission North America and Japan (1978-80)
- B Emission Rest of World
- C Emission Canada and Japan 81 on and Australia 1986
- D Emission Australia -85 Sweden and Switzerland
- E Emission Saudia Arabia

	D Jetronic	
	5.3	5.3
	A Emiss	D Emiss
Ignition timing .....	10° B.T.D.C.	4° B.T.D.C.
\$ = Vac off idle normal run temp at 3000 r.p.m. ....	Static	Static
Valve clearances .....	0.012 to 0.014 in	0.012 to 0.014 in
Spark plugs — make/type .....	N10Y	N10Y
— gap .....	0.035 in	0.035 in
Ignition coil — make/type .....	22C12	22C12
Primary resistance @ 20°C (ohms) .....	0.9 to 1.1	0.9 to 1.1
Output (open circuit) Kv min .....	25	25
Output at plug Kv min (assuming plug gap and lead to spec) .....	10	10
Distributor — make/type .....	36DE12	36DE12
Rotation of rotor view above .....	Anticlockwise	Anticlockwise
Pick up mod/rot gap .....	0.020 to 0.025 in	0.020 to 0.025 in
Pick up coil resistance K Ohms .....	—	—
Firing order .....	1A-6B-5A-2B-3A-4B-6A-1B-2A-5B-4A-3B*	
* — cylinders numbered from front		
Spark plug lead resistances .....	Min — Max	Min — Max
	1A 3.05 to 7.35K	1B 4.00 to 9.66K
	2A 2.09 to 5.04K	2B 2.78 to 6.72K
	3A 2.27 to 5.46K	3B 1.31 to 3.15K
	4A 3.48 to 8.40K	4B 2.00 to 4.83K
	5A 3.13 to 7.56K	5B 3.31 to 7.98K
	6A 3.22 to 7.77K	6B 3.92 to 9.45K
Exhaust emission reading Co .....	1 to 2%	1 to 2%
Idle speed .....	750 r.p.m.	750 r.p.m.
HC .....		
Compression pressure .....	135 lbf/in <sup>2</sup>	135 lbf/in <sup>2</sup>
Differential between cylinders .....	15% maximum	
Fuel pressure .....	28.5 to 30.8 lbf/in <sup>2</sup>	

V12 ENGINES

- A Emission North America and Japan (1978-80)
- B Emission Rest of World
- C Emission Canada and Japan 81 on and Australia 1986
- D Emission Australia -85 Sweden and Switzerland
- E Emission Saudia Arabia

	P System PI Digital			
	5.3 A Emiss Pre HE	5.3 B Emiss Pre HE 9:1	5.3 B Emiss Pre HE 10:1 to 301612	5.3 B Emiss Pre HE-
Ignition timing	25 to 27°	5°B.T.D.C.	10°B.T.D.C.	24°B.T.D.C.
\$ = Vac off idle normal run temp	B.T.D.C. #	Vac on	#	#
# = Vac off normal running temp at 3000 r.p.m.				
Valve clearances	0.012 to 0.014 in	0.012 to 0.014 in	0.012 to 0.014 in	0.012 to 0.014 in
Spark plugs — make/type	N10Y	N10Y	N10Y	N10Y
— gap	0.035 in	0.035 in	0.035 in	0.035 in
Ignition coil — make/type	22C12	23C12	23C12	23C12
Primary resistance @ 20°C (ohms)	0.9 to 1.1	0.7 to 0.85	0.7 to 0.85	0.7 to 0.85
Output (open circuit) Kv min	25	25	25	25
Output at plug Kv min (assuming plug gap and lead to spec)	10	10	10	10
Distributor — make/type	36DE12	36DE12	36DE12	36DE12
Rotation of rotor view above	Anticlockwise	Anticlockwise	Anticlockwise	Anticlockwise
Points/pick up mod/rot gap	0.020 to 0.025 in	0.020 to 0.025 in	0.020 to 0.025 in	0.020 to 0.025 in
Pick up coil resistance K Ohms	2.2 to 4.8	2.2 to 4.8	2.2 to 4.8	2.2 to 4.8
Firing order	1A-6B-5A-2B-3A-4B-6A-1B-2A-5B-4A-3B*			
* — cylinders numbered from front				
Spark plug lead resistances	Min — Max	Min — Max		
	1A 3.05 to 7.35K	1B 4.00 to 9.66K		
	2A 2.09 to 5.04K	2B 2.78 to 6.72K		
	3A 2.27 to 5.46K	3B 1.31 to 3.15K		
	4A 3.48 to 8.40K	4B 2.00 to 4.83K		
	5A 3.13 to 7.56K	5B 3.31 to 7.98K		
	6A 3.22 to 7.77K	6B 3.92 to 9.45K		
Exhaust emission reading Co	1 to 2%	1 to 2%	1 to 2%	1 to 2%
Idle speed	750 r.p.m.	750 r.p.m.	750 r.p.m.	750 r.p.m.
HC				
Compression pressure	135 lbf/in <sup>2</sup>	135 lbf/in <sup>2</sup>	150 lbf/in <sup>2</sup>	165 lbf/in <sup>2</sup>
Differential between cylinders			15% maximum	
Fuel pressure			35.5 to 38.8 lbf/in <sup>2</sup>	

# ENGINE TUNING

## V12 ENGINES

- A Emission North America and Japan (1978-80)
- B Emission Rest of World
- C Emission Canada and Japan 81 on and Australia 1986
- D Emission Australia -85 Sweden and Switzerland
- E Emission Saudia Arabia

### P System PI Digital

	5.3 A & B Em HE	5.3 A & B Em HE After 7P50275	5.3 Australia 1985	5.3 Switzerland 1985
Ignition timing	18° B.T.D.C.	18° B.T.D.C.	18° B.T.D.C.	18° +0-2
\$ = Vac off idle normal run temp	#	#	#	B.T.D.C.
# = Vac off normal running temp at 3000 r.p.m.				
Valve clearances	0.010 to 0.012 in	0.010 to 0.012 in	0.010 to 0.012 in	0.010 to 0.012 in
Spark plugs — make/type	BN5	RS5C	RS5C	RS5C
— gap	0.025 in	0.025 in	0.025 in	0.025 in
Ignition coil — make/type	35C6x2	35C6x2	35C6x2	35C6x2
Primary resistance @ 20°C (ohms)	0.6 to 0.8	0.6 to 0.8	0.6 to 0.8	0.6 to 0.8
Output (open circuit) Kv min	25	25	25	25
Output at plug Kv min (assuming plug gap and lead to spec)	10	10	10	10
Distributor — make/type	36DM12	36DM12	36DM12	36DM12
Rotation of rotor view above	Anticlockwise	Anticlockwise	Anticlockwise	Anticlockwise
Points/pick up mod/rot gap	0.006 to 0.014 in	0.006 to 0.014 in	0.006 to 0.014 in	0.006 to 0.014 in
Pick up coil resistance K Ohms	2.2 to 4.8	2.2 to 4.8	2.2 to 4.8	2.2 to 4.8
Firing order	1A-6B-5A-2B-3A-4B-6A-1B-2A-5B-4A-3B*			
@ — cylinders numbered from rear				
* — cylinders numbered from front				
Spark plug lead resistances	Min — Max	Min — Max		
	1A 3.05 to 7.35K	1B 4.00 to 9.66K		
	2A 2.09 to 5.04K	2B 2.78 to 6.72K		
	3A 2.27 to 5.46K	3B 1.31 to 3.15K		
	4A 3.48 to 8.40K	4B 2.00 to 4.83K		
	5A 3.13 to 7.56K	5B 3.31 to 7.98K		
	6A 3.22 to 7.77K	6B 3.92 to 9.45K		
Exhaust emission reading Co	1 to 2%	1 to 2%	0.5 to 1%	0.75 ± 0.25%
Idle speed	750 r.p.m.	750 r.p.m.	800 r.p.m.	800 ± 50 r.p.m.
HC				500 p.p.m. max.
Compression pressure	200 to 240 lbf/in <sup>2</sup>	200 to 240 lbf/in <sup>2</sup>	200 to 240 lbf/in <sup>2</sup>	200 to 240 lbf/in <sup>2</sup>
Differential between cylinders				15% maximum
Fuel pressure				35.5 to 38.8 lbf/in <sup>2</sup>
Ignition timing	16° ± 1° BTDC	16° ± 1° BTDC	16° ± 1° BTDC	
Spark plugs — make/type	EAC 9186 Champion RS9YC	EAC 8554 NGK BR7 EFS	EAC 8554 NGK BR7 EFS	



## GENERAL FITTING INSTRUCTIONS

### Precautions Against Damage

Always fit covers to protect the wings before commencing work in the engine department. Cover the seats and carpets, wear clean overalls and wash your hands or wear gloves before working inside the car. Avoid spilling hydraulic fluid or battery acid on paintwork. Wash off with water immediately if this occurs. Use polythene sheets in the boot to protect carpets. Always use a recommended service oil, or a satisfactory equivalent, where specified. Protect temporarily exposed screw threads by replacing nuts or fitting plastic caps.

### Safety Precautions

Whenever possible use a ramp or pit when working beneath a car, in preference to jacking. Chock the wheels as well as applying the handbrake. Never rely on a jack alone to support a car. Use axle stands or blocks carefully placed at the jacking points to provide a rigid location. Ensure that a suitable form of fire extinguisher is conveniently located. Check that any lifting equipment used has adequate capacity and is fully serviceable. Inspect power leads of any mains electrical equipment for damage, and check that it is properly earthed. Disconnect the earth (grounded) terminal of a car battery. Do not disconnect any pipes in the air conditioning refrigeration system, if fitted, unless trained and instructed to do so. A refrigerant is used which can cause blindness if allowed to contact the eyes. Ensure that adequate ventilation is provided when volatile de-greasing agents are being used.

**CAUTION:** Fume extraction equipment must be in operation when trichlorethylene, carbon tetrachloride, methylene chloride, chloroform, or perchlorethylene are used for cleaning purposes.

Do not apply heat in an attempt to free stiff nuts or fittings; as well as causing damage to protective coatings, there is a risk of damage to electronic equipment and brake lines from stray heat.

Do not leave tools, equipment, spilt oil, etc., around or on work area.

### Safe use of Petrol

When draining petrol tanks, choose a well ventilated area preferably out of doors. Never drain petrol over a pit; keep all sources of ignition well away; use a proper fuel retriever or syphon whenever possible; if draining into a container use a funnel.

Store petrol in secure containers, properly labelled in a store agreed by your local petroleum licensing authority (Trading Standard Dept of Fire Brigade).

Carry petrol in a clearly labelled metal or approved plastic can securely closed.

Use petrol as a fuel only and not for cleaning hands, clothing or components. Do not add petrol to diesel fuel or put petrol on bonfires.

Avoid splashes and spillages; always use a funnel or filling spout for filling in a well ventilated area. If clothing is splashed, change as soon as possible. Keep the clothing away from heat and sources of ignition and tell whoever washes it about the petrol splashes.

Clean up or contain any spillage straight away and open doors and windows.

Keep ignition sources, e.g. handlamps, heaters and welding sets away from petrol.

Dispose of any petrol soaked rags safely.

DO NOT smoke when handling petrol.

NEVER play with petrol, it is highly dangerous and illegal.

### Used Engine Oils

**Prolonged** and **repeated** contact with mineral oil will result in the removal of natural fats from the skin, leading to dryness, irritation and dermatitis. In addition, **used** engine oil contains potentially harmful contaminants which may cause skin cancer. Adequate means of skin protection and washing facilities should be provided.

### Health Protection Precautions

1. Avoid prolonged and repeated contact with oils, particularly used engine oils.
2. Wear protective clothing, including impervious gloves where practicable.
3. Do not put oily rags in pockets.
4. Avoid contaminating clothes, particularly underpants, with oil.
5. Overalls must be cleaned regularly. Discard unwashable clothing and oil impregnated footwear.
6. First Aid treatment should be obtained immediately for open cuts or wounds.
7. Use barrier creams, applying before each work period, to help the removal of oil from the skin.
8. Wash with soap and water to ensure all oil is removed (skin cleaners and nail brushes will help). Preparations containing lanolin replace the natural skin oils which have been removed.
9. Do not use petrol, kerosine, diesel fuel, gas oil, thinners or solvents for washing skin.
10. If skin disorders develop, obtain medical advice.
11. Where practicable, degrease components prior to handling.
12. Where there is a risk of eye contact, eye protection should be worn, for example, chemical goggles or face shields; in addition an eye wash facility should be provided.

### Environmental Protection Precautions

It is illegal to pour used oil on to the ground, down sewers or drains, or into water courses.

The burning of used engine oil in small space heaters or boilers is not recommended unless emission control equipment is fitted; in cases of doubt, check with the Local Authority.

Dispose of used oil through authorised waste disposal contractors, or licensed waste disposal sites or to the waste oil reclamation trade. If in doubt, contact the Local Authority for advice on disposal facilities.

### Preparation

Before removing a component, clean it and its surrounding area as thoroughly as possible.

Blank off any openings exposed by component removal, using greaseproof paper and masking tape.

Immediately seal fuel, oil or hydraulic lines when separated, using plastic caps or plugs, to prevent loss of fluid and entry of dirt.

Close the open ends of oilways, exposed by component removal, with tapered hardwood plugs or readily visible plastic plugs.

Immediately a component is removed, place it in a suitable container; use a separate container for each component and its associated parts.

Before dismantling a component clean it thoroughly with a recommended cleaning agent; check that the agent is suitable for all materials of component.

Clean the bench and provide marking materials, labels, containers and locking wire before dismantling a component.

### Dismantling

Observe scrupulous cleanliness when dismantling components, particularly when brake, fuel or hydraulic system parts are being worked on. A particle of dirt or a cloth fragment could cause a dangerous malfunction if trapped in these systems.

Blow out all trapped holes, crevices, oilways and fluid passages with an air line. Ensure that and 'O' rings used for sealing are correctly replaced or renewed if disturbed.

Mark mating parts to ensure that they are replaced as dismantled. Whenever possible use marking ink, which avoids possibilities of distortion or initiation of cracks, liable if centre-punch or scriber are used.

Wire together mating parts where necessary to prevent accidental interchange (e.g. roller bearing components).

Wire labels onto all parts which are to be renewed, and to parts requiring further inspection before being passed for reassembly; place these parts in separate containers from those containing parts for rebuild.

Do not discard a part due for renewal until after comparing it with a new part, to ensure that its correct replacement has been obtained.

### Inspection – General

Never inspect a component for wear or dimensional check unless it is absolutely clean; a slight smear of grease can conceal an incipient failure. When a component is to be checked dimensionally against figures quoted for it, use correct equipment (surface plates, micrometers,

## GENERAL FITTING INSTRUCTIONS

dial gauges, etc.) in serviceable condition. Makeshift checking equipment can be dangerous. Reject a component if its dimensions are outside the limits quoted, or if damage is apparent. A part may, however, be refitted if its critical dimension is exactly limit size, and is otherwise satisfactory.

Use Plastigauge 12 Type PG-1 for checking bearing surface clearances.

Directions for its use, and a scale giving bearing clearances in 0,0025 mm (0.0001 in) steps are provided with it.

### Ball and Roller Bearings

NEVER REPLACE A BALL OR ROLLER BEARING WITHOUT FIRST ENSURING THAT IT IS IN AS-NEW CONDITION.

Remove all traces of lubricant from a bearing under inspection by washing it in petrol or a suitable de-greaser; maintain absolute cleanliness throughout the operations.

Inspect visually for markings of any form on rolling elements, raceways, outer surface of outer rings or inner surface of inner rings. Reject any bearings found to be marked, since any markings in these areas indicates onset of wear.

Holding the inner race between finger and thumb of one hand, spin the outer race and check that it revolves absolutely smoothly. Repeat, holding the outer race and spinning the inner race.

Rotate the outer ring with a reciprocating motion, while holding the inner ring; feel for any check or obstruction to rotation, and reject the bearing if action is not perfectly smooth.

Lubricate the bearing generously with lubricant appropriate to installation. Inspect shaft and bearing housing for discolouration or other marking suggesting that movement has taken place between bearing and seatings.

If markings are found use Loctite in installation of replacement bearing.

Ensure that the shaft and housing are clean and free from burrs before fitting the bearing.

If one bearing of a pair shows an imperfection it is generally advisable to renew both bearings; an exception could be made only if the faulty bearing had covered a low mileage, and it could be established that damage was confined to it. When fitting bearing to shaft, apply force only to inner ring of bearing, and only to outer ring when fitting into housing (Fig. 1).

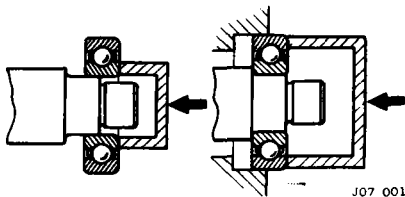

Fig. 1

In the case of grease-lubricated bearings (e.g. hub bearings) fill the space between the bearings and outer seal with a recommended grade of grease before fitting the seal.

Always mark components of separable bearings (e.g. taper-roller bearings) in dismantling, to ensure correct reassembly. Never fit new rollers in a used cup.

### Oil Seals

Always fit new oil seals when rebuilding an assembly. It is not physically possible to replace a seal exactly as it had bedded down.

Carefully examine the seal before fitting to ensure that it is clean and undamaged.

Smear sealing lips with clean grease; pack dust excluder seals with grease, and heavily grease duplex seals in cavity between sealing lips.

Ensure that seal spring, if provided, is correctly fitted.

Place lip of seal towards fluid to be sealed and slide into position on shaft, using fitting sleeve (Fig. 2) when possible to protect sealing lip from damage by sharp corners, threads or splines. If fitting sleeve is not available, use plastic tube or adhesive tape to prevent damage to sealing lip.

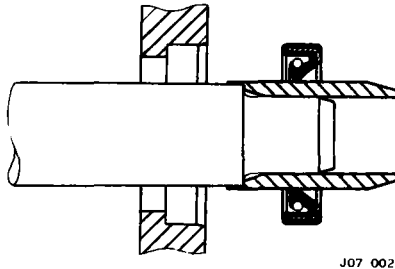

Fig. 2

Grease the outside diameter of the seal, place it square to the housing recess and press it into position, using great care and if possible a 'bell piece' (Fig. 3) to ensure that seal is not tilted. (In some cases it may be preferable to fit the seal to the housing before fitting to the shaft). Never let weight of an unsupported shaft rest in a seal.

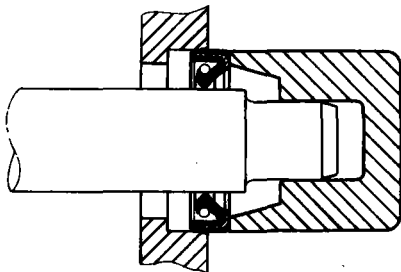

Fig. 3

If correct service tool is not available, use a suitable drift approximately 0,4 mm (0.015 in) smaller than the outside diameter of the seal. Use a hammer VERY GENTLY on the drift if a press is not suitable.

Press or drift a seal into the depth of housing if the housing is shouldered, or flush with the face of the housing where no shoulder is provided.

**NOTE:** Most cases of failure or leakage of oil seals are due to careless fitting, and resulting damage to both seals and sealing surfaces. Care in fitting is essential if good results are to be obtained.

### Joints and Joint Faces

Always use the correct gaskets where they are specified.

Use jointing compound only when recommended. Otherwise fit joints dry.

When jointing compound is used, apply in a thin uniform film to metal surfaces; take great care to prevent it from entering oilways, pipes or blind tapped holes.

Remove all traces of old jointing materials prior to reassembly. Do not use a tool which could damage joint faces.

Inspect joint faces for scratches or burrs and remove with a fine file or oil-stone; do not allow swarf or dirt to enter tapped holes or enclosed parts. Blow out any pipes, channels or crevices with compressed air, renewing any 'O' rings or seals displaced by air blast.

### Flexible Hydraulic Pipes, Hoses

Before removing any brake or power steering hose, clean end fittings and area surrounding them as thoroughly as possible.

Obtain appropriate blanking caps before detaching hose end fittings, so that ports can be immediately covered to exclude dirt.

Clean hose externally and blow through with airline. Examine carefully for cracks, separation of plies, security of end fittings and external damage. Reject any hose found faulty.

When refitting hose, ensure that no unnecessary bends are introduced, and that hose is not twisted before or during tightening of union nuts. Containers for hydraulic fluid must be kept absolutely clean.

Do not store hydraulic fluid in an unsealed container. It will absorb water, and fluid in this condition would be dangerous to use due to a lowering of its boiling point.

Do not allow hydraulic fluid to be contaminated with mineral oil, or use a container which has previously contained mineral oil.

Do not re-use fluid bled from system. Always use clean brake fluid, or a recommended alternative, to clean hydraulic components.

Fit a blanking cap to a hydraulic union and a plug to its socket after removal to prevent ingress of dirt.

Absolute cleanliness must be observed with hydraulic components at all times.

After any work on hydraulic systems, inspect carefully for leaks underneath the car while a second operator applies maximum pressure to the brakes (engine running) and operates the steering.

### Metric Bolt Identification

An ISO metric bolt or screw, made of steel and larger than 6 mm in diameter can be identified by either of the symbols ISO M or M embossed or indented on top of head (Fig. 4).

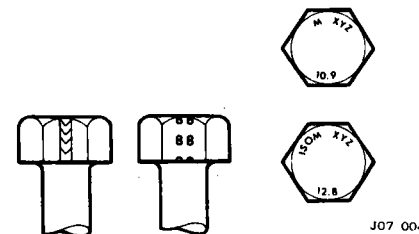

Fig. 4

In addition to marks to identify the manufacture, the head is also marked with symbols to indicate the strength grade i.e. 8.8, 10.9, 12.9, or 14.9, where the first figure gives the minimum tensile strength of the bolt material in tens of kgf/mm<sup>2</sup>. Zinc plated ISO metric bolts and nuts are chromate passivated, a greenish-khaki to gold-bronze colour.

**Metric Nut Identification**

A nut with an ISO metric thread is marked on one face (1, Fig. 5) or on one of the flats (2, Fig. 5) of the hexagon with the strength grade symbol 8, 12 or 14. Some nuts with a strength 4, 5 or 6 are also marked and some have the metric symbol M on the flat opposite the strength grade marking.

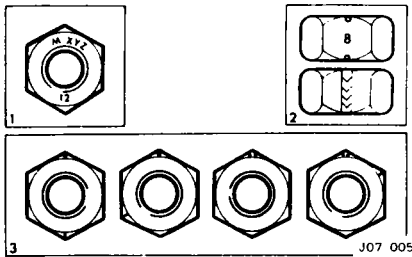

Fig. 5

A clock face system (3, Fig. 5) is used as an alternative method of indicating the strength grade. The external chamfers or a face of the nut is marked in a position relative to the appropriate hour mark on a clock face to indicate the strength grade.

A dot is used to locate the 12 o'clock position and a dash to indicate the strength grade. If the grade is above 12, two dots identify the 12 o'clock position.

**Hydraulic Fittings – Metrication**

**WARNING: Metric and Unified threaded hydraulic parts. Although pipe connections to brake system units incorporate threads of metric form, those for power assisted steering are of U.N.F. type. It is vitally important that these two thread forms are not confused, and careful study should be made of the following notes.**

Metric threads and metric sizes are being introduced into motor vehicle manufacture and some duplication of parts must be expected. Although standardization must in the long run be good, it would be wrong not to give warning of the dangers that exist while U.N.F. and metric threaded hydraulic parts continue together in service.

Fitting U.N.F. pipe nuts into metric ports and vice-versa should not happen, but experience of the change from B.S.F. to U.N.F. indicated that there is no certainty in relying upon the difference in thread size when safety is involved. To provide permanent identification of metric parts is not easy but recognition has been assisted by the following means:

All metric pipe nuts, hose ends, unions and bleed screws are coloured black.

The hexagon area of pipe nuts is indented with the letter 'M'.

Metric and U.N.F. pipe nuts are slightly different in shape.

**NOTE:** In Figs 6 to 9, A indicates the metric type and 'B' the U.N.F. type.

The metric female nut is **always** used with a trumpet flared pipe and the metric male nut is **always** used with a convex flared pipe (Fig. 6).

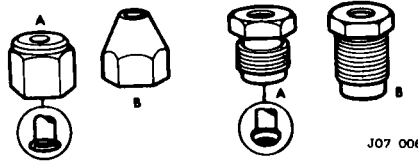

Fig. 6

All metric ports in cylinders and calipers have no counterbores, but unfortunately a few cylinders with U.N.F. threads also have no counterbore. The situation is, all parts with counterbores are U.N.F., but ports not counterbored are most likely to be metric (Fig. 7)



Fig. 7

The colour of the protective plugs in hydraulic ports indicates the size and the type of the threads, but the function of the plugs is protective and not designed as positive identification. In production it is difficult to use the wrong plug but human error must be taken into account.

The plug colours and thread sizes are:

	<b>U.N.F.</b>
RED	3/8" x 24 U.N.F.
GREEN	7/8" x 20 U.N.F.
YELLOW	1/2" x 20 U.N.F.
PINK	3/4" x 18 U.N.F.

	<b>METRIC</b>
BLACK	10 x 1 mm
GREY	12 x 1 mm
BROWN	14 x 1,5 mm

Hose ends differ slightly between metric and U.N.F. (Fig. 8)

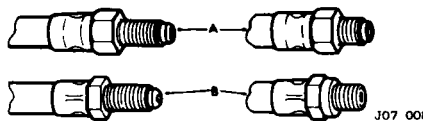

Fig. 8

Gaskets are not used with metric hoses. The U.N.F. hose is sealed on the cylinder or caliper face by a copper gasket but the metric hose seals against the bottom of the port and there is a gap between faces of the hose end and cylinder (Fig. 9).



Fig. 9

Pipe sizes for U.N.F. are 3/8 in, 1/2 in, and 5/8 in outside diameter.

Metric pipe sizes are 4,75 mm, 6 mm and 8 mm. 4.75 mm pipe is exactly the same as 3/8 in pipe.

6 mm pipe is 0.014 in smaller than 1/2 in pipe. 8 mm pipe is 0.002 in larger than 5/8 in pipe.

Convex pipe flares are shaped differently for metric sizes and when making pipes for metric equipment, metric pipe flaring tools must be used. The greatest danger lies with the confusion of 10 mm and 3/4 in U.N.F. pipe nuts used for 5/8 in (or 4,75 mm) pipe. The 3/4 in U.N.F. pipe nut or hose can be screwed into a 10 mm port but is very slack and easily stripped. The thread engagement is very weak and cannot provide an adequate seal. The opposite condition, a 10 mm nut in a 3/4 in port, is difficult and unlikely to cause trouble. The 10 mm nut will screw in 1 1/2 or two turns and seize. It has a crossed thread 'feel' and it is impossible to force the nut far enough to seal the pipe. With female pipe nuts the position is of course reversed.

The other combinations are so different that there is no danger of confusion.

**Keys and Keyways**

Remove burrs from edges of keyways with a fine file and clean thoroughly before attempting to refit key.

Clean and inspect key closely; keys are suitable for refitting only if indistinguishable from new, as any indentation may indicate the onset of wear.

**Split Pins**

Fit new split pins throughout when replacing any unit.

Always fit split pins where split pins were originally used. Do not substitute spring washers; there is always a good reason for the use of a split pin.

All split pins should be fitted as shown in Fig. 10 unless otherwise stated.

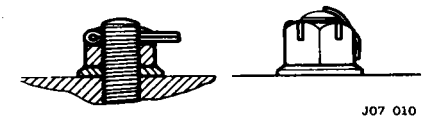

Fig. 10

**Tab Washers**

Fit new tab washers in all places where they are used. Never replace with a used tab washer. Ensure that the new tab washer is of the same design as that replaced.

**Nuts**

When tightening up a slotted or castellated nut **never slacken it back** to insert split pin or locking wire except in those recommended cases where this forms part of an adjustment. If difficulty is experienced, alternative washers or nuts should be selected, or washer thickness reduced.

Where self-locking nuts have been removed it is advisable to replace them with new ones of the same type.

**NOTE:** Where bearing pre-load is involved nuts should be tightened in accordance with special instructions.

# GENERAL FITTING INSTRUCTIONS

---

## Locking Wire

Fit new locking wire of the correct type for all assemblies incorporating it.

Arrange wire so that its tension tends to tighten the bolt heads, or nuts, to which it is fitted.

## Screw Threads

Both U.N.F. and Metric threads to ISO standards are used. See below for thread identification.

Damaged threads must always be discarded.

Cleaning up threads with a die or tap impairs the strength and closeness of fit of the threads and is not recommended.

Always ensure that replacement bolts are at least equal in strength to those replaced.

Do not allow oil, grease or jointing compound to enter blind threaded holes. The hydraulic action on screwing in the bolt or stud could split the housing.

Always tighten a nut or bolt to the recommended torque figure. Damaged or corroded threads can affect the torque reading.

To check or re-tighten a bolt or screw to a specified torque figure, first slacken a quarter of a turn, then re-tighten to the correct figure.

Always oil thread lightly before tightening to ensure a free running thread, except in the case of self-locking nuts.

## Unified Thread Identification

### Bolts

A circular recess is stamped in the upper surface of the bolt head (1, Fig. 11).

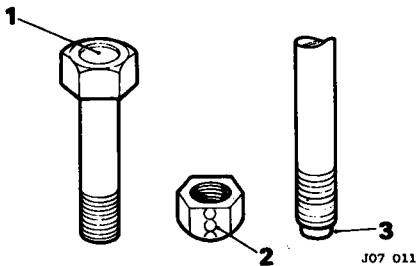

Fig. 11

### Nuts

A continuous line of circles is indented on one of the flats of the hexagon, parallel to the axis of the nut (2, Fig. 11).

### Studs, Brake Rods, etc.

The component is reduced to the core diameter for a short length at its extremity (3, Fig. 11).

## JACKING, LIFTING AND TOWING

### JACKING POINT

Four jacking points are provided beneath the body side-members (1, Fig. 1), one in front of each rear wheel and one behind each front wheel. They consist of downward-facing spigots (2, Fig. 1) designed to engage the lifting head of the tool kit jack (3, Fig. 1).

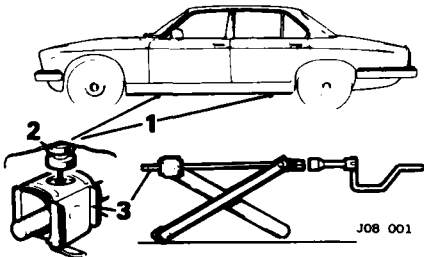

Fig. 1

Ensure that the jack head is fully engaged with spigot before lifting the car, and that wheels on side opposite to that being lifted are chocked, as well as checking handbrake application.

### STANDS

When carrying out any work which requires a wheel to be raised (apart from a simple wheel-change) always replace the tool kit jack by a stand engaging the jacking spigot, to provide secure support.

### WORKSHOP JACK

#### Front—one wheel

Place the jack head under the lower spring support pan, interposing a suitable wooden block before raising the wheel. Place a stand in position at the adjacent spigot and remove the jack before working on the car.

#### Rear—one wheel (Fig. 2)

Place the jack head under the outer fork of the wishbone at the wheel to be raised; interpose a suitable wooden block between the jack head and the wishbone, ensuring that the aluminium alloy hub carrier and its grease nipple will not be contacted by the block as the wheel is raised. Place a stand in position at the adjacent spigot and remove the jack before working on the car.

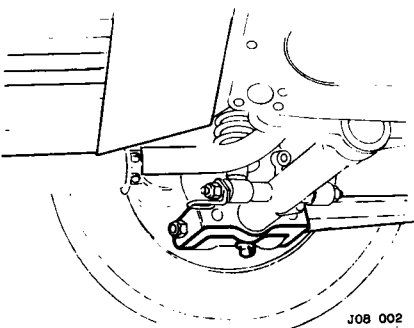

Fig. 2

#### Front—both wheels (Fig. 3)

Place the jack, with a shallow wooden block on its head, centrally beneath the front cross-member, between the lower wishbones. Raise the car, then lower it on to two stands engaging the front jacking spigots; remove the jack before working on the car.

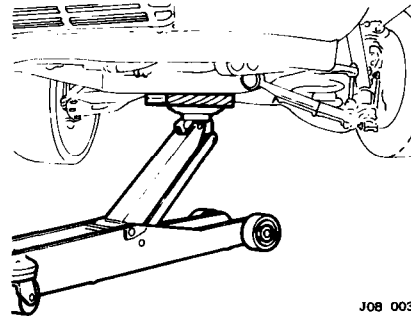

Fig. 3

#### Rear—both wheels (Fig. 4)

Place the jack head centrally under the plate below the final drive unit and interpose a wooden block between the jack head and plate, the block being shaped to prevent load being applied to the plate flanges. Raise the rear end of the car, then lower on to two stands engaging rear jacking spigots; remove the jack before working on the car.

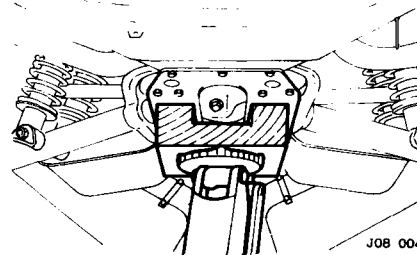

Fig. 4

### LIFTING

Locate lifting pads at the four jacking spigots.

### TOWING

Two towing eyes are provided on all cars, located adjacent to the front cross-member forward attachments, for use in towing from the front. Tie-down lugs at rear damper lower attachments are NOT suitable for rear towing. When towing an automatic transmission car, it is essential to carry out the following operations:

#### A. With automatic transmission functioning correctly:

1. Add 1.7 litres (3.0 pints) of correct automatic transmission fluid to the transmission, via the underbonnet filler tube.
2. Place the selector lever at 'N'.
3. Check that the ignition key is in place, and turn it to position '1'.
4. Tow the car at a speed not exceeding 48 km/h (30 m.p.h.) for not more than 48 km (30 miles).

5. After completing the tow, remove sufficient fluid from the transmission to restore correct reading on the dipstick.

**CAUTION:** It must be remembered that steering is no longer power-assisted when the engine is not running, and that the brake servo will become ineffective after a few applications of the brakes. Be prepared, therefore, for relatively heavy steering and the need for increased pressure on the brake pedal. This applies to manual transmission cars as well as to those with automatic transmission.

**B. With automatic transmission defective,** either tow the car with the rear wheels clear of the ground, or disconnect the propeller shaft at the final drive input flange and firmly secure the rear end of the shaft to one side of the flange. Restrictions on towing distance do not apply when the output shaft of the gearbox is not being turned, but it is still essential that the ignition key is turned to position '1' and the cautionary note above still applies.

**Recovery of cars fitted with manual gearbox:** Due to the possibility of internal gearbox damage, resulting from inadequate lubrication, it is essential, if the car is to be towed, that either the rear wheels are clear of the ground, or the propeller shaft is disconnected from the final drive input flange. If the propeller shaft is disconnected it must be firmly secured away from the final drive flange. Ensure that the ignition key is in position '1'.

### TRANSPORTING

#### Automatic transmission cars only

**CAUTION:** When the vehicle is being transported the selector lever must be in 'N' or 'D', never in 'P'. To obviate the possibility of damage to the pawl mechanism, the handbrake should be applied.

RECOMMENDED LUBRICANTS, FLUIDS, CAPACITIES AND DIMENSIONS

Engine Oil—Recommended S.A.E. Viscosity Range / Ambient Temperature Scale

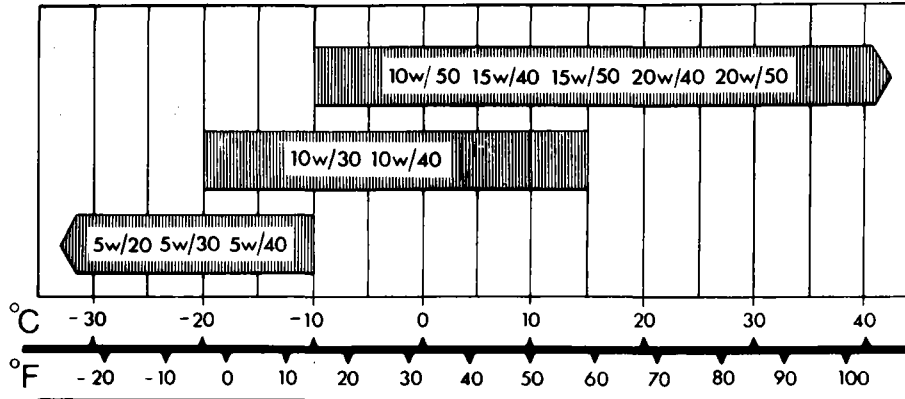

J09-001A

Component—Model	Temperature Range	Specification	S.A.E. Viscosity Rating	Approved Brands Available in U.K. for Temperatures Above -10°C (14°F)
Engine—All Models Distributor—All Models Oil Can—All models	Above -10°C (14°F) -20°C to 10°C (-4°F to 50°F) Below -10°C (14°F)	BLSO OL02 or MIL-L-2104 B or A.P.1. SE	10W/50, 15W/50, 20W/40, 20W/50 10W/30, 10W/40, 10W/50 5W/20, 5W/30	Unipart Super Multigrade, BP Super Viscostatic, Castrol GTX, Duckhams (15W/50) Hypergrade Motor Oil, Esso Uniflow, Fina Super Grade, Mobiloil Super, Shell Super Oil, Texaco Havoline
Manual Gearbox—6 cyl. —Refill —Top up ONLY	All All	Shell E3766 Hypoid Oil	75W EP 80 W	JRT Part No. RTC 1896
Powr-Lok Differential—All —Initial Fill —Refill	All All	Use only approved brands of fluid specially formulated for Powr-Lok	90 90	Shell Spirax Super 90, Shell Spirax Super 90, BP Gear Oil 1453, BP Limslip Gear Oil 90/1, Castrol G722, Castrol Hypoy LS, Duckhams Hypoid 90 DL, Texaco 3450 Gear Oil, Veedol Multigear Limited Slip S.A.E. 90
Drain and Top-Up —Top-up only if above oil not available Normal Differential—6 cyl. —Refill or top-up	All All	MIL-L-2105 B	EP 90	BP Gear Oil S.A.E. 90 EP, Castrol Hypoy, Duckhams Hypoid 90, Esso Gear Oil GX 90/140, Mobilube HDGO, Shell Spirax HD 90 Texaco Multigear Lubricant EP 90
GM 400 Automatic Transmission—12 cyl.	All	Dexron 2D		BP Autran DX, Castrol TQ Dexron, Esso ATF Dexron, Mobil ATF 220 Dexron, Shell ATF Dexron, Texaco Texamatic Fluid 6673
Borg-Warner Automatic Transmission Model 66 6 cyl.	All	Type G (M2C 33 G)	—	BP Autran G, Castrol TQF, Duckhams Q-Matic, Esso Glide Type G, Fina Purfimatic 33F, Mobil ATF 210, Shell Donax TF, Texaco Texamatic Type G
Power Assisted Steering—All	All	Above Specification or Dexron 2D	—	BP Autran DX, Castrol TQ Dexron, Esso ATF Dexron, Mobil ATF 220 Dexron, Shell ATF Dexron, Texaco Texamatic Fluid 6673
Grease Points—All	All	Multipurpose Lithium Grease, N.L.C.I. Consistency No. 2	—	BP Energrease L8, Castrol LM, Duckhams LB 10, Esso Multipurpose H, Fina Marson HTL2, Mobilgrease MP, Shell Retinax A, Texaco Marfak

## COOLING SYSTEM , CAPACITIES AND DIMENSIONS

### COOLING SYSTEM

Additive	<p>Jaguar Radiator Leak Sealer 2 135 ml bottles per vehicle – 12 cyl. 1 135 ml bottle per vehicle – 6 cyl.</p> <p>Barrs leaks 2 sachets per vehicle – 12 cyl. 1 sachet per vehicle – 6 cyl.</p>
Coolant	<p>Jaguar Anti-freeze/Coolant/Corrosion Inhibitor Concentration – 50%</p> <p>Canada/USA Jaguar Anti-freeze/Summer Coolant Concentration – 50%</p> <p>Australia JRA Limited Year Round Coolant Concentration – 33% to 50%</p> <p>Should these not be available then phosphate free anti-freeze conforming to specification BS6580 may be used.</p>
<p>Always top up the system with the recommended type and strength of coolant, NEVER with water only.</p>	

### CAPACITIES

	Litres	Imperial	U.S.
Engine refill (including filter)			
6 cylinder model .....			
Up to Vin nos. 8L161546; 8A15190; 7M4883 .....	8,25	14.5 pt	17.5 pt
From Vin nos. 8L161546; 8A15190; 7M4883 .....	8,81	15.5 pt	18.7 pt
12 cylinder model .....	10,8	19 pt	22.8 pt
Automatic transmission unit			
6 cylinder model (from dry) .....	8,00	14 pt	16.75 pt
12 cylinder model .....	9,1	16 pt	19.2 pt
Final drive unit .....	1,6	2.75 pt	3.25 pt
Cooling system, including reservoir and heater or air conditioning:			
6 cylinder model .....	18,2	32 pt	38.5 pt
12 cylinder model Not HE .....	21,2	37.5 pt	45 pt
HE .....	19,5	35 pt	42 pt
Fuel tanks – left and right – per tank .....	47,7	10.5 gal	12.6 gal
Luggage compartment .....	0,27 m <sup>3</sup>	9.55 ft <sup>3</sup>	9.55 ft <sup>3</sup>

### DIMENSIONS

Wheelbase .....	2865 mm	112.8 in
Track Front .....	1480 mm	58.26 in
Rear .....	1495 mm	58.86 in
Overall length: European cars .....	4959 mm	195.25 in
U.S.A. and Canada .....	5067 mm	199.5 in
Overall width .....	1770 mm	69.7 in
Overall height .....	1377 mm	54.2 in
Turning circle: between kerbs .....	12,2 mm	40 ft
Ground clearance: kerb condition .....	152,4 mm	6 in

**WEIGHTS**

U.K. and European Models	XJ 3.4		XJ 4.2 Daimler Sovereign		XJ 5.3 Daimler Sovereign	
	kg	lb	kg	lb	kg	lb
Kerb weight .....	1766	3902	1830	4044	1930	4265
Gross vehicle weight .....	2186	4831	2250	4973	2350	6294
*Gross train weight .....	3453	7631	3517	7773	3617	7994
Maximum permitted front axle load .....	1055	2332	1085	2398	1170	2580
Maximum permitted rear axle load .....	1150	2742	1180	2607	1200	2652
Federal Models	XJ 6		XJ 12			
	kg	lb	kg	lb		
Gross vehicle weight rating .....	2258	4979	2371	5229		
Gross axle weight rating—Front .....	1074	2370	1170	2580		
Gross axle weight rating—Rear .....	1183	2609	1201	2649		

\* Gross train weight is the gross vehicle weight plus maximum trailer weight.

**RECOMMENDED HYDRAULIC FLUID**

**Braking System**

Castrol-Girling Universal Brake and Clutch fluid. This fluid exceeds S.A.E. J1703/D specification.

**NOTE:** Check all pipes in the brake system at the start and finish of each winter period for possible corrosion due to salt and grit used on the roads.

**FUEL REQUIREMENTS**

**General**

The use of either leaded or unleaded fuel depends on the type of emission control system fitted to the engine and the legislative requirements in the country for which the vehicle is manufactured.

Vehicles with engines designed to use unleaded fuel are clearly marked 'UNLEADED FUEL ONLY' adjacent to the fuel filler cap.

Consult the vehicle handbook for the fuel type and octane rating to be used.

**Leaded Fuel**

All vehicles supplied for use in the United Kingdom and certain Overseas markets have engines which are designed to use leaded fuel only. It is important to realise that unleaded fuel although labelled 'PREMIUM' is not the same as 4-Star leaded fuel, and that THE USE OF FUEL WITH A LOWER OCTANE RATING CAN CAUSE SERIOUS ENGINE DAMAGE and could result in loss of warranty coverage.

Use leaded fuel with an octane rating of at least 97 in vehicles with high compression engines.

When refuelling, ensure that the petrol pump is clearly marked 'LEADED FUEL', if any doubt exists consult the service station operator for further advice.

**Unleaded Fuel**

Engines fitted with catalytic converters in the exhaust system are designed to use only unleaded fuel. Unleaded fuel must be used for the emission control system to operate properly. Its use will also reduce spark plug fouling, exhaust system corrosion and engine oil deterioration.

Using leaded fuel will damage the emission control system and could result in loss of warranty coverage. The effectiveness of the catalyst in the catalytic converter decreases after the use of as little as one tank of leaded fuel. Also, the vehicle is equipped with an electronic fuel injection system, which includes an oxygen sensor. Leaded fuel will damage the sensor, and deteriorate emission control.

Only petrol pumps delivering unleaded fuel have nozzles which fit the filler neck of the vehicle's fuel tank.

Using unleaded fuel with an octane rating lower than recommended can cause persistent, heavy 'spark knock' (a metallic rapping noise). If severe, this can lead to engine damage. However, occasional light 'spark knock' for a short time while accelerating or driving up hills may occur. Although this noise should not give cause for concern, it may be eliminated by the use of a fuel of a higher octane rating than that recommended.



### Unleaded Fuels Containing Alcohol

Some fuel suppliers sell fuel containing alcohol without advertising its presence. Where uncertainty exists check with the service station operator.

#### Ethanol:

Fuels containing up to 10% ethanol may be used. Ensure the fuel has octane ratings no lower than those recommended for unleaded fuel. Most driver's will not notice any operating difference with fuel containing ethanol, but some may, in which case the use of conventional unleaded fuel should be resumed if preferred.

#### Methanol:

Some fuels contain methanol (methyl or wood alcohol). DO NOT USE fuels containing methanol that do not also contain cosolvents and corrosion inhibitors for methanol. Also, DO NOT USE fuels that contain more than 3% methanol even if they contain cosolvents and corrosion inhibitors. Fuel system damage or vehicle performance problems resulting from the use of such fuels is not the responsibility of Jaguar Cars Limited and may not be covered under the warranty.

### Methyl Tertiary Butyl Ether (MTBE)

Unleaded fuel containing an oxygenate known as MTBE can be used provided the ratio of MTBE to petrol does not exceed 15%.

MTBE is an ether based compound, derived from petroleum, which has been specified by several refiners as the substance to enhance the octane rating of fuel.

Should driveability problems be encountered when using MTBE blended fuel, the use of conventional unleaded fuel should be resumed.

**CAUTION:** Take care to not spill fuel during refuelling. Fuel containing alcohol can cause paint damage, which may not be covered under the warranty.

### Components of Emission Control Systems

The component with most impact on the running of the vehicle is the catalytic converter which, when fitted, always requires the use of unleaded fuel.

The specifications of vehicles depend on the country legislation and/or option level chosen at the time of purchase.

### Exhaust Emission – Testing

In order that exhaust emissions are kept within the legislated limits, an exhaust emission test with the engine running at idling speed MUST be carried out after any unscheduled service operations which might affect the emission control system.

**MAINTENANCE SUMMARY—UK & Europe—Early Cars (up to VIN 322373)**

OPERATION	Interval in Kilometres x 1000	5	10	20
	Interval in Miles x 1000	3	6	12
<b>PASSENGER COMPARTMENT</b>				
Fit seat cover, place protective cover on carpets		X	X	X
Drive car on lift (ramp)		X	X	X
Check function of original equipment, i.e. interior and exterior lamps, indicators, horns and warning lights		X	X	X
Check operation of window controls		X	X	X
Check handbrake operation		X	X	X
Check footbrake operation		X	X	X
Check clock is running and set to time		X	X	X
Check windscreen washers and wipers for correct operation and that jets are clear and correctly positioned		X	X	X
Check condition and security of seats and seat belts		X	X	X
Check rear-view mirrors for cracks and crazing		X	X	X
<b>EXTERIOR AND LUGGAGE COMPARTMENT</b>				
Check door locks for correct operation		X	X	X
Check luggage compartment light for correct operation		X	X	X
Check/adjust tyre pressures, including spare		X	X	X
Check that tyres comply with manufacturer's specification		X	X	X
Check tyres for tread depth, visually for cuts in fabric, exposure of ply or cord structure, lumps or bulges		X	X	X
Check tightness of road wheel fastenings and that spare is correctly stowed		X	X	X
Check for fuel leaks at pumps and pipes; ensure that all connections are tight		X	X	X
Check front wheel alignment			X	X
Lubricate all locks and hinges (not steering lock)			X	X
Check, if necessary renew, windscreen wiper blades		X	X	X
Check/adjust headlight alignment		X	X	X
<b>ENGINE COMPARTMENT</b>				
Open bonnet, fit wing covers		X	X	X
Check/top-up engine oil		X		
Top-up carburettor piston dampers (where applicable)		X	X	X
Check/top-up cooling system		X	X	X
Check/top-up windscreen washer reservoir		X	X	X
Check/top-up brake fluid reservoir		X	X	X
Check/top-up clutch fluid reservoir		X	X	X
Check/top-up fluid in power steering reservoir		X	X	X
Check/top-up automatic gearbox fluid			X	X
Check distributor points; adjust or renew (where applicable)			X	X
Clean/adjust spark plugs			X	
Renew spark plugs				X
Lubricate distributor			X	X
Lubricate accelerator control linkage and check operation			X	X
Clean engine breather filter				X
Renew fuel filter				X
Clean A.E.D. unit filter (where applicable)		X	X	X
Renew air cleaner element and seal				X
Check/adjust torque of cylinder head nuts (not V12 engine)				X
Check/adjust torque of exhaust manifold nuts (not V12 engine)				X
Check/adjust ignition timing and distributor characteristics using electronic equipment			X	X
Check/adjust carburettor idle speed (where applicable)			X	X
Check/adjust driving bolts		X	X	X
Check/top-up battery electrolyte; clean and grease terminals		X	X	X
Check cooling and heating systems for leaks		X	X	X
Check visually hydraulic pipes and unions for chafing, leaks and corrosion		X	X	X
Check visually all joints for petrol, oil or air leaks		X	X	X
Check exhaust system for leakage and security		X	X	X

## MAINTENANCE

### MAINTENANCE SUMMARY – UK & EUROPE – Early Cars (up to VIN 322373)

OPERATION	Interval in Kilometres x 1000		5	10	20
	Interval in Miles x 1000		3	6	12
<b>UNDERBODY</b>					
<b>Raise ramp</b>					
Renew engine oil and filter .....			x	x	x
Check/top-up gearbox oil – cars fitted with manual transmission only .....				x	x
Check/top-up final drive oil .....				x	
Renew final drive oil .....					x
Check/adjust clutch push-rod free travel – cars fitted with manual transmission only .....				x	x
Lubricate clutch linkage .....				x	x
Lubricate automatic gearbox exposed selector linkage .....				x	x
Lubricate handbrake mechanical linkage and cable .....				x	x
Lubricate all grease points excluding hubs .....				x	x
Lubricate all grease points including hubs .....					x
Insert brake pads for wear and discs for condition .....	x		x	x	x
Check security of engine and suspension fixings .....					x
Check exhaust system for leakage and security .....	x		x	x	x
Check engine, power assisted steering, gearbox and final drive for oil leaks .....	x		x	x	x
Check condition and security of steering unit joints and gaiters .....	x		x	x	x
Check cooling and heating system for leaks .....				x	x
Check visually hydraulic pipes and unions for chafing, leaks and corrosion .....	x		x	x	x
Check visually all joints for petrol, oil or air leaks .....	x		x	x	x
Check/adjust tyre pressures .....	x		x	x	x
<b>Lower ramp</b>					
Remove wing covers, close bonnet and check bonnet for correct operation .....			x	x	x
<b>ROAD OR DYNAMOMETER TEST</b>					
(Clean hands before carrying out following items)					
<b>Ensure that seat cover and protective cover on carpets are in place .....</b>					
<b>Drive car off lift (ramp) .....</b>			x	x	x
Carry out road/roller test and check function of all instrumentation. Check safety					
harness inertia reel mechanism .....			x	x	x
Remove seat cover and protective cover from carpets .....			x	x	x

### ADDITIONAL MAINTENANCE OPERATIONS – ALL VEHICLES

#### Brake System – Preventive Maintenance

In addition to the periodical inspection of brake components it is advisable as the car ages and as a precaution against the effects of wear and deterioration to make a more searching inspection and renew parts as necessary.

It is recommended that:

1. Disc brake pads, hoses and pipes should be examined at intervals no greater than those laid down in the Passport to Service.
2. Brake fluid should be changed completely every two years.
3. All fluid seals in the hydraulic system should be renewed and all flexible hoses should be examined and renewed if necessary every three years or 96 000 km (60 000 miles) whichever is the sooner. At the same time the working surfaces of the pistons and the bores of the master cylinder, wheel cylinders

and other slave cylinders should be examined and new parts fitted where necessary.

Care should be taken to observe the following:

- a. At all times use the recommended brake fluid.
- b. Never leave fluid in unsealed containers; it absorbs moisture quickly and can be dangerous if used in the braking system in this condition.
- c. Fluid drained from the system or used for bleeding is best discarded.
- d. The necessity for absolute cleanliness when carrying out any operations on the braking system cannot be over-emphasized.

**MAINTENANCE SUMMARY — UK & EUROPE — Later Cars (from VIN 322374)**

OPERATION	Interval in Kilometres x 1000	1.5	12	24
	Interval in Miles x 1000	1	7.5	15
Fit protection kit .....		x	x	x
Check condition and security of seats and seat belts .....		x	x	x
Check operation of seat belt warning system .....		x		
Check footbrake operation .....		x	x	x
Check operation of lamps .....		x		
Check operation of horns .....		x		
Check operation of warning indicators .....		x		
Check operation of windscreen wipers .....		x		
Check operation of windscreen washers .....		x		
Check security of handbrake – release fully after checking .....		x	x	x
Check rear-view mirrors for security and function .....		x		
Mark stud to wheel relationship .....			x	x
Remove front wheels .....			x	
Remove road wheels – front and rear .....				x
Check that tyres are of the correct size and shape .....		x	x	x
Check tyre tread depth .....		x	x	x
Check tyres visually for external lumps, bulges and uneven wear .....		x	x	x
Check tyres visually for external exposure of ply or cord .....		x	x	x
Check/adjust tyre pressures .....		x	x	x
Inspect brake pads for wear and discs for condition .....			x	x
Adjust front hub bearing end-float .....				x
Grease hubs (up to VIN 481999) .....				x
Check for oil leaks from steering and fluid leaks from suspension system .....		x	x	x
Check condition and security of steering unit joints and gaiters .....		x	x	x
Refit road wheels in original position .....			x	x
Check tightness of road wheel fastenings .....		x	x	x
Drain engine oil .....		x	x	x
Check/top up gearbox oil (manual) .....		x	x	x
Renew automatic transmission filter 48 000 km (30 000 miles) .....				48 km
Renew automatic transmission fluid 48 000 km (30 000 miles) .....				48 km
Grease all points excluding hubs .....			x	x
Check/top up rear axle/final drive oil .....		x	x	x
Renew final drive oil 48 000 km (30 000 miles) .....				48 km
Check visually hydraulic hoses, pipes and unions for chafing, cracks, leaks and corrosion .....		x	x	x
Check exhaust system for leakage and security .....		x	x	x
Lubricate handbrake mechanical linkage and cables .....		x	x	x
Check condition of handbrake pads .....				x
Lubricate automatic gearbox exposed selector linkage .....		x	x	x
Check tightness of propshaft coupling bolts .....		x		x
Check security of accessible engine mountings .....		x		
Check condition and security of steering unit, joints and gaiters .....		x	x	x
Check security and condition of suspension fixings .....		x	x	x
Check steering rack for oil leaks .....		x	x	x
Check power steering for leaks, hydraulic pipes and unions for chafing, corrosion and security .....		x	x	x
Check shock absorbers for fluid leaks .....		x	x	x
Renew engine oil filter element .....			x	x
Refit engine drain plug .....		x	x	x
Check for oil leaks – engine and transmission .....		x	x	x

# MAINTENANCE

## MAINTENANCE SUMMARY — UK & Europe — Later Cars

OPERATION	Interval in Kilometres x 1000		1.5	12	24
	Interval in Miles x 1000		1	7.5	15
Check/adjust torque of cylinder head nuts/bolts (not V12 engine)			x		
Fill engine with oil			x	x	x
Lubricate accelerator control linkage and pedal pivot			x		
Top up carburetter piston dampers (where applicable)			x	x	x
Renew air cleaner element(s)					x
Check security of accessible engine mountings			x		
Check driving belts; adjust or renew			x		x
Clean and adjust spark plugs				x	
Renew spark plugs					x
Check/top-up battery electrolyte (where applicable)			x	x	x
Clean and grease battery connections			x	x	x
Check/top-up clutch fluid reservoir (where applicable)			x	x	x
Check/top-up brake fluid reservoir			x	x	x
Check brake servo hose(s) for security and condition			x	x	x
Check/top-up windscreen washer reservoir			x		
Check cooling and heater system for leaks and hoses for security and condition			x	x	x
Change coolant ensuring the correct antifreeze concentration 48.000 km (30 000 miles)					48 km
Check/top-up cooling system			x		
Renew fuel filter — 3.4					x
Clean engine breather filter (where applicable)					x
Check crankcase breathing system for leaks, hoses for security and condition			x		x
Clean A.E.D. filter (where applicable)			x	x	x
Check/top-up fluid in power steering reservoir; check security and condition of oil pressure hose at oil filter			x	x	x
Run engine and check for sealing of oil filter; stop engine				x	x
Check/top-up engine oil				x	x
Connect electronic instruments and check underbonnet label data			x		x
Check visually distributor points; adjust or renew (where applicable)			x		
Renew distributor points (where applicable)					x
Lubricate distributor (not cam wiping pad) V12 at 36.000 km (22 500 miles)			x		36 km
Disconnect vacuum pipe, check dwell angle, adjust as necessary			x		x
Check ignition timing (at normal operating temperature on HE models)			x	x	x
Check distributor automatic advance			x		x
Check advance increases as vacuum pipe is reconnected			x		x
Lubricate all locks, hinges and door check mechanisms (not steering lock)			x		x
Check operation of bonnet lock and boot and door locks and lights			x		
Check operation of window controls			x		
Check and if necessary renew windscreen wiper blades				x	x
Check/adjust engine idle speed and carburetter mixture settings (where applicable) stop engine — disconnect instruments			x		x
Check power steering system for leaks, hydraulic pipes and unions for chafing and corrosion			x	x	x
Check for oil leaks from engine and transmission			x	x	x
Check/top-up automatic gearbox fluid			x	x	x
Re-check tension if driving belt has been renewed			x		x
Remove spare wheel			x	x	x
Check that the tyre is the correct size and type			x	x	x
Check tyre tread depth			x	x	x

**MAINTENANCE SUMMARY — UK & EUROPE — Later Cars**

OPERATION	Interval in Kilometres x 1000		1.5	12	24
	Interval in Miles x 1000		1	7.5	15
Check tyre visually for external exposure of cord or ply .....			x	x	x
Check tyre visually for external lumps or bulges .....			x	x	x
Check/adjust tyre pressure .....			x	x	x
Renew fuel filter (not 3.4) .....					x
Refit spare wheel .....			x	x	x
Check/adjust headlamp alignment .....			x		x
Check/adjust front wheel alignment .....			x		x
Carry out road or roller test .....			x	x	x
Check operation of seat belt inertia mechanism .....			x	x	x
Ensure cleanliness of controls, door handles, steering wheel, etc .....			x	x	x
Remove protection kit .....			x	x	x
Report additional work required .....			x	x	x

**It is further recommended:**

**At 24 month intervals:**

Change brake fluid.

**At 96 000 km (60 000 mile) or 36 month intervals:**

Renew all fluid seals in hydraulic system; examine and renew if necessary all flexible hoses.

Examine working surfaces of master cylinder and calipers. Renew if necessary.

**OPTIONAL SERVICES**

OPERATION	Interval in Kilometres x 1000		12	24
	Interval in Miles x 1000		7.5	15
Check operation of lamps .....				x
Check operation of horns .....				x
Check operation of warning indicators .....				x
Check operation of windscreen wipers .....				x
Check operation of windscreen washers .....				x
Check operation of window controls .....			x	x
Check operation of boot lamp .....				x
Check operation of all door, bonnet and boot locks .....			x	x
Check sunroof and controls for correct operation (if fitted) .....				x
Check operation of headlamp wipe/wash (if fitted) .....				x
Check rear view mirrors for security and function .....				x
Check/top-up windscreen washer reservoir .....				x
Check/top-up cooling system .....			x	x
Lubricate all locks, hinges and door check mechanisms (not steering lock) .....			x	
Check operation of cruise control (if fitted) .....				x
Clean aerial mast .....			x	
Check/adjust headlamp alignment .....			x	
Check/adjust front wheel alignment .....			x	

# MAINTENANCE

## MAINTENANCE SUMMARY — North American Markets

Service Code Letter	DISTANCE Mileage x 1000													
	A	1												
B		7.5		22.5		37.5		52.5		67.5		82.5		97.5
C			15				45				75			
D					30				60				90	

**THE PERIOD BETWEEN SERVICES SHOULD NOT EXCEED 12 MONTHS**

**Maintenance, replacement or repair of the emission control devices and system may be performed by an automotive repair establishment or individual using any automotive part which has been certified by the part manufacturer. Your dealer will supply particulars.**

**MAINTENANCE SUMMARY North American Markets****1000 MILES  
A INTERVAL****LUBRICATION**

Lubricate handbrake mechanical linkage and cables  
Renew engine oil and engine oil filter  
Check/top-up rear axle oil  
Check/top-up brake fluid reservoir  
Check/top-up automatic transmission fluid  
Check battery condition/clean and grease connections if necessary  
Check/top-up cooling system  
Check/top-up power steering reservoir  
Check/top-up windscreen washer fluid  
Lubricate all locks and hinges (not steering lock)  
Renew fluid — manual transmission  
Check/top-up clutch fluid

**ENGINE**

Check for oil leaks  
Check all driving belts; adjust  
Check cooling and heater system for leaks, for hose condition and security  
Check security of engine mountings

**FUEL AND EXHAUST SYSTEMS**

Check fuel system for leaks, pipes and unions for chafing and corrosion  
Check exhaust system for leaks and security

**TRANSMISSION, BRAKES, STEERING  
AND SUSPENSION**

Check for fluid/oil leaks  
Check condition and security of steering unit, joints and gaiters  
Check visually brake hydraulic pipes and unions for cracks, chafing, leaks and corrosion  
Check suspension component condition and security  
Check shock absorbers for leaks and condition  
Check/adjust wheel alignment  
Check brake servo hoses for security and condition  
Check footbrake and handbrake operation

**WHEELS AND TYRES**

Check that tyres comply with manufacturer's specification  
Check tyres for tread depth and visually for external cuts in fabric, exposure of ply or cord structure, lumps or bulges  
Check tyres for irregular tread wear; perform necessary alignment/repair  
Check and adjust tyre pressure, including spare wheel  
Check for damaged/deformed wheel rims  
Check tightness of road wheel fastenings

**ELECTRICAL**

Check/adjust operation of windscreen wipers and washers  
Check function of all original equipment: lights, horns, warning indicators, radio, etc.  
Check/adjust headlight alignment (refer to state and local requirement)

**BODY**

Check operation and security of seats and seat belts — front and rear  
Check operation of all door, bonnet and boot locks  
Check operation of window and sunroof controls  
Check/open underbody drains (also during annual rust inspection)

**GENERAL****Road Test:**

Check vehicle performance, shifting, braking, handling  
Check function of all instrumentation  
Check function of trip computer  
Check function of cruise control  
Check function of climate control and ventilation systems

**Report Additional Work Required  
After Road Test:**

Check engine for leaks  
Check/top-up automatic transmission fluid  
Check/top-up brake fluid reservoir  
Check/top-up power steering reservoir



## MAINTENANCE

---

### MAINTENANCE SUMMARY North American Markets

#### 7500 MILES B INTERVAL

##### LUBRICATION

Lubricate all grease points (not wheel hubs or steering rack)  
Lubricate handbrake mechanical linkage and cables  
Renew engine oil and engine oil filter  
Check/top-up rear axle oil  
Check/top-up brake fluid reservoir  
Check/top-up automatic transmission fluid  
Check battery condition/clean and grease connections if necessary  
Check/top-up cooling system  
Check/top-up power steering reservoir  
Check/top-up windscreen washer fluid  
Lubricate all locks and hinges (not steering lock)  
Renew brake fluid every 18 000 miles or 18 months  
Renew coolant every 2 years  
Check/top-up clutch fluid

##### ENGINE

Check for oil leaks  
Check all driving belts; adjust/renew as necessary (applicable above 30 000 miles)  
Check cooling and heater system for leaks, for hose condition and security

##### FUEL AND EXHAUST SYSTEMS

Check fuel system for leaks, pipes and unions for chafing and corrosion  
Check exhaust system for leaks and security  
Renew fuel filter (at 52 500 miles only)

##### TRANSMISSION, BRAKES, STEERING AND SUSPENSION

Check for fluid/oil leaks  
Check condition and security of steering unit, joints and gaiters  
Check visually brake hydraulic pipes and unions for cracks, chafing, leaks and corrosion  
Check suspension component condition and security  
Check shock absorbers for leaks and condition  
Inspect brake pads for wear and discs for condition (including handbrake pads)  
Check/adjust wheel alignment  
Check brake servo hoses for security and condition

##### WHEELS AND TYRES

Check that tyres comply with manufacturer's specification  
Check tyres for tread depth and visually for external cuts in fabric, exposure of ply or cord structure, lumps or bulges  
Check tyres for irregular tread wear; perform necessary alignment/repair  
Check and adjust tyre pressure, including spare wheel  
Check for damaged/deformed wheel rims  
Check tightness of road wheel fastenings

##### ELECTRICAL

Check/adjust operation of windscreen wipers and washers  
Check function of all original equipment: lights, horns, warning indicators, radio, etc.  
Check wiper blades and arms: renew if necessary  
Check/adjust headlight alignment (refer to state and local requirement)

##### BODY

Check operation and security of seats and seat belts — front and rear  
Check operation of all door, bonnet and boot locks  
Check operation of window and sunroof controls  
Check/open underbody drains (also during annual rust inspection)

##### GENERAL

###### Road Test:

Check vehicle performance, shifting, braking, handling  
Check function of all instrumentation  
Check function of trip computer  
Check function of cruise control  
Check function of climate control and ventilation systems

###### Report Additional Work Required After Road Test:

Check engine for leaks  
Check/top-up automatic transmission fluid  
Check/top-up brake fluid reservoir  
Check/top-up power steering reservoir

**MAINTENANCE SUMMARY North American Markets**

**15 000 MILES  
C INTERVAL**

**LUBRICATION**

- Lubricate all grease points
- Lubricate handbrake mechanical linkage and cables
- Lubricate front/rear wheel hubs
- Lubricate steering rack (hand operated equipment only)
- Renew engine oil and engine oil filter
- Renew manual transmission fluid
- Check/top-up rear axle oil
- Check/top-up brake fluid reservoir
- Check/top-up automatic transmission fluid
- Check battery condition/clean and grease connections if necessary
- Check/top-up cooling system
- Check/top-up power steering reservoir
- Check/top-up windscreen washer fluid
- Lubricate accelerator control linkages and pedal pivot; check operation
- Lubricate all locks and hinges (not steering lock)
- Renew brake fluid every 18 000 miles or 18 months
- Renew coolant every 2 years
- Check/top-up clutch fluid

**ENGINE**

- Check for oil leaks
- Check all driving belts; adjust/renew as necessary (applicable above 30 000 miles)
- Check cooling and heater system for leaks, for hose condition and security

**FUEL AND EXHAUST SYSTEMS**

- Check fuel system for leaks, pipes and unions for chafing and corrosion
- Check exhaust system for leaks and security

**TRANSMISSION, BRAKES, STEERING  
AND SUSPENSION**

- Check for fluid/oil leaks
- Check condition and security of steering unit, joints and gaiters
- Check visually brake hydraulic pipes and unions for cracks, chafing, leaks and corrosion
- Check suspension component condition and security
- Check shock absorbers for leaks and condition
- Inspect brake pads for wear and discs for condition (including handbrake pads)
- Check/adjust front wheel alignment
- Check/adjust front hub bearing end float
- Check tightness of propeller shaft coupling bolts
- Check brake servo hoses for security and condition

**WHEELS AND TYRES**

- Check that tyres comply with manufacturer's specification
- Check tyres for tread depth and visually for external cuts in fabric, exposure of ply or cord structure, lumps or bulges
- Check tyres for irregular tread wear; perform necessary alignment/repair
- Check and adjust tyre pressure, including spare wheel
- Check for damaged/deformed wheel rims
- Check tightness of road wheel fastenings

**ELECTRICAL**

- Check/adjust operation of windscreen wipers and washers
- Check function of all original equipment: lights, horns, warning indicators, radio, etc.
- Check wiper blades and arms; renew if necessary
- Check/adjust headlight alignment (refer to state and local requirement)

**BODY**

- Check operation and security of seats and seat belts — front and rear
- Check operation of all door, bonnet and boot locks
- Check operation of window and sunroof controls
- Check/open underbody drains (also during annual rust inspection)

**GENERAL**

**Road Test:**

- Check vehicle performance, shifting, braking, handling
- Check function of all instrumentation
- Check function of trip computer
- Check function of cruise control
- Check function of climate control and ventilation systems

**Report Additional Work Required**

**After Road Test:**

- Check engine for leaks
- Check/top-up automatic transmission fluid
- Check/top-up brake fluid reservoir
- Check/top-up power steering reservoir

## MAINTENANCE

### MAINTENANCE SUMMARY North American Markets

#### 30 000 MILES D INTERVAL

##### LUBRICATION

Lubricate all grease points  
Lubricate handbrake mechanical linkage and cables  
Lubricate front/rear wheel hubs  
Lubricate steering rack (hand operated equipment only)  
Renew engine oil and engine oil filter  
Renew automatic transmission fluid (and filter GM400) (clean screen BW)  
Check/top-up rear axle oil  
Check/top-up brake fluid reservoir  
Check/top-up manual transmission fluid  
Check battery condition/clean and grease connections if necessary  
Check/top-up cooling system  
Check/top-up power steering reservoir  
Check/top-up windscreen washer fluid  
Lubricate accelerator control linkage and pedal pivot; check operation  
Lubricate distributor  
Lubricate all locks and hinges (not steering lock)  
Renew brake fluid every 18 000 miles or 18 months  
Renew coolant every 2 years  
Check/top-up clutch fluid

##### ENGINE

Check for oil leaks  
Renew air cleaner element(s)  
Renew spark plugs  
Check all driving belts; adjust/renew as necessary (applicable above 30 000 miles)  
Check cooling and heater system for leaks, for hose condition and security  
Check crankcase breathing and evaporative loss control system

##### FUEL AND EXHAUST SYSTEMS

Check fuel system for leaks, pipes and unions for chafing and corrosion  
Check exhaust system for leaks and security  
Renew oxygen sensor(s)

##### TRANSMISSION, BRAKES, STEERING AND SUSPENSION

Check for fluid/oil leaks  
Check condition and security of steering unit, joints and gaiters  
Check visually brake hydraulic pipes and unions for cracks, chafing, leaks and corrosion  
Check suspension component condition and security  
Check shock absorbers for leaks and condition  
Inspect brake pads for wear and discs for condition (including handbrake pads)  
Check/adjust front wheel alignment  
Check/adjust front hub bearing end float  
Check tightness of propeller shaft coupling bolts  
Check brake servo hoses for security and condition

##### WHEELS AND TYRES

Check that tyres comply with manufacturer's specification  
Check tyres for tread depth and visually for external cuts in fabric, exposure of ply or cord structure, lumps or bulges  
Check tyres for irregular tread wear; perform necessary alignment/repair  
Check and adjust tyre pressure, including spare wheel  
Check for damaged/deformed wheel rims  
Check tightness of road wheel fastenings

##### ELECTRICAL

Check/adjust operation of windscreen wipers and washers  
Check function of all original equipment: lights, horns, warning indicators, radio, etc.  
Check wiper blades and arms; renew if necessary  
Check/adjust headlight alignment (refer to state and local requirement)

##### BODY

Check operation and security of seats and seat belts — front and rear  
Check operation of all door, bonnet and boot locks  
Check operation of window and sunroof controls  
Check/open underbody drains (also during annual rust inspection)

##### GENERAL

###### Road Test:

Check vehicle performance, shifting, braking, handling  
Check function of all instrumentation  
Check function of trip computer  
Check function of cruise control  
Check function of climate control and ventilation systems

###### Report Additional Work Required After Road Test:

Check engine for leaks  
Check/top-up automatic transmission fluid  
Check/top-up brake fluid reservoir  
Check/top-up power steering reservoir

SERVICE TOOLS – SECTION 11 – 6 CYLINDER ENGINE – SECTION 12

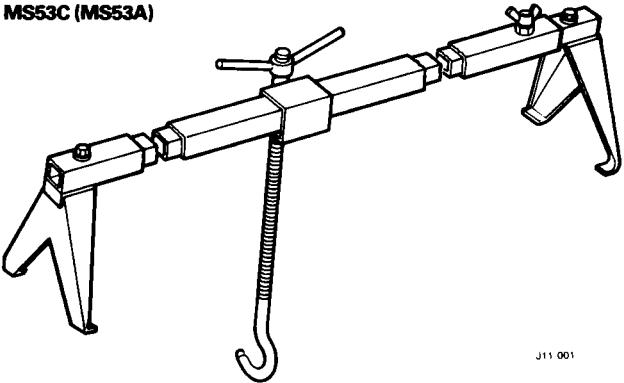
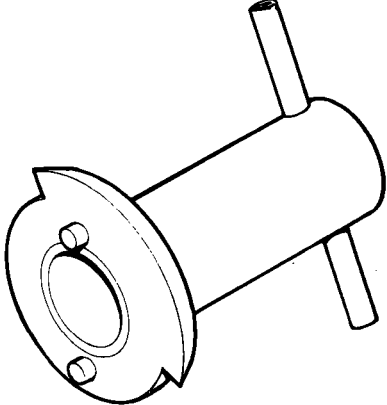
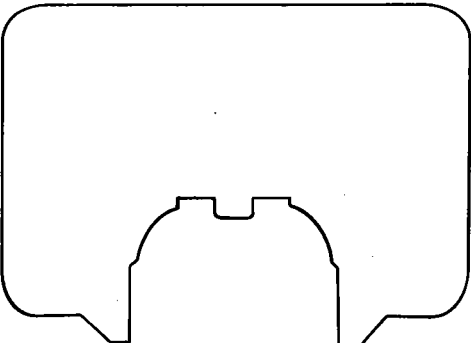
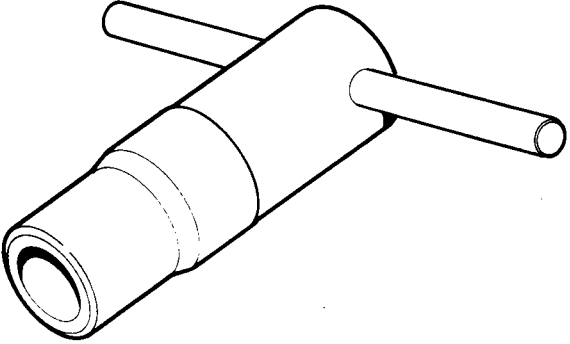
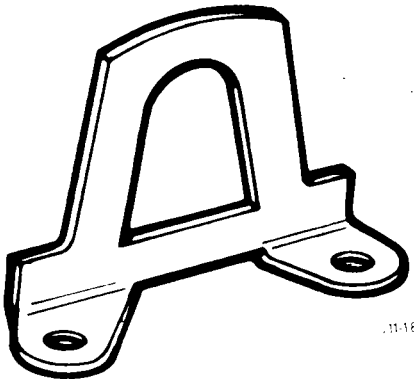
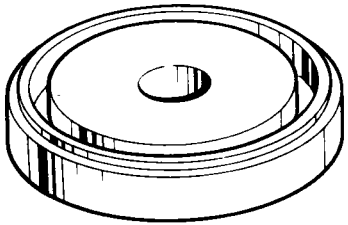
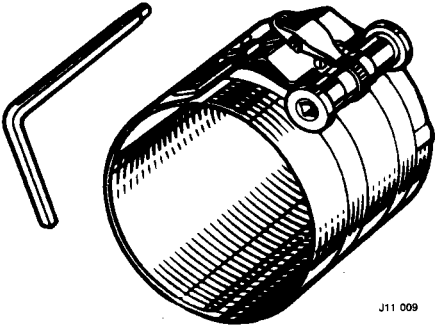
<p><b>MS53C (MS53A)</b></p>  <p>J11 001</p> <p>Engine support bracket</p>	<p><b>JD 2B</b></p>  <p>J11-178</p> <p>Timing chain adjusting plate</p>
<p><b>C 3993</b></p>  <p>J11 025</p> <p>Valve and Timing gauge</p>	<p><b>JD 17B</b></p>  <p>Oil seal packing presizing tool</p>
<p><b>*C37851</b></p>  <p>J11-183</p> <p>Lifting eye</p>	<p><b>JD 6118C</b></p>  <p>J11 114</p> <p>Valve spring compressor</p>
<p><b>18G 55A (38U3)</b></p>  <p>J11 009</p> <p>Piston ring compressor</p>	

**SERVICE TOOLS**

**12 CYLINDER ENGINE – SECTION 12**

**MS53C (MS 53A)**

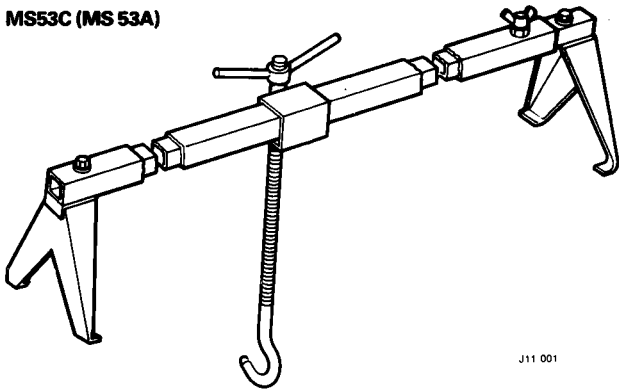

J11 001

Engine support bracket

**JD 17B-1**

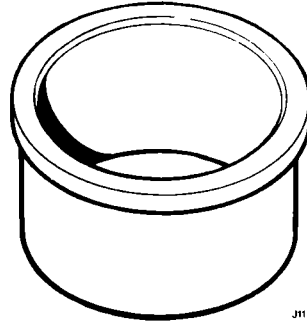

J11 106

Adaptor crankshaft rear oil seal presizing tool

**\*C 3993**

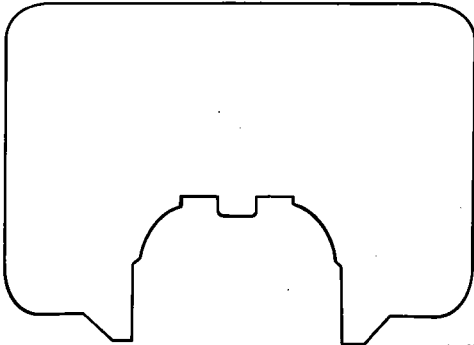

J11 025

Valve and Timing gauge

**JD 38**

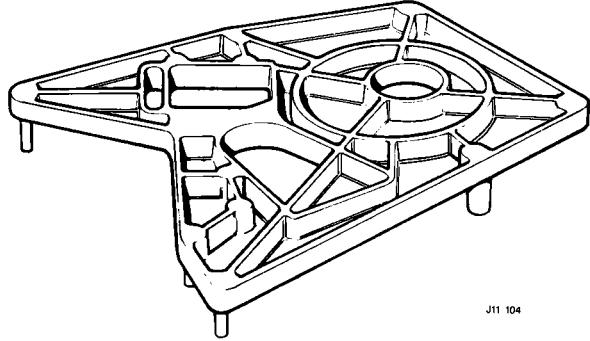

J11 104

Damper setting jig

**18G.55A (38U3)**

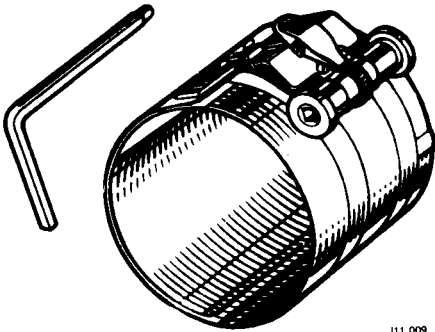

J11 009

Piston ring compressor

**JD 39**

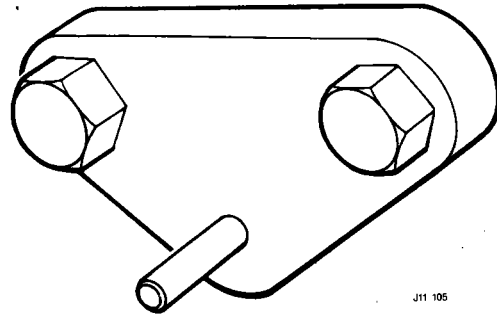

J11 105

Jackshaft sprocket holder

**JD 17B**

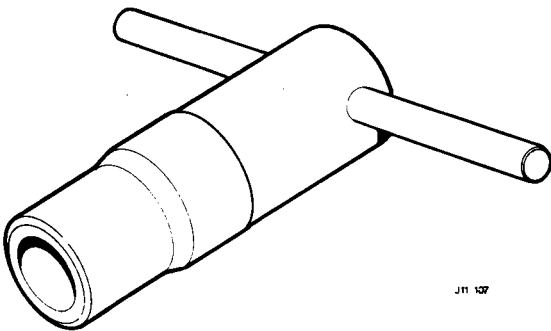

J11 107

Oil seal packing presizing tool

**JD 40**

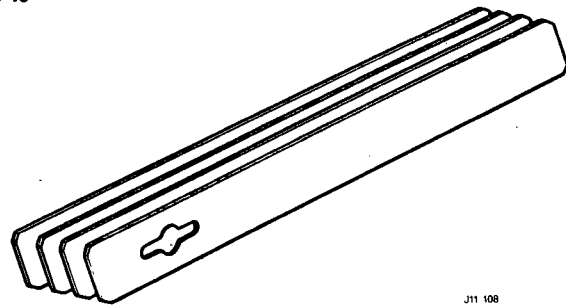

J11 108

Camshaft sprocket retainer

12 CYLINDER ENGINE – SECTION 12 – continued

JD 41

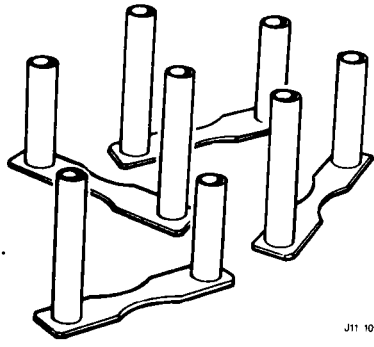

Cylinder liner retainers

JD 50

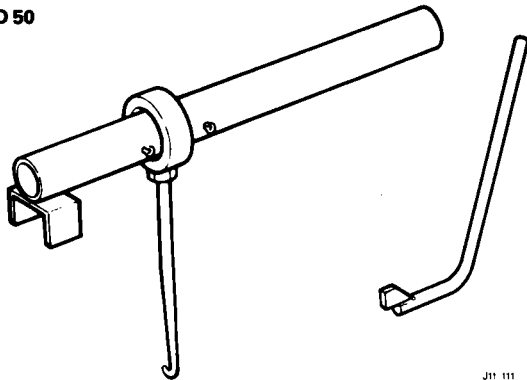

Timing chain tensioner retainer

JD 6119C

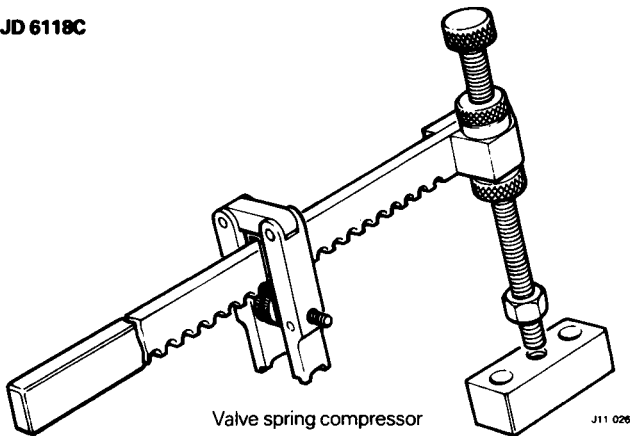

Valve spring compressor

**SERVICE TOOLS**

**FUEL SYSTEM – SECTION 19**

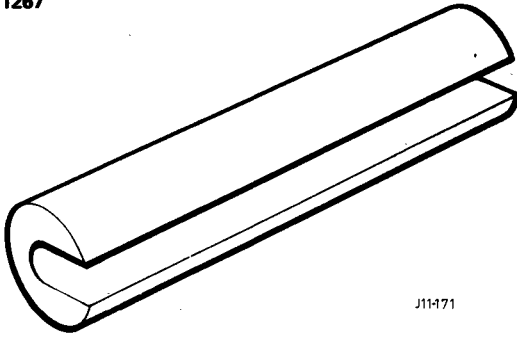
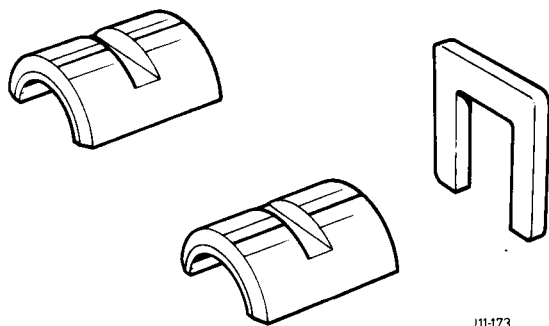
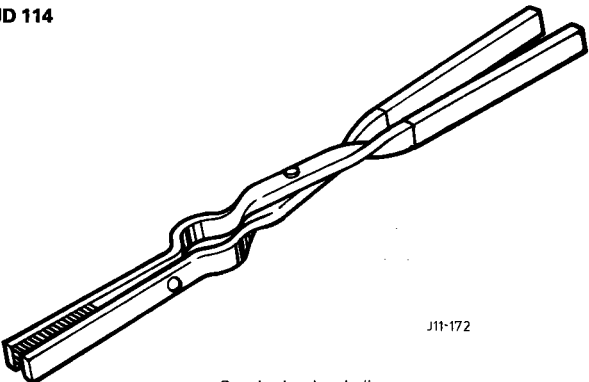
<p><b>18G 1267</b></p>  <p>J11-171</p> <p>Replacer – Damper assembly retainer</p>	<p><b>JD 116</b></p>  <p>J11-173</p> <p>Injector hose fitting tool</p>
<p><b>JD 114</b></p>  <p>J11-172</p> <p>Spark plug lead pliers</p>	

**MANUAL GEARBOX – SECTION 37**

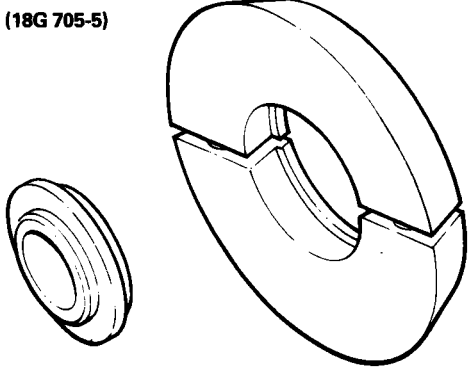
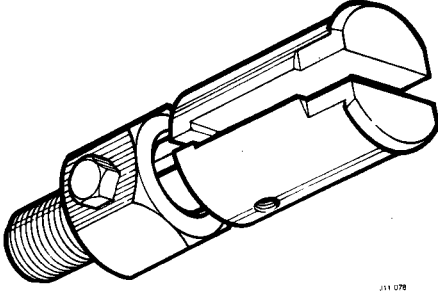
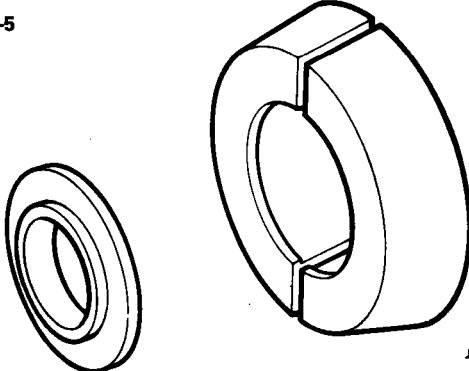
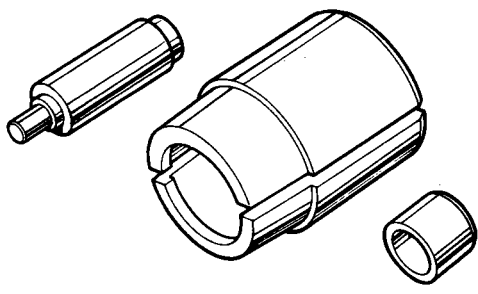
<p><b>18G 47-1 (18G 705-5)</b></p>  <p>J11-147</p> <p>Adaptor – remover, layshaft cluster bearings</p>	<p><b>18G 284AAH</b></p>  <p>J11-078</p> <p>Adaptor/remover – mainshaft pilot bearing outer track</p>
<p><b>18G 47-5</b></p>  <p>J11-168</p> <p>Adaptor remover/replacer constant pinion bearing</p>	<p><b>18G 705-1A</b></p>  <p>J11-179</p> <p>Adaptor/remover 5th speed gear</p>

MANUAL GEARBOX – SECTION 37 – continued

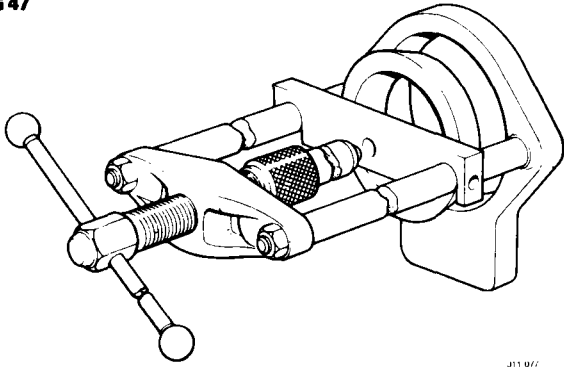
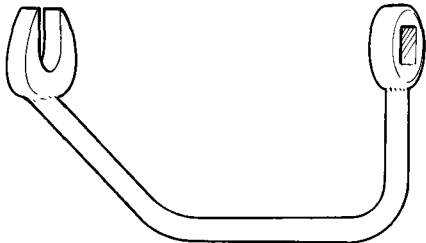
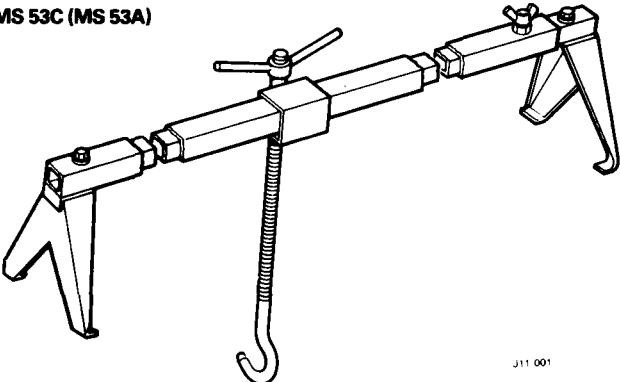
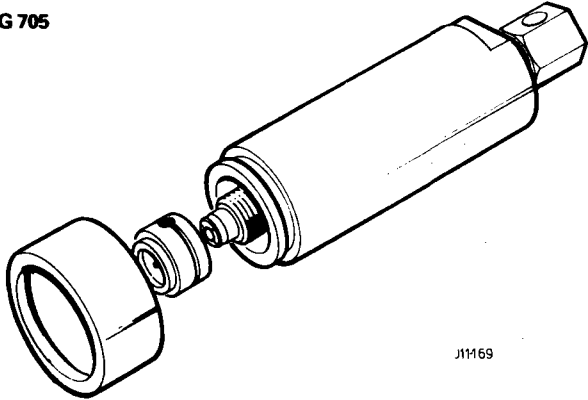
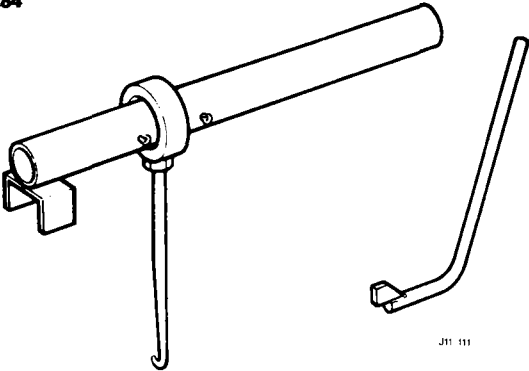
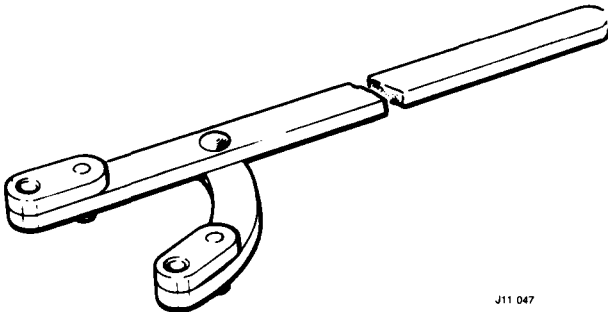
<p><b>18G 47</b></p>  <p>J11 077</p> <p>Multi-purpose handpress</p>	<p><b>#ST1136</b></p>  <p>J11-187</p> <p>Offset spanner</p>
<p><b>MS 53C (MS 53A)</b></p>  <p>J11 001</p> <p>Engine support bracket</p>	<p><b>18G 705</b></p>  <p>J11169</p> <p>Remover bearing race centre</p>
<p><b>18G 284</b></p>  <p>J11 111</p> <p>Impulse extractor</p>	
<p><b>18G 1205</b></p>  <p>J11 047</p> <p>Propellor shaft flange wrench</p>	



**SERVICE TOOLS**

**AUTOMATIC TRANSMISSION – BORG-WARNER MODEL 66 – SECTION 44BW**

**CBW 1C**

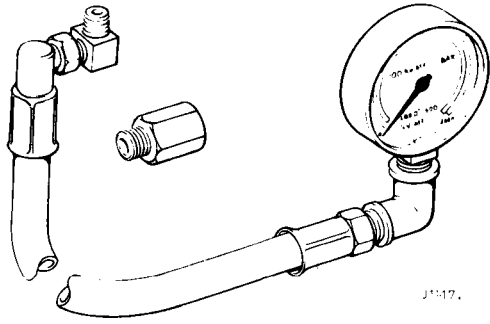

J11-17

Hydraulic pressure test equipment

**MS 53C MS 53A**

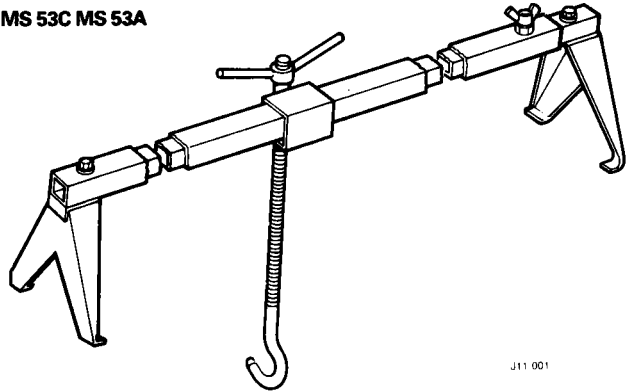

J11-001

Engine support bracket

**CBW 1C-5**

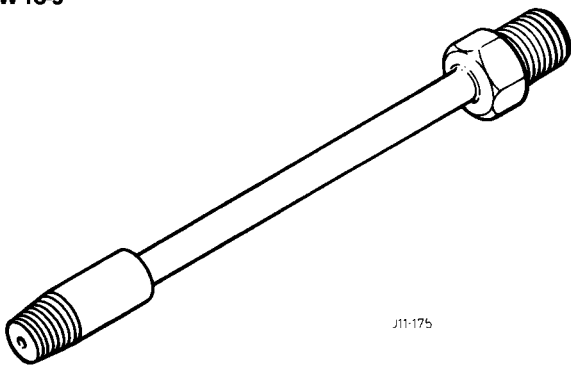

J11-17b

Adaptor – pressure test

**CBW 62**

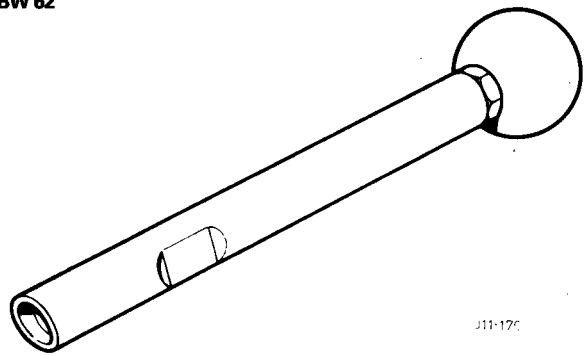

J11-17c

Remover – throttle cable mounting seal

**CBW 87**

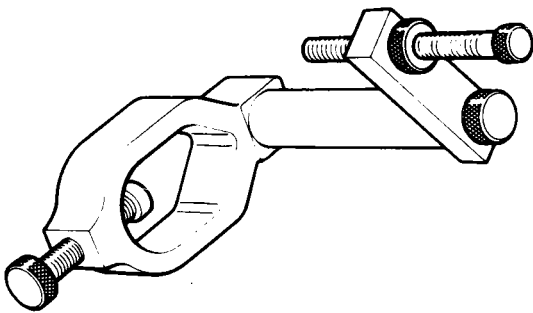

J11-177

End float checking gauge

**CBW 547B-30 (CBW 547B-75)**

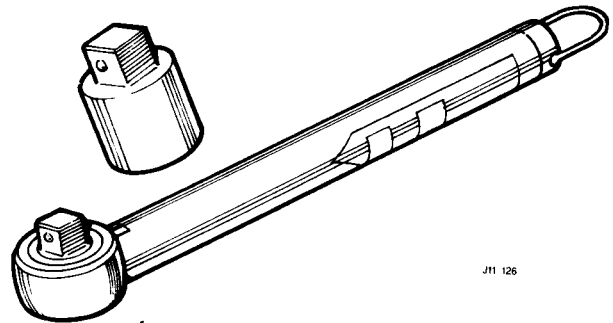

J11-126

Tension wrench

**18G 681**

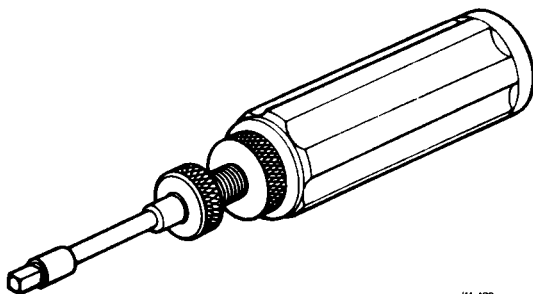

J11-128

Torque screwdriver

**CBW 547-50-2A**

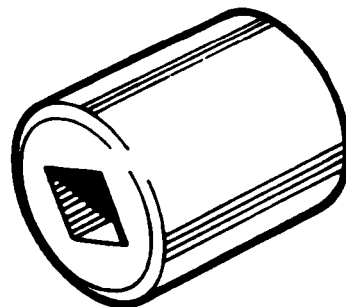

J11-167

Rear servo adjuster adaptor

AUTOMATIC TRANSMISSION – BORG-WARNER MODEL 66 – SECTION 44BW Continued

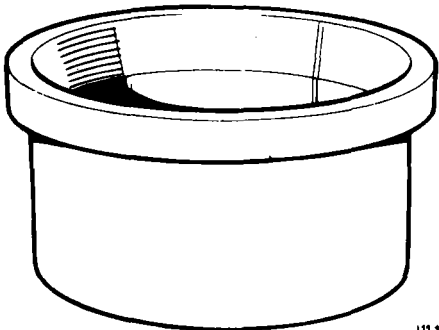
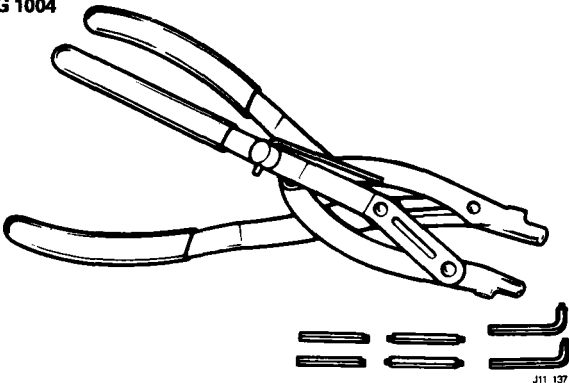
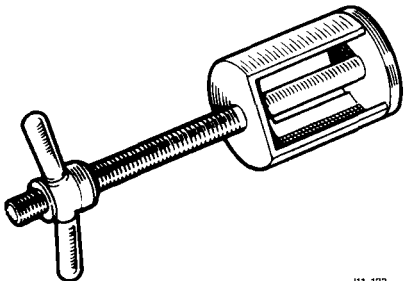
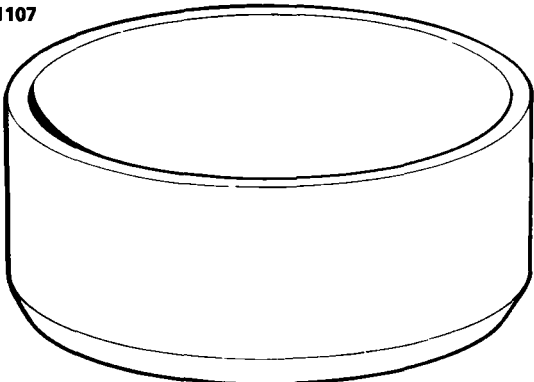
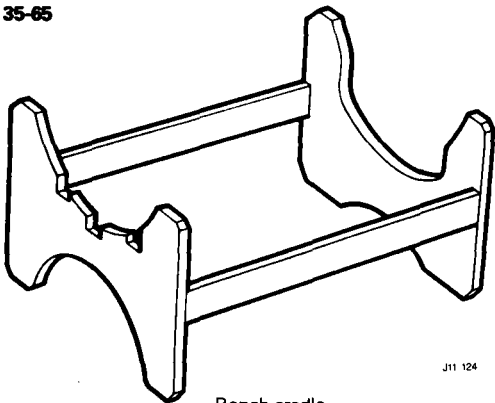
<p><b>18G 702</b></p>  <p>J11 166</p> <p>Replacer rear clutch piston</p>	<p><b>18G 1004</b></p>  <p>J11 137</p> <p>Circclip pliers</p>
<p><b>18G 1016 (JD 107)</b></p>  <p>J11 123</p> <p>Clutch spring compressor</p>	<p><b>18G 1107</b></p>  <p>J11-191</p> <p>Replacer – front clutch piston</p>
<p><b>CBW 35-65</b></p>  <p>J11 124</p> <p>Bench cradle</p>	

**SERVICE TOOLS**

**AUTOMATIC TRANSMISSION – GM 400 – SECTION 44GM**

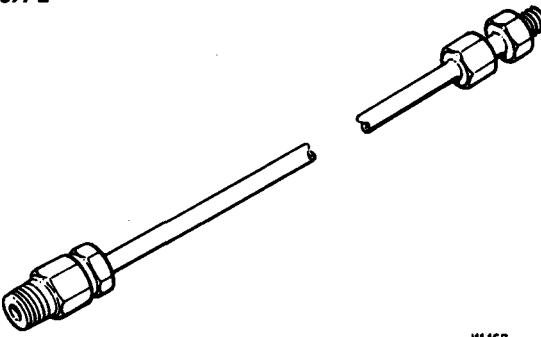
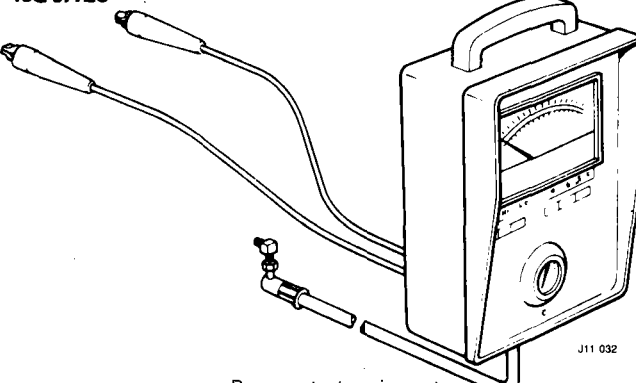
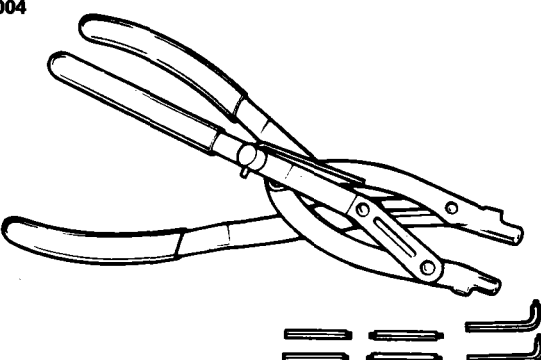
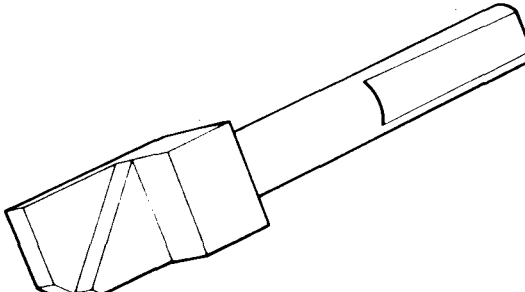
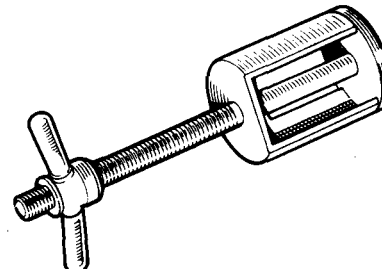
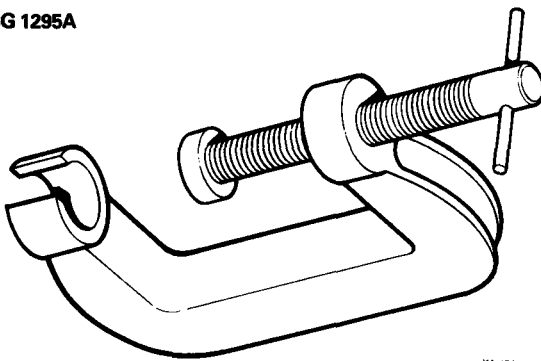
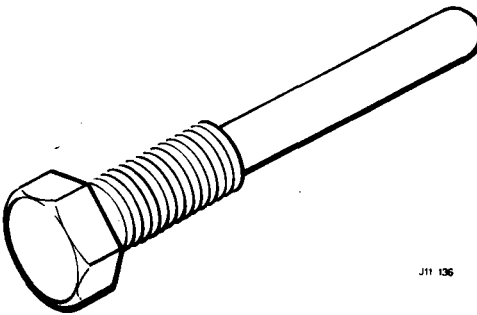
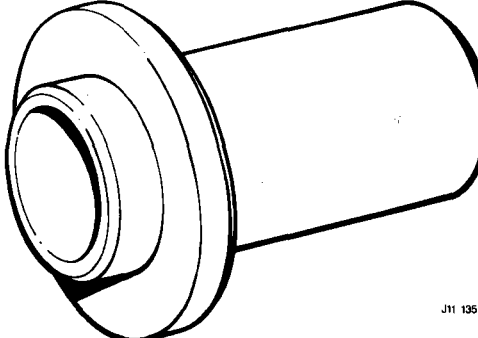
<p><b>18G 677-2</b></p>  <p>J11 167</p> <p>Adaptor set</p>	<p><b>18G 677ZC</b></p>  <p>J11 032</p> <p>Pressure test equipment</p>
<p><b>18G 1004</b></p>  <p>J11 137</p> <p>Circlip pliers</p>	<p><b>18G 1004J</b></p>  <p>J11 139</p> <p>Points for 18G.1004</p>
<p><b>18G 1016 (JD 107)</b></p>  <p>J11 123</p> <p>Clutch spring compressor</p>	<p><b>18G 1295A</b></p>  <p>J11 134</p> <p>Compressor piston accumulator control valve</p>
<p><b>18G 1296A</b></p>  <p>J11 136</p> <p>Extractor bolt oil pump</p>	<p><b>18G 1297</b></p>  <p>J11 135</p> <p>Replacer oil pump and rear extractor oil seals</p>

**AUTOMATIC TRANSMISSION – GM 400 – SECTION 44GM Continued**

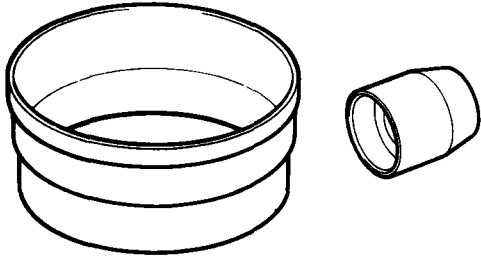
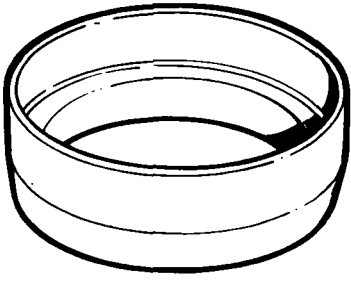
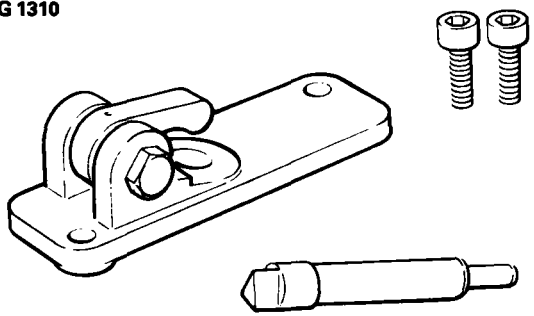
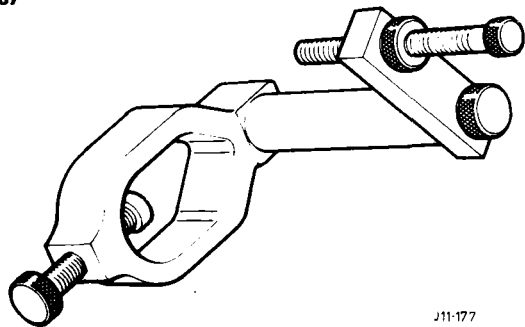
<p><b>18G 1298</b></p>  <p style="text-align: right;">J11 131</p> <p>Forward and intermediate clutch piston replacer seal protector inner</p>	<p><b>18G 1309</b></p>  <p style="text-align: right;">J11 130</p> <p>Intermediate clutch inner seal protection sleeve</p>
<p><b>18G 1310</b></p>  <p style="text-align: right;">J11 129</p> <p>Band application pin selection gauge</p>	<p><b>CBW 87</b></p>  <p style="text-align: right;">J11-177</p> <p>End float checking gauge</p>

**DRIVE SHAFT AND PROPELLER SHAFTS – SECTION 47**

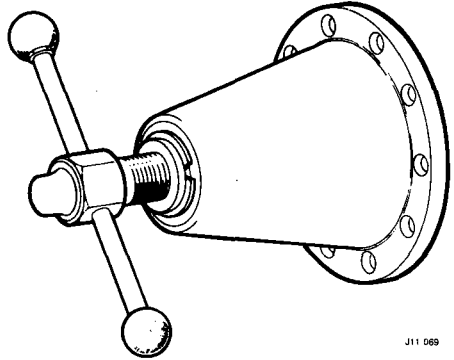
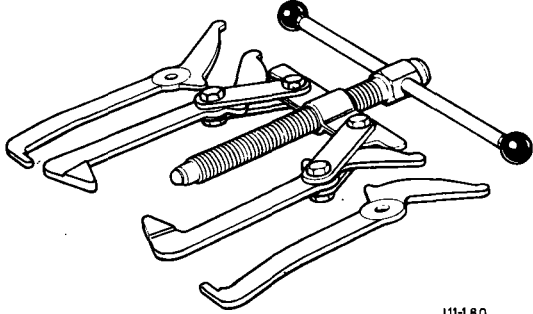
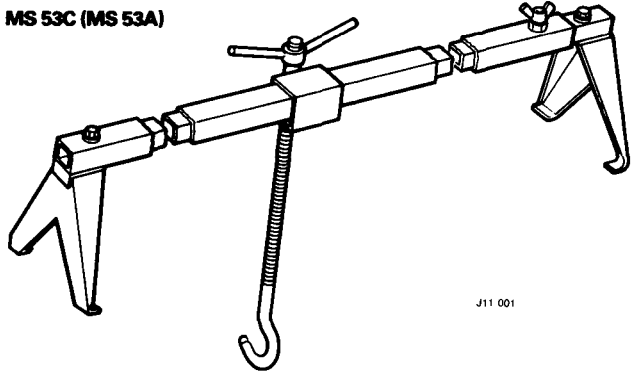
<p><b>JD 1D</b></p>  <p style="text-align: right;">J11 069</p> <p>Hub remover</p>	<p><b>18G 2</b></p>  <p style="text-align: right;">J11-1 80</p> <p>Two legged puller</p>
<p><b>MS 53C (MS 53A)</b></p>  <p style="text-align: right;">J11 001</p> <p>Engine support bracket</p>	

FINAL DRIVE – SECTION 51

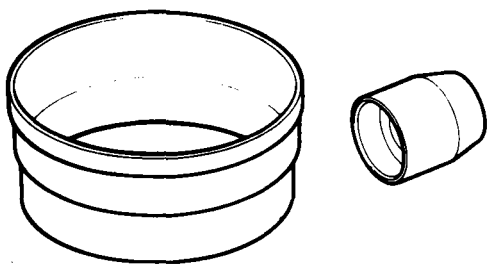
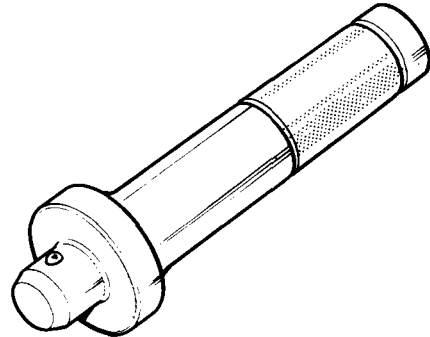
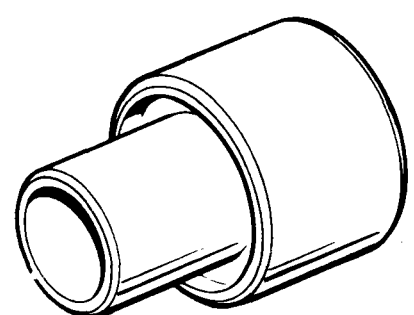
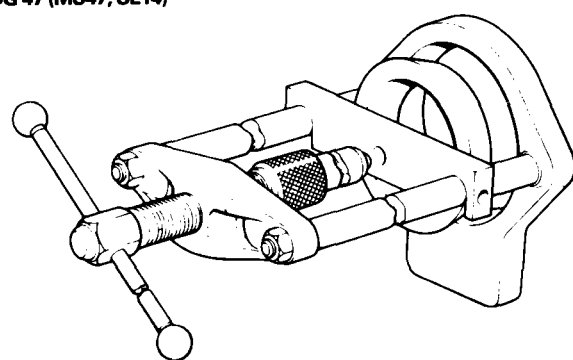
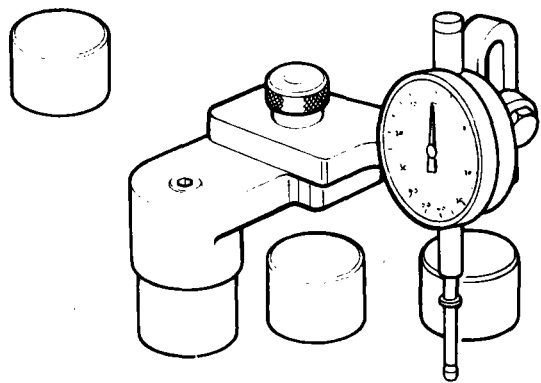
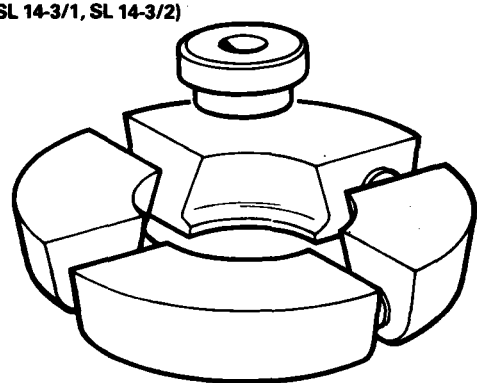
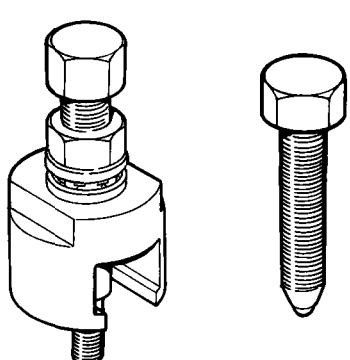
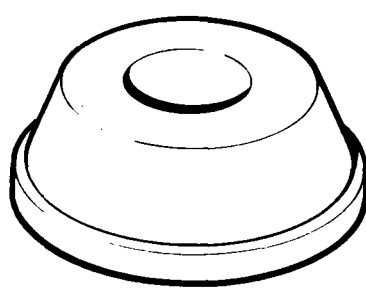
<p><b>18G 120 5</b></p>  <p>J11 131</p> <p>Flange holder</p>	<p><b>18G 134 (MS550, SL550)</b></p>  <p>J11 023</p> <p>Driver handle</p>
<p><b>SL 550-1</b></p>  <p>Replacer differential bearing cone</p>	<p><b>18G 47 (MS47, SL14)</b></p>  <p>Hand press</p>
<p><b>SL3</b></p>  <p>J11 144</p>	<p><b>SL 14-3 (SL 14-3/1, SL 14-3/2)</b></p>  <p>J11 145</p> <p>Adaptor/remover differential bearing cone</p>
<p><b>SL 4HA</b></p>  <p>J11-182</p> <p>Pinion height setting button</p>	<p><b>SL 550-9</b></p>  <p>J11 150</p> <p>Adaptor/replacer – drive pinion inner bearing cup</p>

**FINAL DRIVE – SECTION 51 Continued**

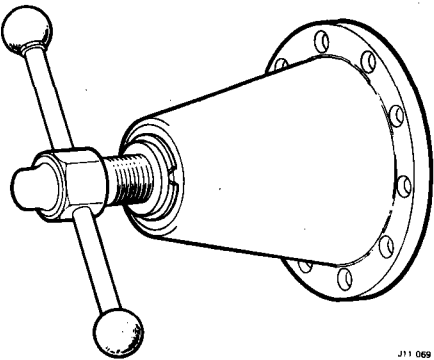
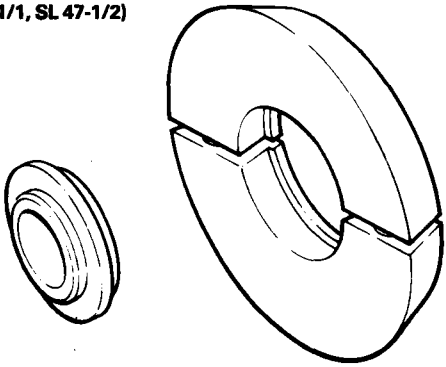
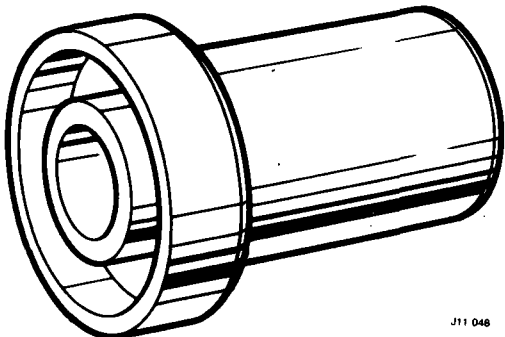
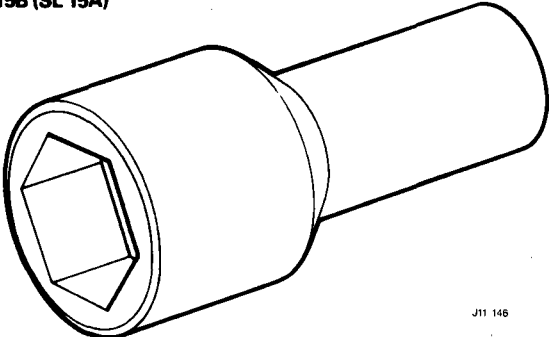
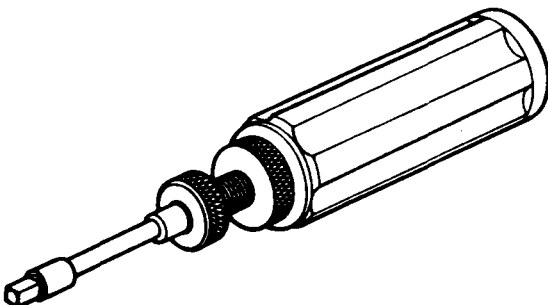
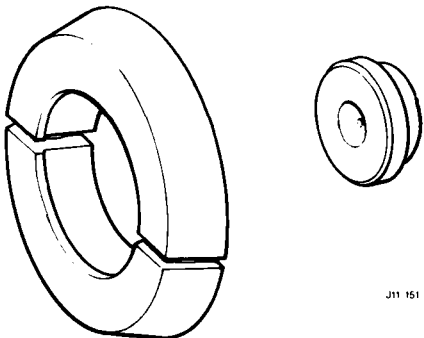
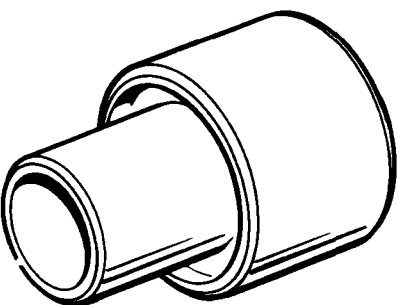
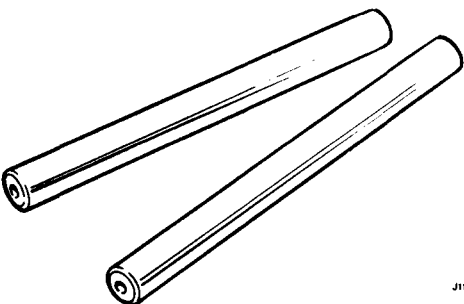
<p><b>SL 550-8</b></p>  <p style="text-align: right;">J11 069</p> <p style="text-align: center;">Adaptor/replacer – drive pinion outer bearing cup</p>	<p><b>SL 47-1 (SL 47-1/1, SL 47-1/2)</b></p>  <p style="text-align: right;">J11 147</p> <p style="text-align: center;">Pinion bearing cone remover/adaptor</p>
<p><b>18G 1428A</b></p>  <p style="text-align: right;">J11 048</p> <p style="text-align: center;">Rear oil seal replacer</p>	<p><b>SL 15B (SL 15A)</b></p>  <p style="text-align: right;">J11 146</p> <p style="text-align: center;">Remover/replacer drive shaft bearing cone</p>
<p><b>18G 681 (CBW 548)</b></p>  <p style="text-align: right;">J11 128</p> <p style="text-align: center;">Torque driver</p>	<p><b>SL 47-3, (SL 47-3/1)</b></p>  <p style="text-align: right;">J11 151</p> <p style="text-align: center;">Output shaft outer bearing remover/replacer</p>
<p><b>SL 47-3/2</b></p>  <p style="text-align: right;">J11 148</p> <p style="text-align: center;">Output shaft outer bearing replacer</p>	<p><b>JD 14</b></p>  <p style="text-align: right;">J11 116</p> <p style="text-align: center;">Dummy shaft</p>

**STEERING – SECTION 57**

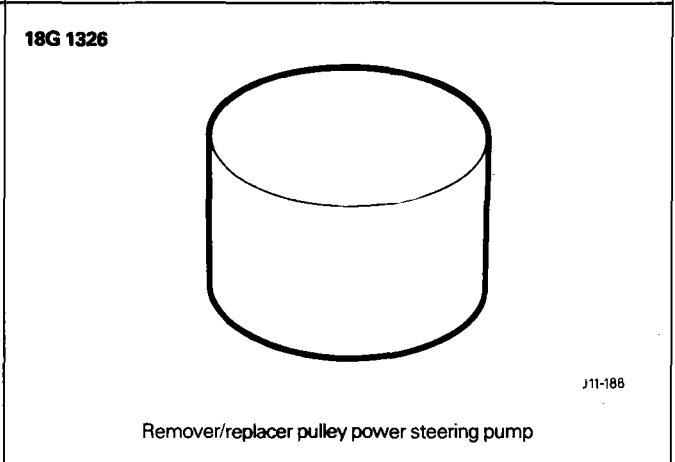
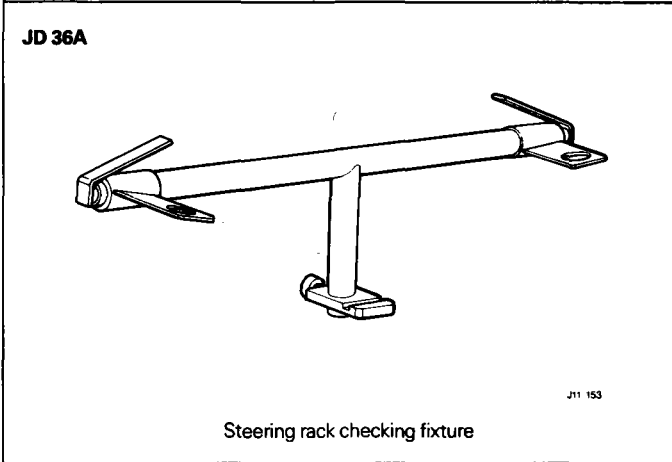
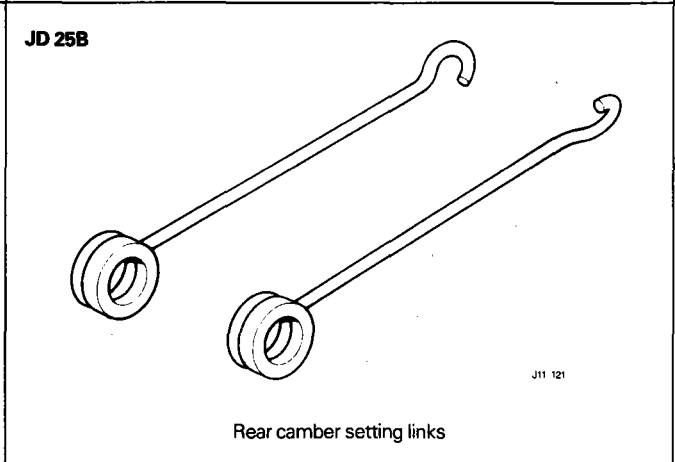
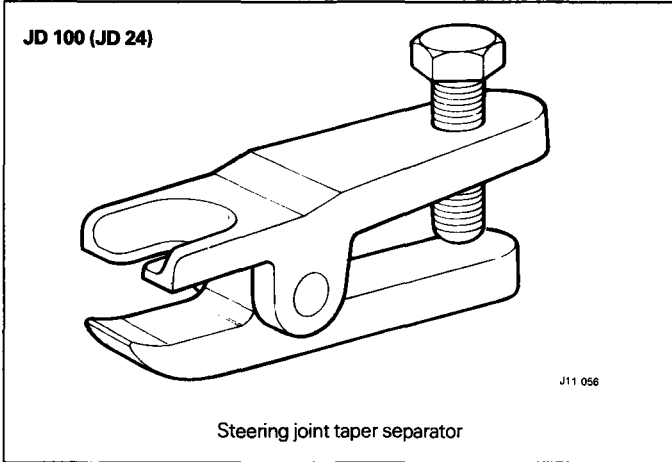
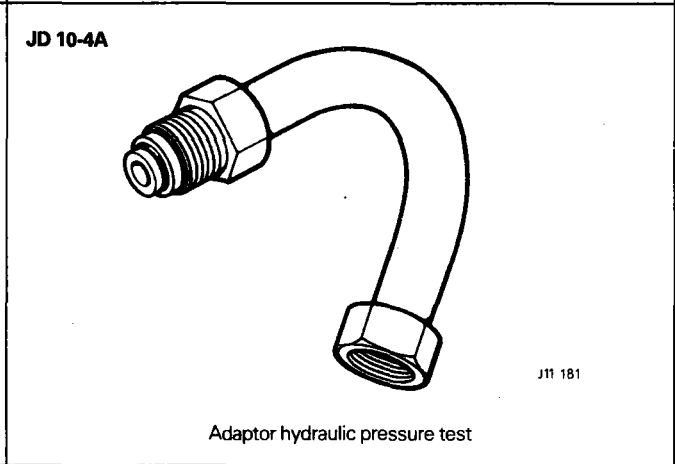
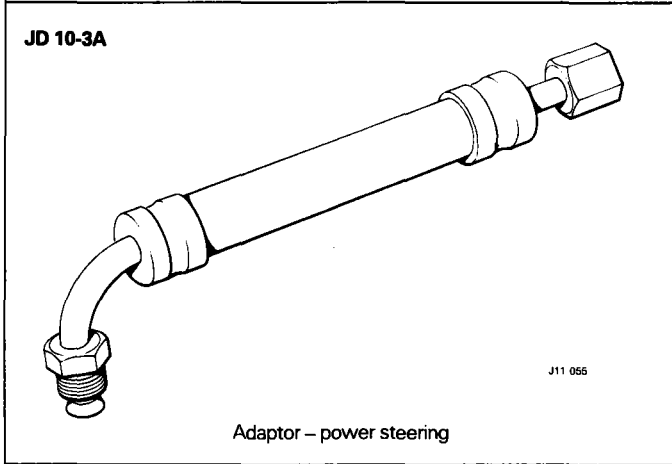
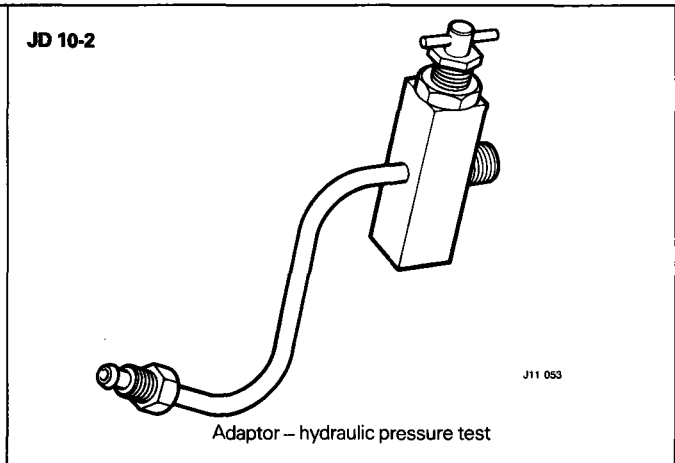
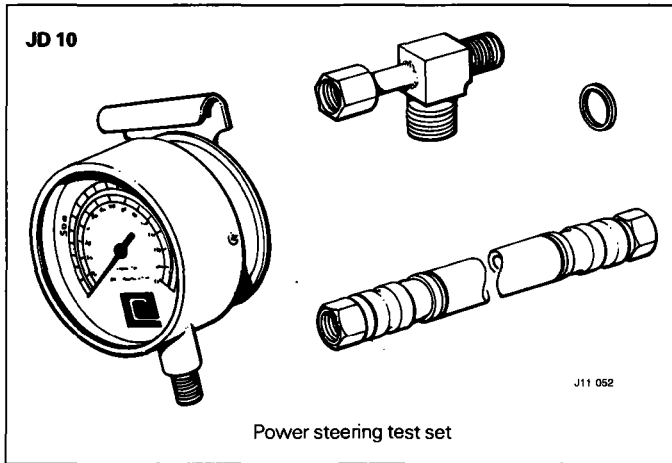

STEERING - SECTION 57 Continued

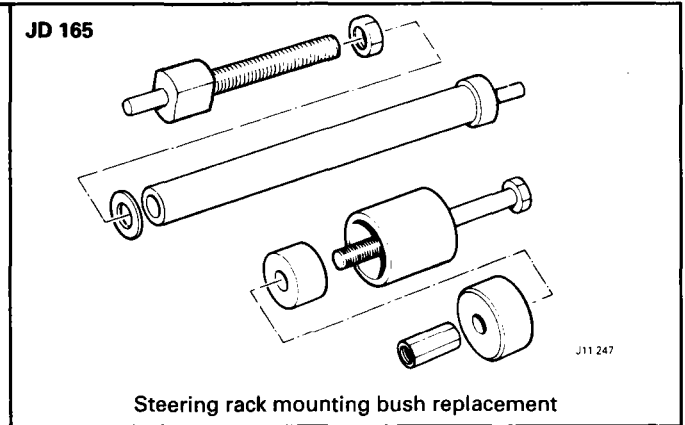
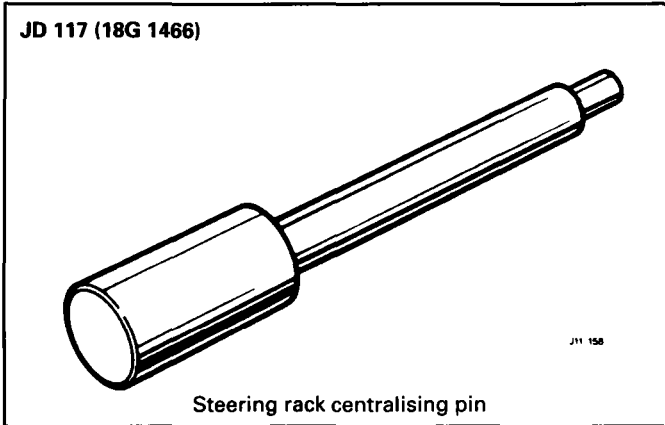

FRONT SUSPENSION - SECTION 60

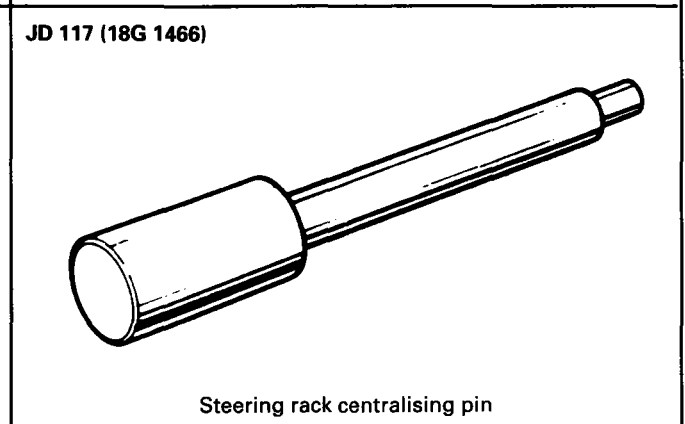
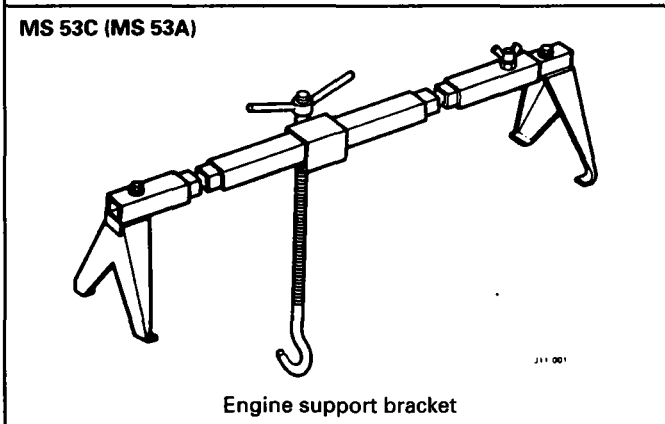
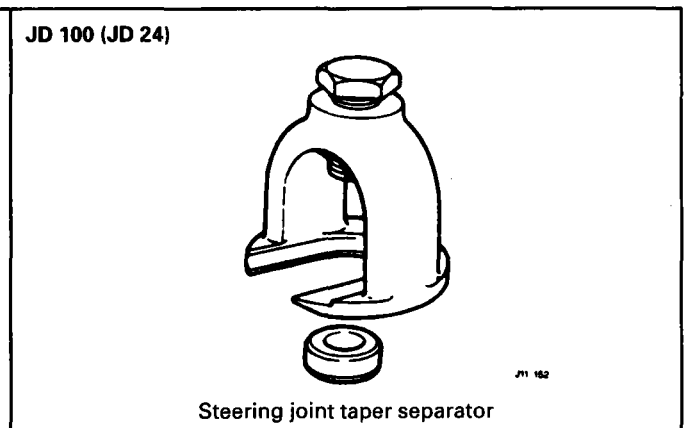
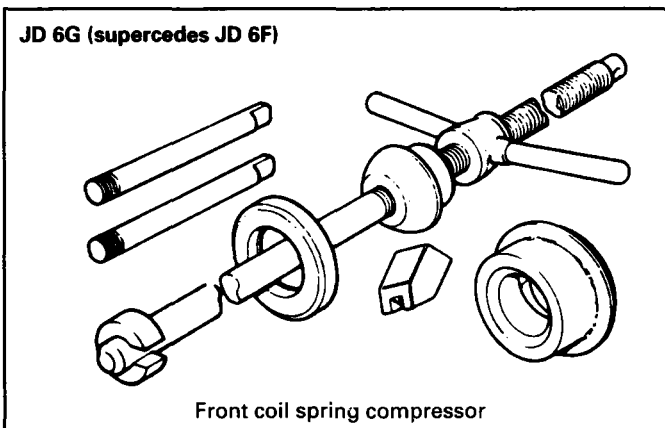

REAR SUSPENSION - SECTION 64

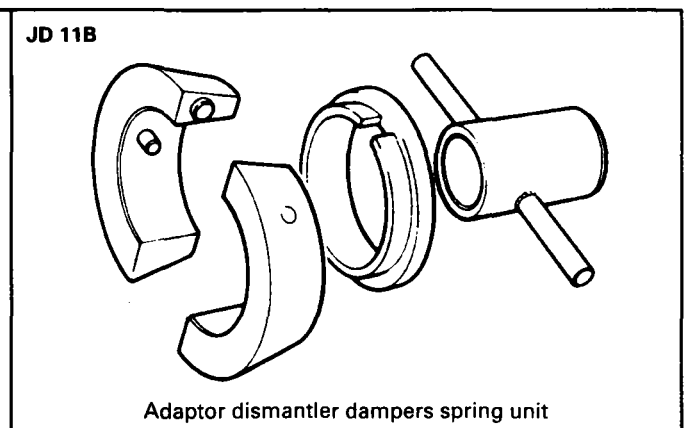
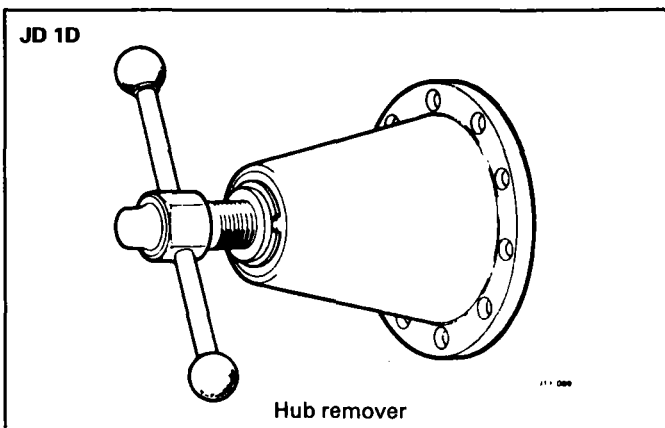



**REAR SUSPENSION – SECTION 64 Continued**

**JD 13B (JD 13A)**

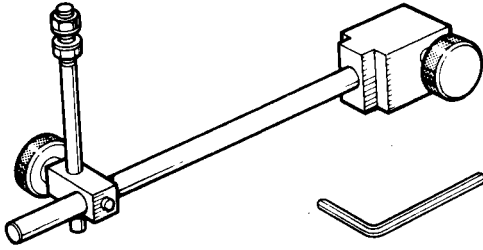

J11 119

Rear hub end-float gauge

**JD 14**

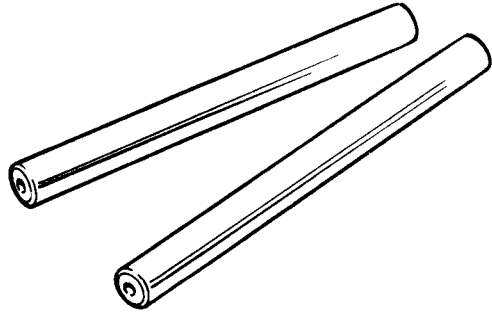

J11 118

Rear wishbone pivot dummy shaft

**JD 15**

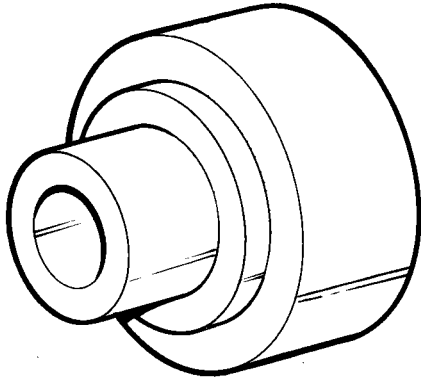

J11 070

Replacer – rear hub master spacer and bearing

**JD 16C**

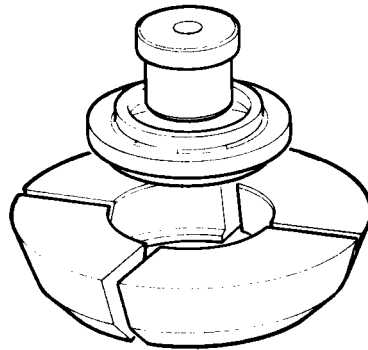

J11 117

Remover/replacer – rear hub outer bearing cone

**JD 20A**

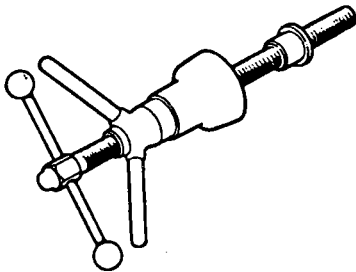

J11 161

Bearing remover – main tool

**JD 20A-1A (JD 20A-1)**

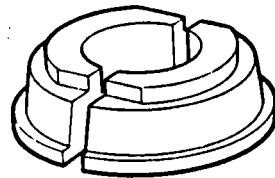

J11 162

Rear hub inner and outer cups remover/replacer adaptor

**JD 21**

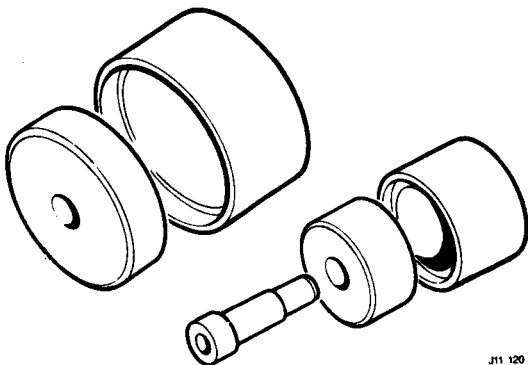

J11 120

Torque arm bush remover/replacer

**JD 25B**

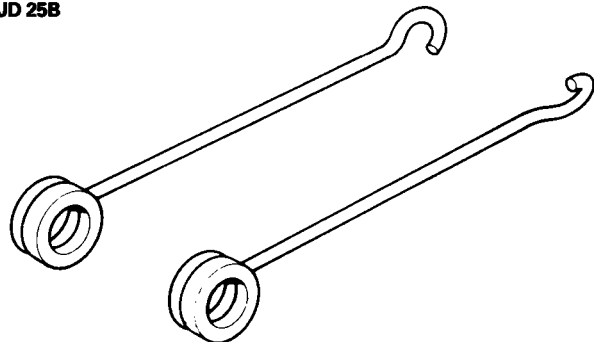

J11 121

Rear camber setting links

REAR SUSPENSION – SECTION 64 Continued

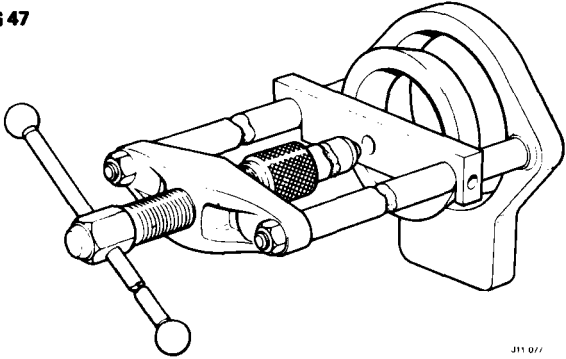
<p>18G 47</p>  <p>Multipurpose handpress</p> <p>J11 077</p>	
--	--

BRAKES – SECTION 70

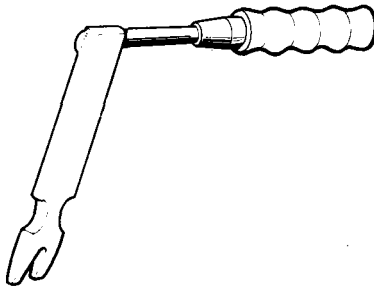
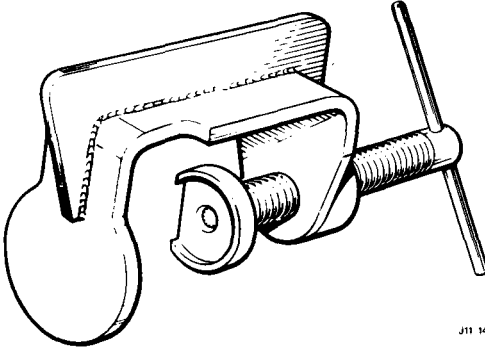
<p>+64932392</p>  <p>Girling brake piston retraction tool</p> <p>J11-189</p>	<p>18G 672</p>  <p>Replacer – disc brake piston seal</p> <p>J11 143</p>
--	--

AIR CONDITIONING – SECTION 82

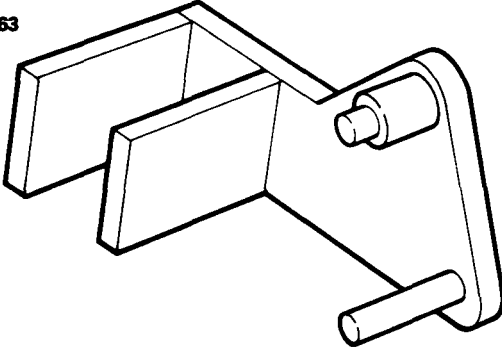
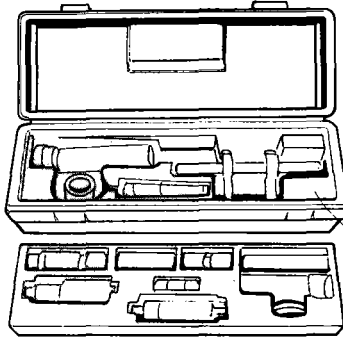
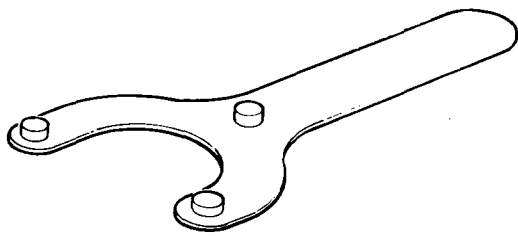
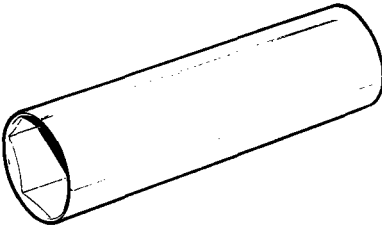
<p>18G 1363</p>  <p>Air conditioning link setting jig</p> <p>J11 140</p>	<p>\$10500</p>  <p>Tool kit</p> <p>J11 186</p>
<p>\$10418</p>  <p>Hub holding tool</p> <p>J11-184</p>	<p>\$10416</p>  <p>Thin walled socket</p> <p>J11-185</p>

## SERVICE TOOLS

### ELECTRICAL – SECTION 86

18G 1364

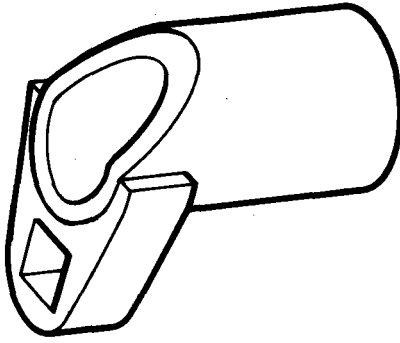

J11170

Spark plug wrench

### INSTRUMENTS – SECTION 88

18G 1001

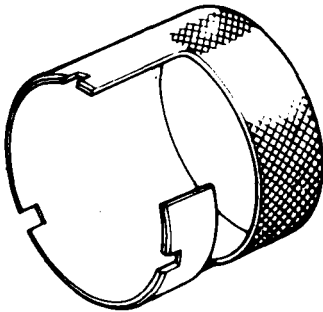

J11 089

Spanner for fuel tank

All service tools listed are available from:

V. L. Churchill & Co. Limited  
P.O. Box 3  
Daventry  
Northamptonshire NN11 4NF

excepting items marked thus:

- \* Available from Jaguar Parts Division
- # Snap-on tool available from a Snap-on tool retail outlet
- + Girling tool available from a Girling tool retail outlet
- \$ Kent Moore tool available from Kent Moore