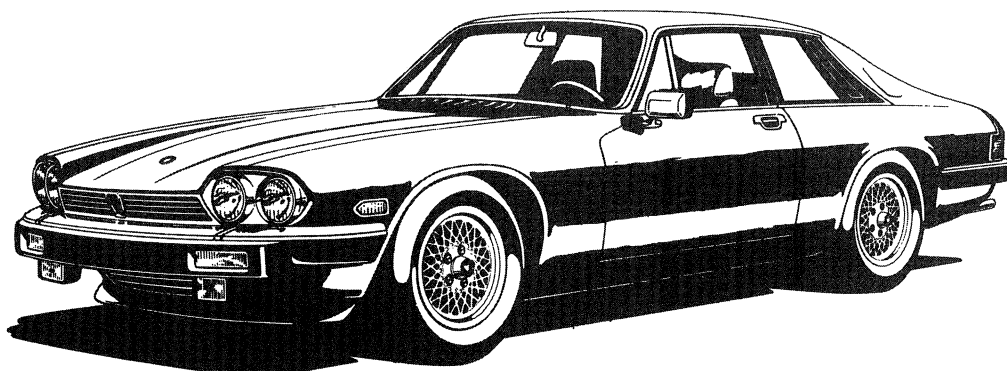
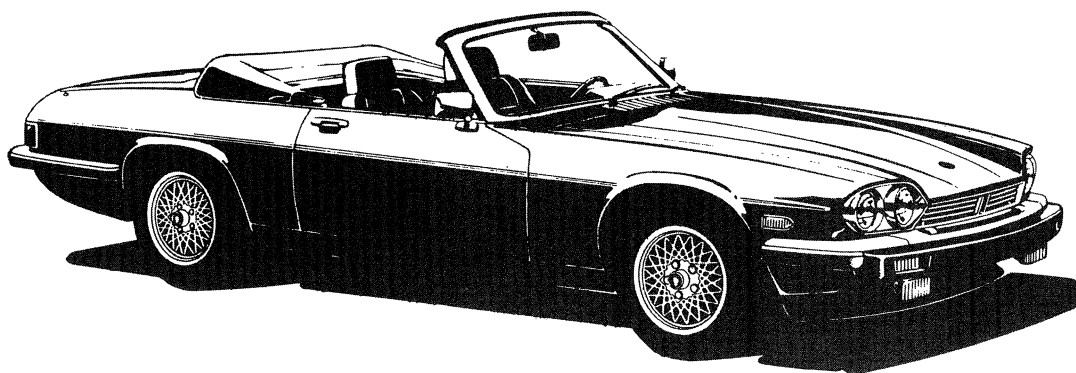


ELECTRICAL GUIDE XJ-S 1989 MY

PUBLICATION S-57/89

XJ-S 1989 MY



PRINTED IN USA
JAGUAR CARS INC.

TABLE OF CONTENTS
XJ-S 1989 MY

DESCRIPTION	WIRING DIAGRAM	COMPONENT LOCATION
HARNESS LAYOUT	—	1.1
CHASSIS GROUND POINTS	—	1.2
BATTERY; STARTER; ALTERNATOR (UP TO VIN 153559)	2.1	2.3
BATTERY; STARTER; ALTERNATOR (VIN 153560-ON)	2.2	2.3
POWER DISTRIBUTION—DIRECT BATTERY FEEDS	3.1	3.2
POWER DISTRIBUTION—IGNITION FEEDS (UP TO VIN 156988)	4.1	4.3
POWER DISTRIBUTION—IGNITION FEEDS (VIN 156989-ON)	4.2	4.3
HEADLIGHTS	5.1	5.2
FOG LIGHTS	6.1	6.2
PARKING LIGHTS; MARKER LIGHTS	7.1	7.2
HAZARD; TURN SIGNALS	8.1	8.2
BRAKE LIGHTS; REVERSE LIGHTS	9.1	9.2
WARNING LIGHTS	10.1	10.2
INTERIOR LIGHTING (COUPE)	11.1	11.3
INTERIOR LIGHTING (CONV.)	11.2	11.3
PANEL LIGHTS	12.1	12.2
TRUNK LIGHTS; TRANS. K/D; CIGAR LIGHTER	13.1	13.2
HEATED REAR WINDOW, MIRRORS	14.1	14.2
WINDSHIELD WIPERS, WASHERS (UP TO VIN 154404)	15.1	15.4
WINDSHIELD WIPERS, WASHERS (VIN 154404 TO 156988)	15.2	15.4
WINDSHIELD WIPERS, WASHERS (VIN 156989-ON)	15.3	15.4
RADIO; ANTENNA	16.1	16.2

TABLE OF CONTENTS
XJ-S 1989 MY

DESCRIPTION	WIRING DIAGRAM	COMPONENT LOCATION
HORNS; COOLING FAN (UP TO VIN 156988)	17.1	17.3
HORNS; COOLING FAN (VIN 156989-ON)	17.2	17.3
INSTRUMENTATION; TRIP COMPUTER	18.1	18.2
CRUISE CONTROL	19.1	19.2
POWER WINDOWS (UP TO VIN 156988)	20.1	20.3
POWER WINDOWS (VIN 156989-ON)	20.2	20.3
MOTORIZED DOOR LOCKS	21.1	21.2
POWER MIRRORS	22.1	22.2
HEATED SEATS; POWER LUMBAR SUPPORTS	23.1	23.2
PASSIVE RESTRAINT SEAT BELTS	24.1	24.2
EFI and EMISSIONS CONTROL (UP TO VIN 153559)	25.1	25.3
EFI and EMISSIONS CONTROL (VIN 153560-ON)	25.2	25.3
CLIMATE CONTROL (COUPE)	26.1	26.3
CLIMATE CONTROL (CONV.)	26.2	26.3
ANTI-LOCK BRAKING	27.1	27.2
CONVERTIBLE TOP (CONV.)	28.1	28.2
DIGITAL IGNITION	29.1	29.2

FORWARD OF FRONT BULKHEAD

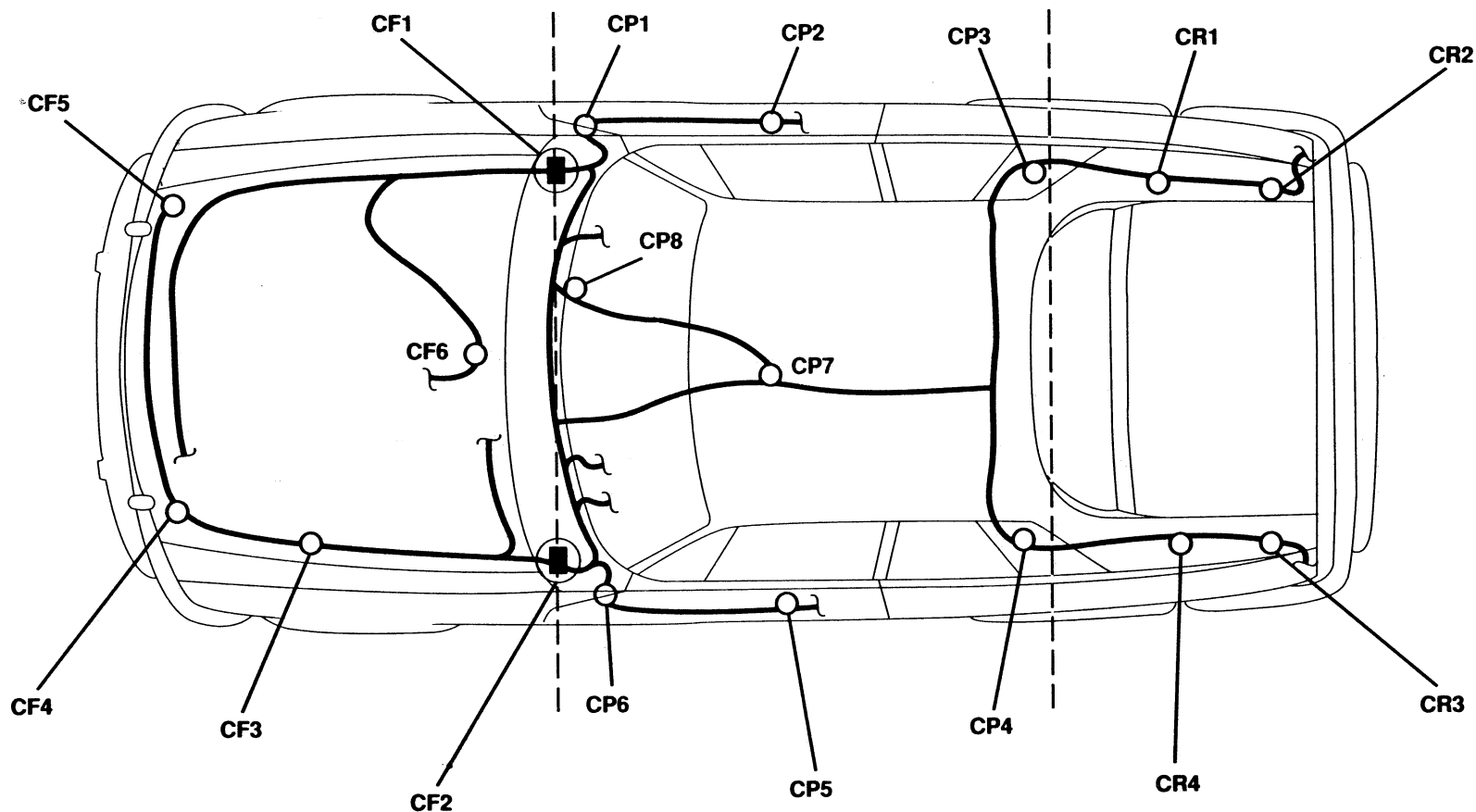
- CF1 RIGHT BULKHEAD
- CF2 LEFT BULKHEAD
- CF3 LEFT FRONT INNER FENDER
- CF4 LEFT FRONT CORNER
- CF5 RIGHT FRONT CORNER
- CF6 ENGINE

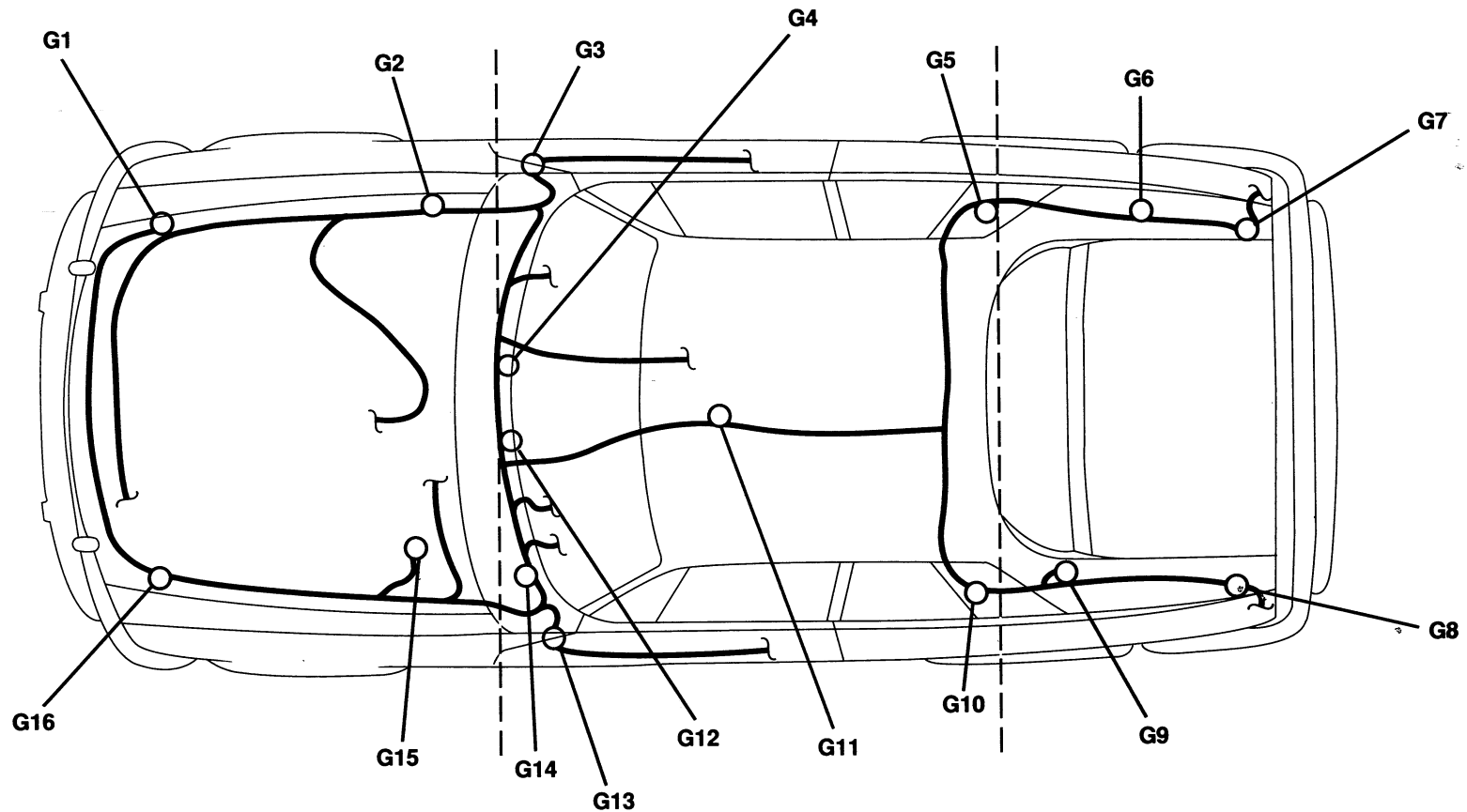
IN PASSENGER AREA

- CP1 RIGHT DOOR POST
- CP2 INSIDE RIGHT DOOR
- CP3 RIGHT REAR, UNDER SEAT
- CP4 LEFT REAR, UNDER SEAT
- CP5 INSIDE LEFT DOOR
- CP6 LEFT DOOR POST
- CP7 CENTER CONSOLE
- CP8 BEHIND CENTER PANEL (RIGHT SIDE)

REAR OF REAR BULKHEAD

- CR1 TRUNK, RIGHT SIDE
- CR2 RIGHT REAR CORNER
- CR3 LEFT REAR CORNER
- CR4 TRUNK, LEFT SIDE





- G1 RIGHT FRONT INNER FENDER
- G2 RELAY CLUSTER
- G3 RIGHT "A" POST
- G4 CENTER SUPPORT RIGHT SIDE (BEHIND A/C)
- G5 RIGHT REAR WHEEL ARCH (UNDER REAR SEAT)
- G6 TRUNK RIGHT SIDE
- G7 RIGHT REAR INNER FENDER
- G8 LEFT REAR INNER FENDER

- G9 REAR WINDOW—LEFT
- G10 LEFT REAR WHEEL ARCH (UNDER REAR SEAT)
- G11 CENTER CONSOLE
- G12 CENTER SUPPORT LEFT SIDE (BEHIND A/C)
- G13 LEFT "A" POST
- G14 FRONT BULKHEAD (BEHIND INST. PANEL)
- G15 FRONT BULKHEAD (ENGINE SIDE)
- G16 LEFT FRONT INNER FENDER

FIG 1.2

CHASSIS GROUND POINTS

XJ-S
1989 MY

FIG 2.1

BATTERY; STARTER; ALTERNATOR (up to VIN 153559)

XJ-S
1989 MY

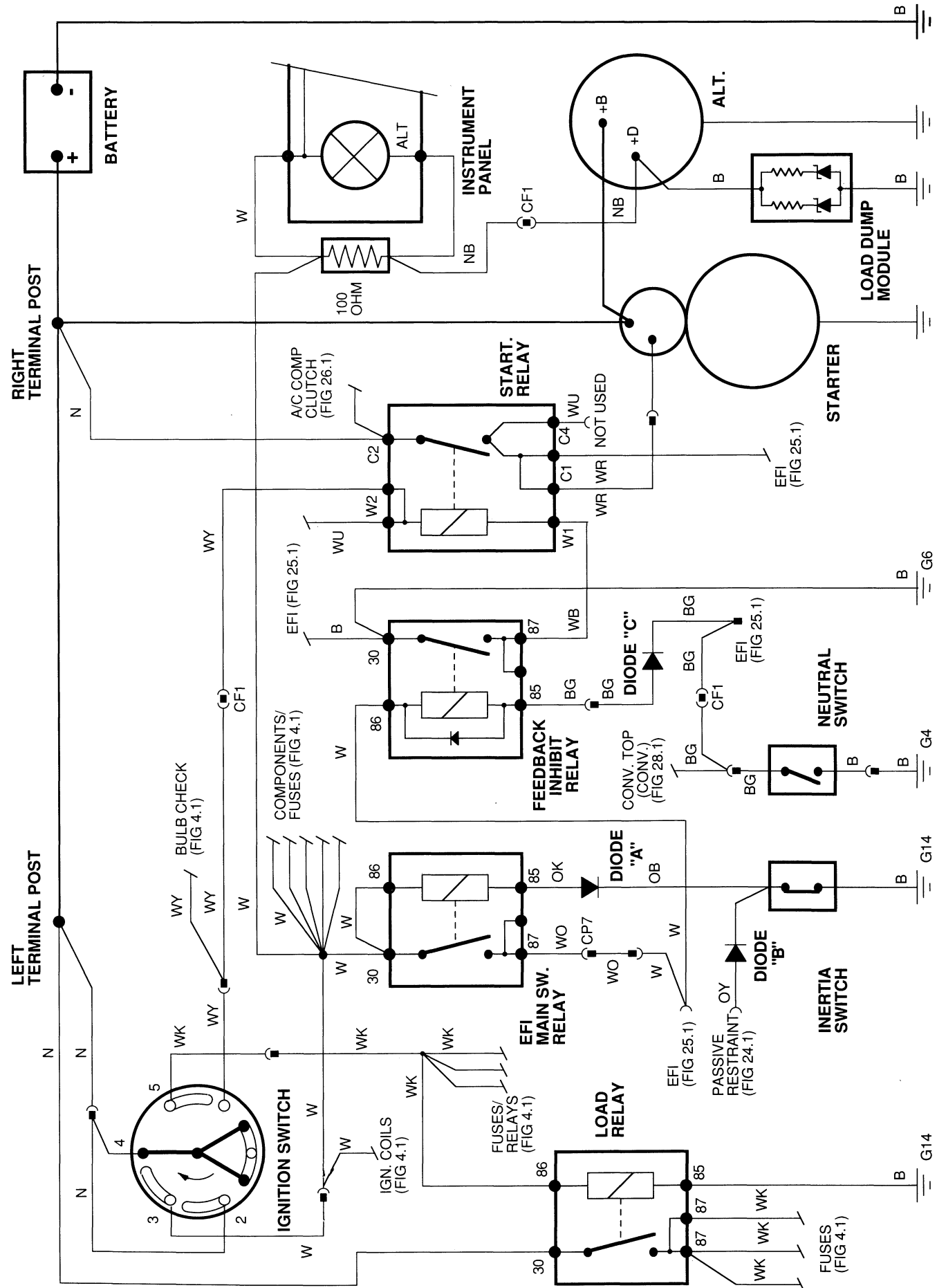
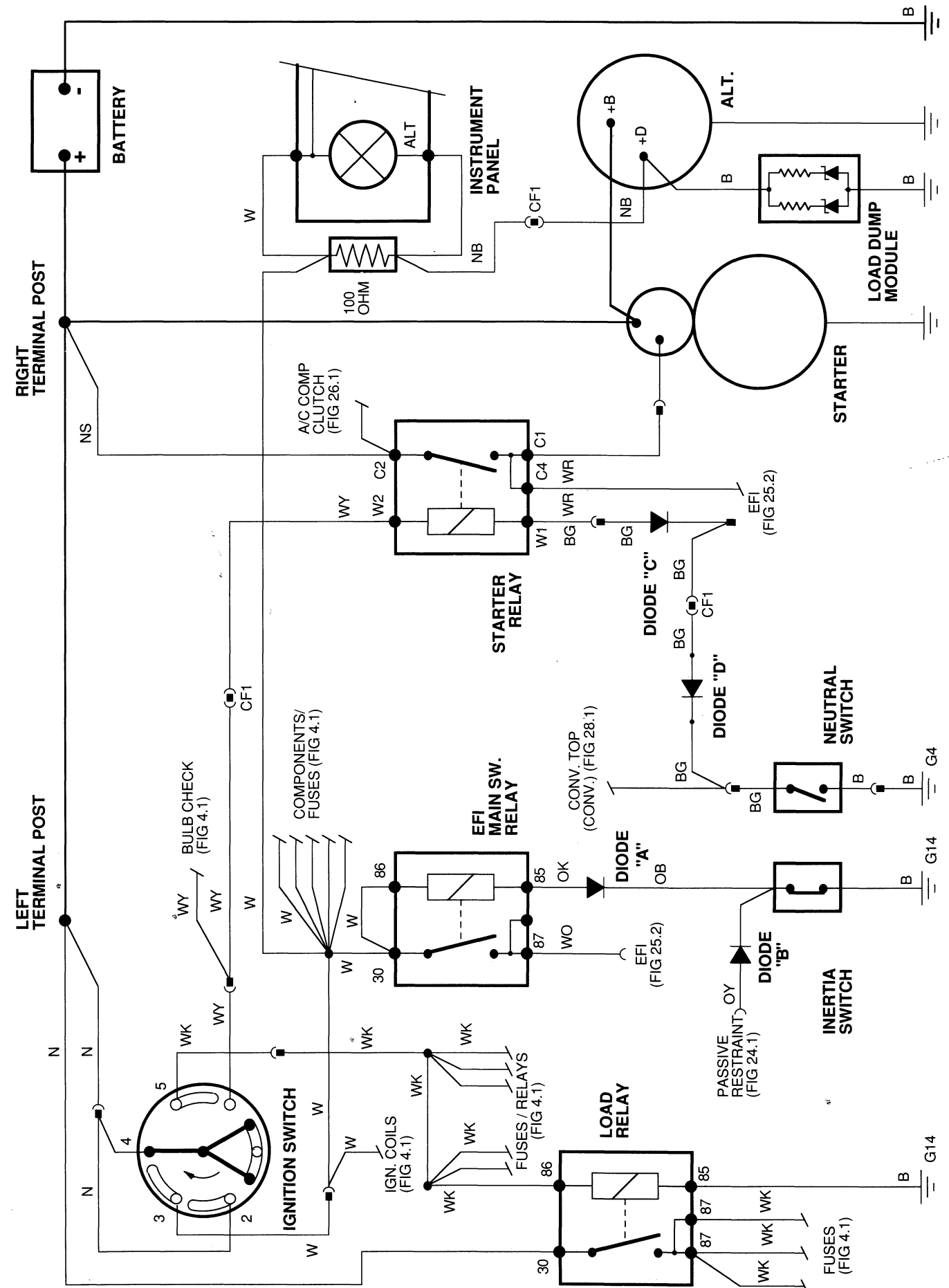


FIG 2.2

BATTERY; STARTER; ALTERNATOR (VIN 153560-ON)

XJ-S
1989 MY



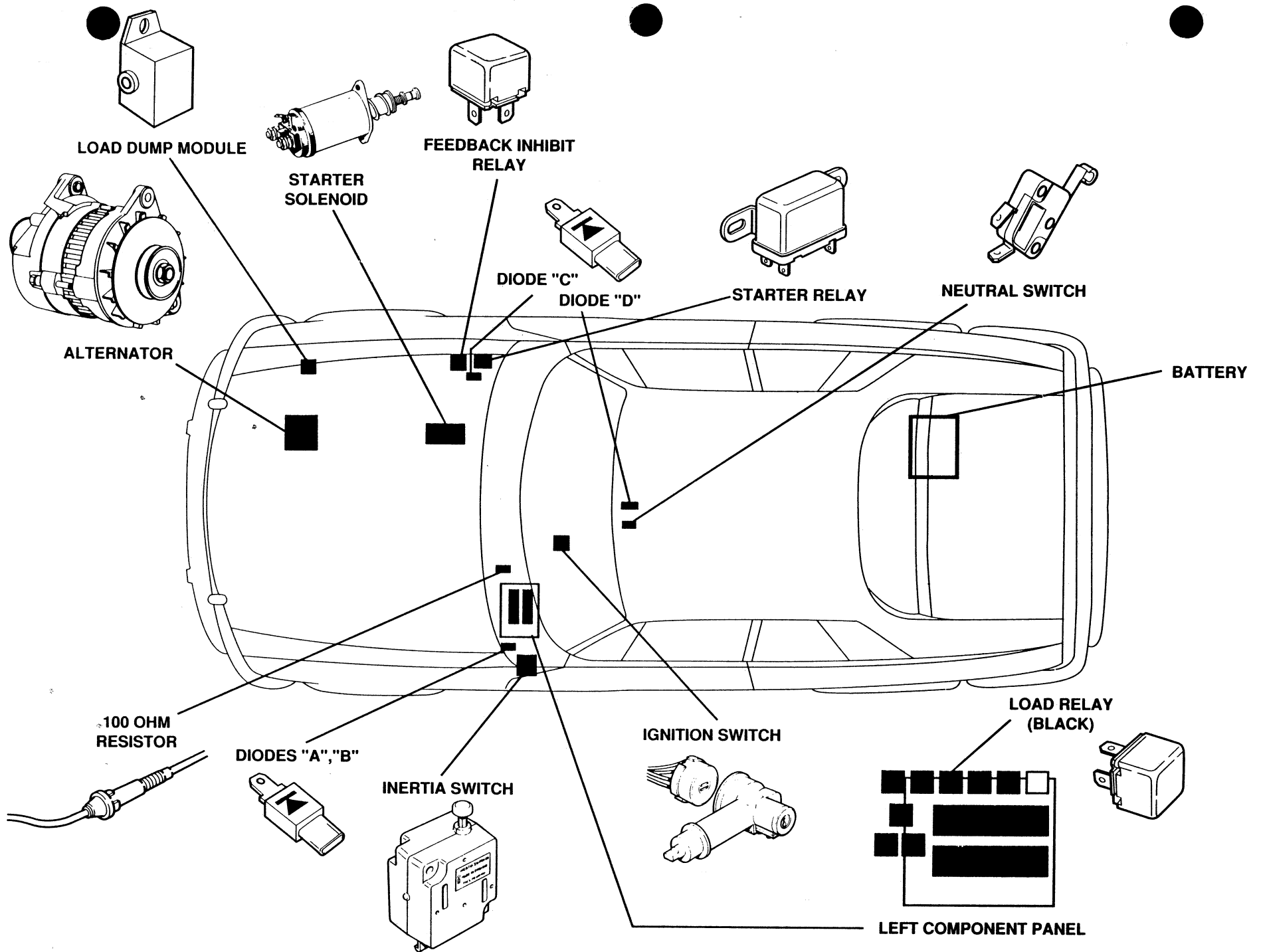


FIG 2.3

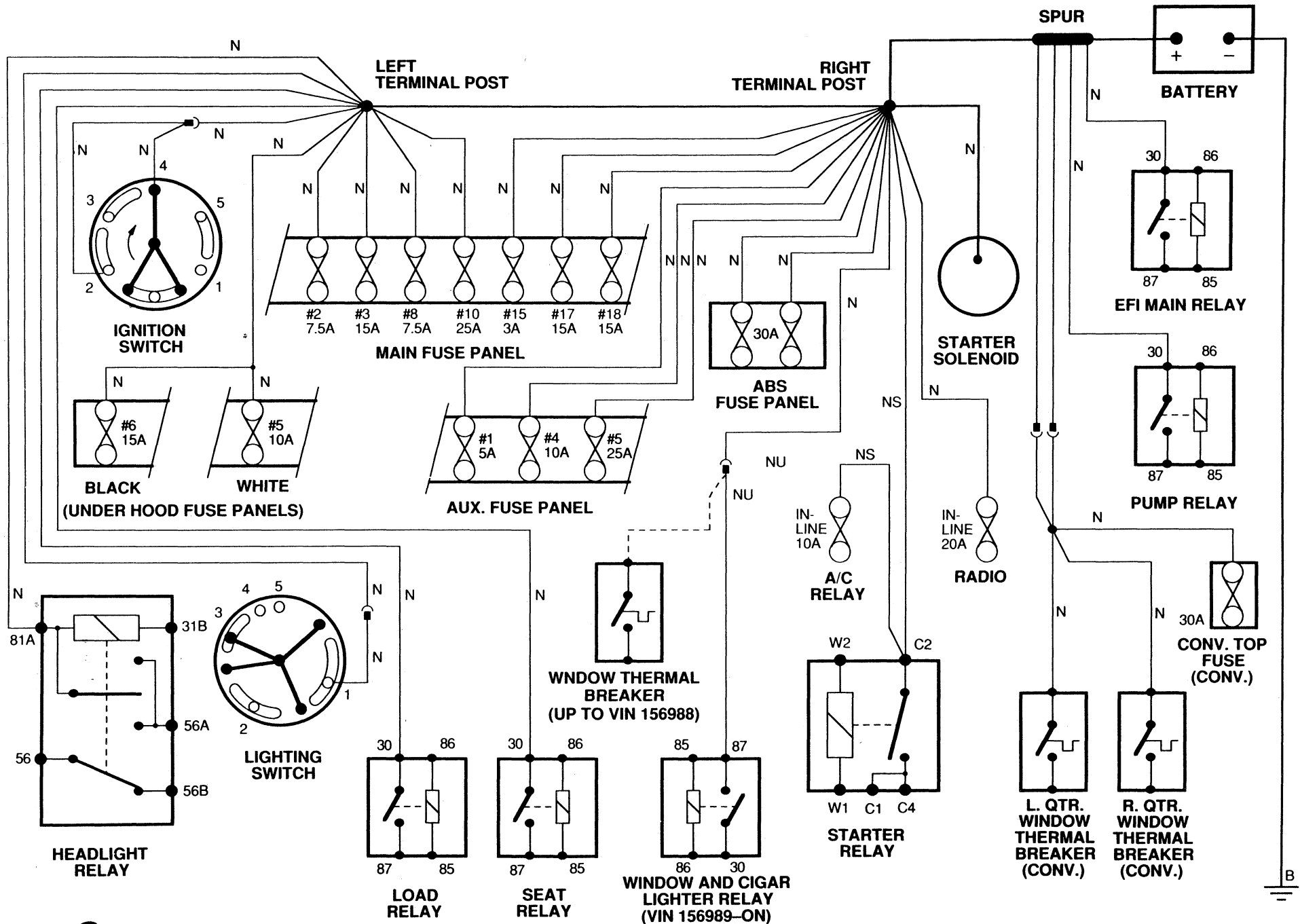
BATTERY; STARTER; ALTERNATOR

XJ-S
1989 MY

FIG 3.1

POWER DISTRIBUTION - DIRECT BATTERY FEEDS

XJ-S
1989 MY



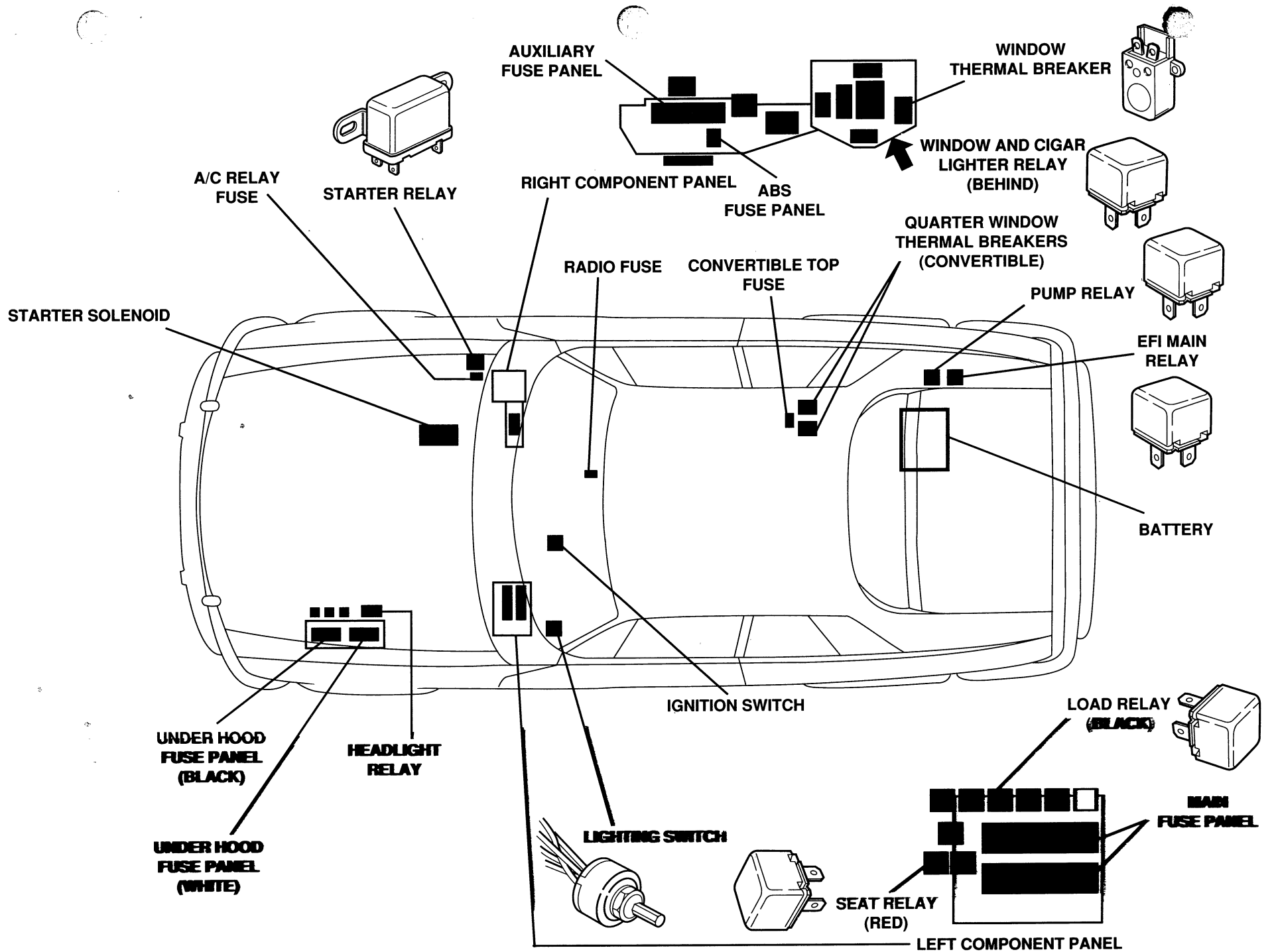


FIG 3.2

POWER DISTRIBUTION — DIRECT BATTERY FEEDS

XJ-S
1989 MY

FIG 4.1

POWER DISTRIBUTION—IGNITION FEEDS
(UP TO VIN 156988)

XJ-S
1989 MY

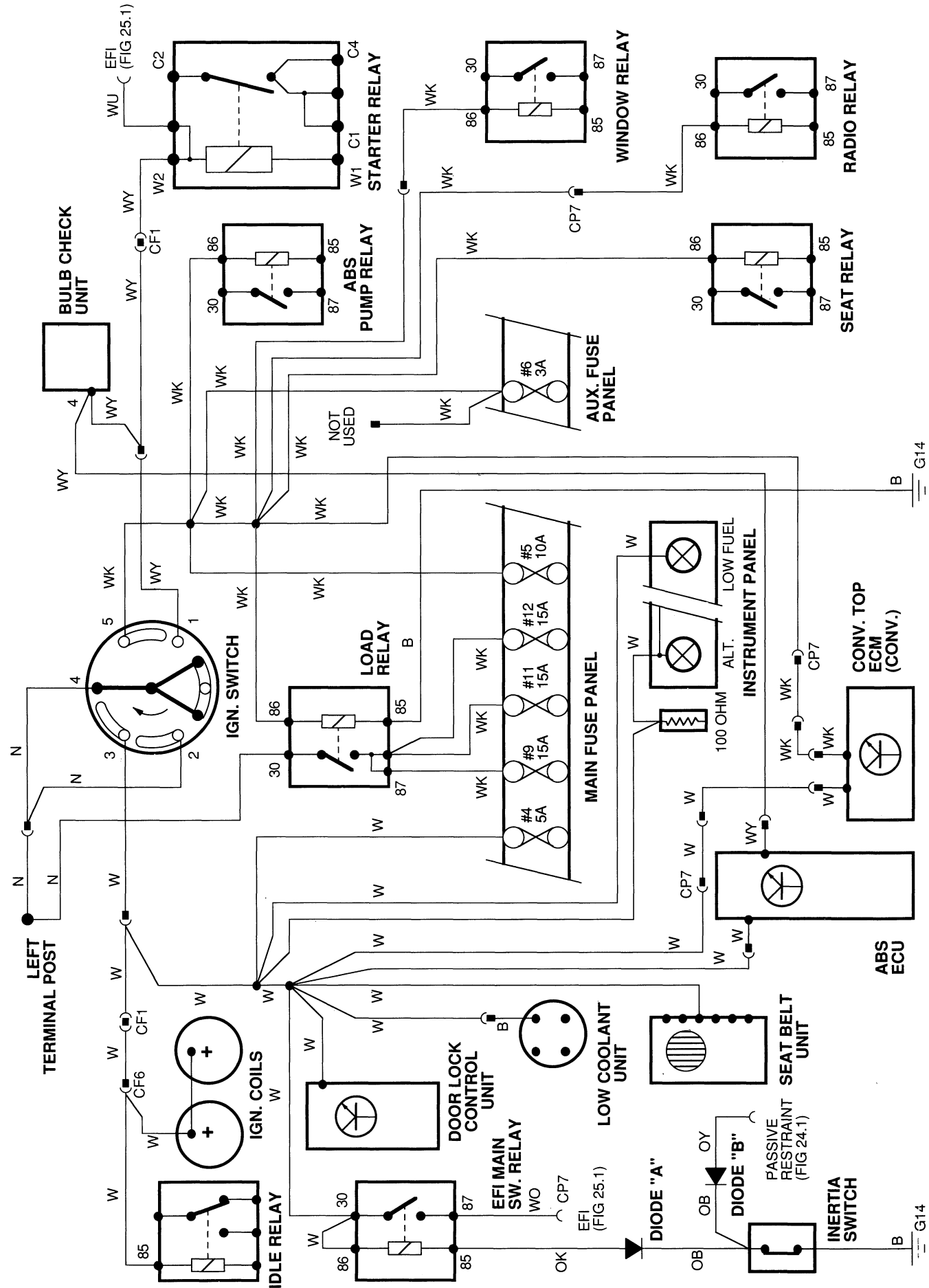
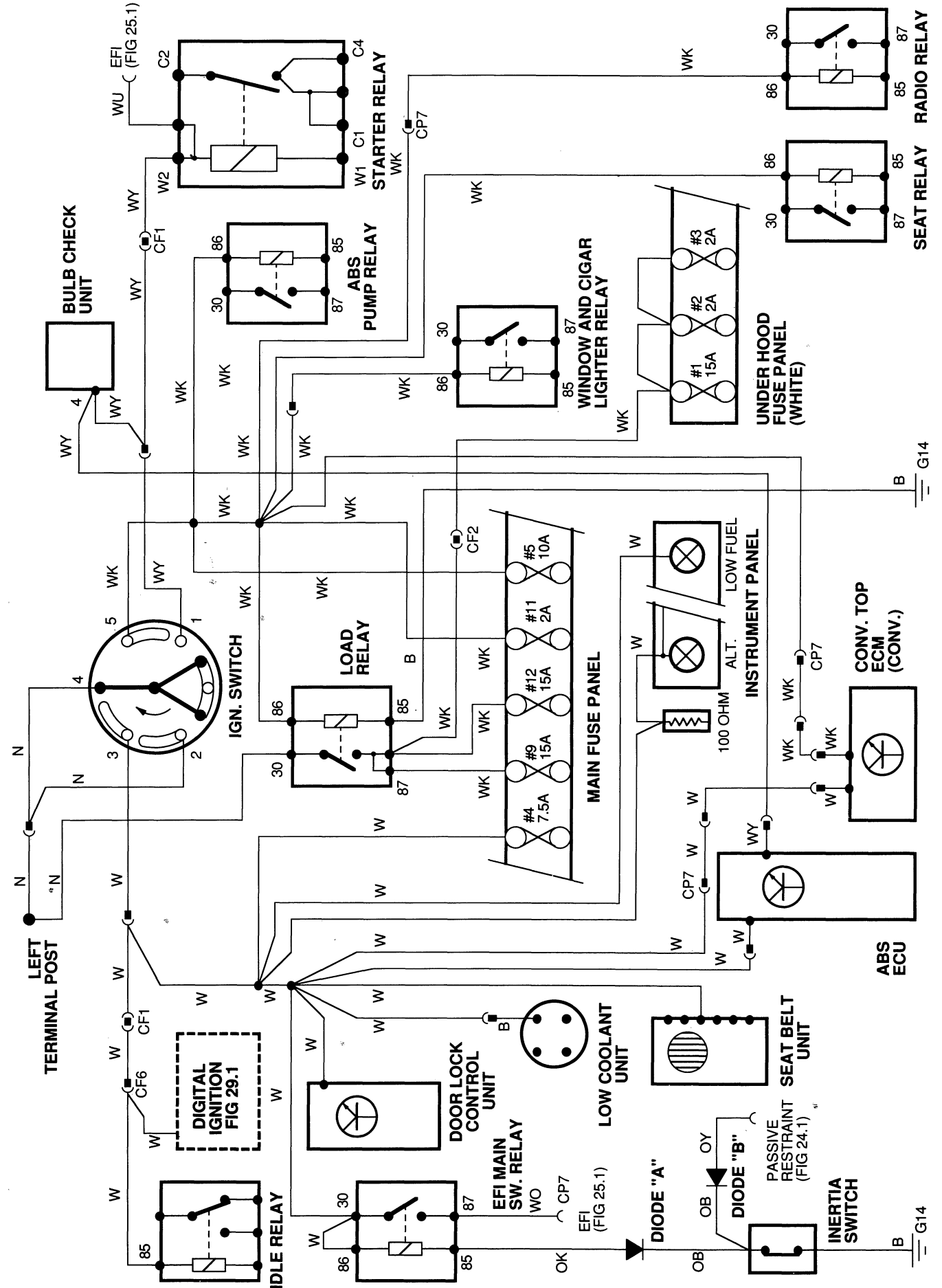


FIG 4.2

POWER DISTRIBUTION—IGNITION FEEDS
(VIN 156989-ON)

XJ-S
1989 MY



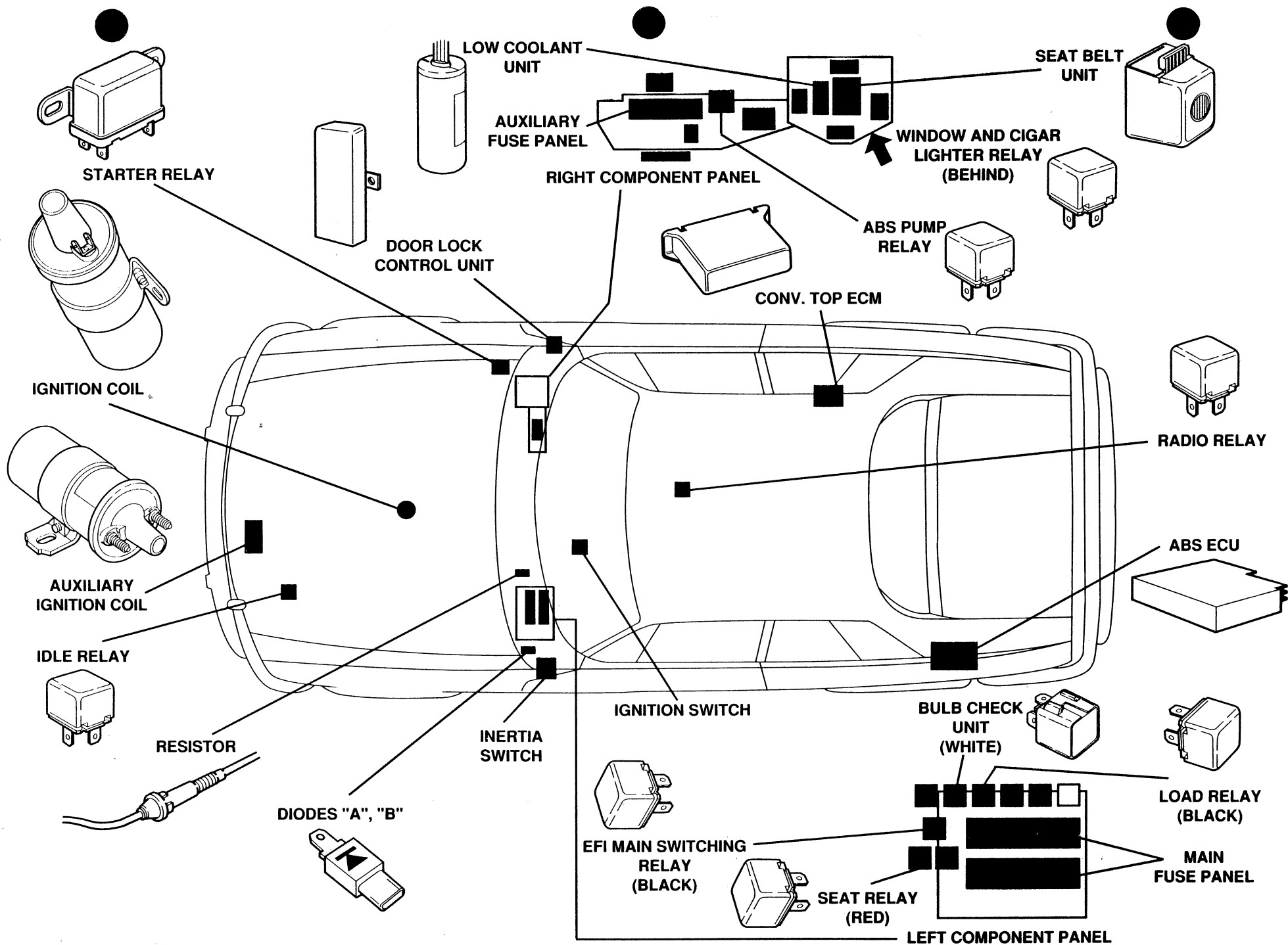


FIG 4.3

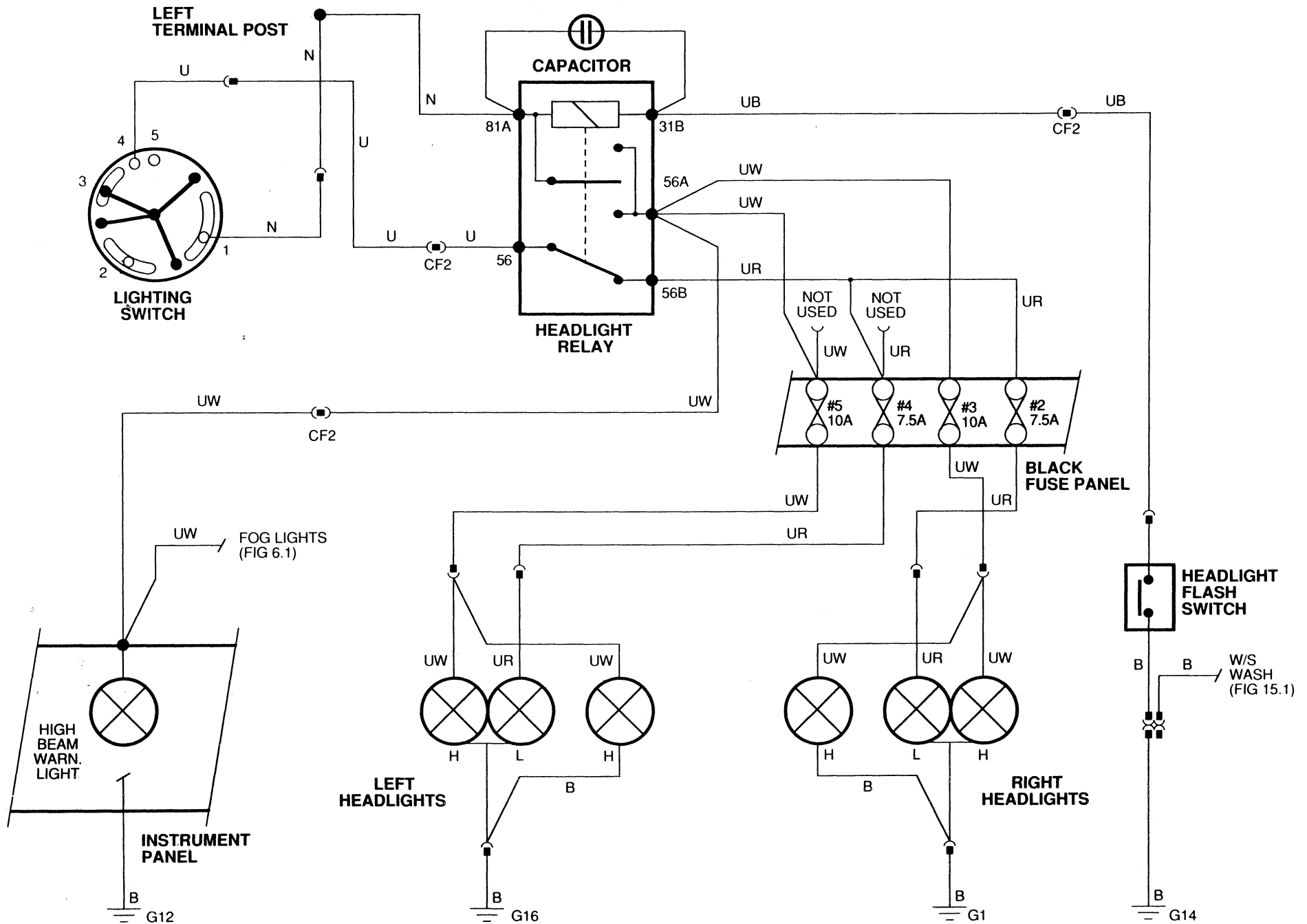
POWER DISTRIBUTION — IGNITION FEEDS

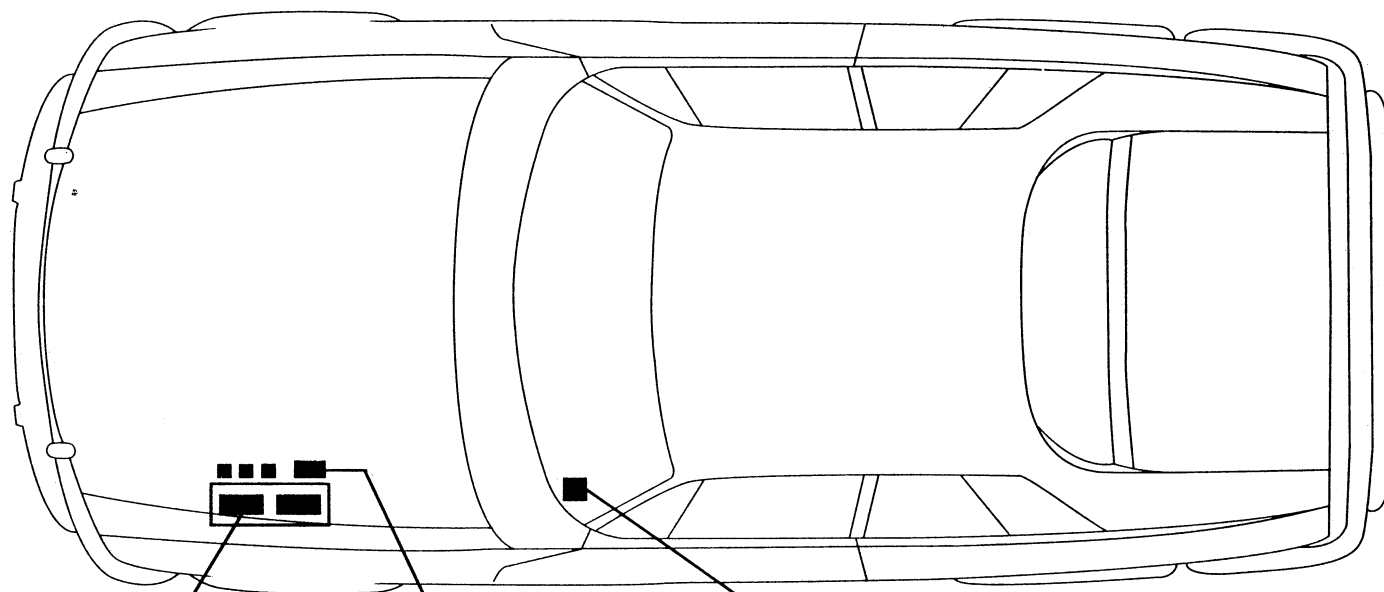
XJ-S
1989 MY

FIG 5.1

HEADLIGHTS

XJ-S
1989 MY





UNDER HOOD
FUSE PANEL
(BLACK)

HEADLIGHT
RELAY

LIGHTING SWITCH

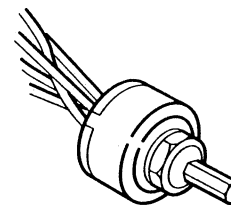
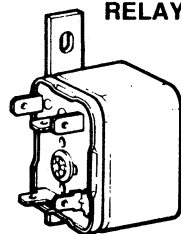
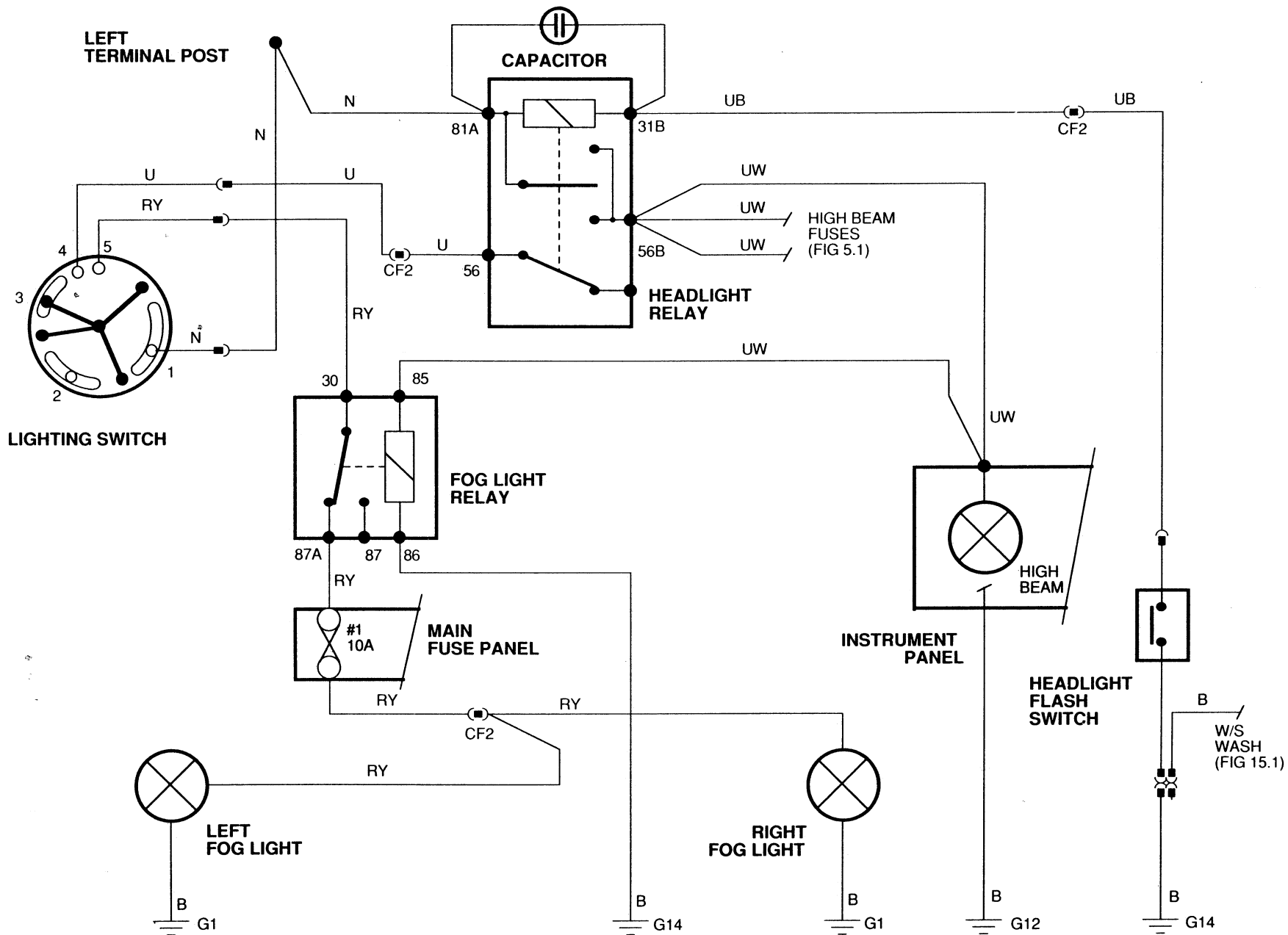


FIG 5.2

HEADLIGHTS

XJ-S
1989 MY



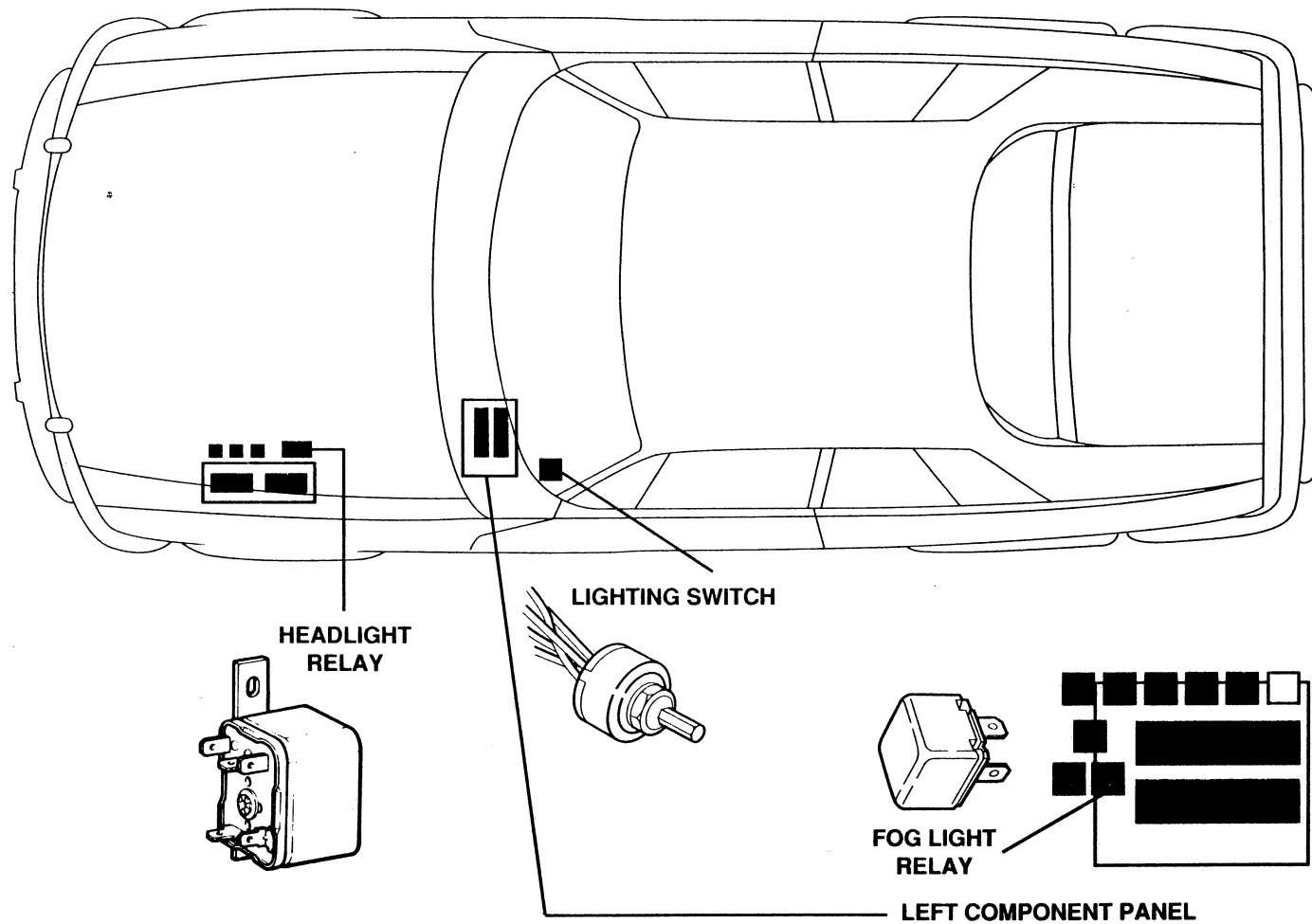
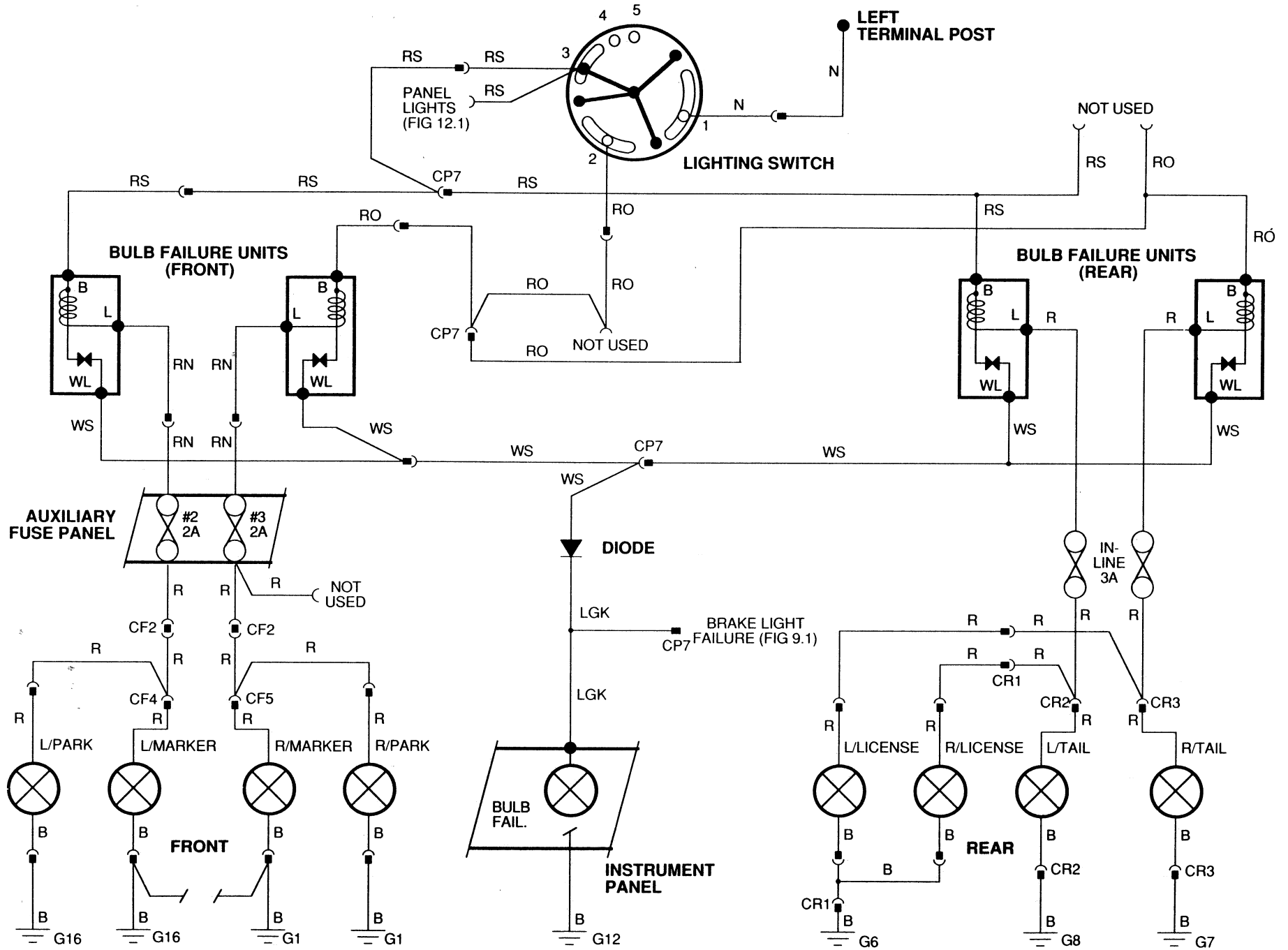


FIG 6.2

FOG LIGHTS

XJ-S
1989 MY



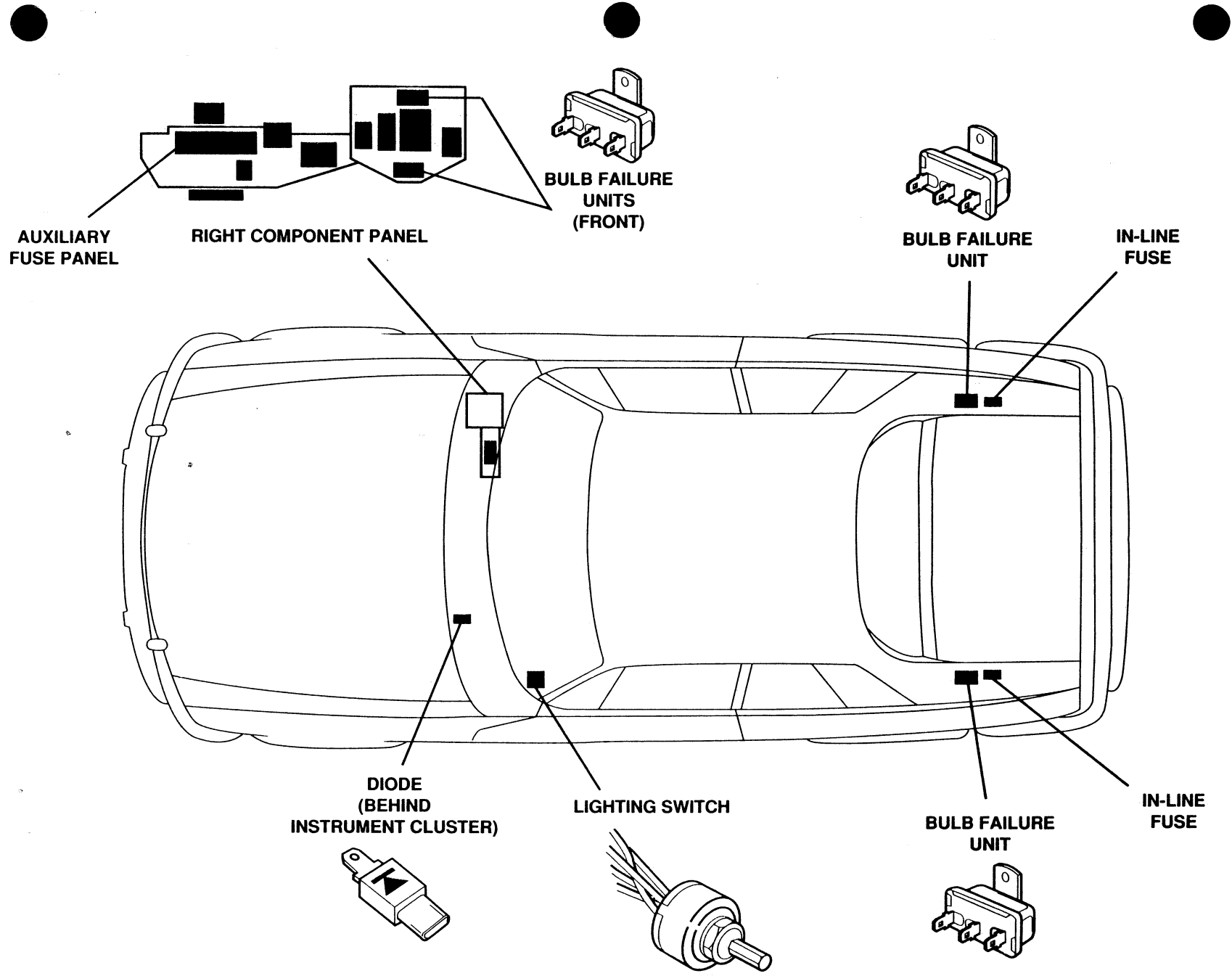


FIG 7.2

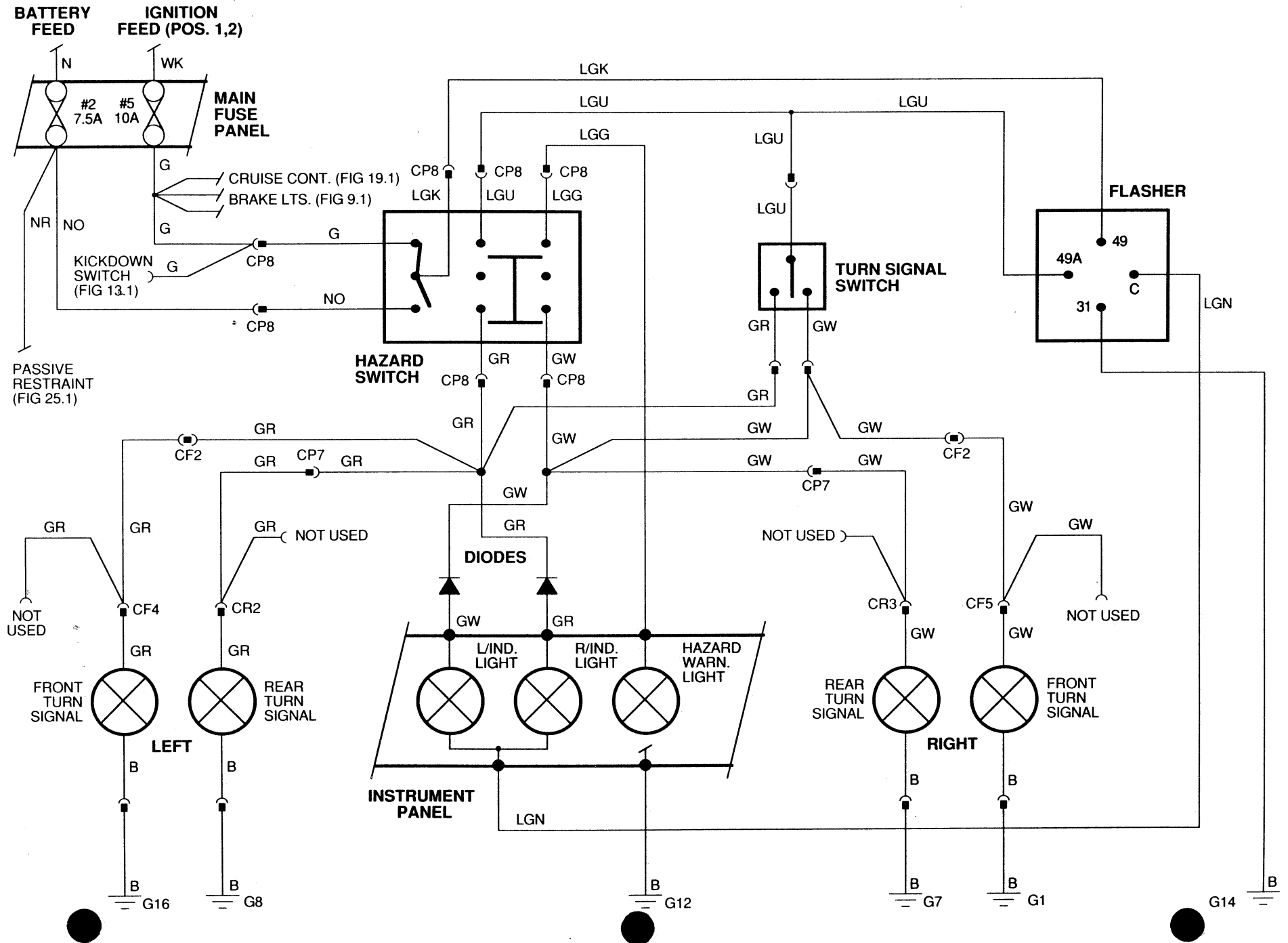
PARKING LIGHTS; MARKER LIGHTS

XJ-S
1989 MY

FIG 8.1

HAZARD; TURN SIGNALS

XJ-S
1989 MY



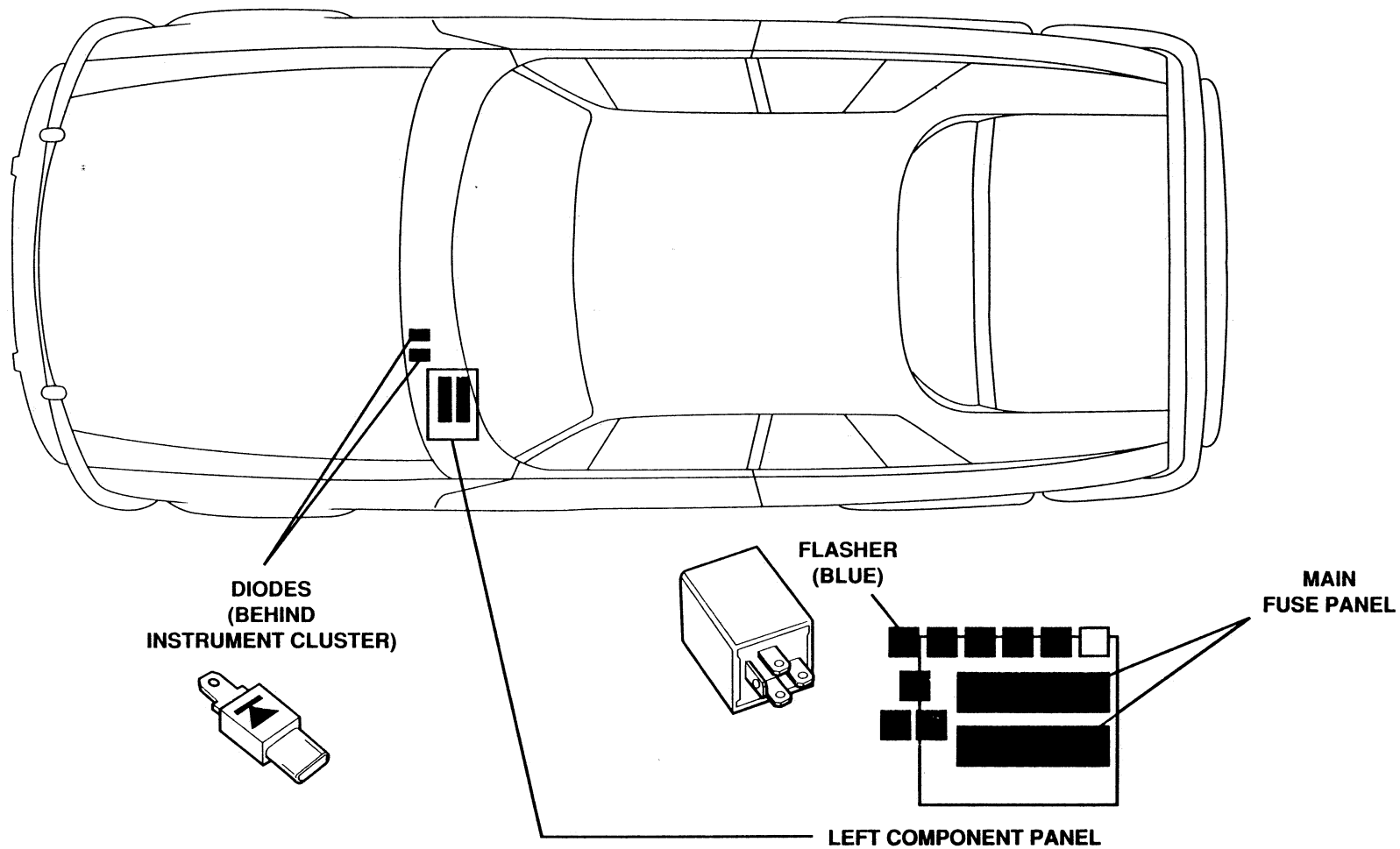


FIG 8.2

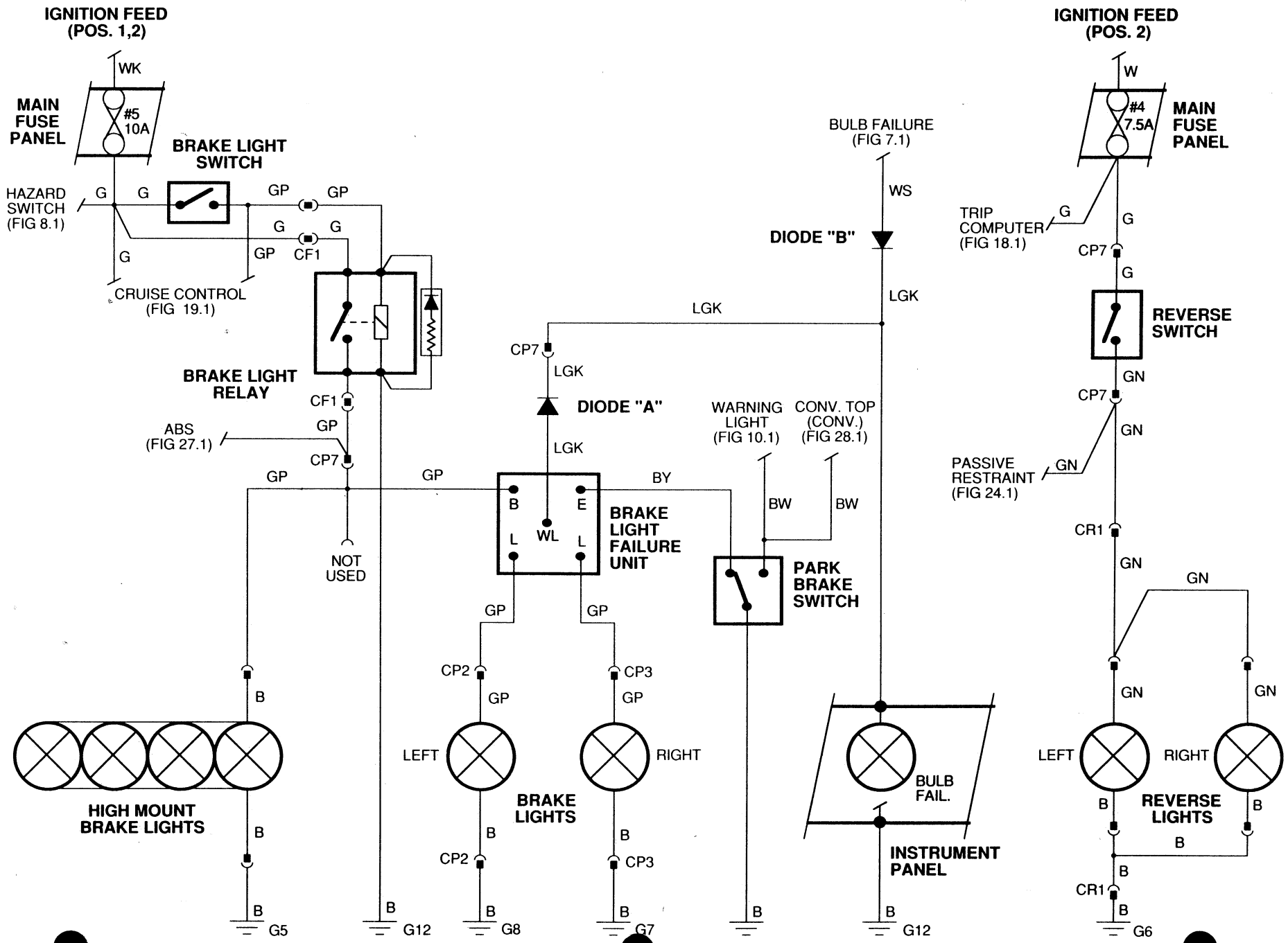
HAZARD; TURN SIGNALS

XJ-S
1989 MY

FIG 9.1

BRAKE LIGHTS; REVERSE LIGHTS

XJ-S
1989 MY



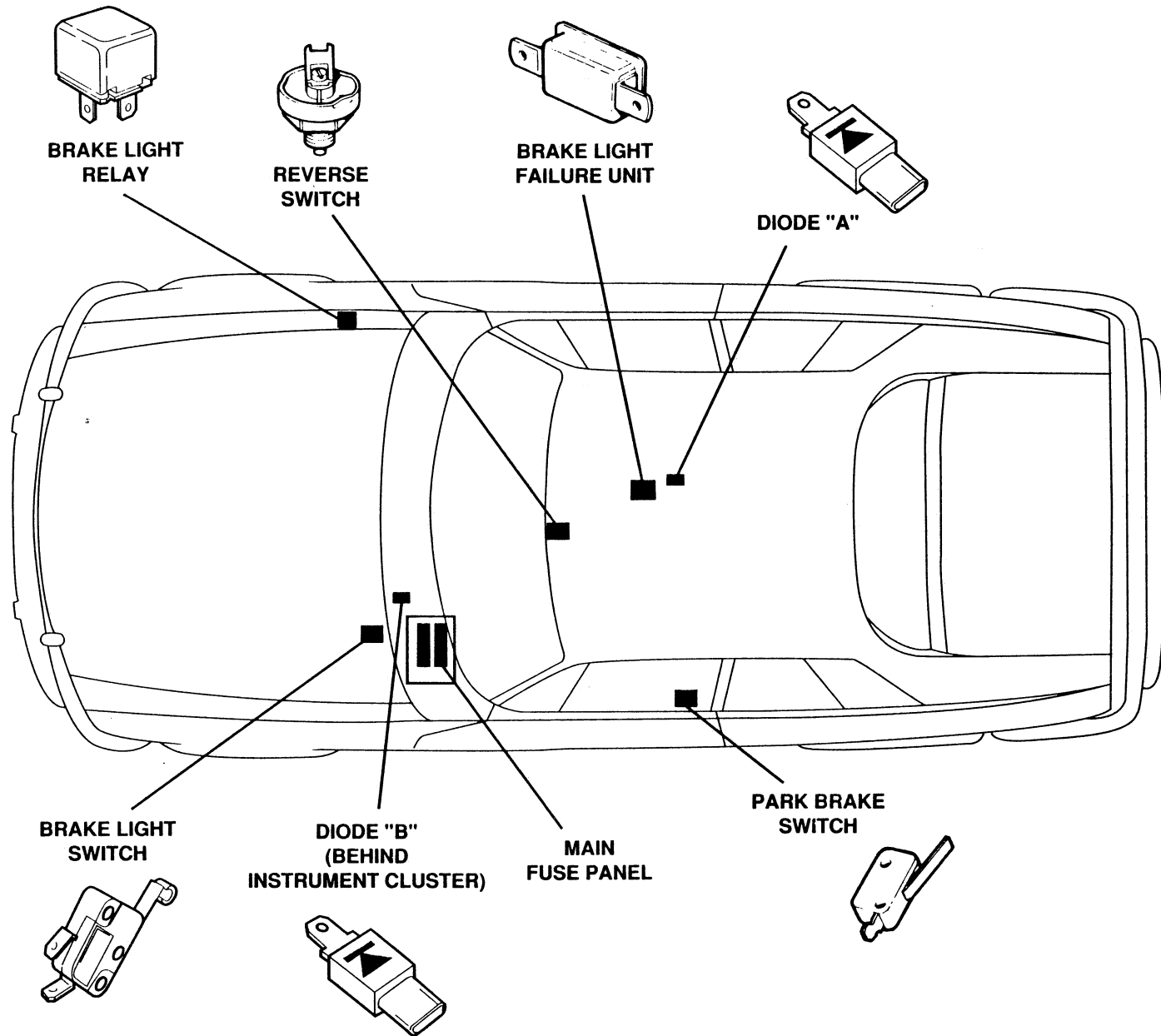
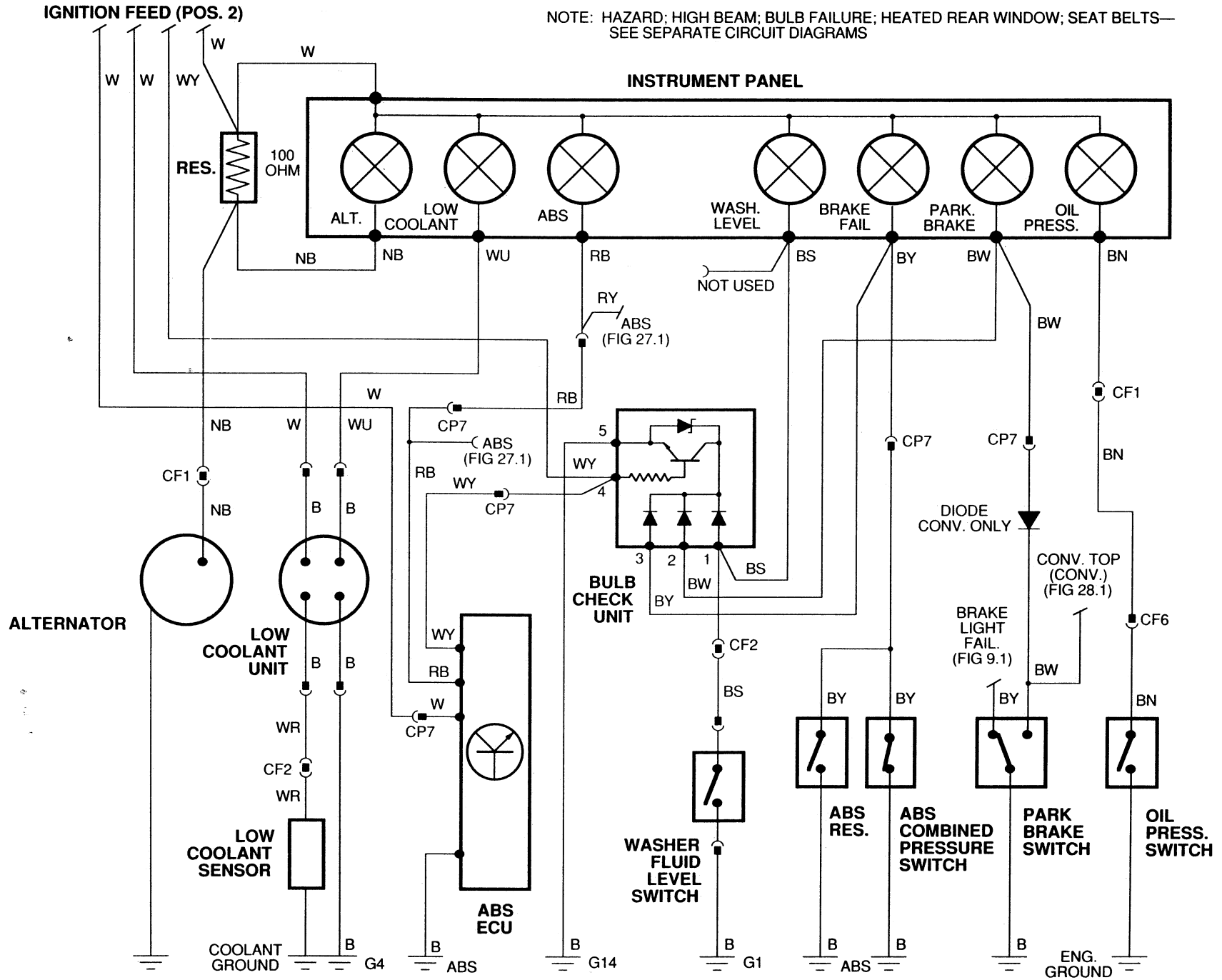


FIG 9.2

BRAKE LIGHTS; REVERSE LIGHTS

XJ-S
1989 MY



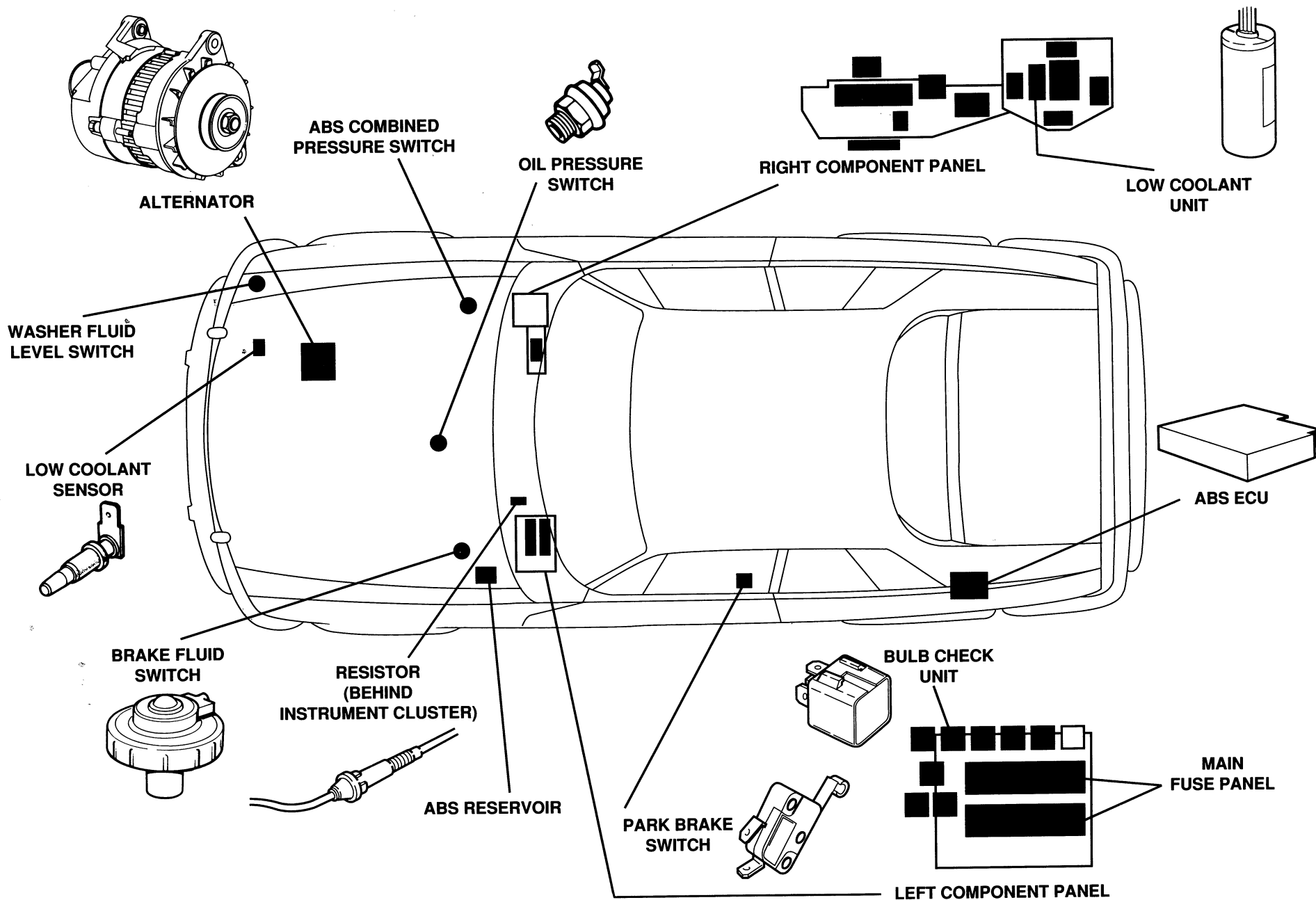


FIG 10.2

WARNING LIGHTS

XJ-S
1989 MY

FIG 11.1

INTERIOR LIGHTING (COUPE)

XJ-S
1989 MY

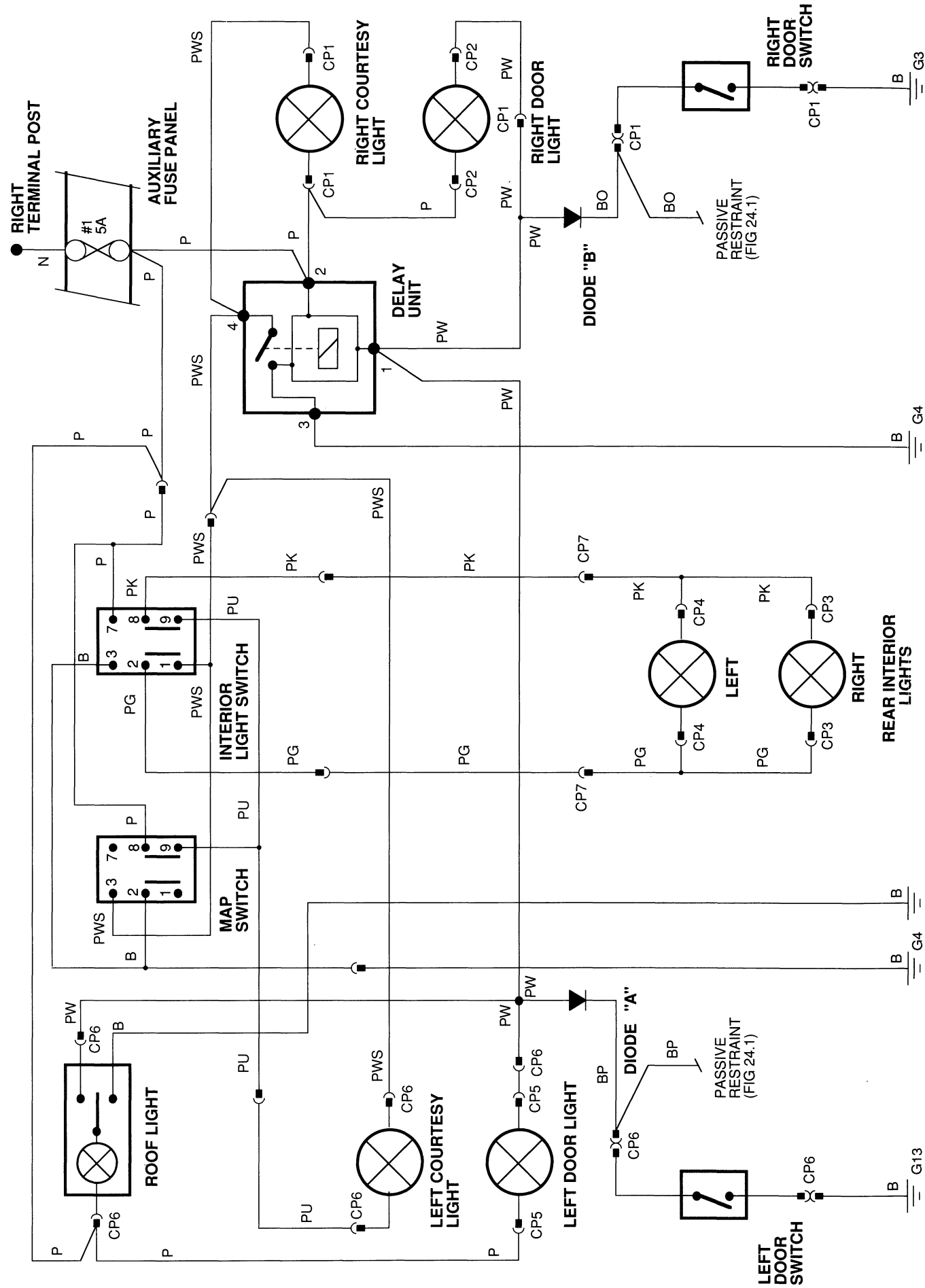
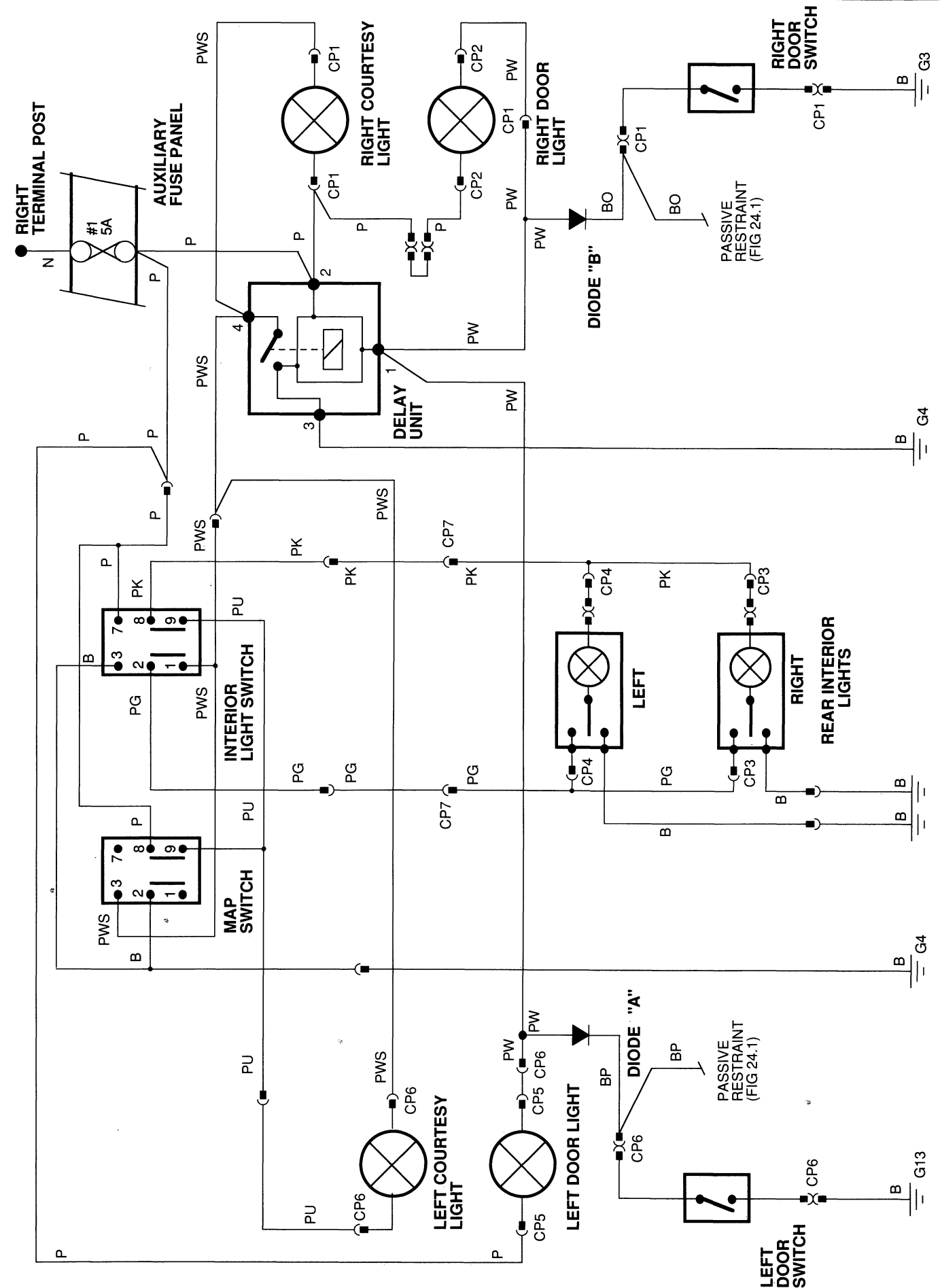


FIG 11.2

INTERIOR LIGHTING (CONV.)

XJ-S
1989 MY



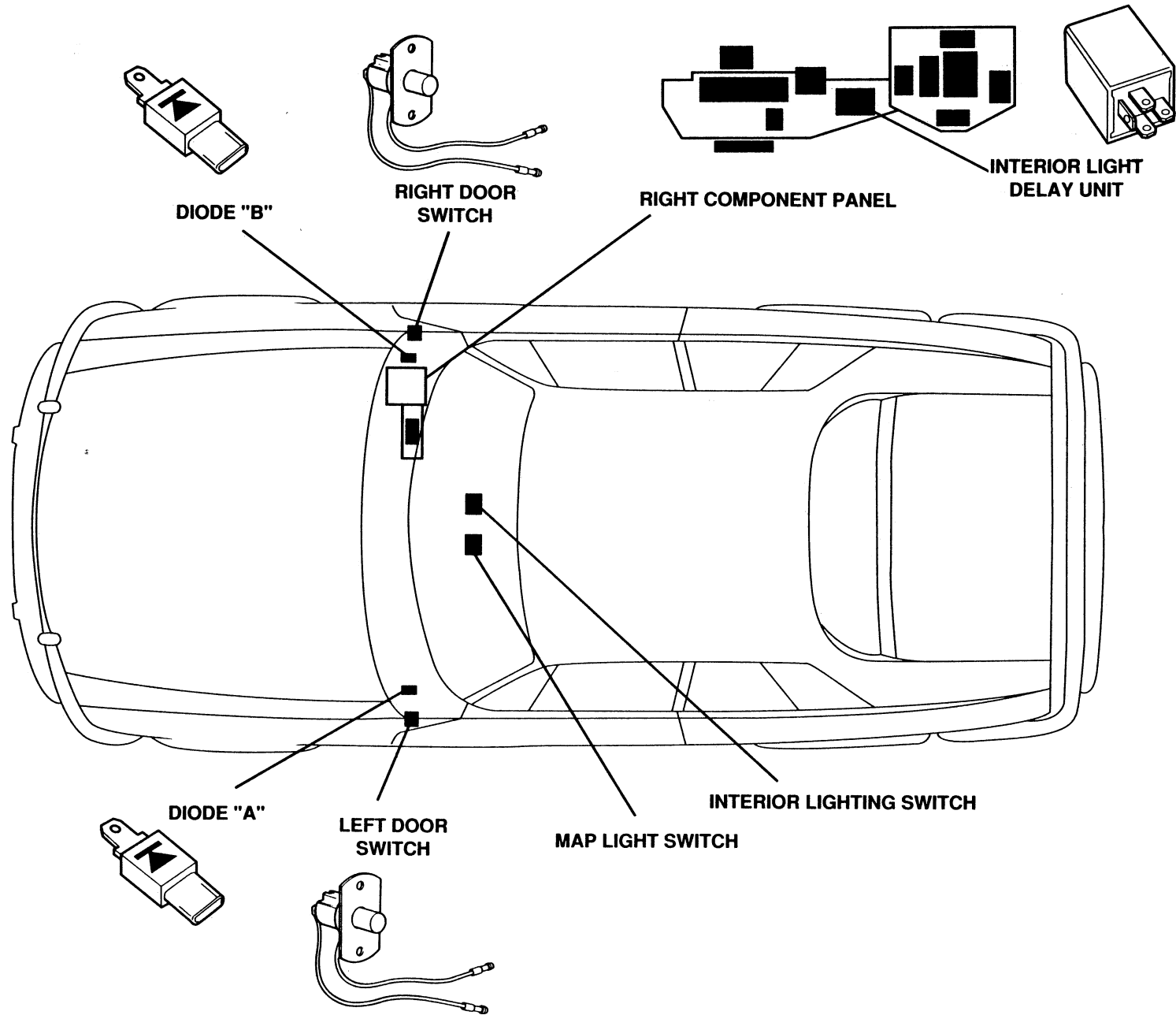
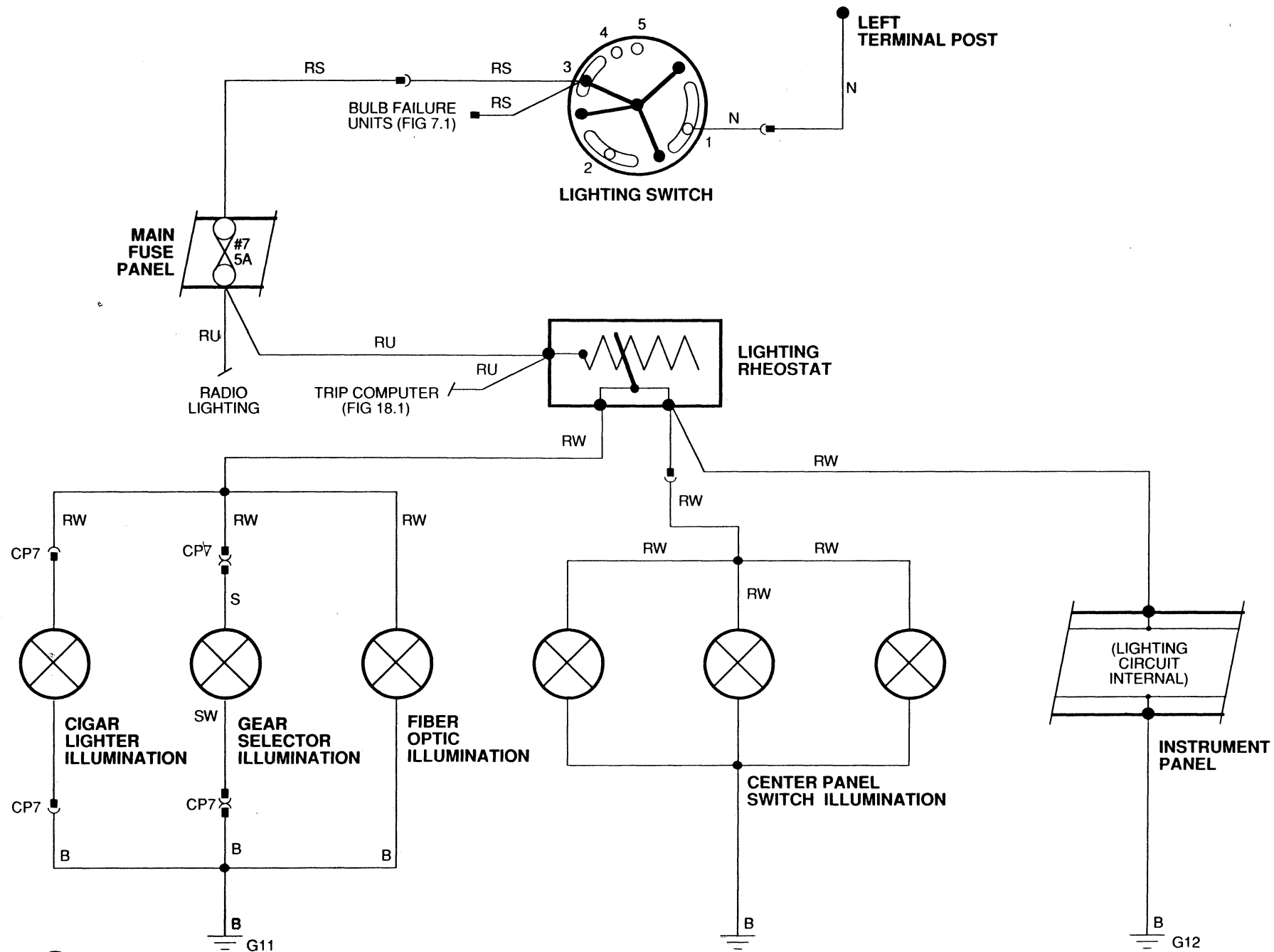


FIG 11.3

PARKING LIGHTS; MARKER LIGHTS

XJ-S
1989 MY



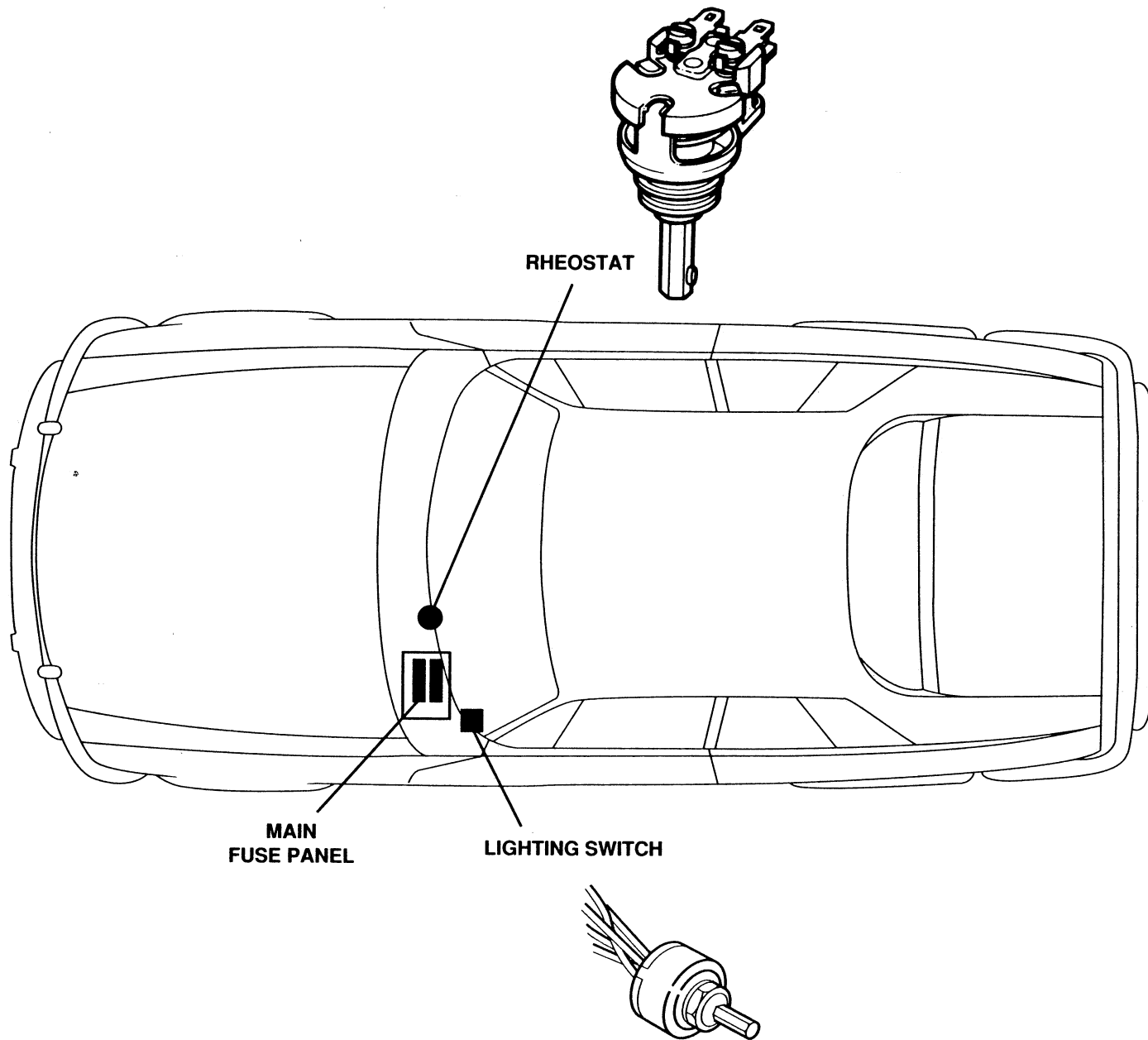


FIG 12.2

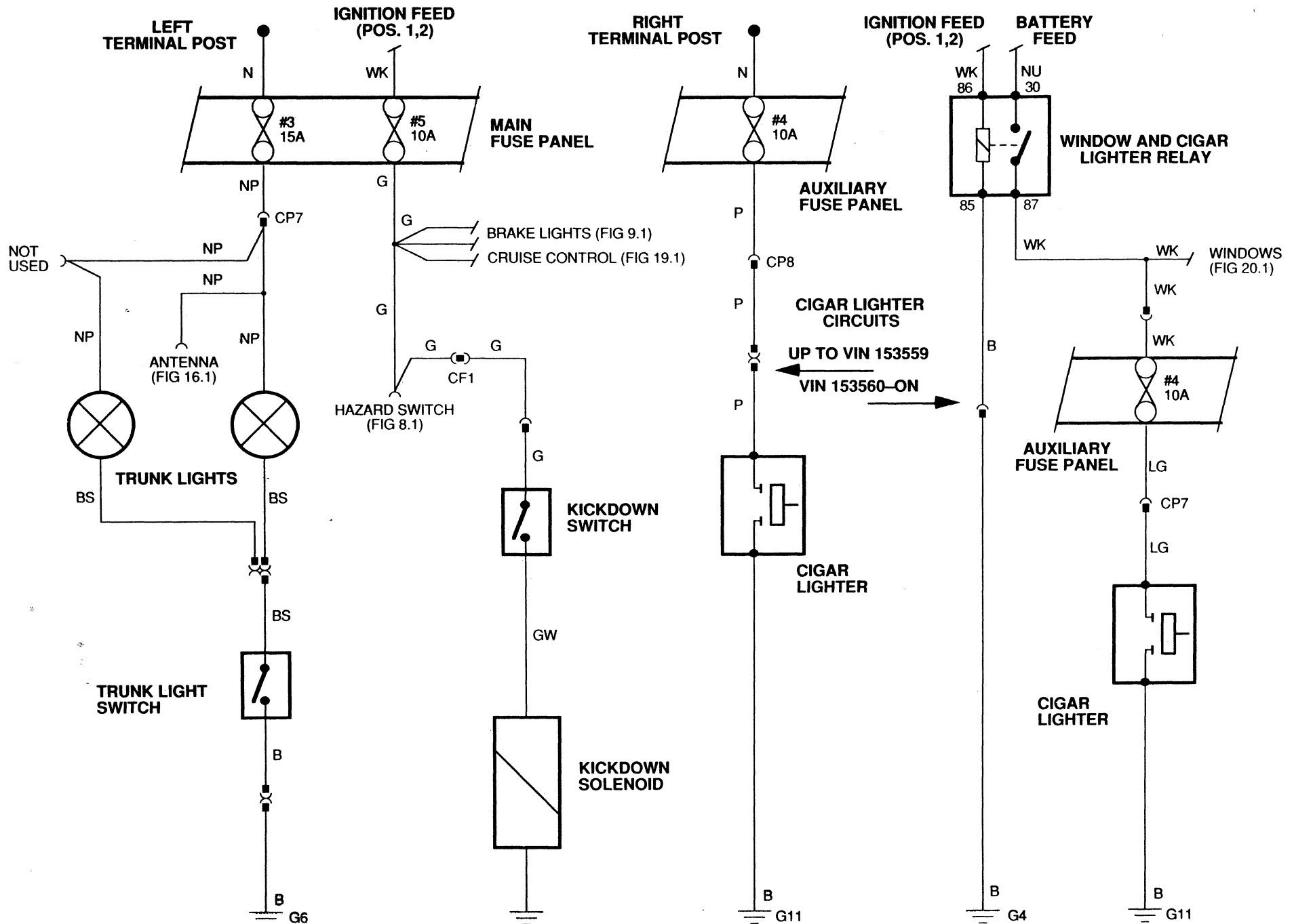
PANEL LIGHTS

XJ-S
1989 MY

FIG 13.1

TRUNK LIGHTS; TRANSMISSION KICKDOWN; CIGAR LIGHTER

XJ-S
1989 MY



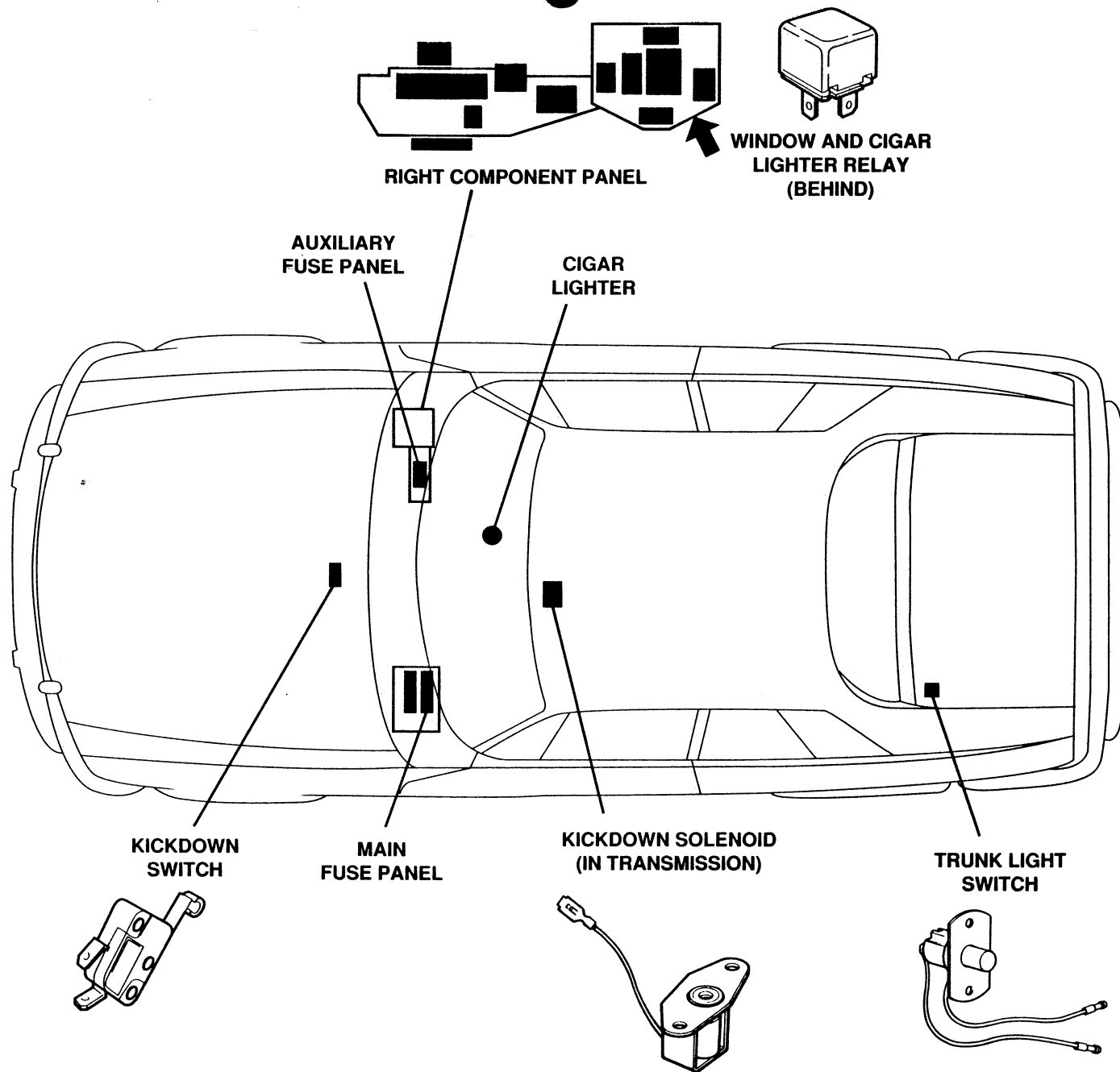
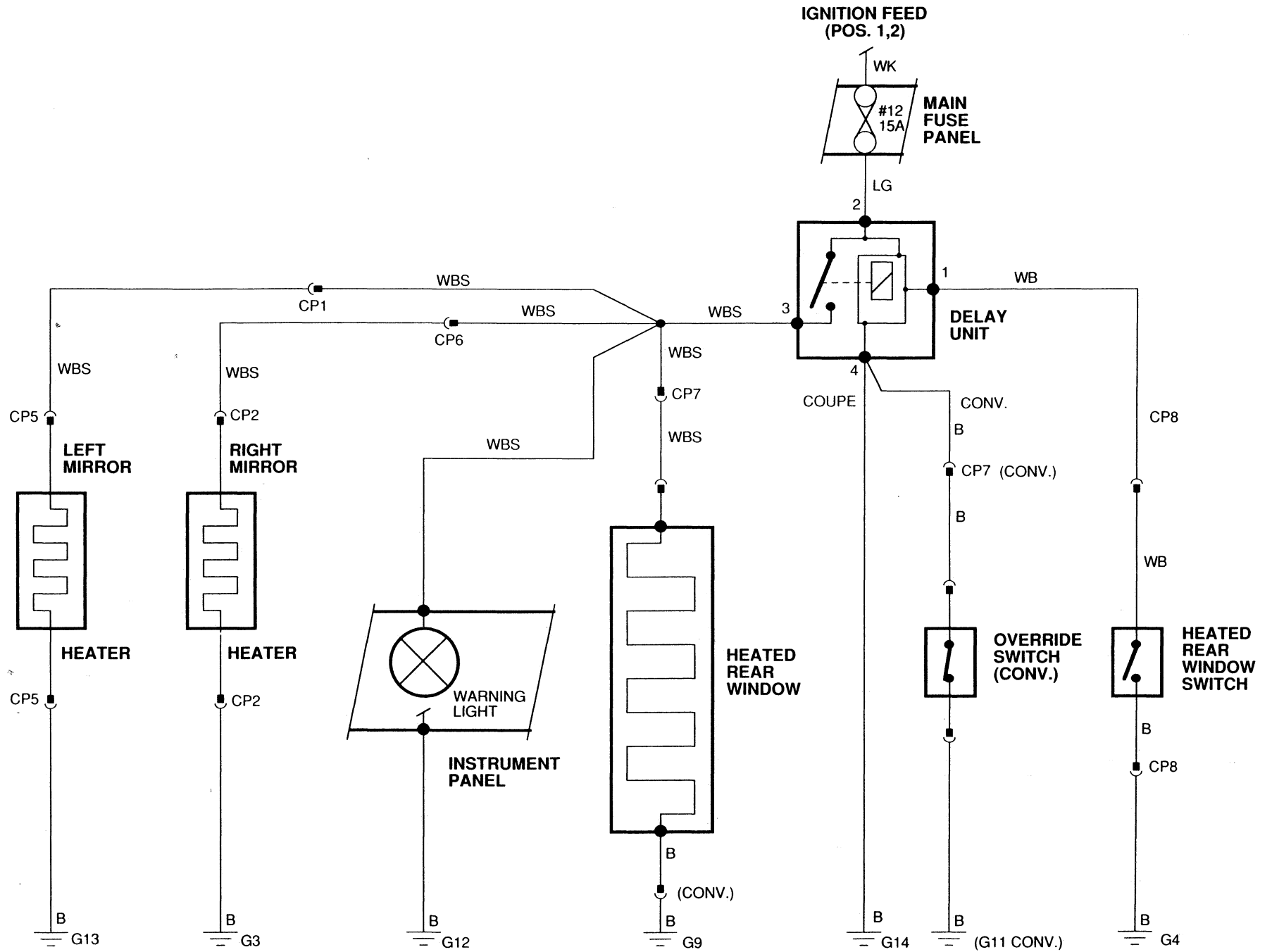


FIG 13.2

TRUNK LIGHTS; TRANSMISSION KICKDOWN; CIGAR LIGHTER

XJ-S
1989 MY



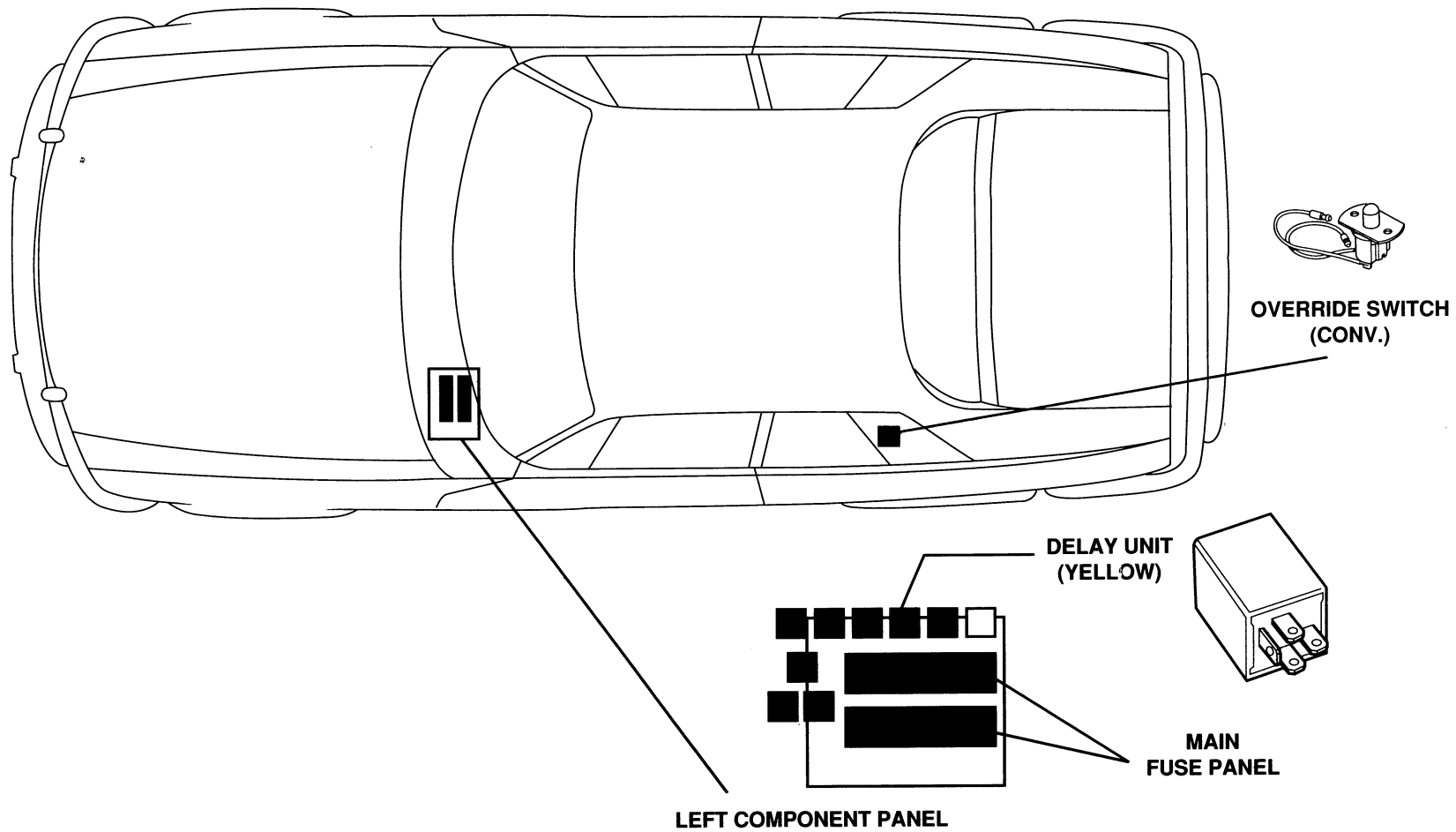


FIG 14.2

HEATED REAR WINDOW; HEATED MIRRORS

XJ-S
1989 MY

FIG 15.1

WINDSHIELD WIPERS, WASHERS
(UP TO VIN 154404)

XJ-S
1989 MY

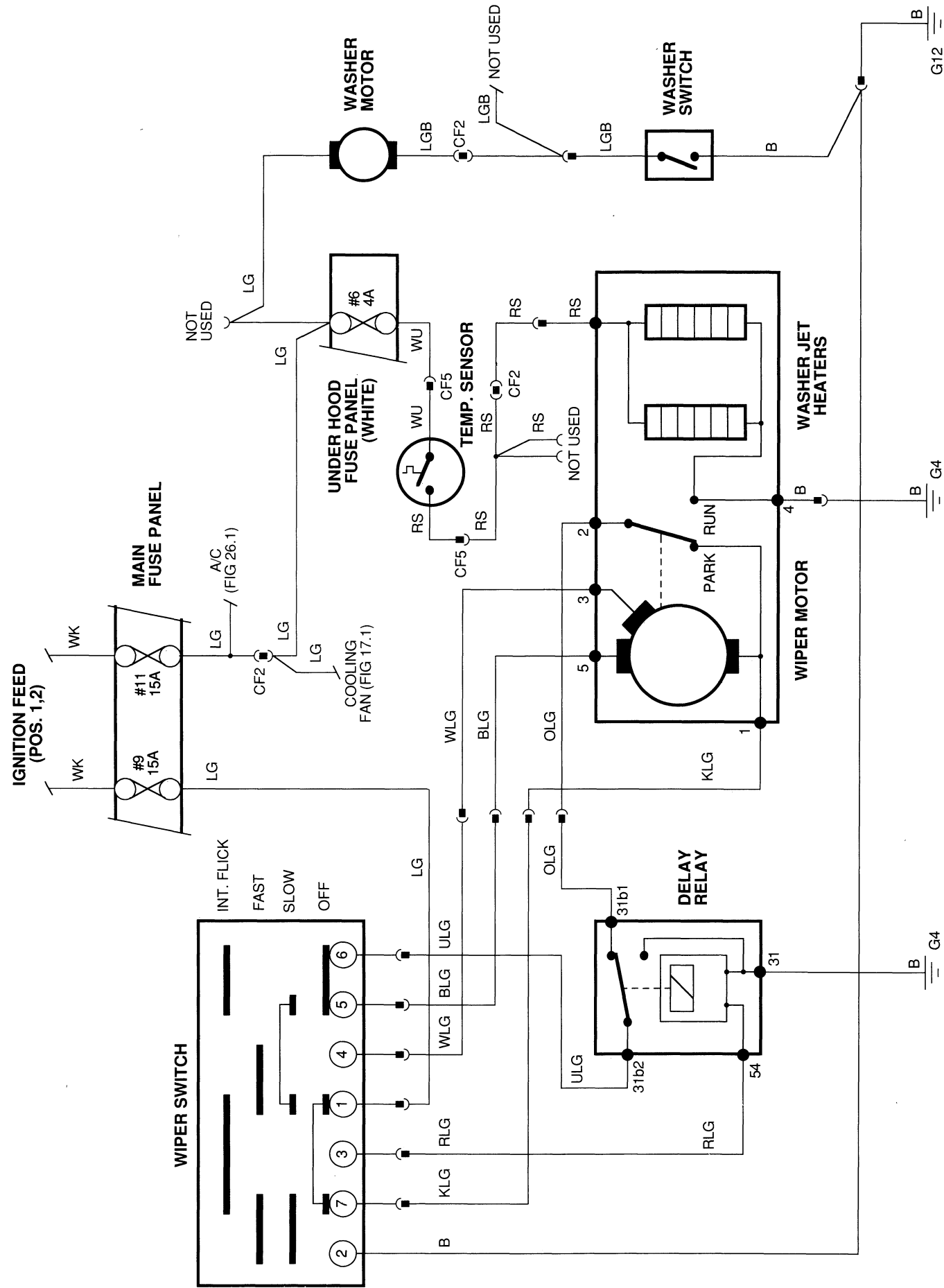


FIG 15.2

WINDSHIELD WIPERS, WASHERS
(VIN 154405-156988)

XJ-S
1989 MY

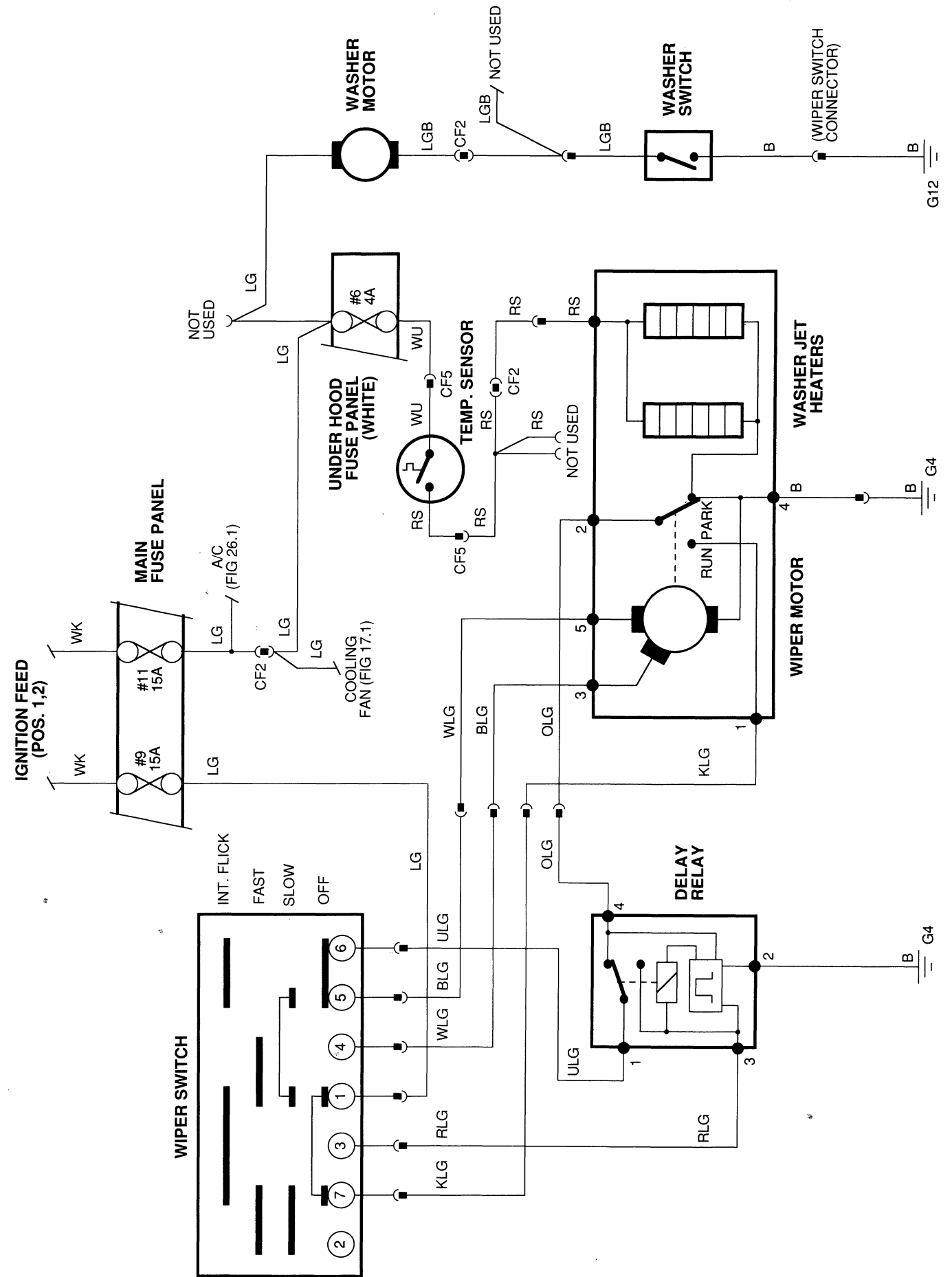


FIG 15.3

WINDSHIELD WIPERS, WASHERS (VIN 156989-ON)

XJ-S
1989 MY

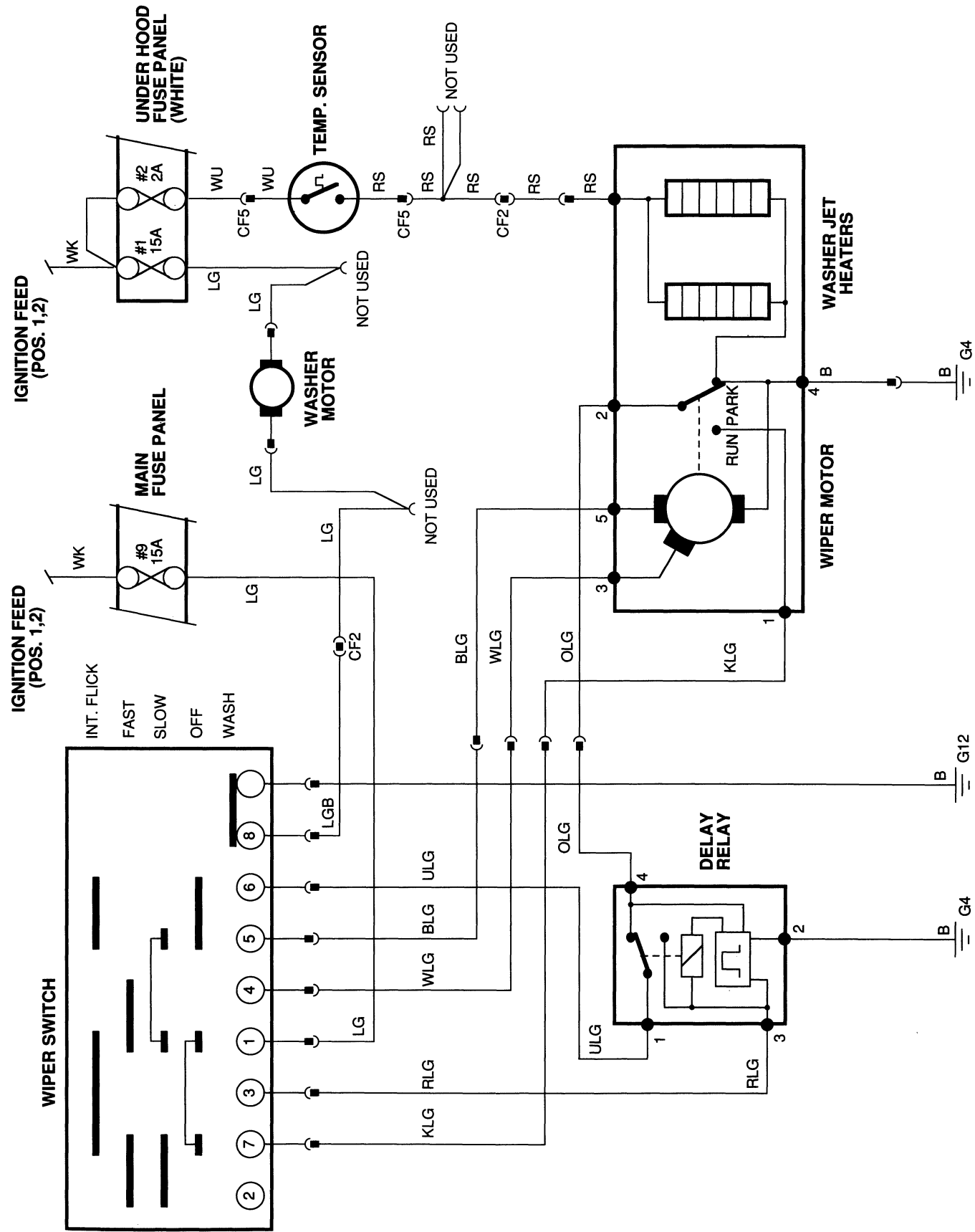
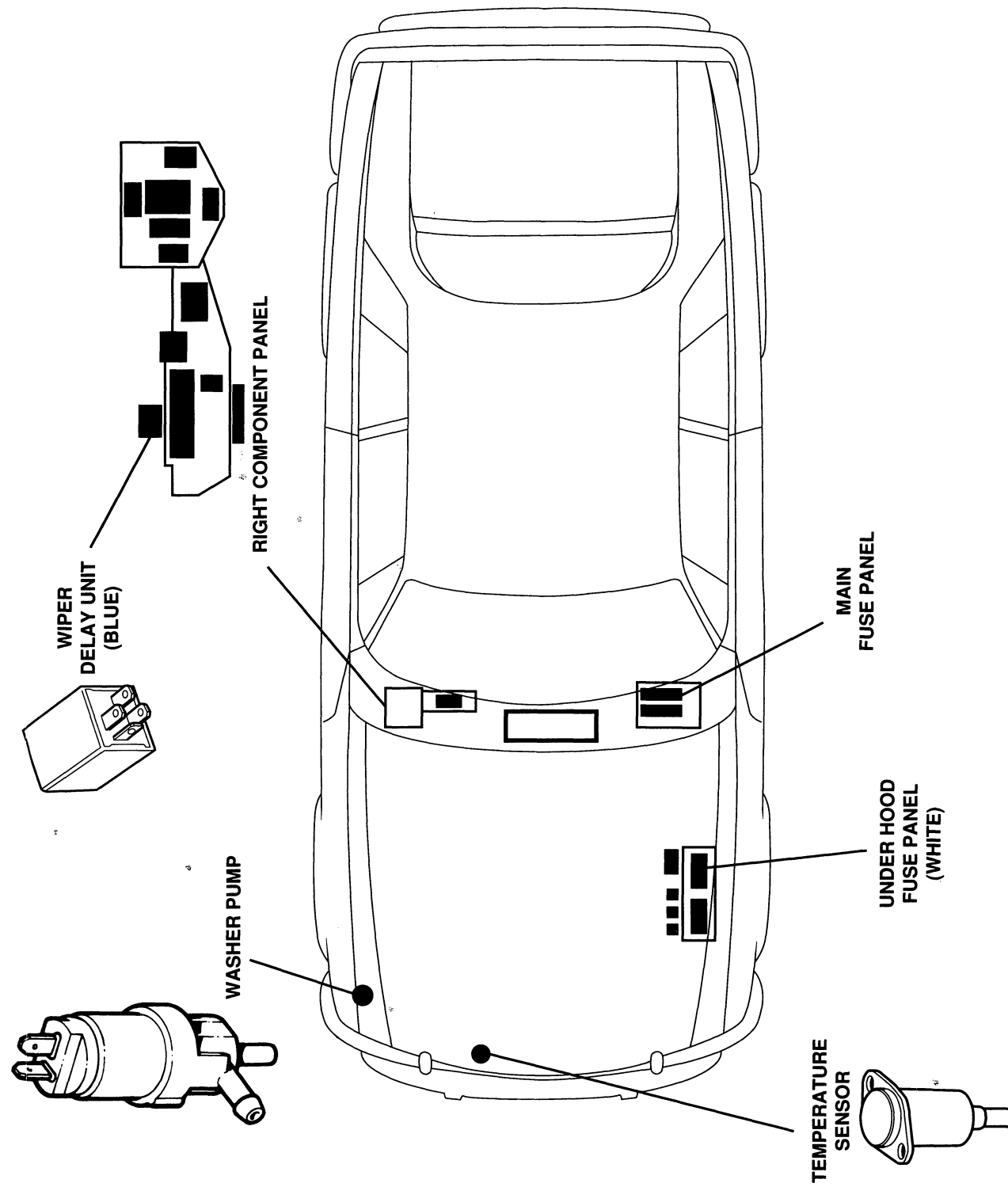
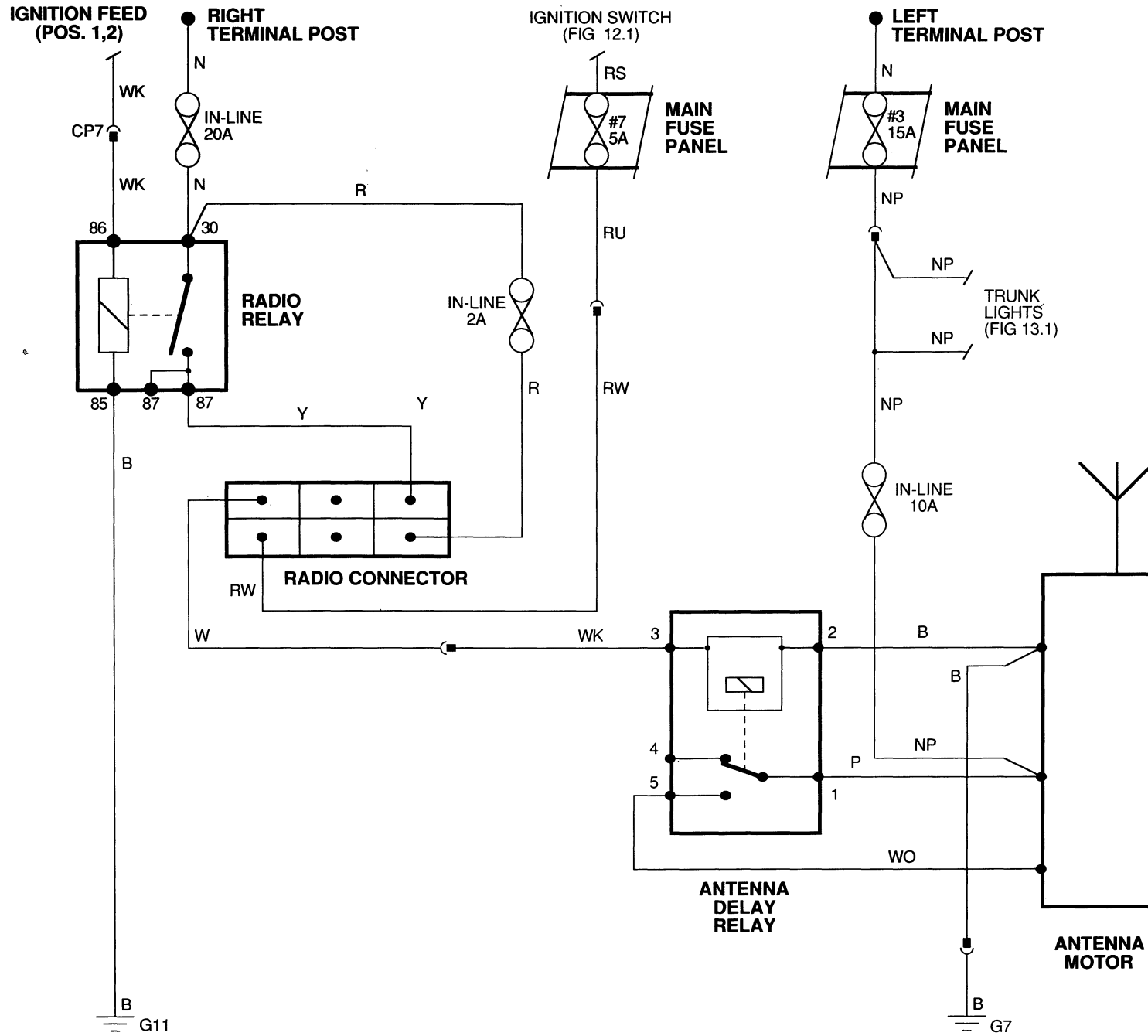


FIG 15.4

WINDSHIELD WIPERS, WASHERS

XJ-S
1989 MY





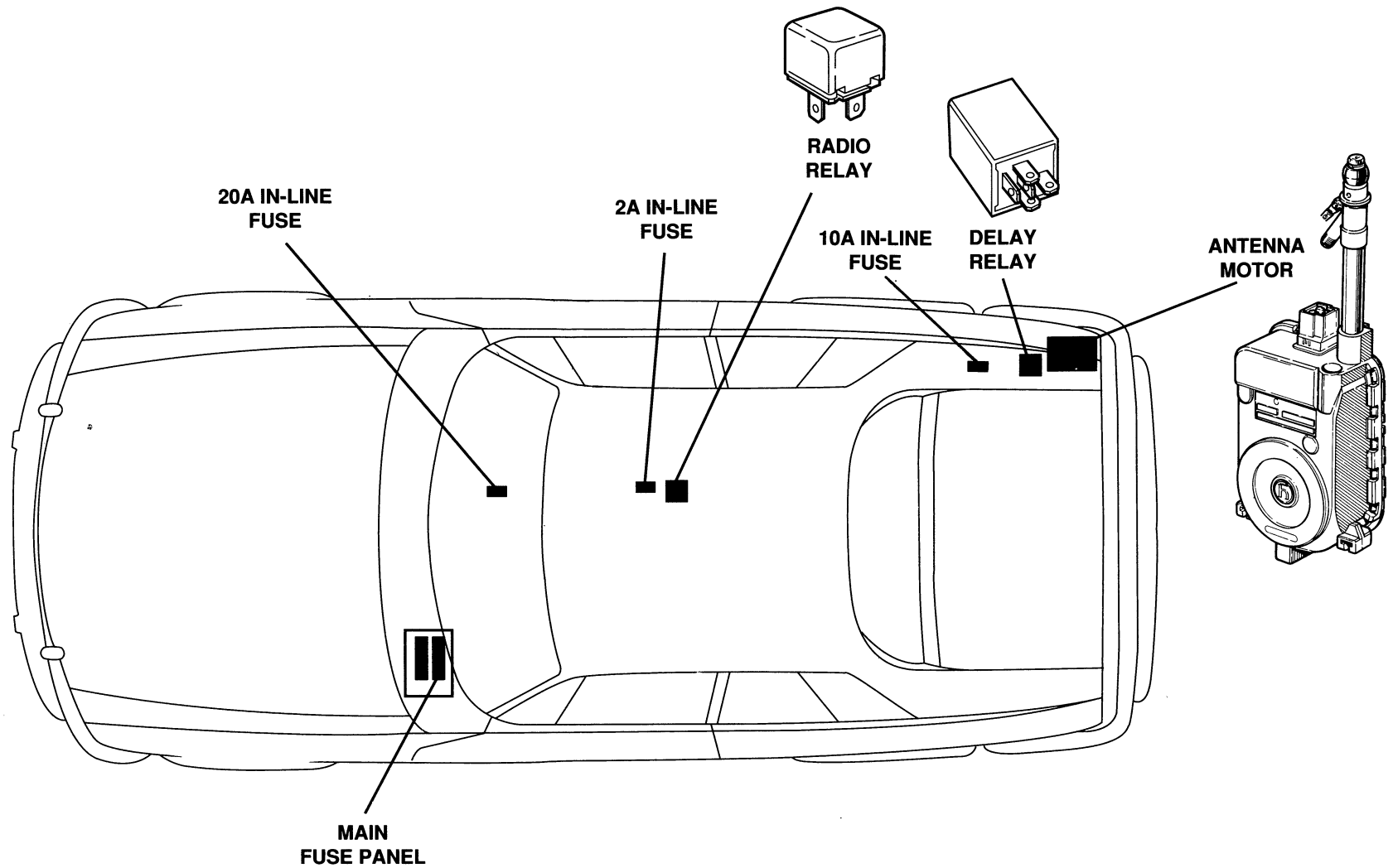


FIG 16.2

RADIO; ANTENNA

XJ-S
1989 MY

FIG 17.1

HORNS; COOLING FAN (UP TO VIN 156988)

XJ-S
1989 MY

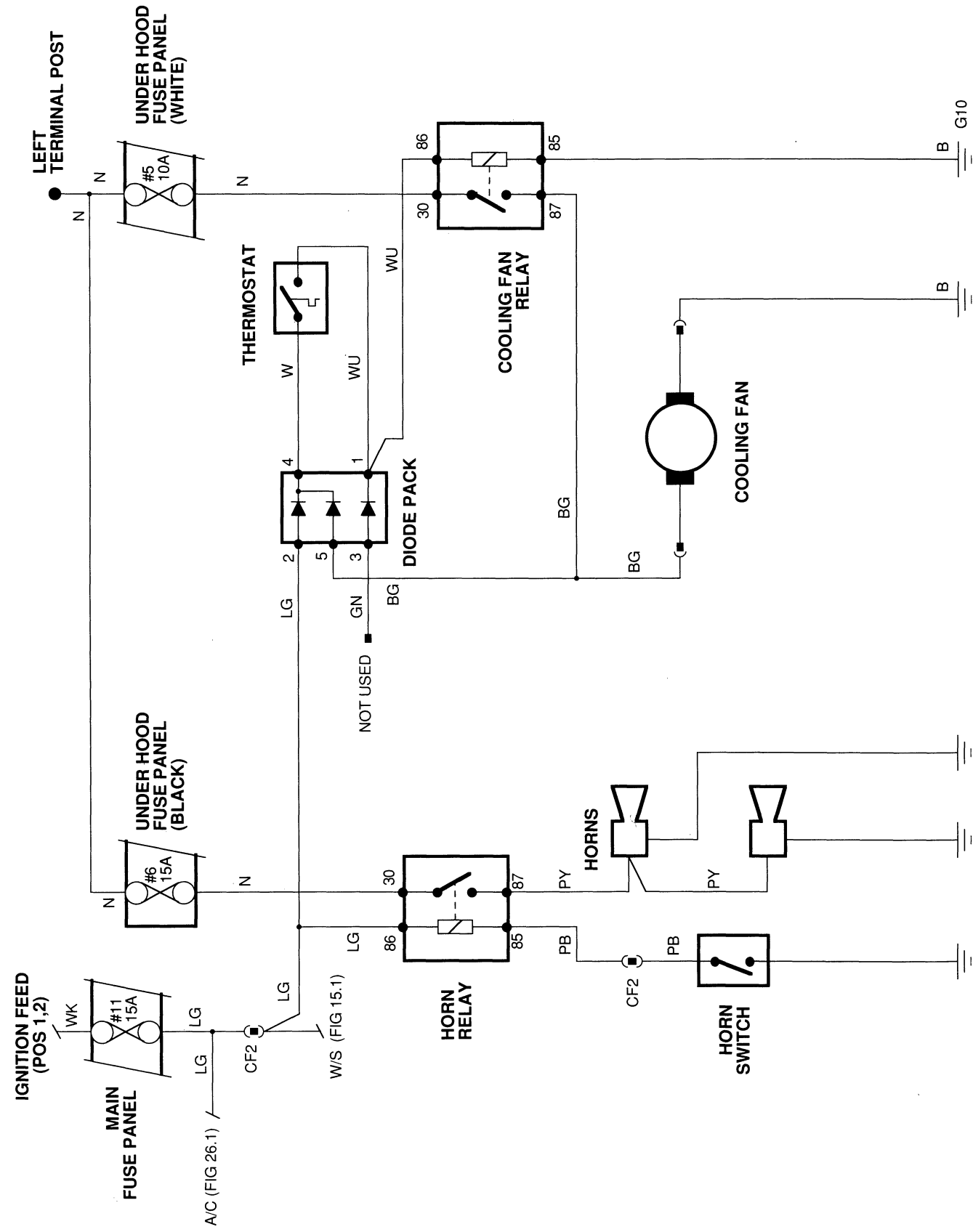
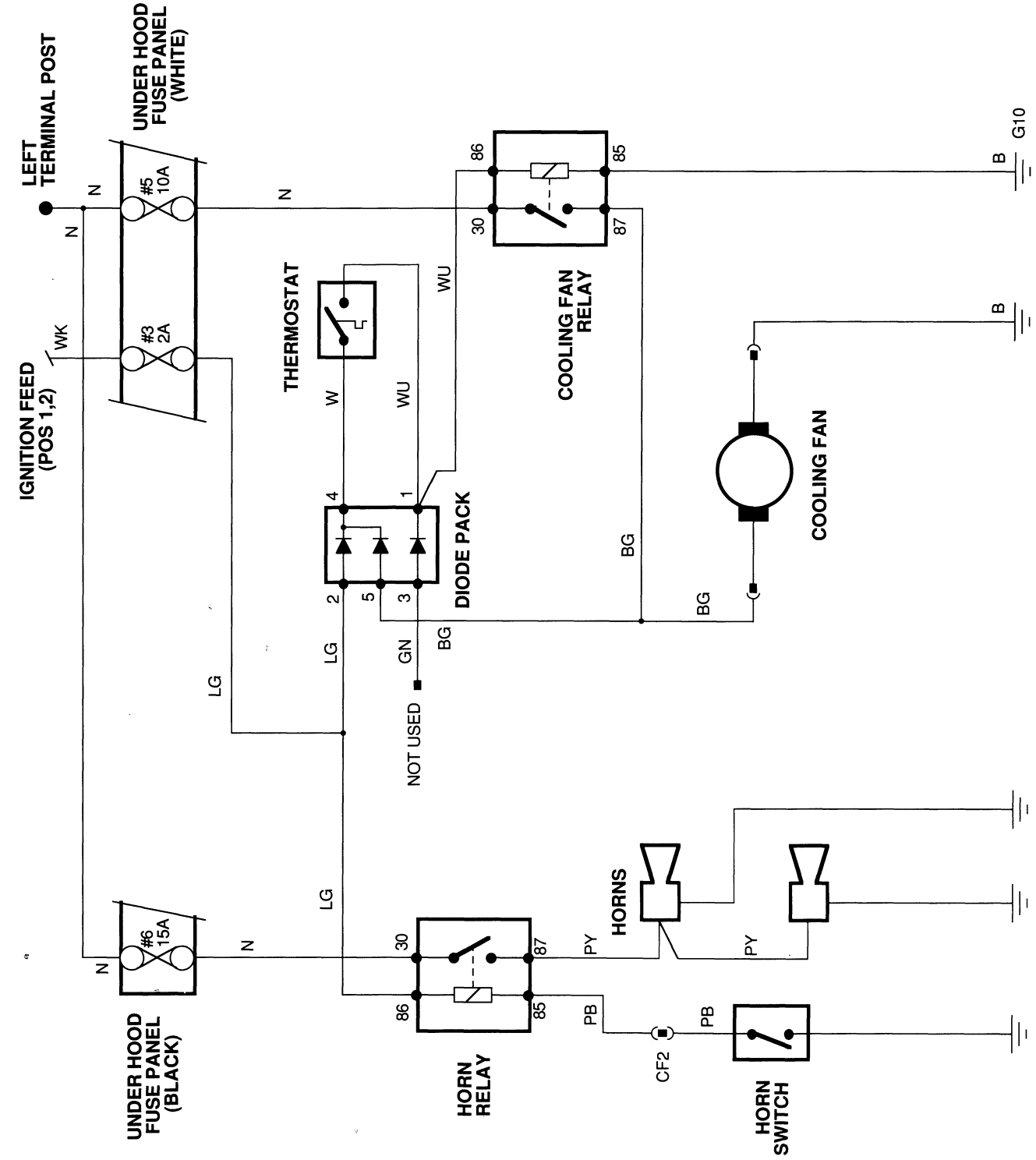


FIG 17.2

HORNS; COOLING FAN (VIN 156989-ON)

XJ-S
1989 MY



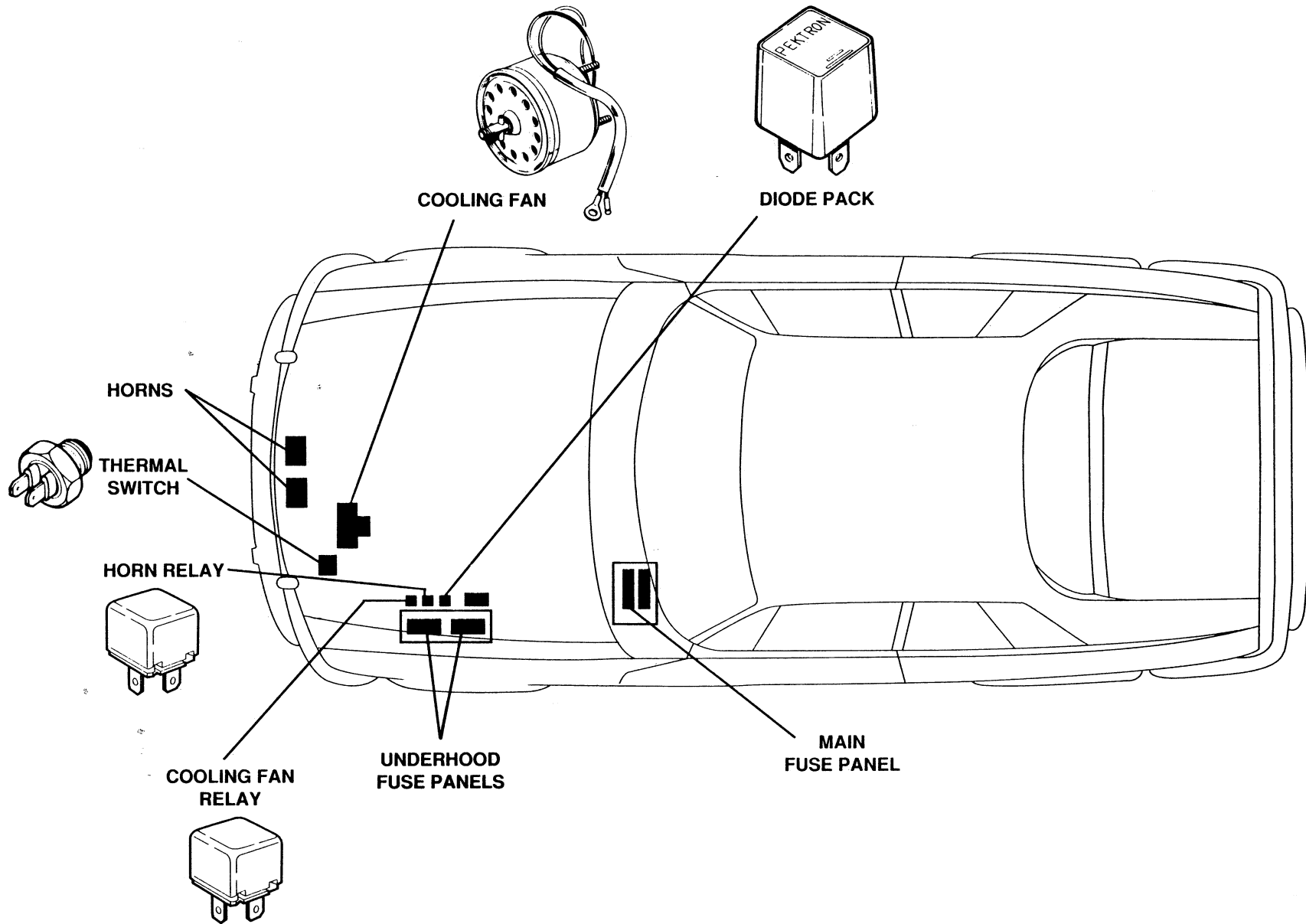
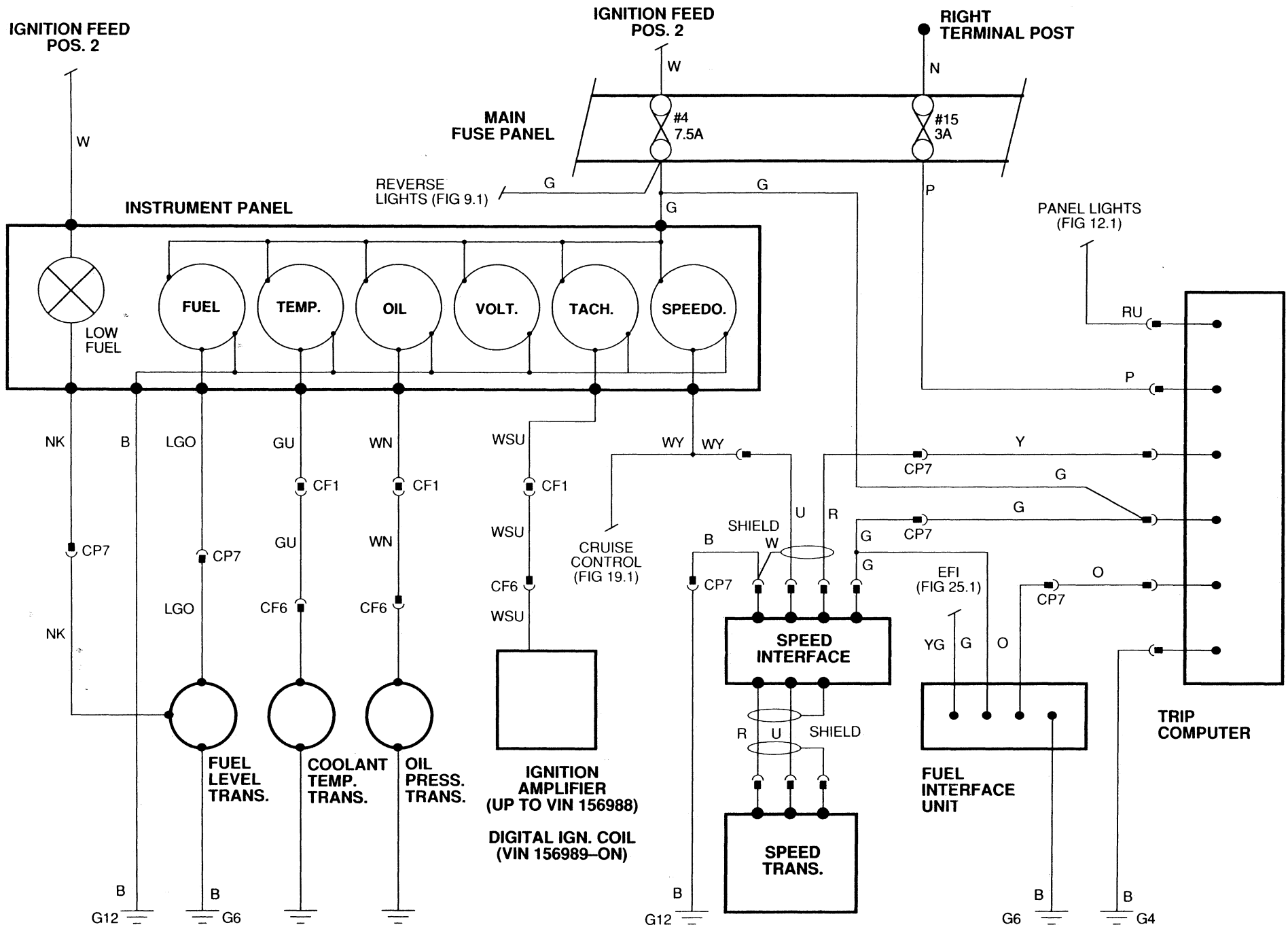


FIG 17.3

HORNS; COOLING FAN



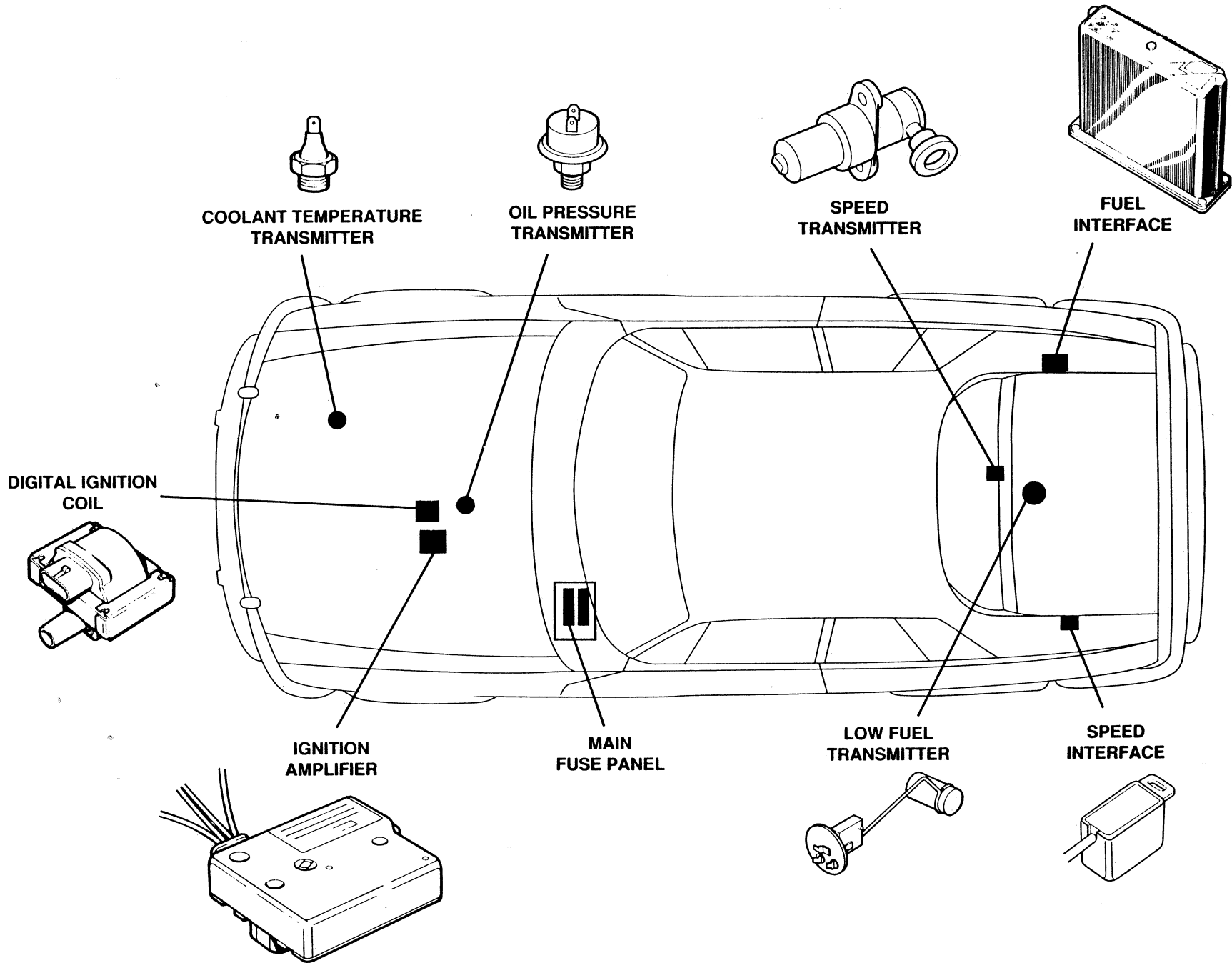
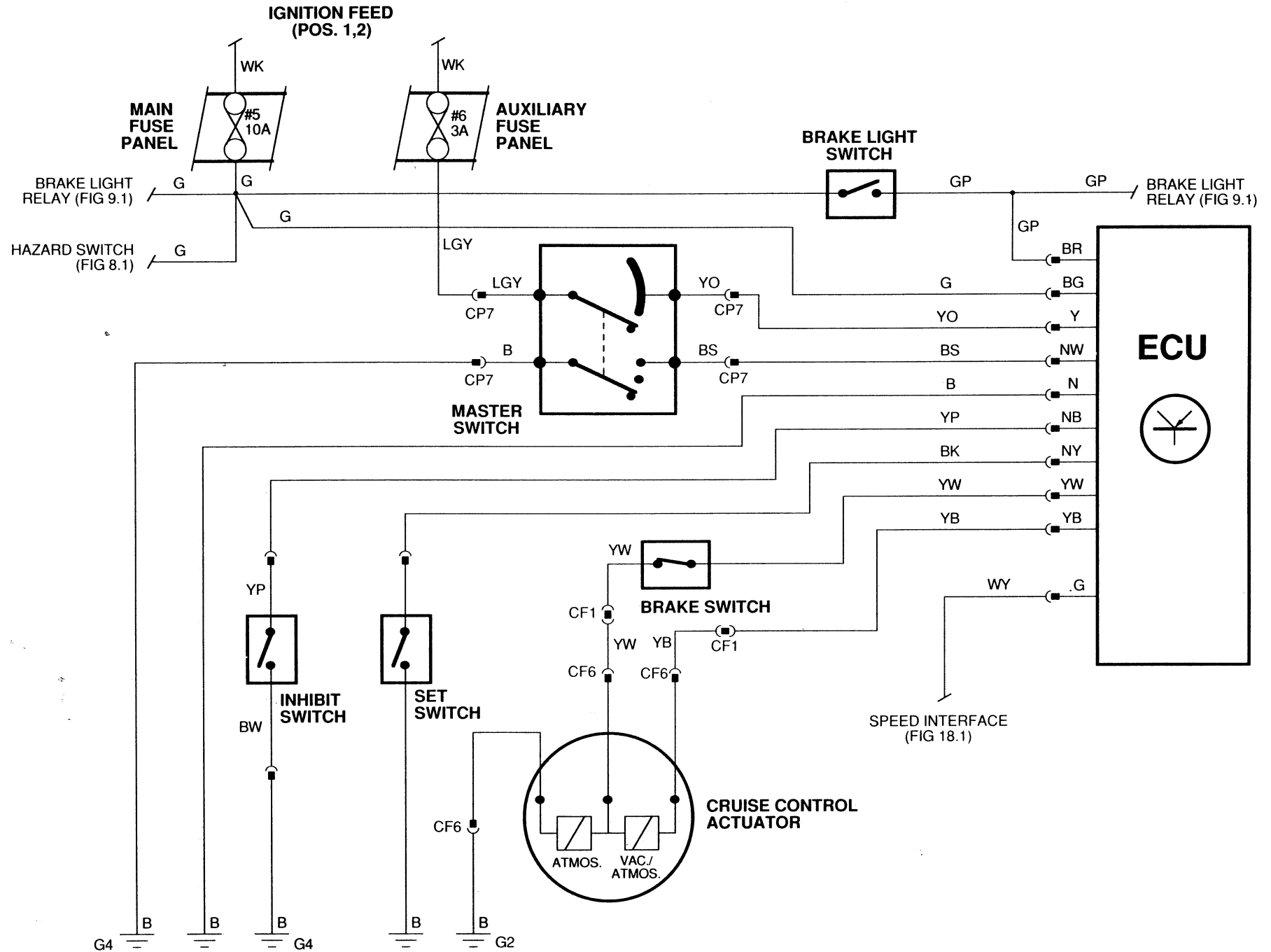


FIG 18.2

INSTRUMENTATION; TRIP COMPUTER

XJ-S
1989 MY



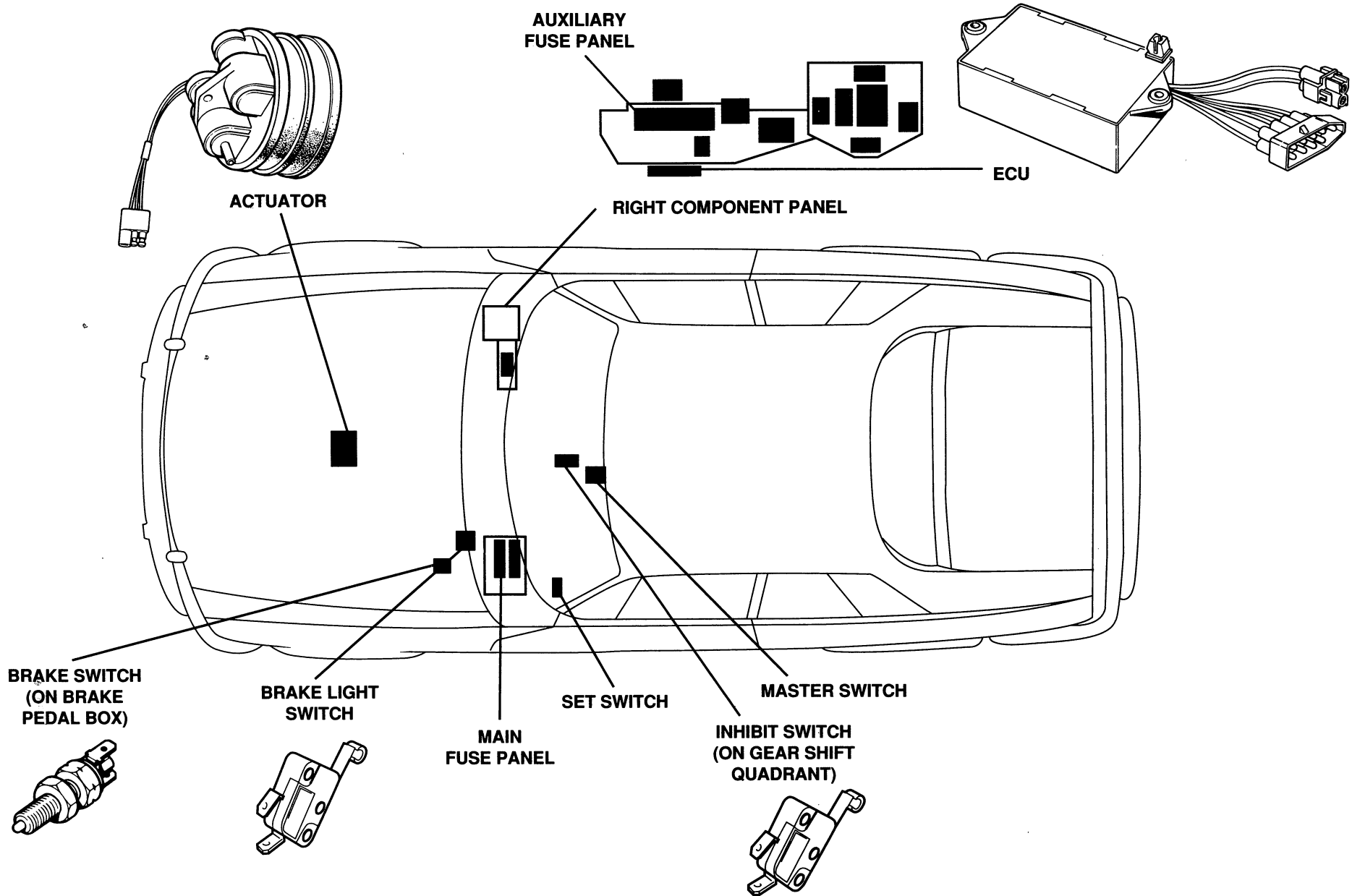


FIG 19.2

CRUISE CONTROL

XJ-S
1989 MY

FIG 20.1

POWER WINDOWS (UP TO VIN 156988)

XJ-S
1989 MY

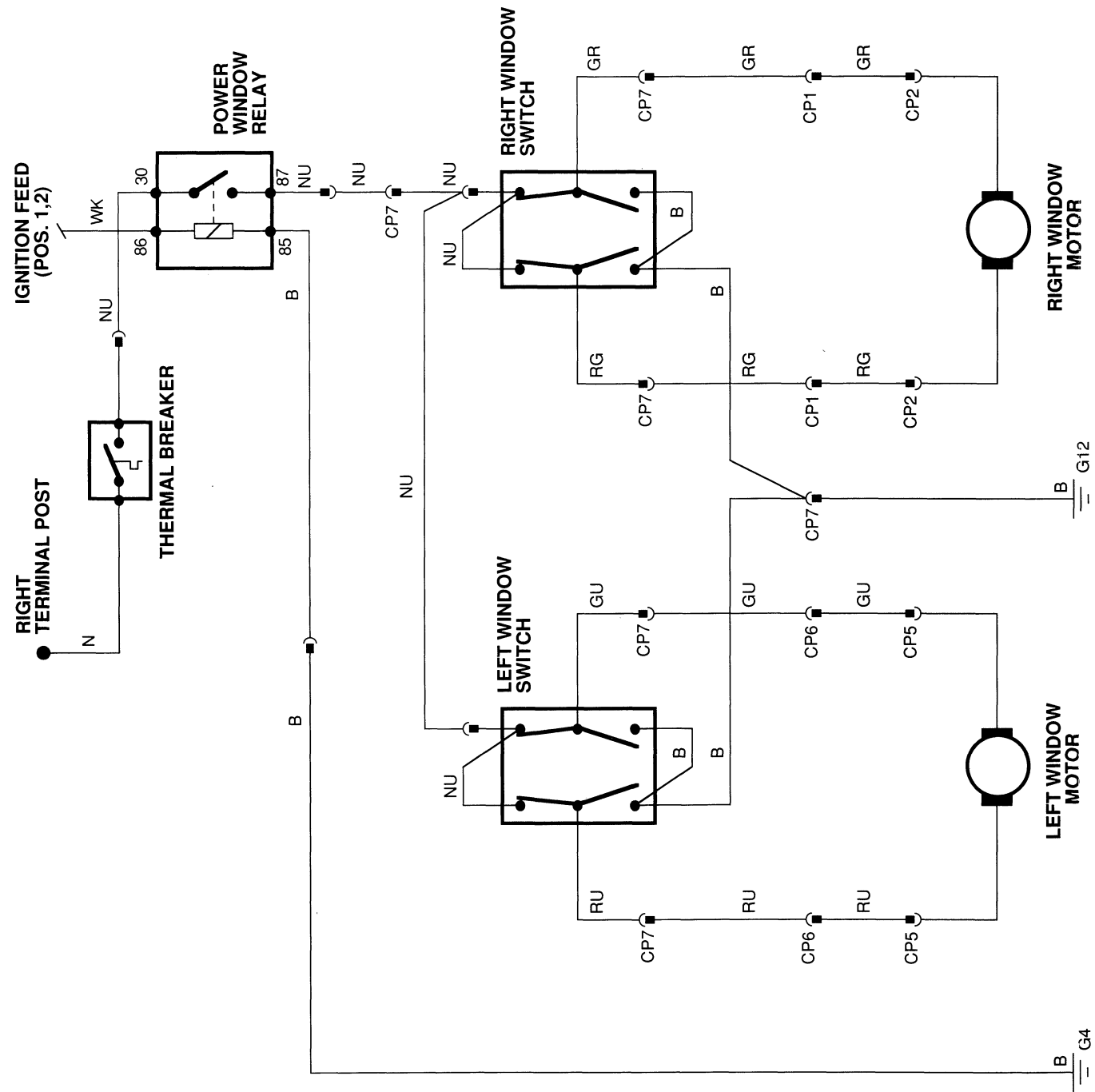
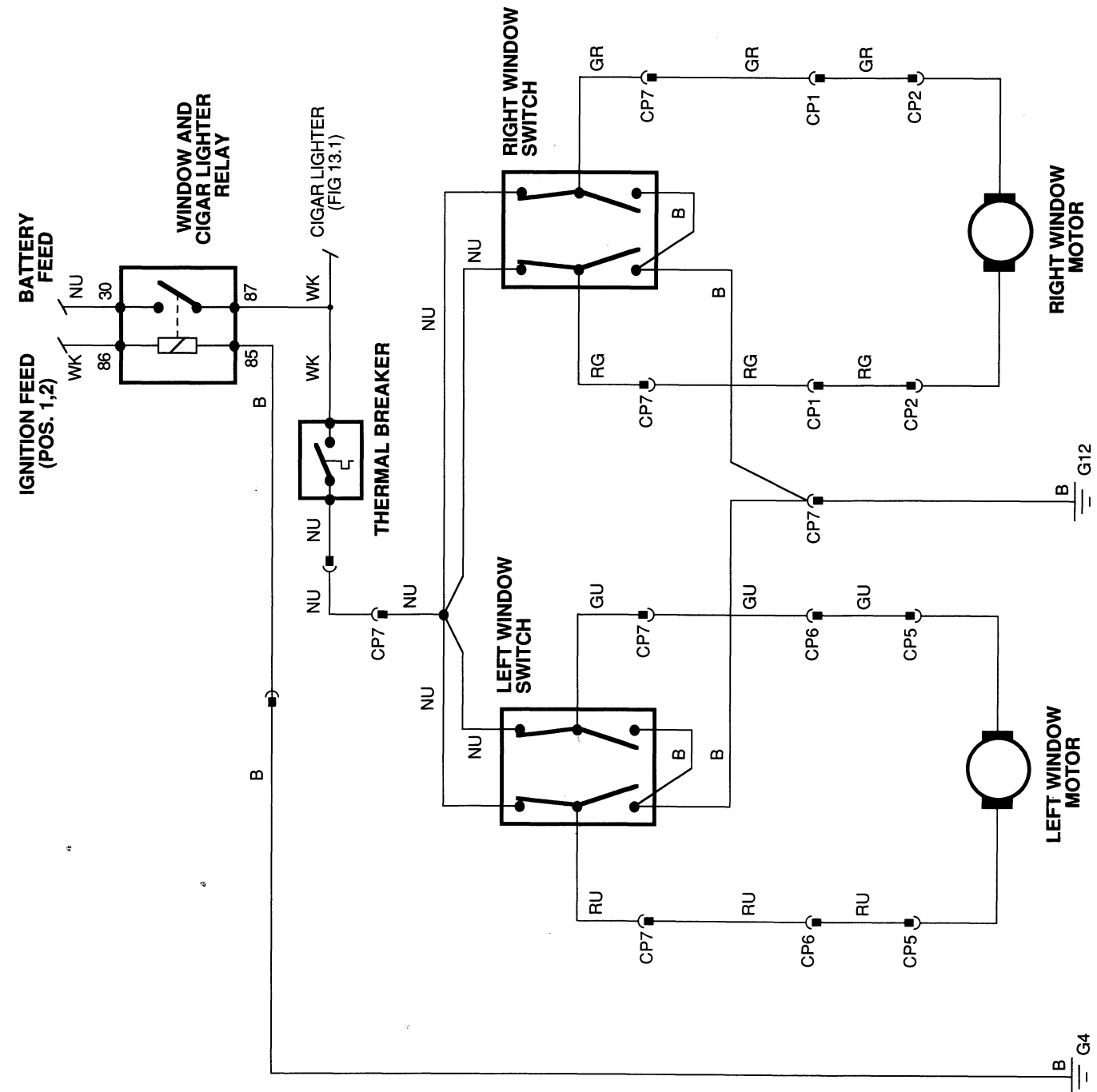


FIG 20.2

POWER WINDOWS (VIN 156989-ON)

XJ-S
1989 MY



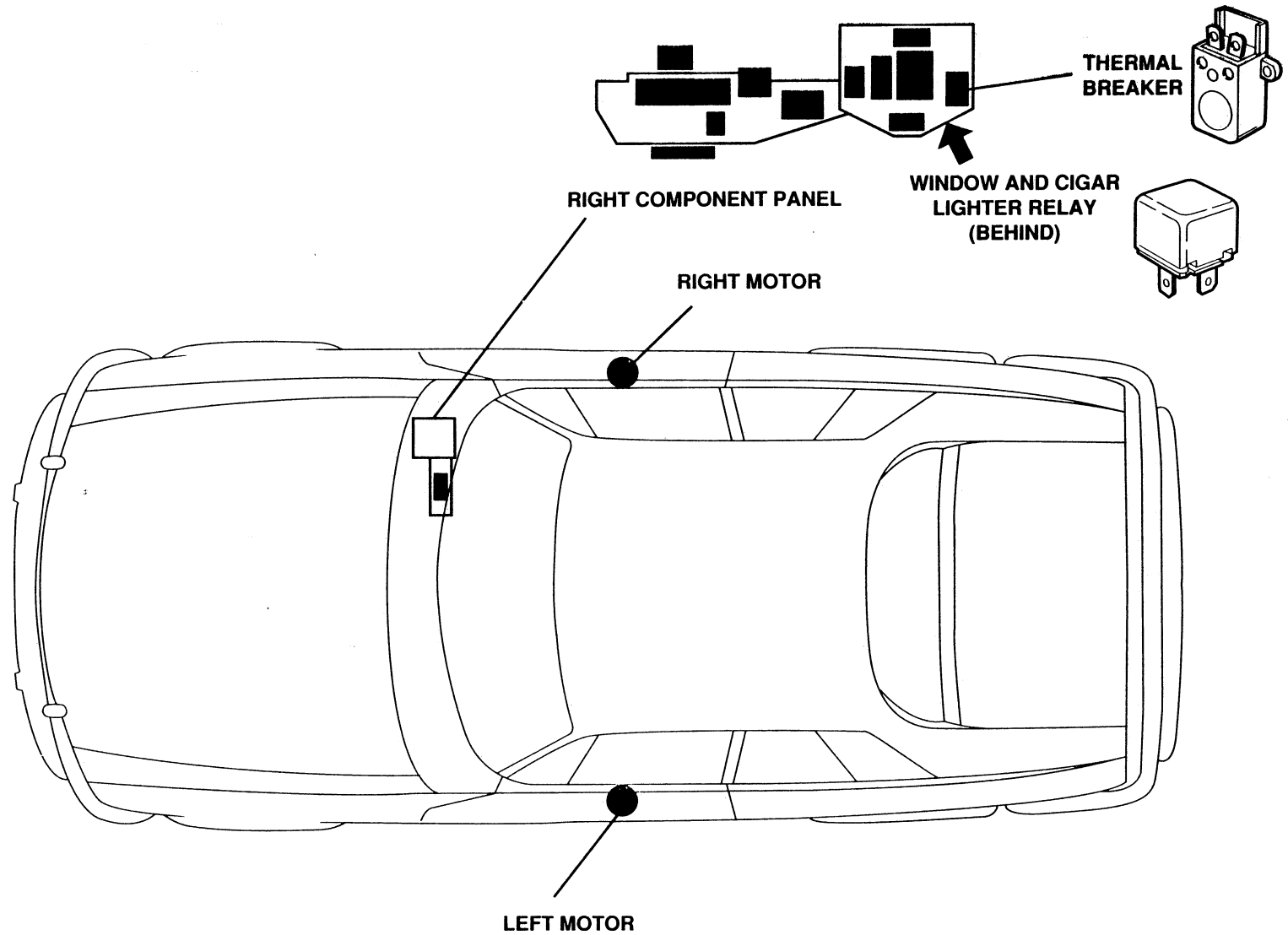
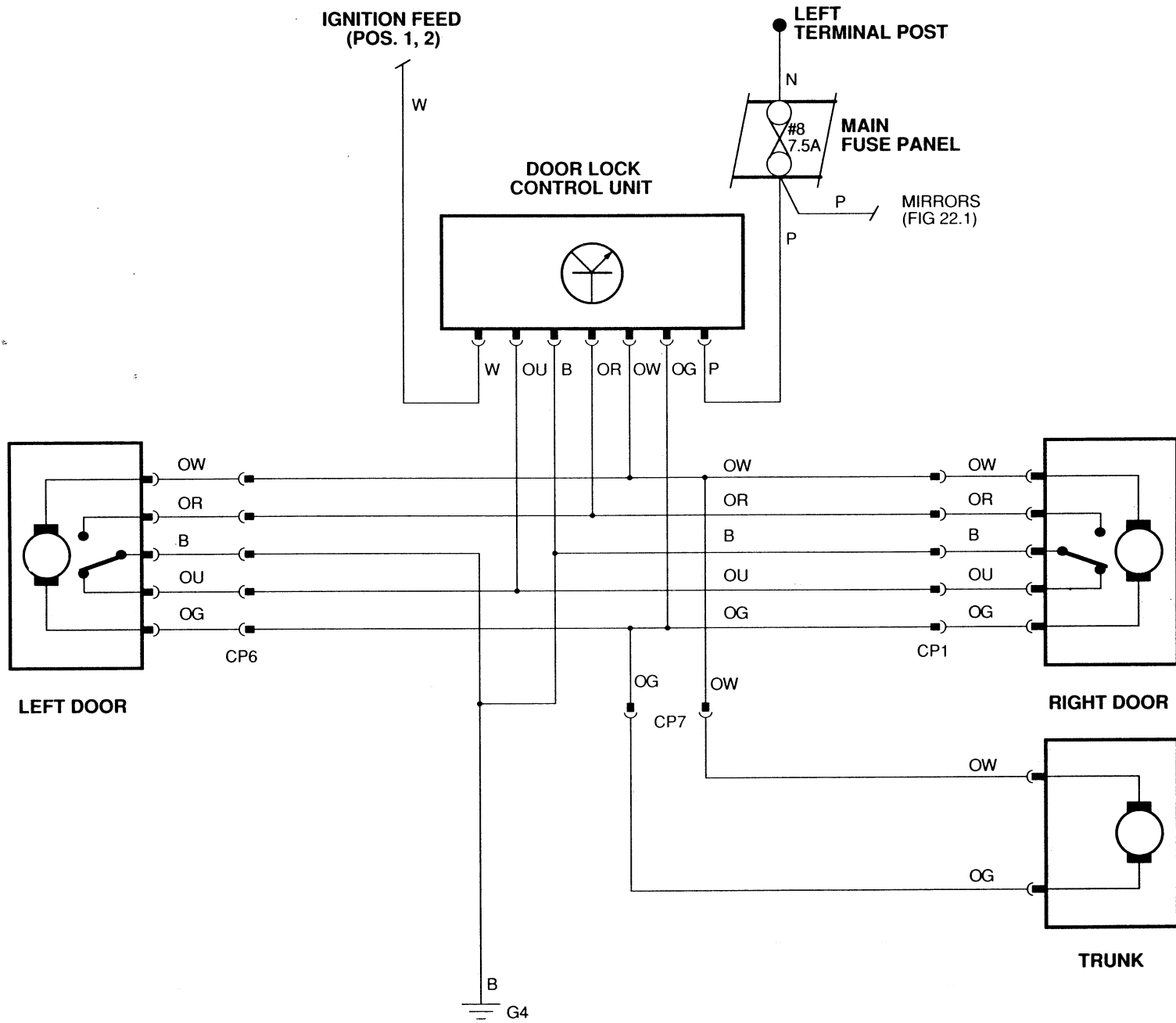


FIG 20.3

POWER WINDOWS

XJ-S
1989 MY



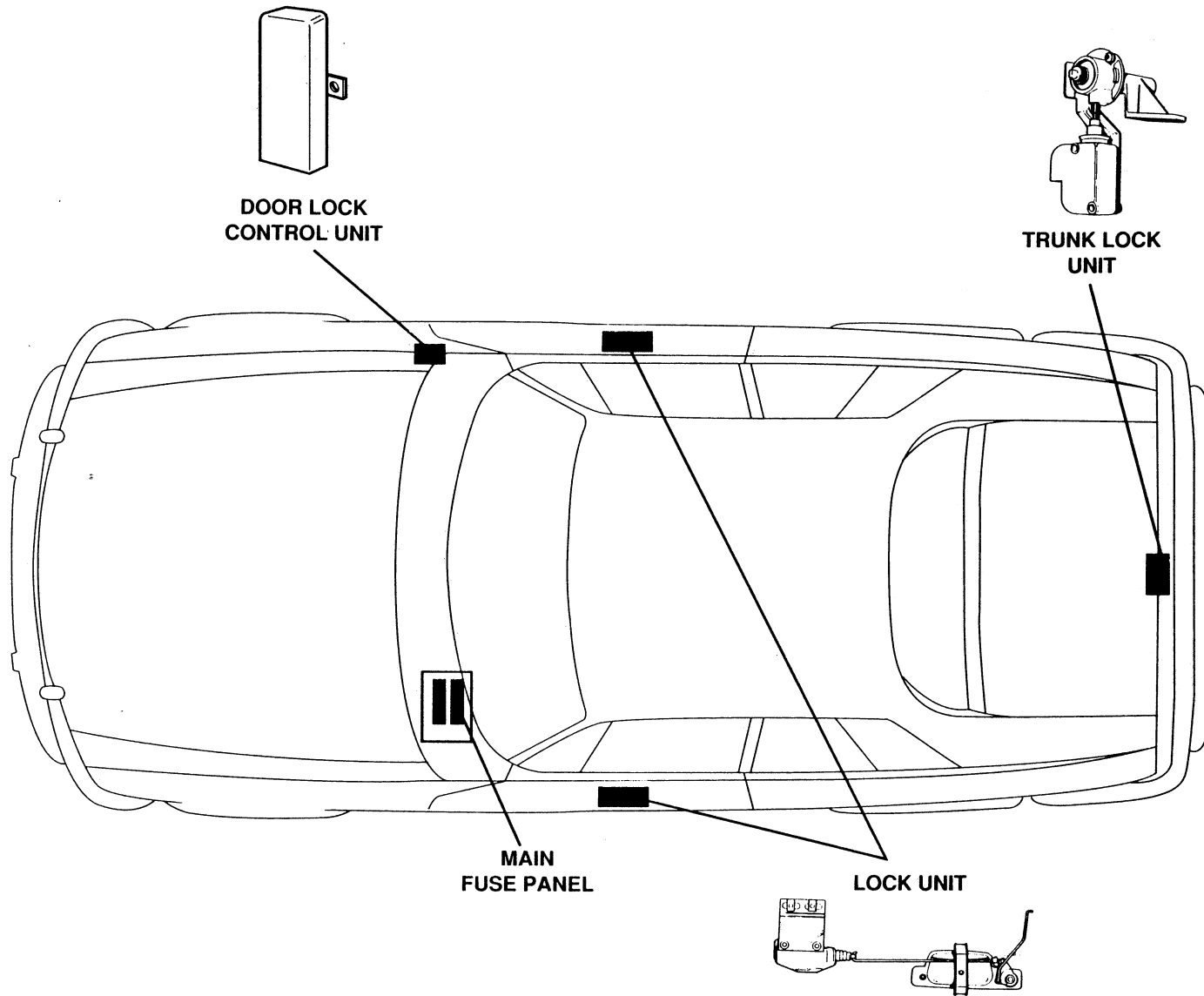
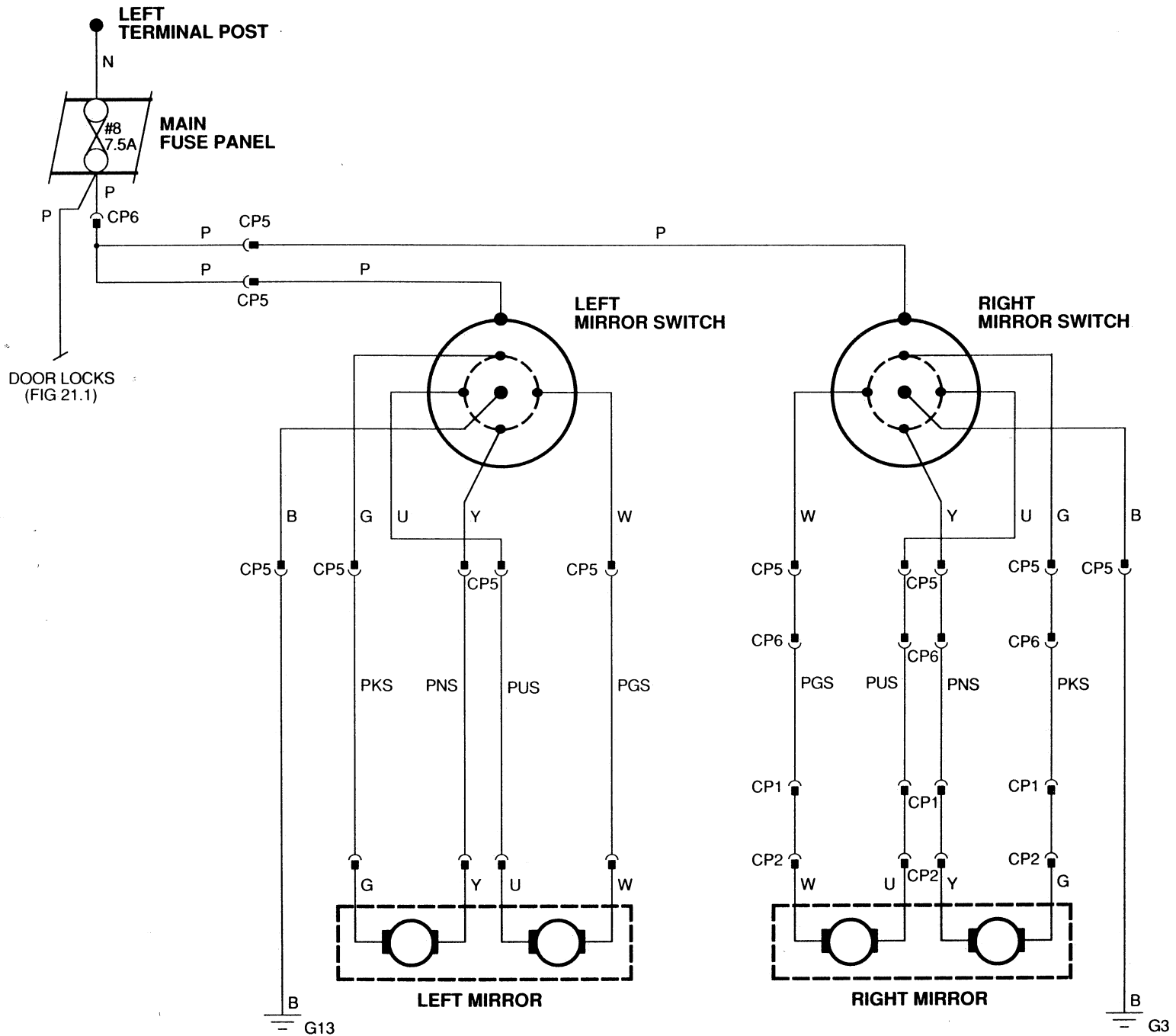


FIG 21.2

DOOR LOCKS

XJ-S
1989 MY



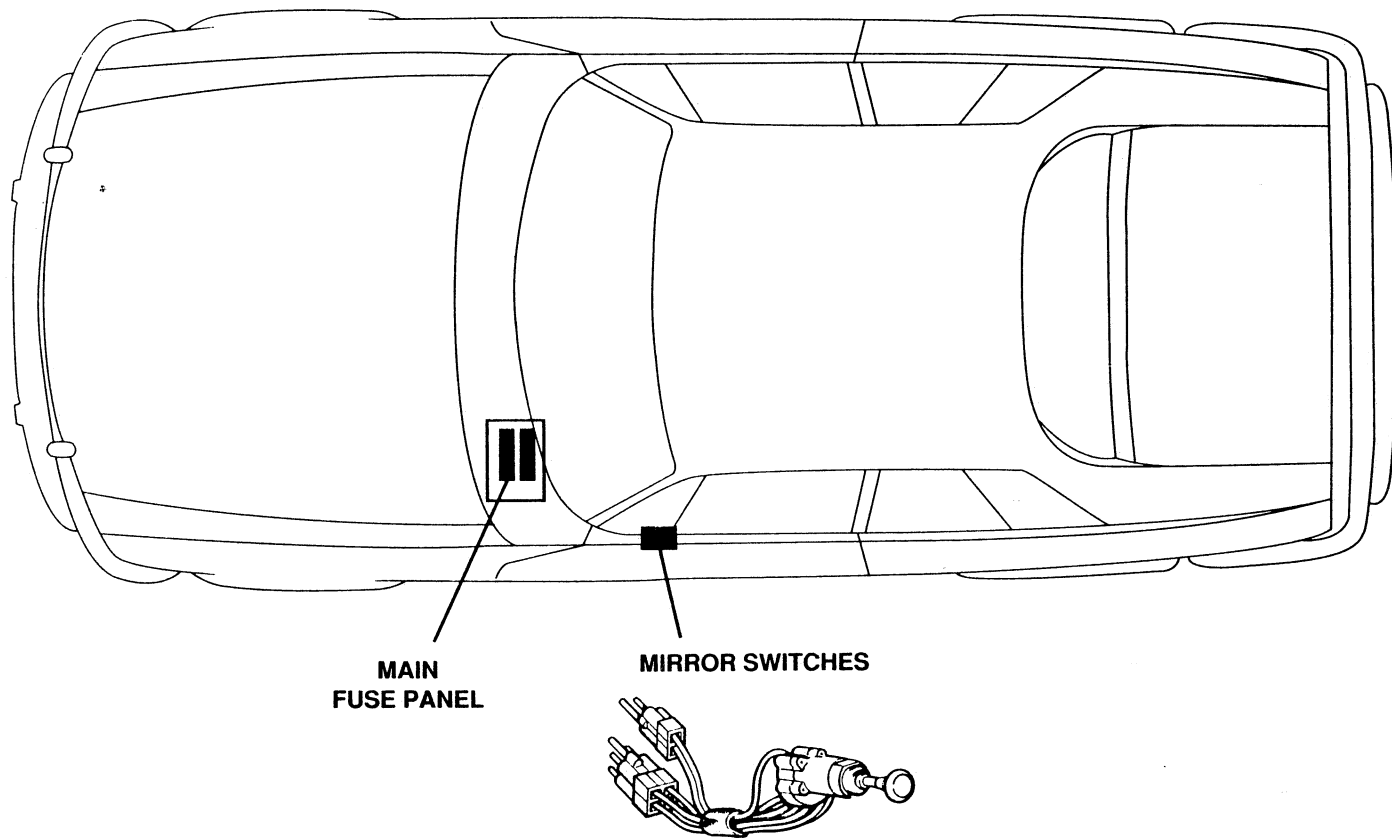


FIG 22.2

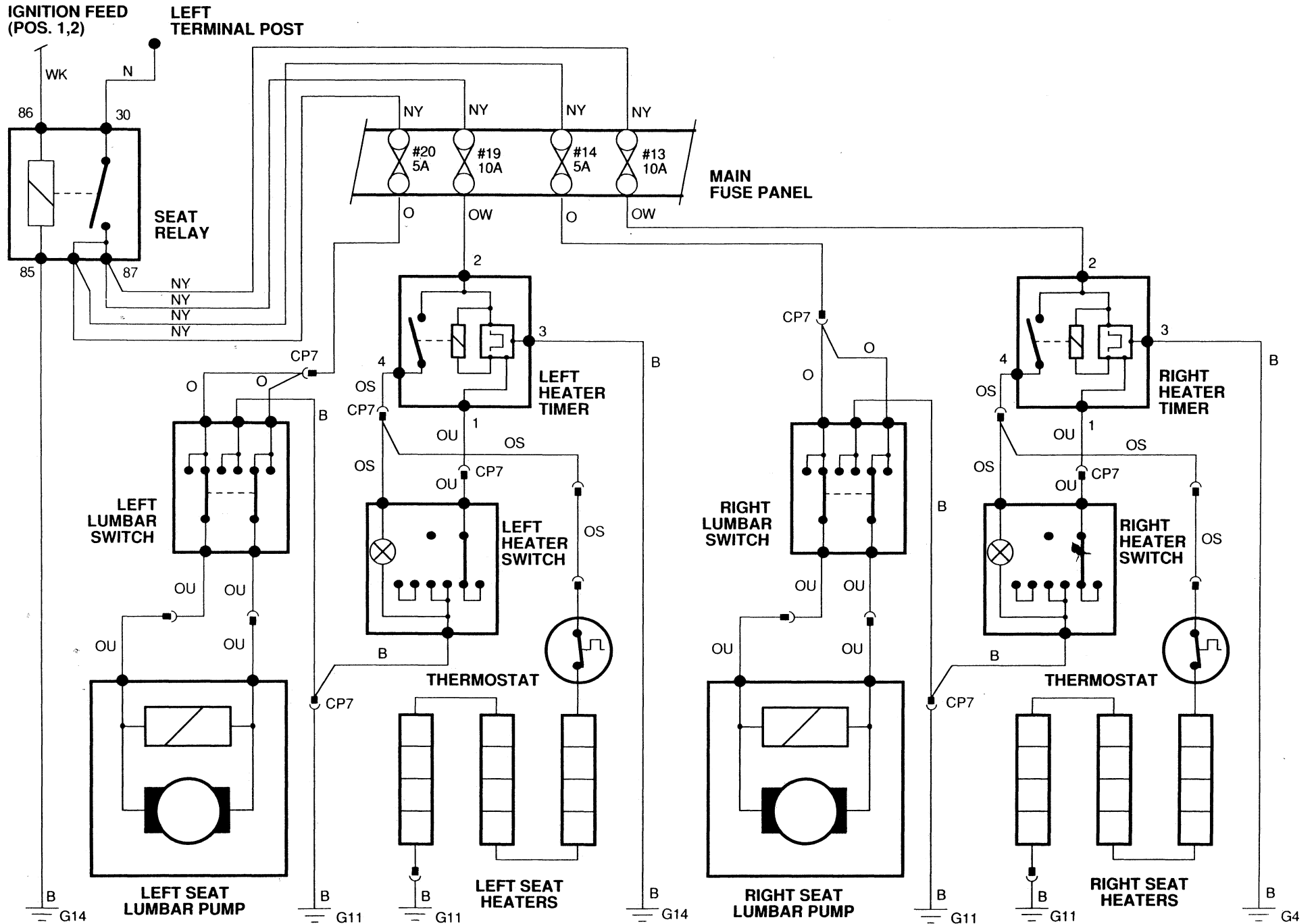
POWER MIRRORS

XJ-S
1989 MY

FIG 23.1

HEATED SEATS; POWER LUMBAR SUPPORTS

XJ-S
1989 MY



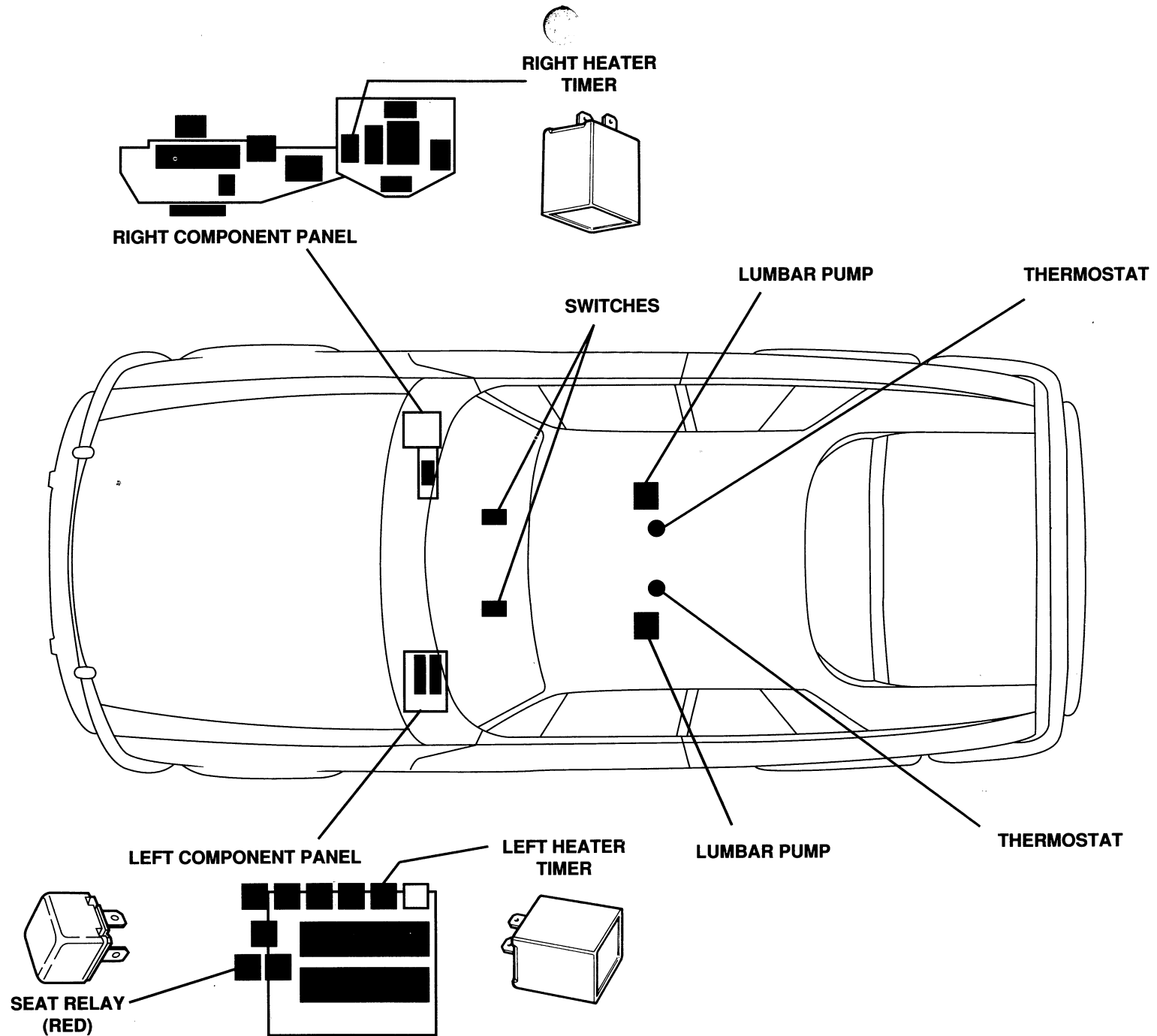
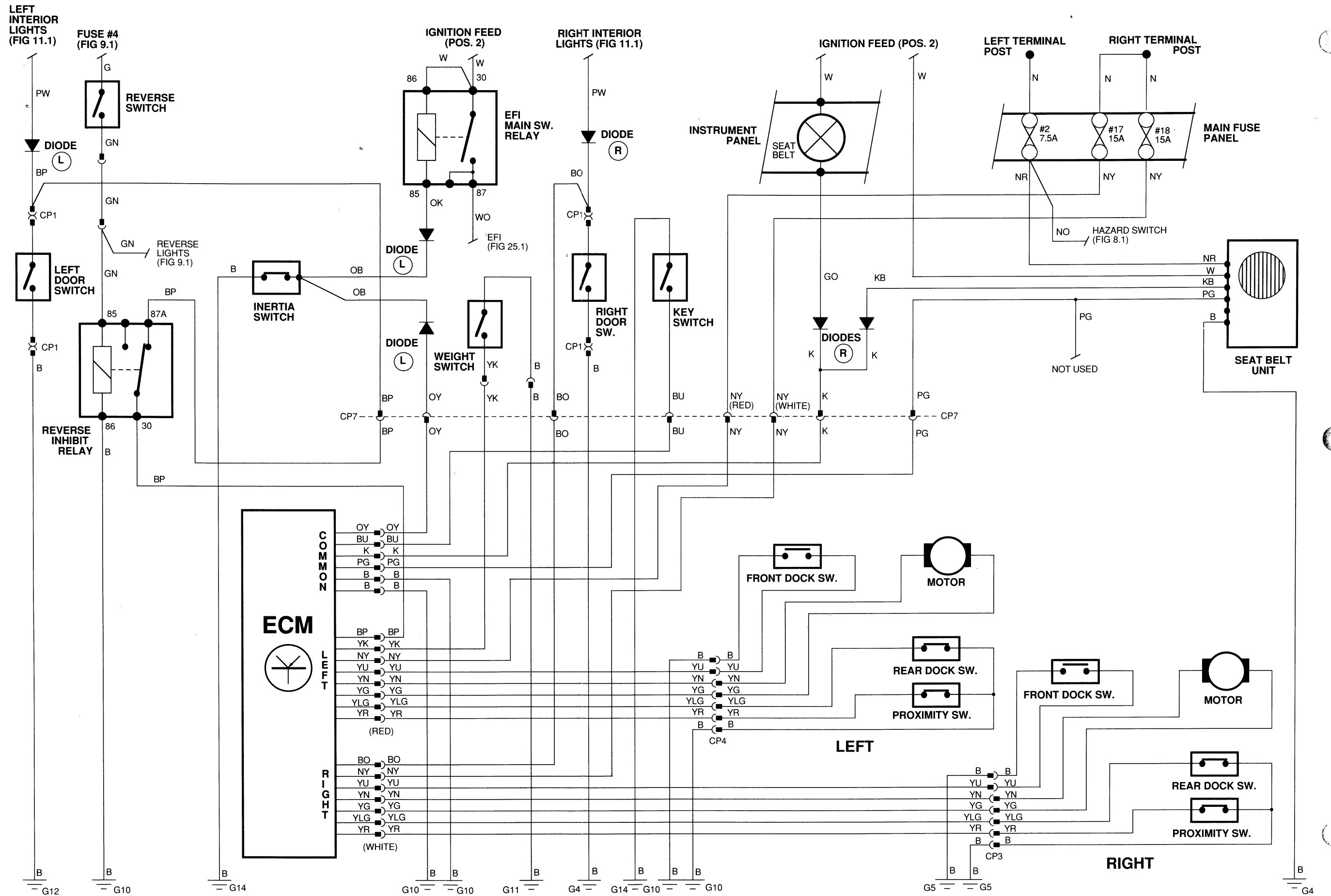
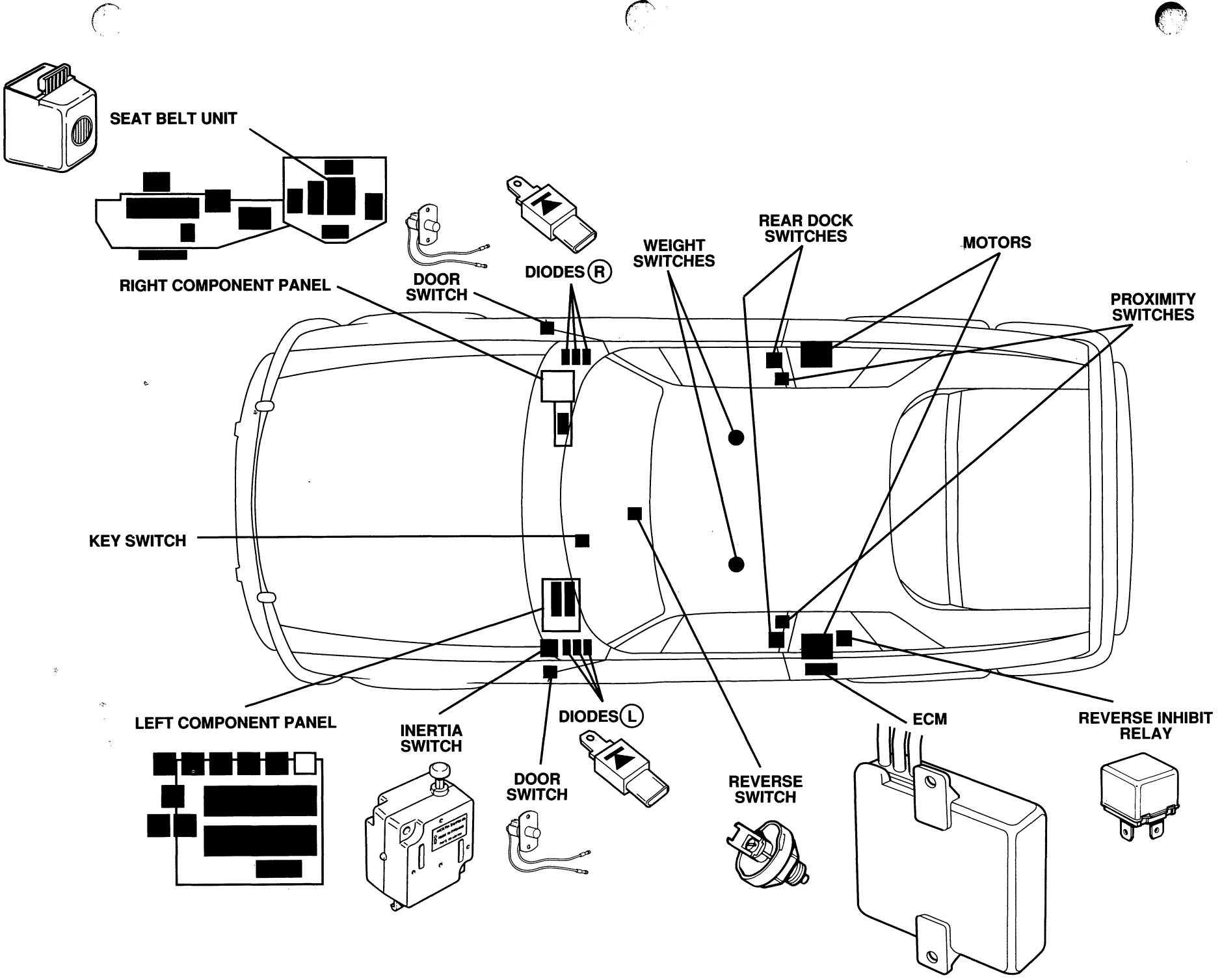


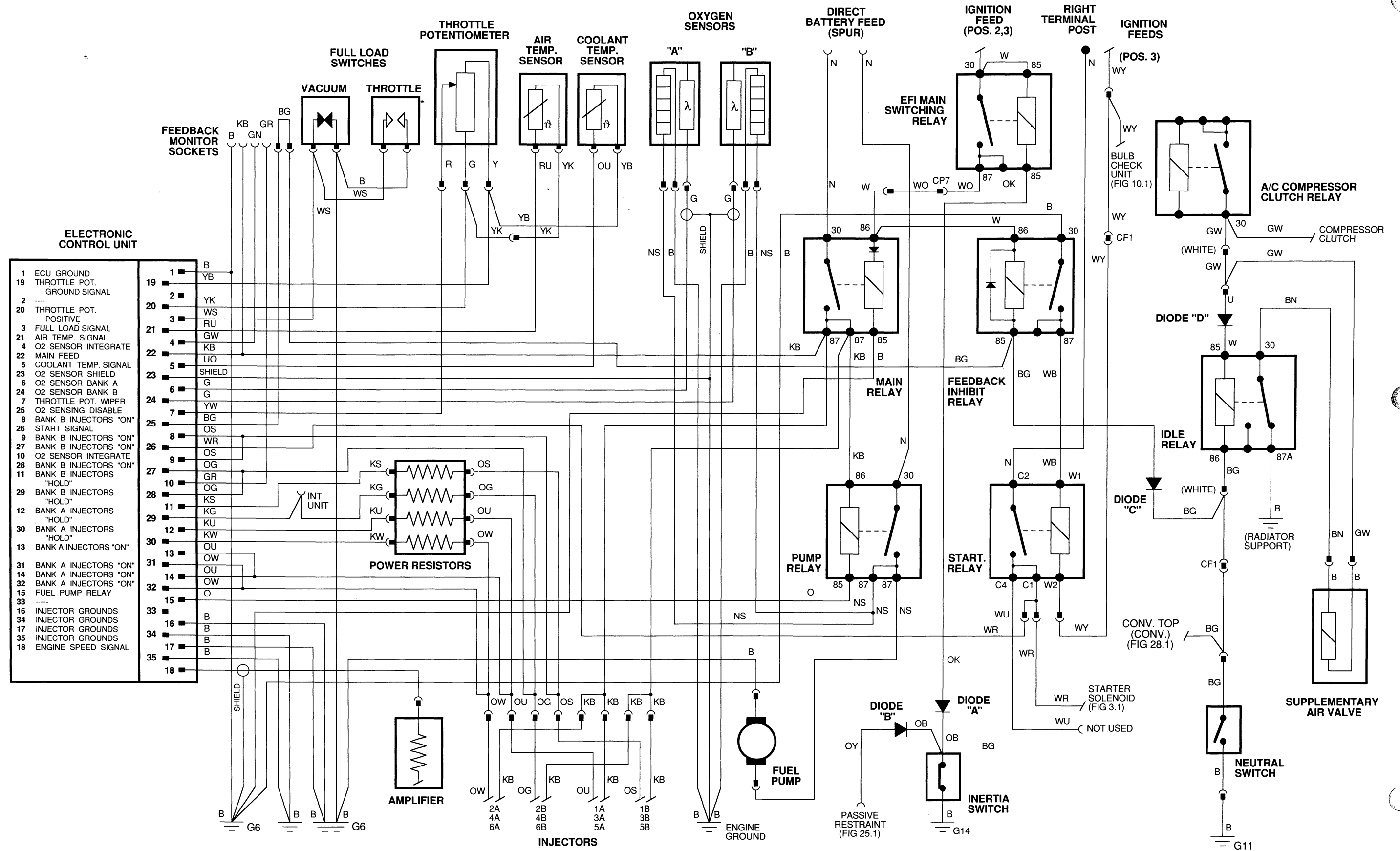
FIG 23.2

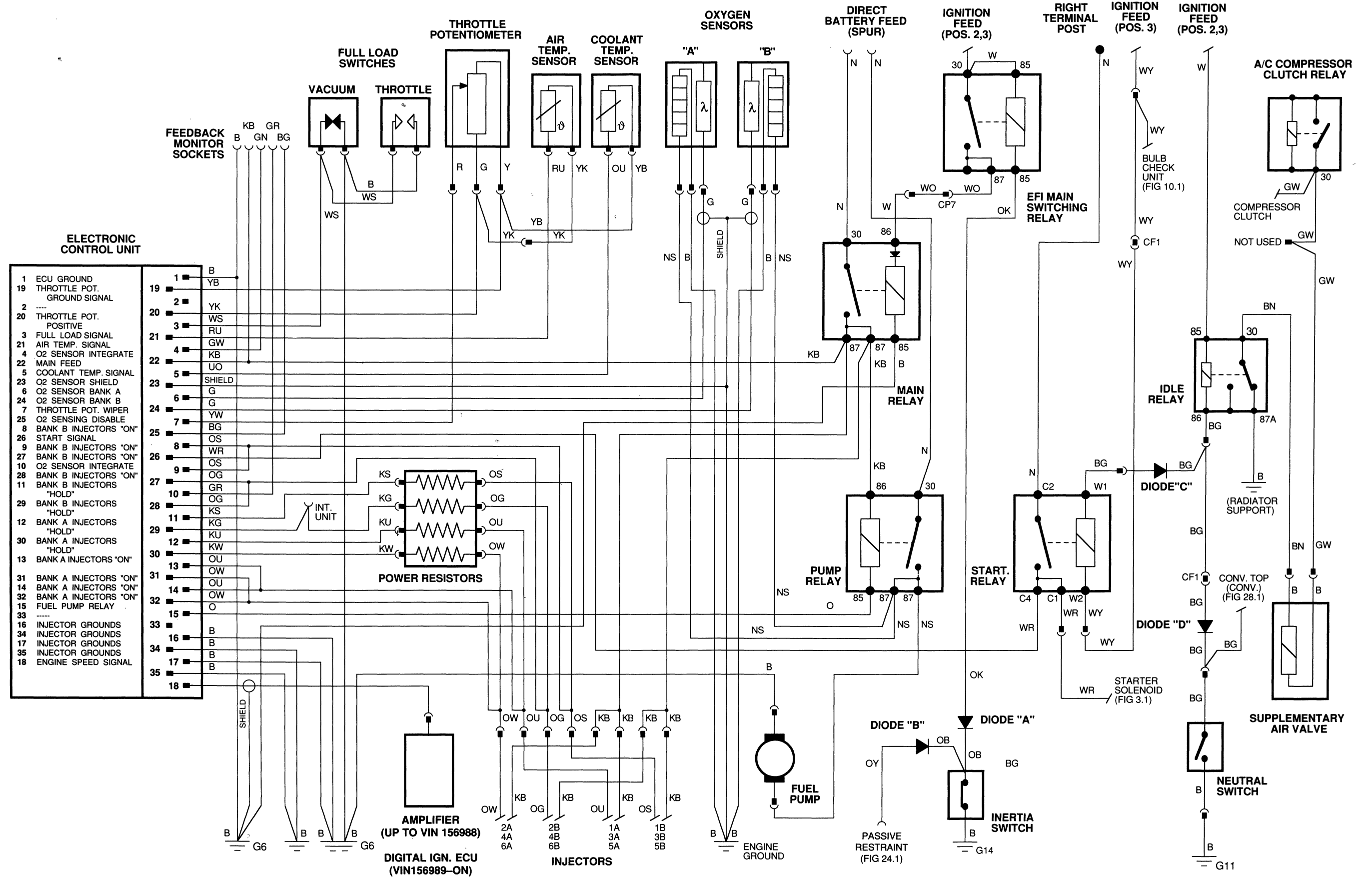
HEATED SEATS; POWER LUMBAR SUPPORTS

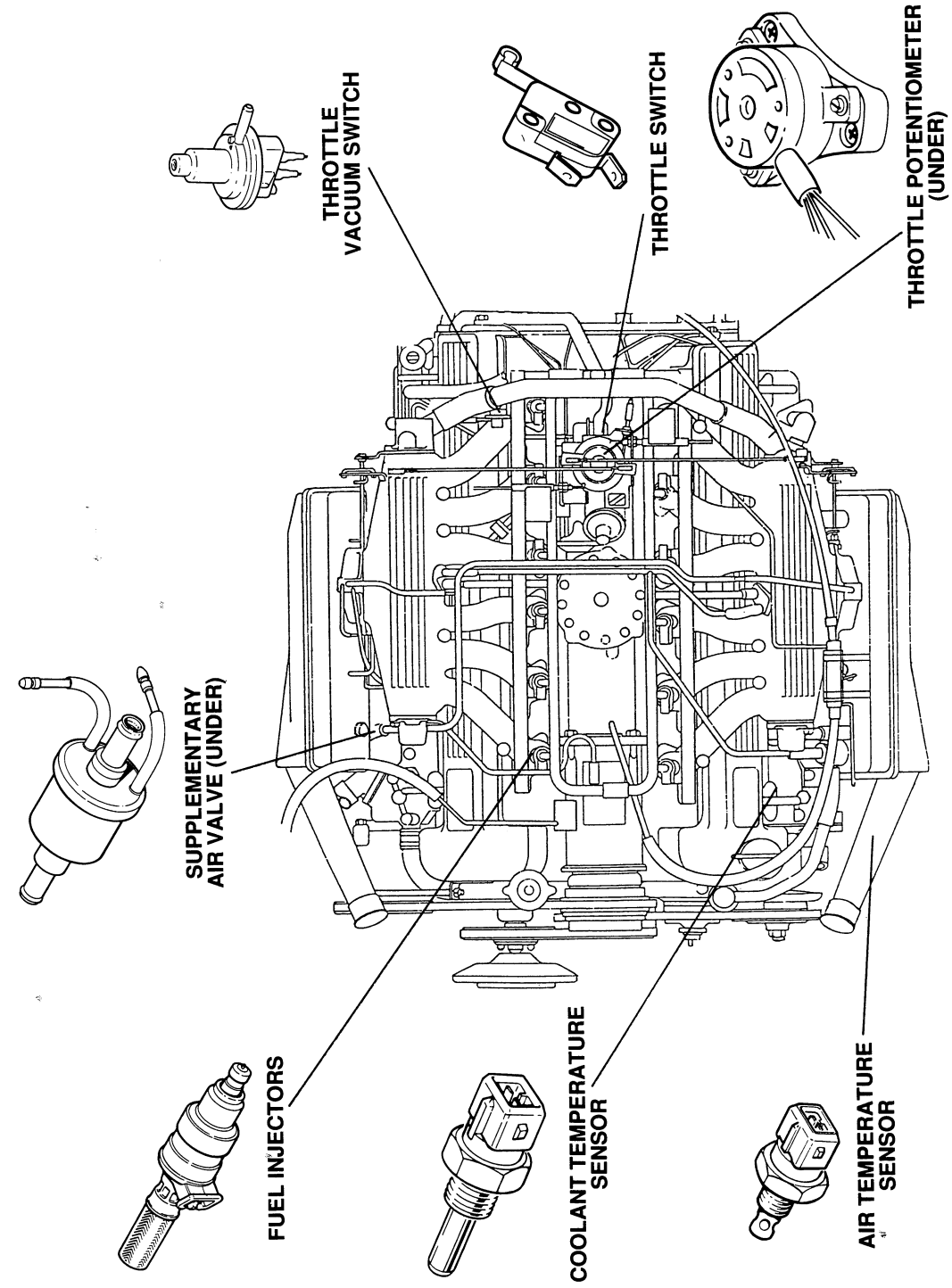
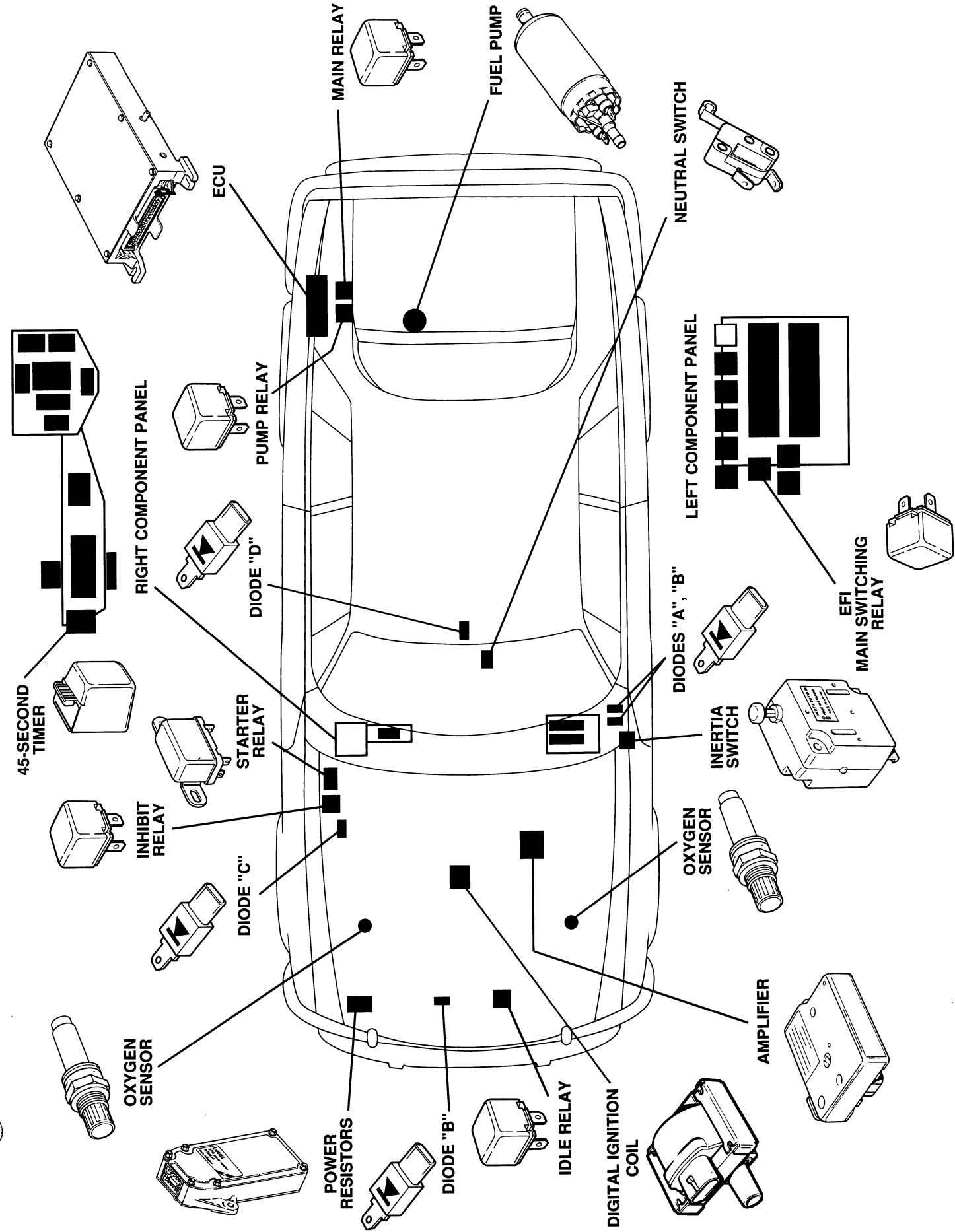
XJ-S
1989 MY

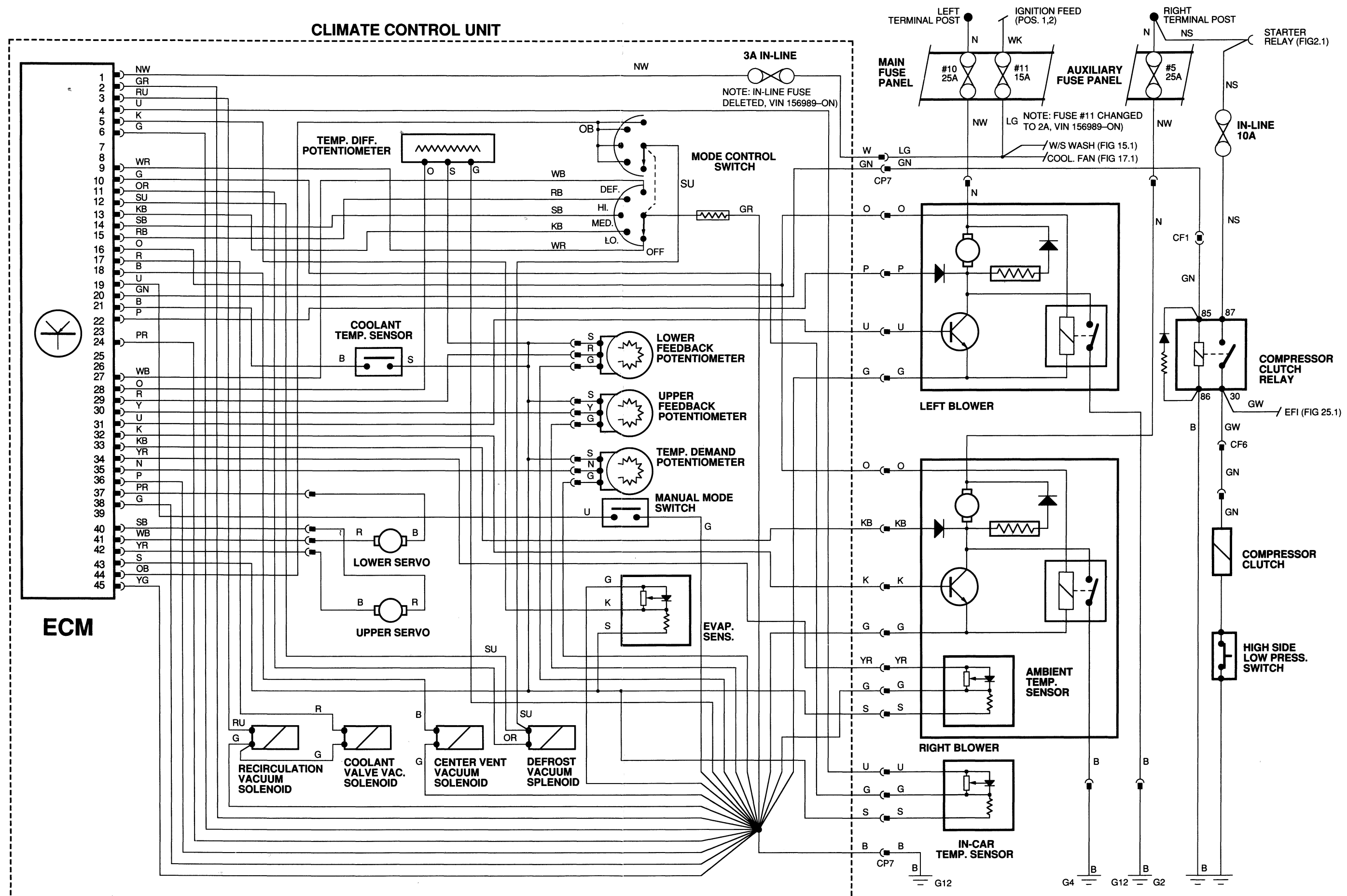












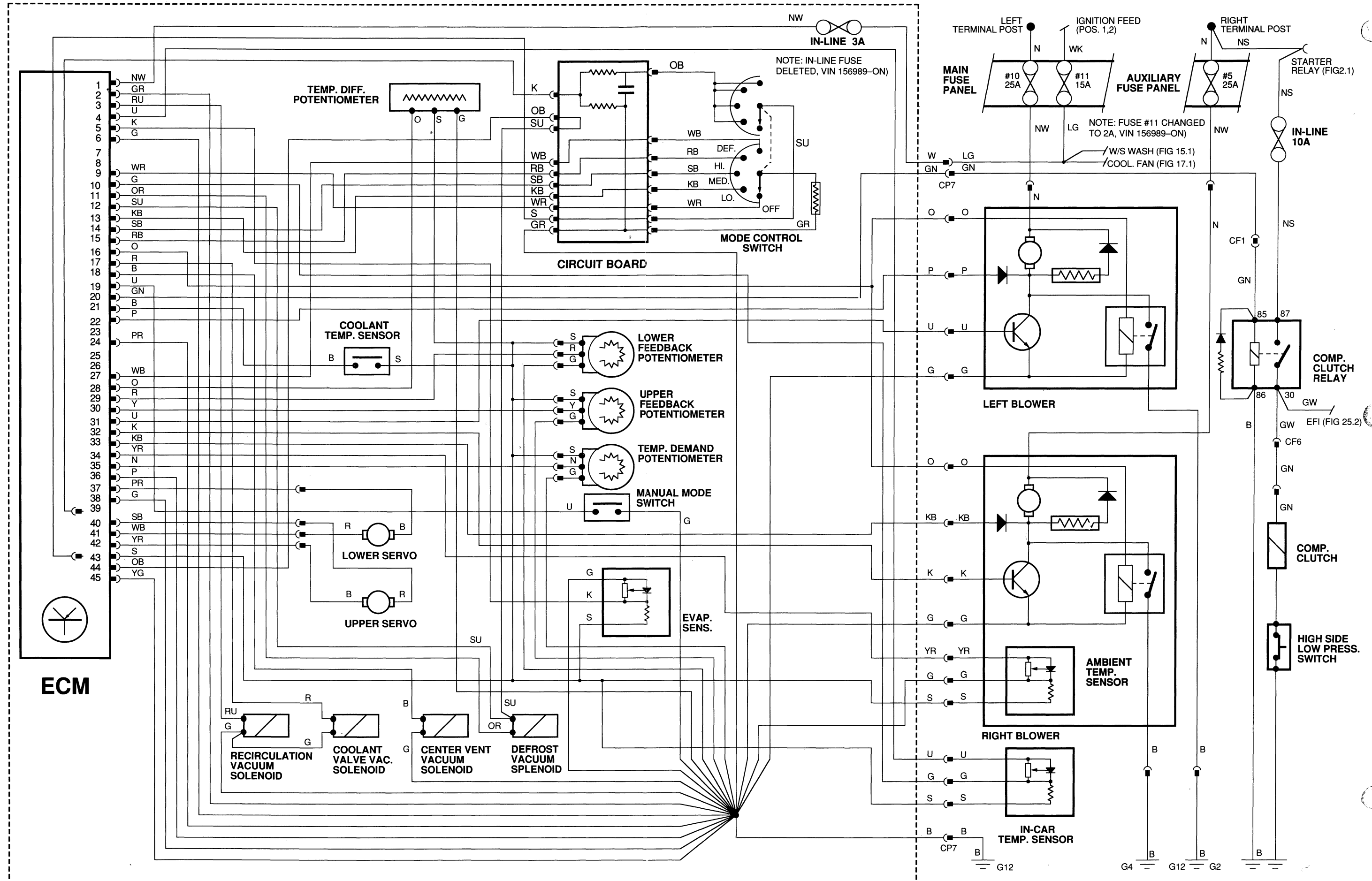
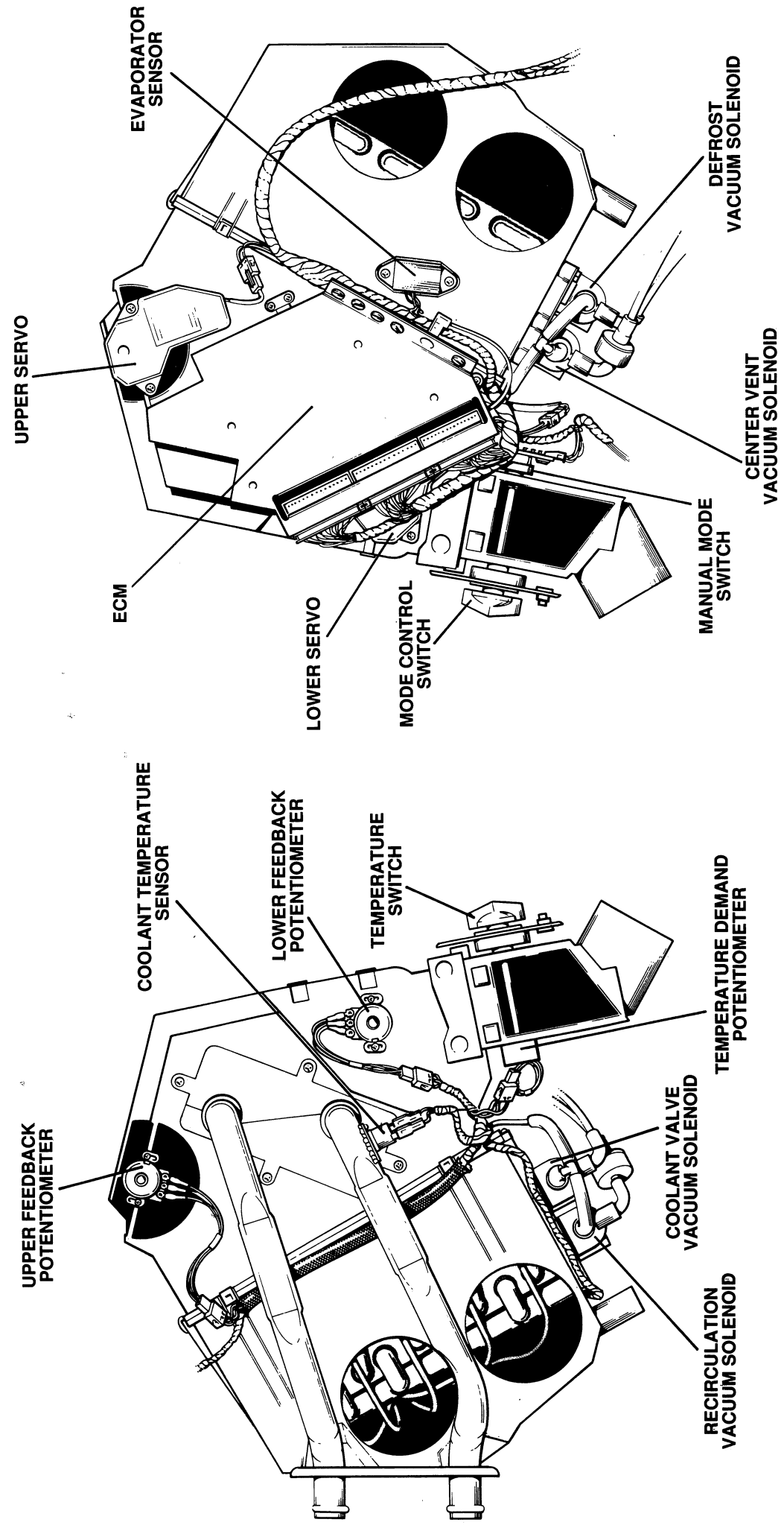
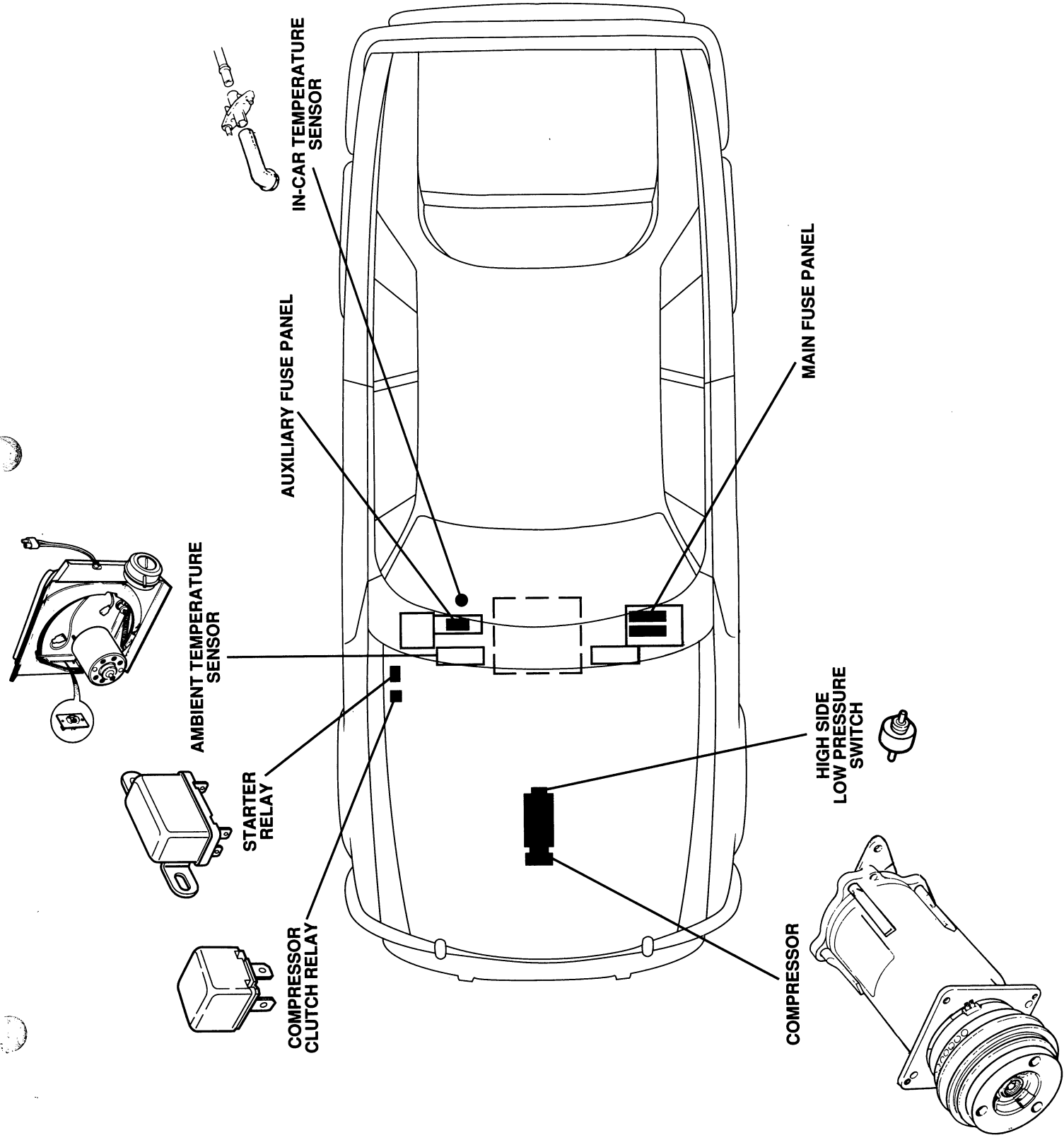


FIG 26.3

CLIMATE CONTROL

XJ-S
1989 MY



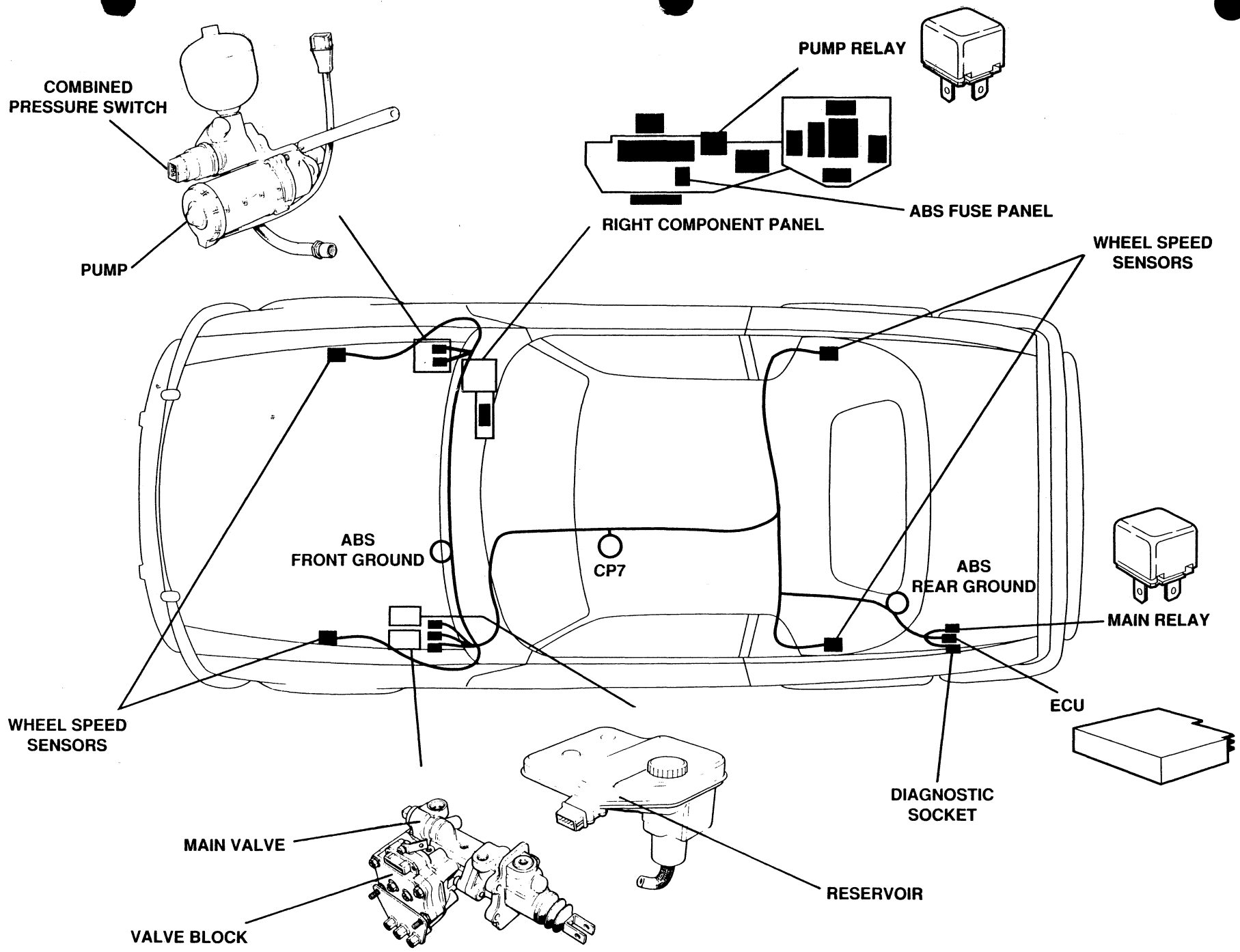
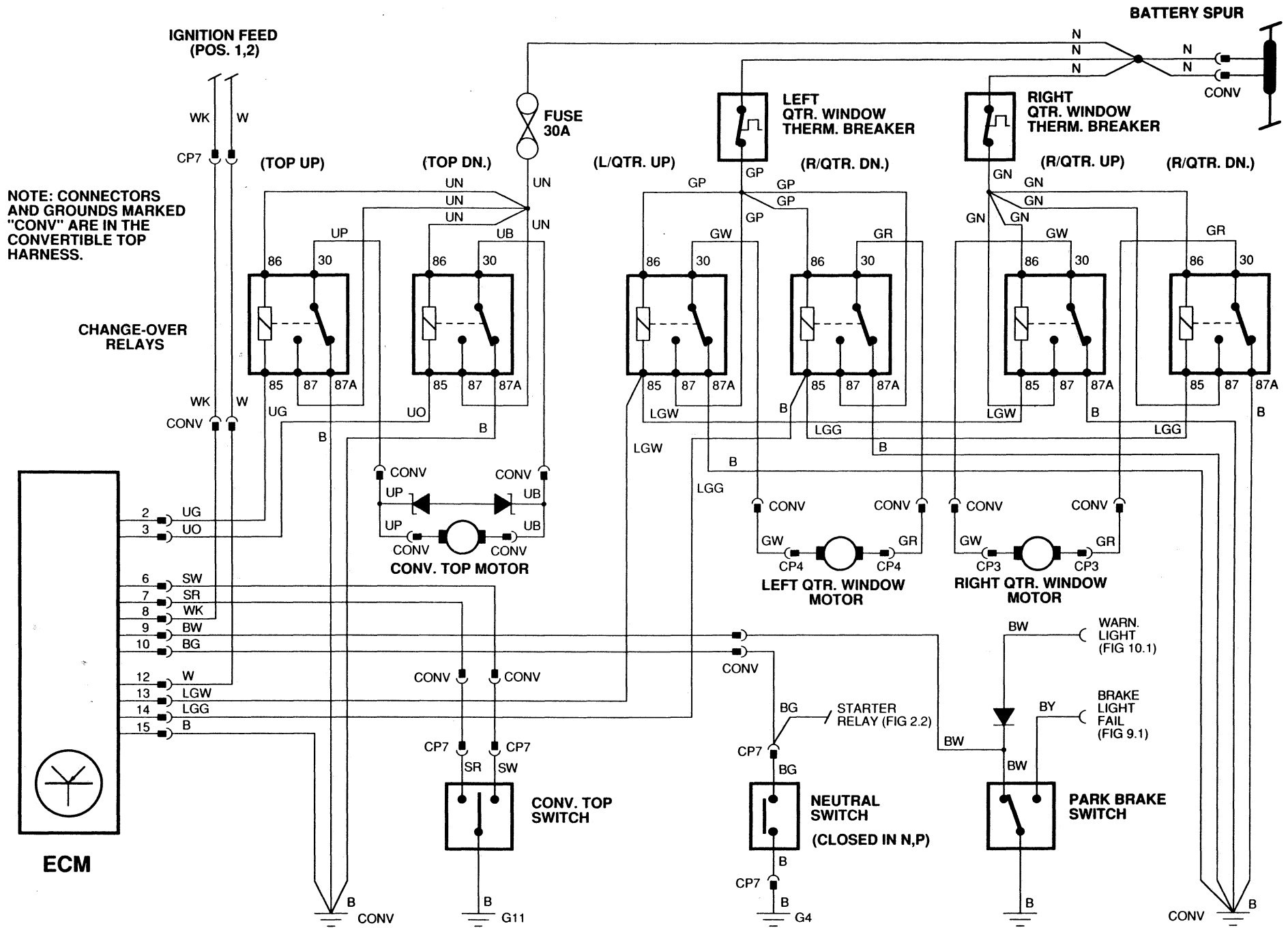


FIG 27.2

ANTI-LOCK BRAKING



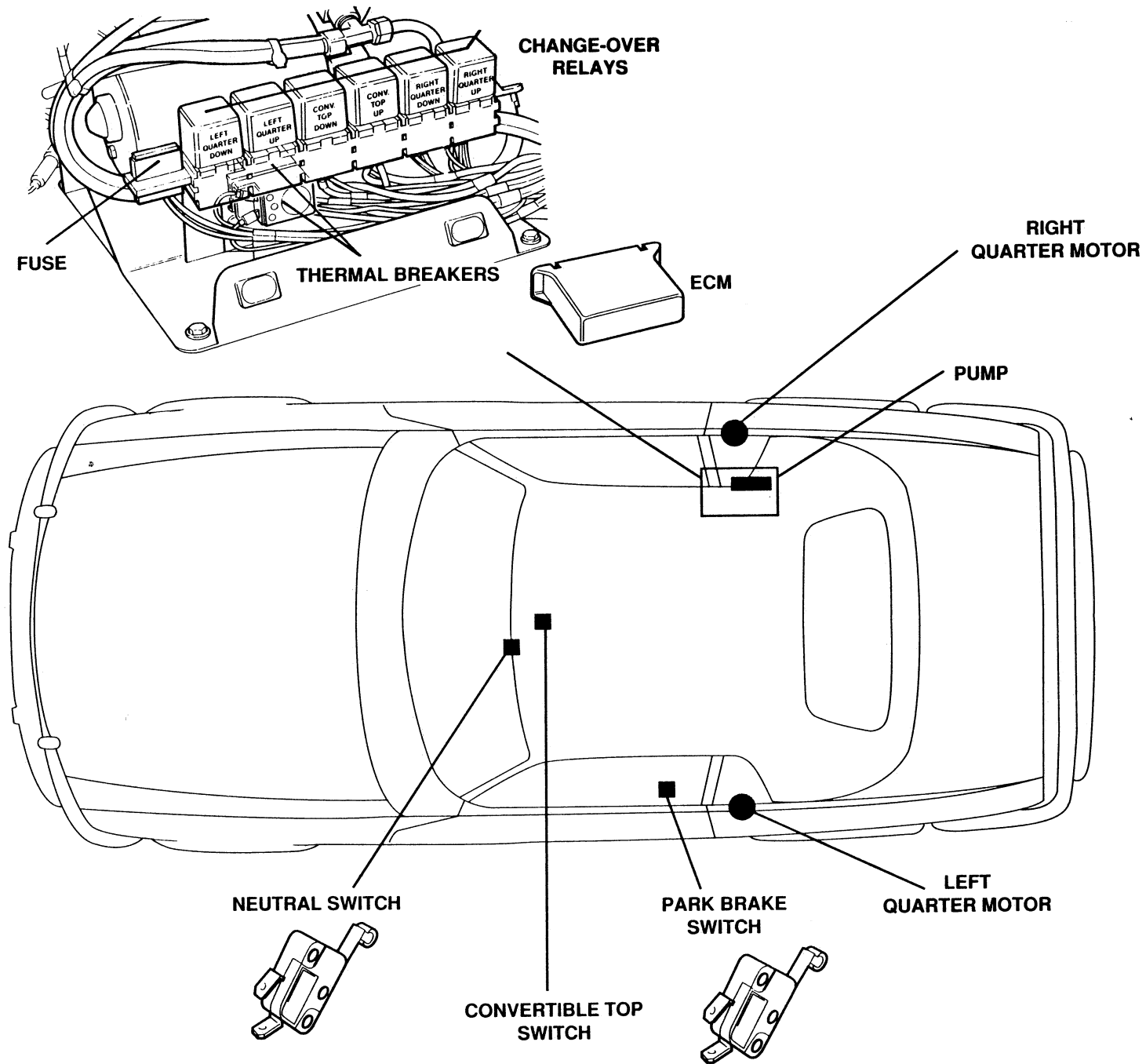
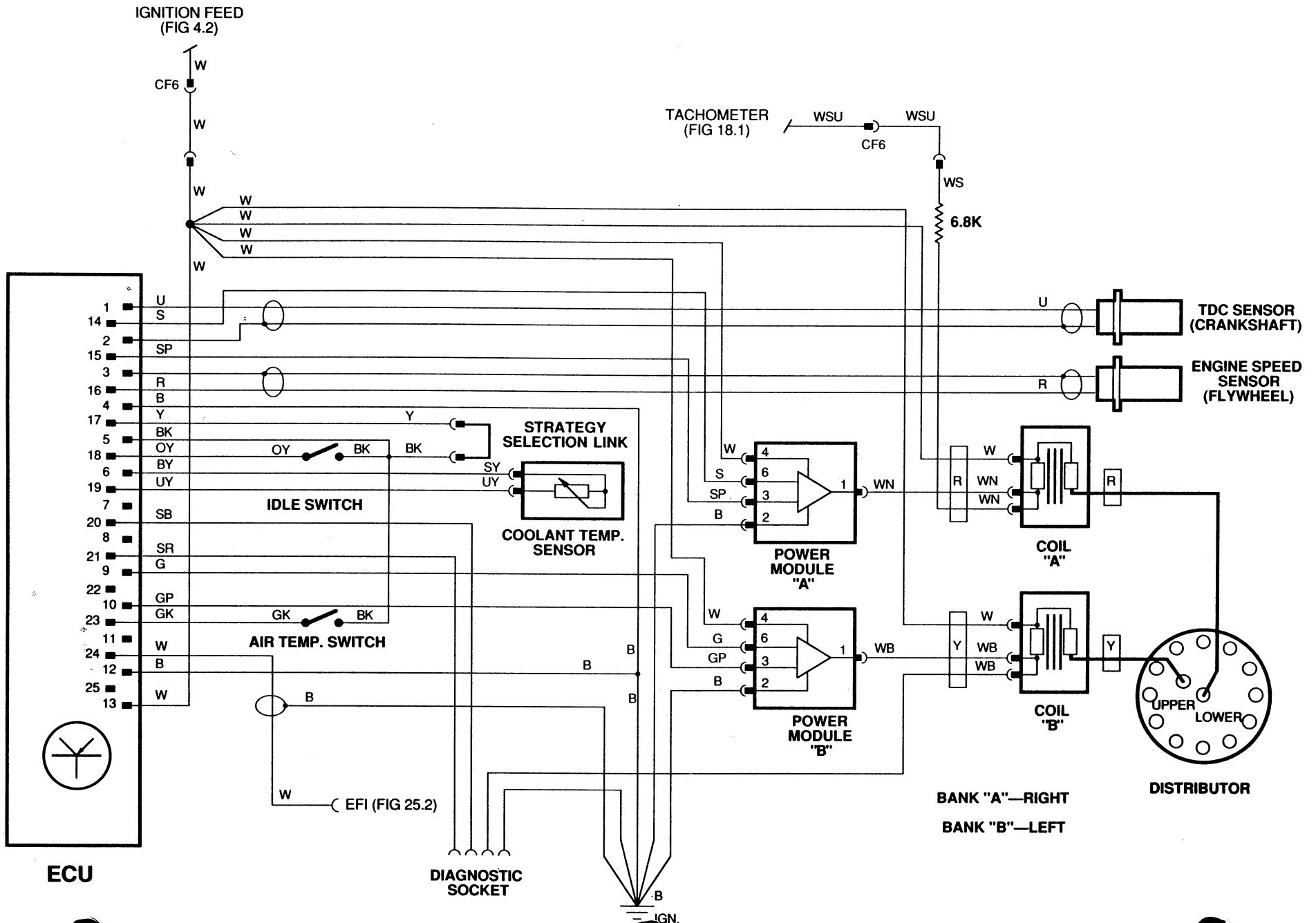


FIG 28.2

CONVERTIBLE TOP (CONV.)

XJ-S
1989 MY



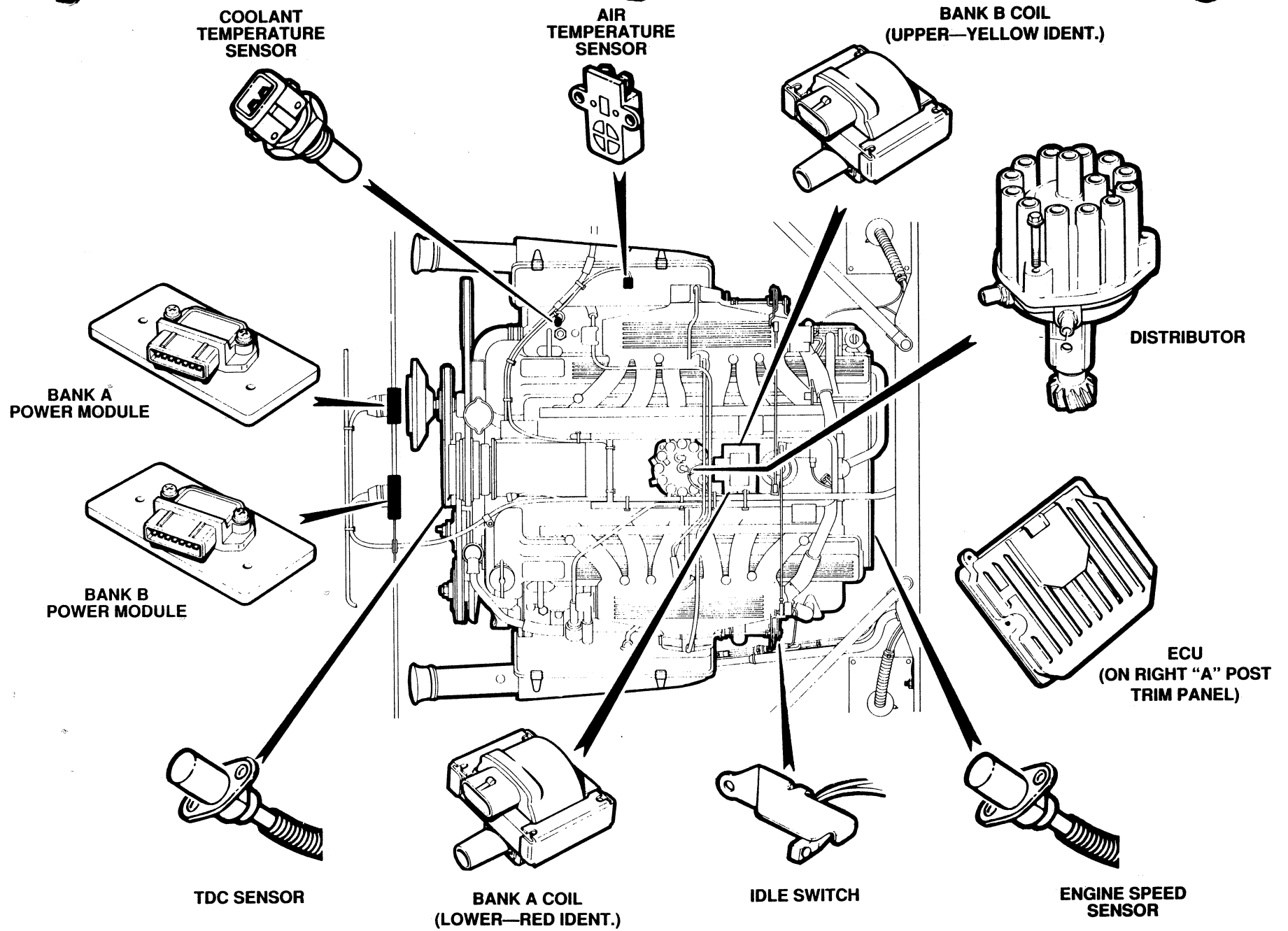


FIG 29.2

DIGITAL IGNITION (VIN 156989-ON)

XJ-S
1989 MY