

Jaguar TH400 transmission mount explained:

This is what I have worked out over 43 years with Jaguar, and I am in Australia, and we talk strange (apparently), and then there is my very warped sense of humour, take it or leave it.

This spring loaded arrangement used for the rear transmission mounting has confused many, over many years, and I was also in that mix.

The Spare Parts book diagram, my usual source of assembly correctness, is as vague as the Service manuals I have referenced over the years.

The main issue here was that someone somewhere has had this apart, and lost bits, and put it back as best they remember, which is usually wrong. Then there are the ones that always do things by “shortcut”, and this is not going to work here.

Bolted to the extension housing of the transmission is a “pin assembly”, and that pin is “stepped” for a reason, which will become clearer further in the writings.

Also there was a service bulletin issued a long time ago to place 2 washers, 1 for each bolt that secure this “pin” to the transmission housing. These were as a spacer to raise the position of the housing by about 2mm (the thickness of each washer), so the front universal joint ceased its habitual clobbering of a tin vertical plate that is part of the lower plate assembly, under certain conditions, such as traversing “speed humps”, when the “downward movement” of the transmission allows this contact to occur, or under hard acceleration usually from a standstill.

When dismantling this mount, some care is required.

- 1) Undo the $\frac{3}{4}$ " nut, nothing should fall out.
- 2) If you still have the "collision bracket" fitted, then undo the bolts and nuts required to remove the lower plate of this arrangement.
- 3) At this point a washer (welded double) and a spacer sleeve will fall out, so be prepared for it.
- 3) Up inside that "cotton reel" bush, there should be a round shouldered washer, IF YOU ARE LUCKY, and most are not lucky so this washer is missing. To explain that washer. It is a $\frac{1}{2}$ " ID washer, which suits the pin, and the OD is a "firm slide fit" to the ID of that rubber mounting bush. It is NOT available as a spare part. I use a spring washer of what is commonly known as a "flat section spring washer", and I have NO issues finding them at any bolt/nut/washer supplier.
- 4) Now comes the fun, getting that mount frame out of the car. Remove both exhaust triangle clamps at the front, and allow the system to hang down, and the exhaust heat shields can be removed, thus giving access to the 4 bolts that secure that frame to the car.

WARNING, PLEASE TAKE NOTE OR PAIN WILL HAPPEN.

- 5) Jack up the transmission/engine assembly as far as it will go up into the tunnel, don't be stupid with jacking, just get it up there. I place a piece of wood across the trans pan and then when raised I place a safety stand to assist the jack to keep it safely in that raised position. Positioning of the

jack so a safety stand can fit is your brain work, but I usually jack at the rear of the trans pan, and place the safety stand towards the front, a bit fiddly, but the jack bleeding down is NOT going to be fun. This jacking releases SOME of the tension on that spring, but it still packs a punch.

- 6) Slowly and carefully undo the 4 bolts securing the frame to the car. I place my floor jack under that frame, with the plate removed from the jack, the pin of the transmission simply protrudes through that hole. As the bolts are removed there are spacers in there, so take note (or photos) as your memory is NOT that good, trust me. Lower the jack CAREFULLY and the rest of the punch in that spring will release and the assembly will fall out. Watch out as it is on the heavy/awkward side, and will hurt.

Replace that “cotton reel” bush. I use Poly now, as they are not dissolved with oil and grease and stuff, and the bush in my XJ-S is 16 years and still as fitted. Replace the rubber spring seat (no poly available for this part).

Check for the 2 washers between the pin housing and the transmission, if they are not fitted, I suggest fitting them, nothing special, just a flat washer about 1.5 – 2mm thick.

- 7) Refit the frame to the car, by using that floor jack again, and with extreme care, that spring is a fickle thing at best, and refit the spacers you “noted”, and the 4 bolts. Secure these bolts suitably, NOT TIGHT just yet. Raise the transmission again and remove that safety stand, and lower the assembly. Look now at the centre pins orientation inside the cotton reel, it MUST be central, and near enough is NOT good enough, so using a large screwdriver move that frame around on its slotted holes until that is achieved. Once central, secure those 4 bolts.

- 8) Slide that rounded washer (if you have it) or the spring washer over the pin, and push it inside using the spacer sleeve. Slide that spacer sleeve into place, followed by the double welded washer at its base, then the lower plate of the “collision bracket” followed by the $\frac{3}{4}$ ” nyloc nut.

- 9) Refit the heat shields and exhausts and lower the car, all done.

The BW65/66 mounting is similar to a point, but they have 2 spacers on their pin, with the round shouldered washer between the 2 spacers. The pin on these is threaded into the transmission casing in lieu of the plate arrangement the TH400 has.

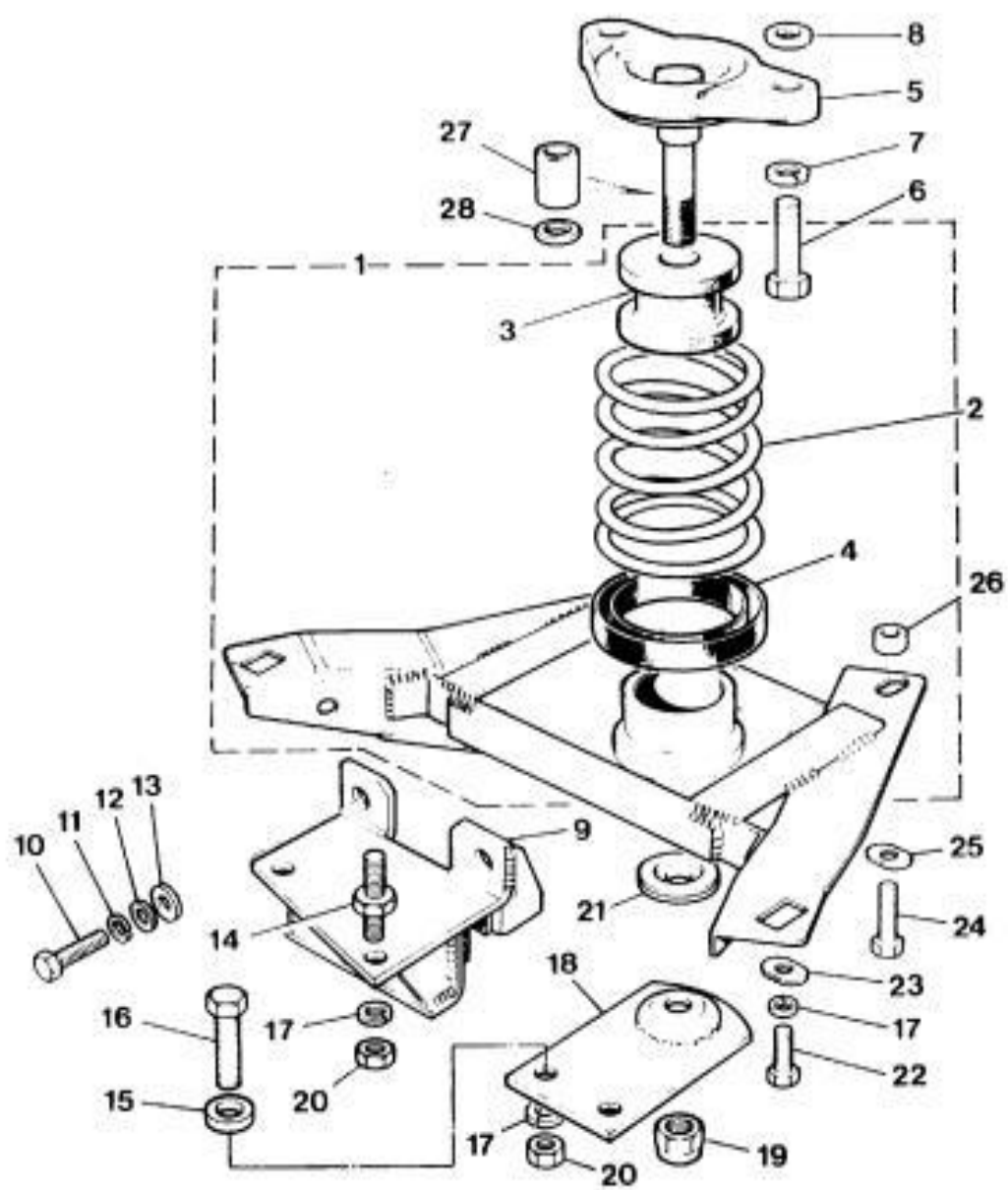

MB1050B