

Parts:

D1	Diode	1N4148
Z1	Zener diode	8V2
Z2	Zener diode	BZX85C (36V)
T1	Transistor	BC547
T2	Transistor	BC547
T3	Transistor	BC337
T4	Transistor	TIP41A
R1	Resistor	10 kOhm
R2	Resistor	47 kOhm
R3	Resistor	2k2 Ohm
R4	Resistor	330 Ohm
R5	Resistor	2.4 MOhm
R6	Resistor	47 kOhm
C1	Condenser	22 μ F/35V
C2	Condenser	22 μ F/35V
C3	Condenser	22 μ F/35V



EFI and emissions control

VIN 133461-ON

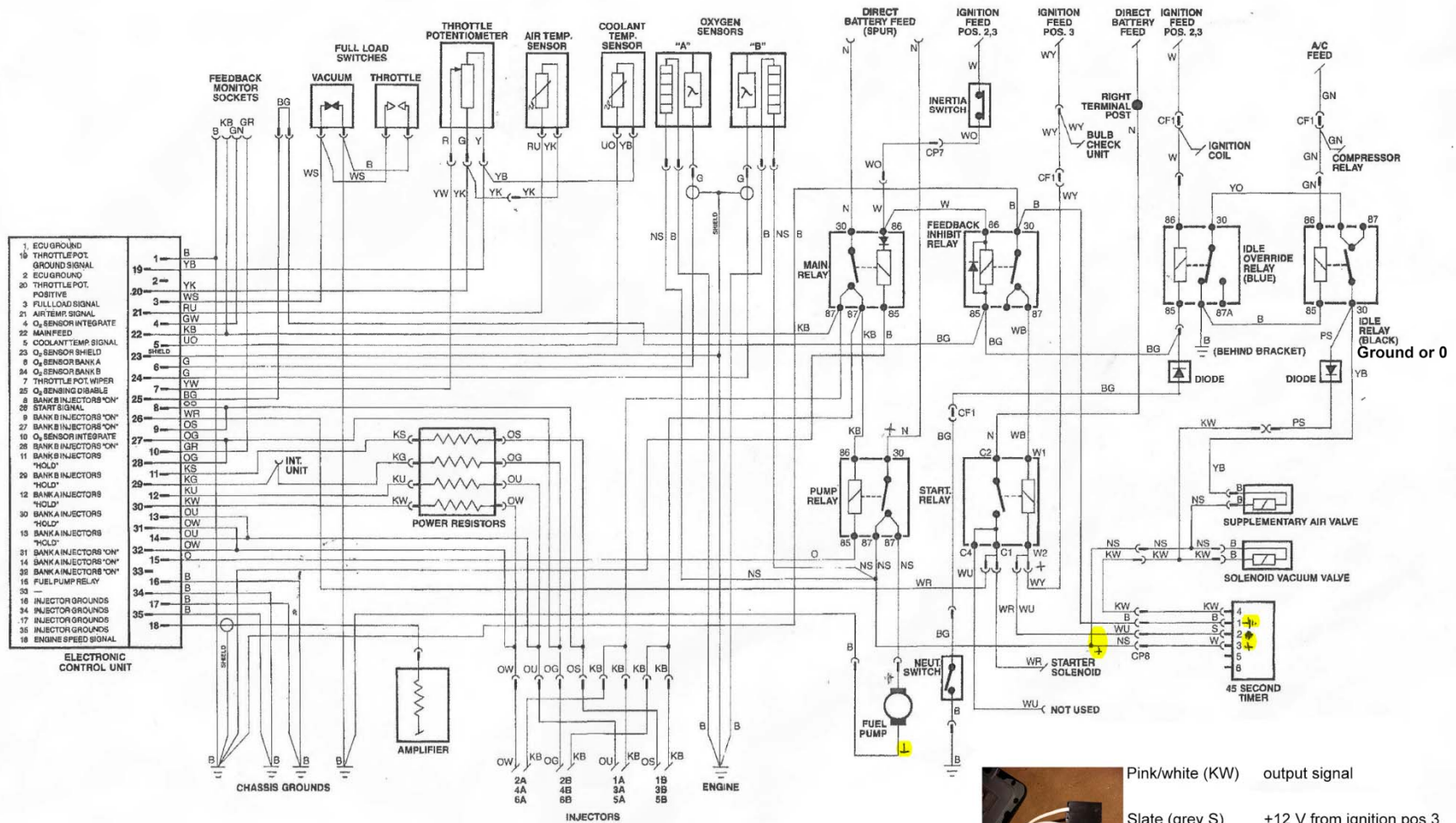

- Pink/white (KW) output signal
- Slate (grey S) +12 V from ignition pos 3
- White (W) +12V from fuel pump
- Black (B) ground