

2

1

ITEM NO.	PART NUMBER	DESCRIPTION	QTY.
1	100000-002	CAP, TIMING COVER PLUG	1
2	100000-003	PLUG, TIMING COVER PLUG	1
3	9464K81	-117 VITON ORING	1
4	92949A267	#10-32X5/8 18-8 BUTTON HEAD SCREW	1

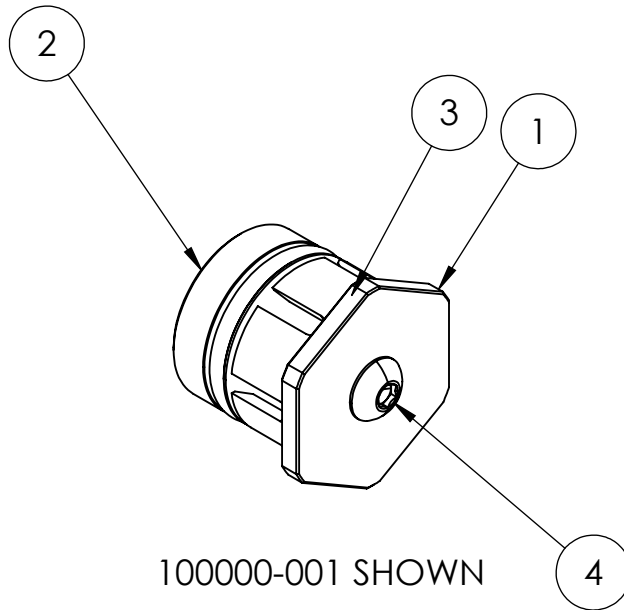

NOTES

1. MACHINE 100000-002 AND 100000-003 FROM ALUMINUM ALLOY, 30KSI MIN YIELD STRENGTH
2. UNLESS OTHERWISE SPECIFIED BREAK EXTERNAL EDGES .002-.020 INTERNAL CORNERS R.005-.020
3. FITS BORE DIA 0.997-1.001

UNLESS OTHERWISE SPECIFIED:		NAME	DATE	TITLE: TIMING COVER PLUG		
DIMENSIONS ARE IN INCHES		DRAWN				
TOLERANCES:		CHECKED				
ANGULAR: ± 5		ENG APPR.				
TWO PLACE DECIMAL ±.010		MFG APPR.				
THREE PLACE DECIMAL ±.001		Q.A.		SIZE	DWG. NO.	REV
INTERPRET GEOMETRIC TOLERANCING PER: Y14.5-2018		COMMENTS:		A	100000	A
MATERIAL				SCALE: 1:1	WEIGHT:	SHEET 1 OF 3
FINISH						
63 RMS MAX						
DO NOT SCALE DRAWING						

2

1

B

B

A

A

2

1

B

B

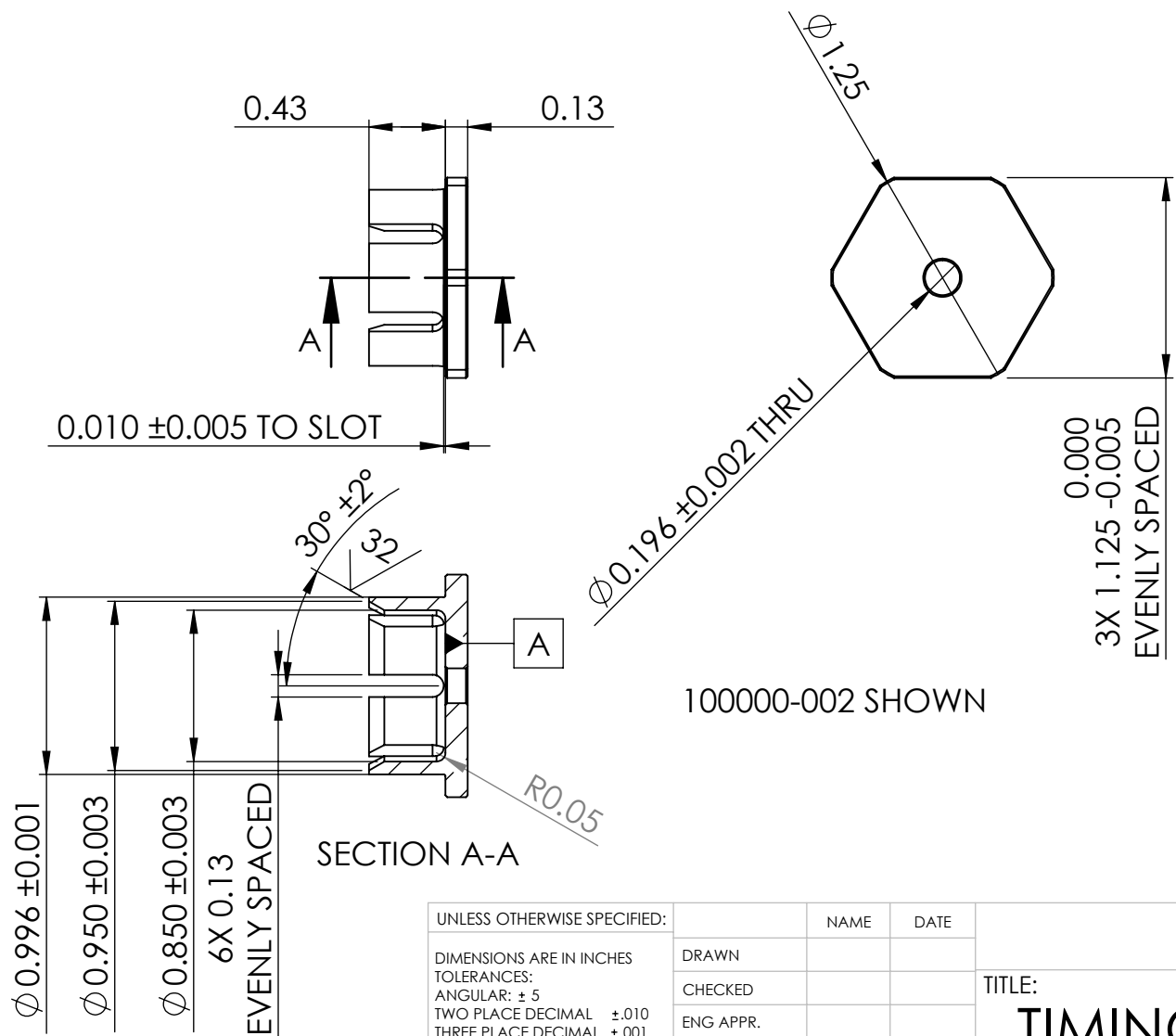

A

A

UNLESS OTHERWISE SPECIFIED:		NAME	DATE	TITLE: TIMING COVER PLUG			
DIMENSIONS ARE IN INCHES		DRAWN				SIZE	DWG. NO.
TOLERANCES:		CHECKED				A	100000
ANGULAR: ± 5		ENG APPR.				REV	A
TWO PLACE DECIMAL ±.010		MFG APPR.		SCALE: 1:1 WEIGHT:			
THREE PLACE DECIMAL ±.001		Q.A.		SHEET 2 OF 3			
INTERPRET GEOMETRIC TOLERANCING PER: Y14.5-2018		COMMENTS:					
MATERIAL							
FINISH							
63 RMS MAX							
DO NOT SCALE DRAWING							

2

1

2

1

B

B

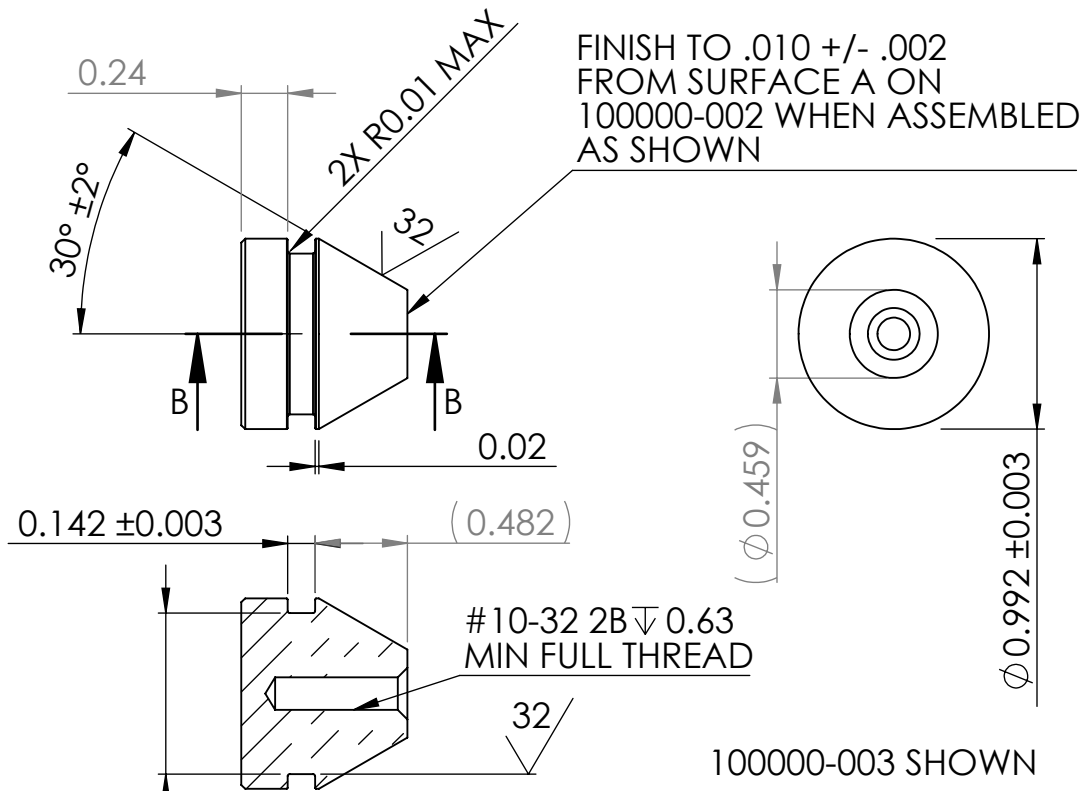

100000-003 SHOWN

SECTION B-B

A

A

UNLESS OTHERWISE SPECIFIED:

DIMENSIONS ARE IN INCHES
 TOLERANCES:
 ANGULAR: ± 5
 TWO PLACE DECIMAL ±.010
 THREE PLACE DECIMAL ±.001

INTERPRET GEOMETRIC
 TOLERANCING PER: Y14.5-2018
 MATERIAL

FINISH
 63 RMS MAX

DO NOT SCALE DRAWING

	NAME	DATE
DRAWN		
CHECKED		
ENG APPR.		
MFG APPR.		
Q.A.		
COMMENTS:		

TITLE:

TIMING COVER PLUG

SIZE	DWG. NO.	REV
A	100000	A

SCALE: 1:1	WEIGHT:	SHEET 3 OF 3

2

1