

Contents

Overview	2 – 5
System Description	6 – 7
System Operation	8 – 15
Components	16 – 23
Diagnostic Trouble Codes (Blink Codes)	24

The DTC Summary for this section follows at the end of the section.

Overview

The Teves MK II brake system combines normal system operation, hydraulic power boost and anti-lock braking. The system uses an independent electrically-driven motor / pump unit to provide both boost pressure and brake application pressure. A common operating fluid, DOT 4 BRAKE FLUID, is used for both power boost and brake application.

In this system, three hydraulic circuits are used — one to each front wheel and one to the rear wheels. Depending on the mode of operation, the circuits operate differently:

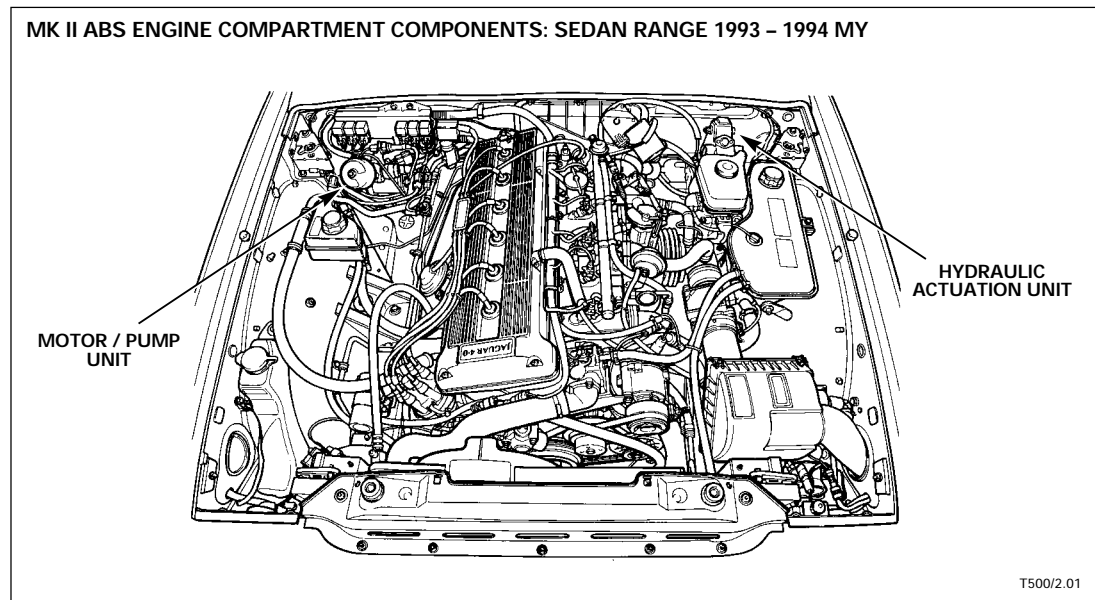

Normal Operation

The two front hydraulic circuits operate conventionally via the master cylinder, assisted by the hydraulic booster. The rear hydraulic circuit is operated continuously by the controlled pressure in the booster via the pressure reducing valve. Simply stated, during normal operation, the front hydraulic circuits are "static" and the rear circuit "dynamic."

Anti-lock Operation

When anti-lock control is required, the front hydraulic circuits also become "dynamic" as boost pressure replaces master cylinder pressure via the main valve.

The four wheel speed sensors input to the ABS control module (ABS CM), which processes the information and modulates the three sets of solenoid valves in the valve block to control the pressure in the three circuits and prevent wheel lock. Because both rear wheels share a common circuit, a tendency for one wheel to lock will result in control of both wheels according to the need of the "locking" wheel.

The state of the anti-lock braking system is continuously monitored by the ABS CM. If a system fault is detected, the CM flags a diagnostic trouble code (DTC) corresponding to the fault, activates the ANTI LOCK MIL, stores the DTC in its nonvolatile memory and signals the instrument pack vehicle condition monitor (VCM). For most faults the CM will also switch the system OFF until the fault is corrected.

Full boosted braking to all wheels is maintained if the control module switches off the ABS system. If a failure of the hydraulic boost portion of the system occurs, the brake system will function on the front wheels only, without boost pressure.

Fault Diagnostics

In addition to JDS and PDU diagnostics accessed through the dedicated ABS diagnostic connector, located near the CM, the TEVES MK II anti-lock braking system incorporates a facility that allows the numeric DTCs to be displayed as coded blinks on the ABS MIL.

Refer to page 24 for instructions for activating the "blink code" display.

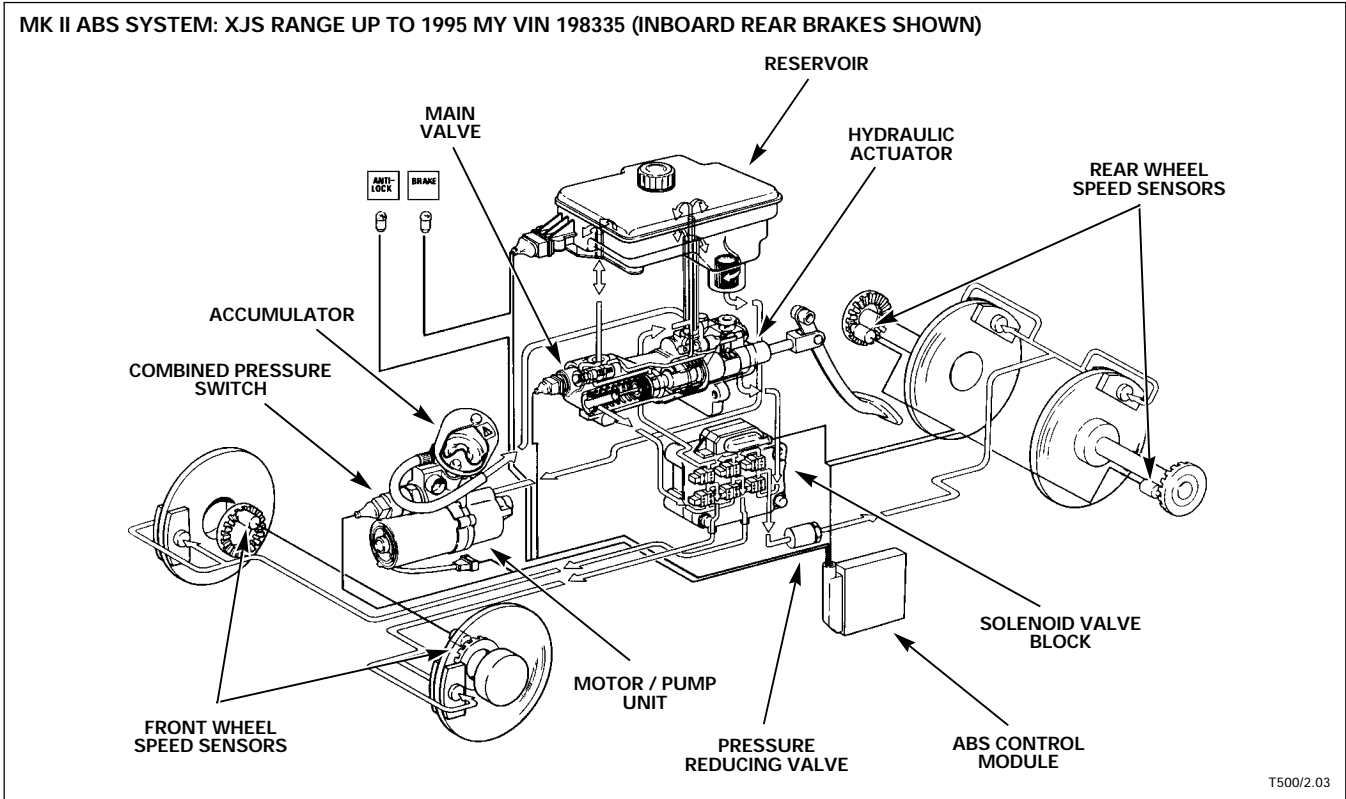
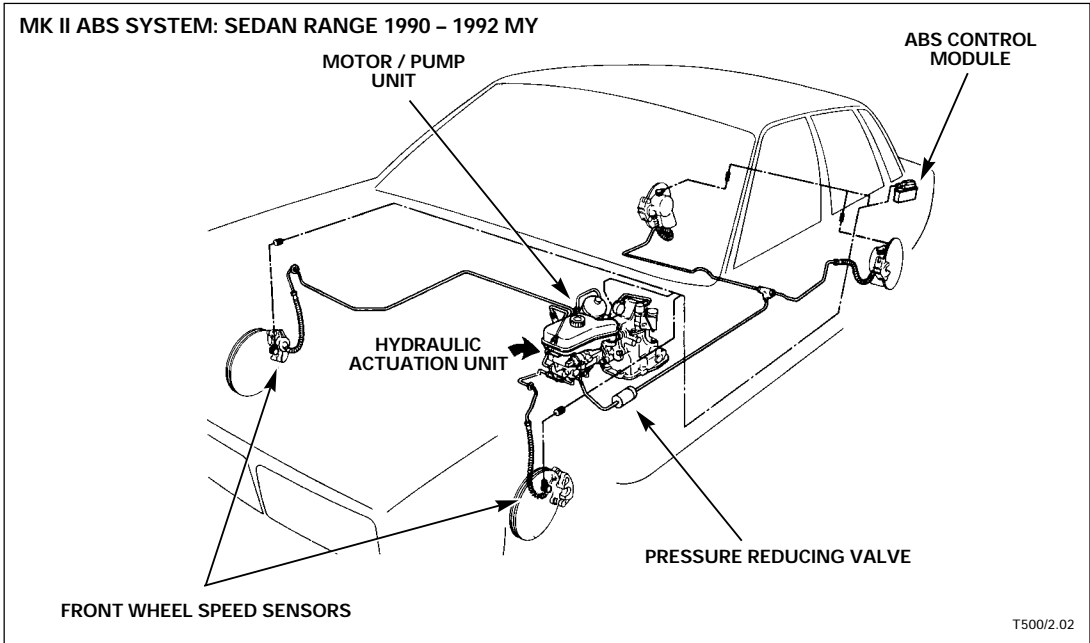

Overview (continued)

Sedan Range: 1990 – 1992 MY

In the Sedan Range from model years 1990 – 92, the motor / pump unit, reservoir and hydraulic actuation unit are integrated on the brake pedal and accelerator housing. The motor / pump unit contains the hydraulic pump, motor, accumulator and combined pressure switch. The hydraulic actuator incorporates many components including the solenoid valve block.

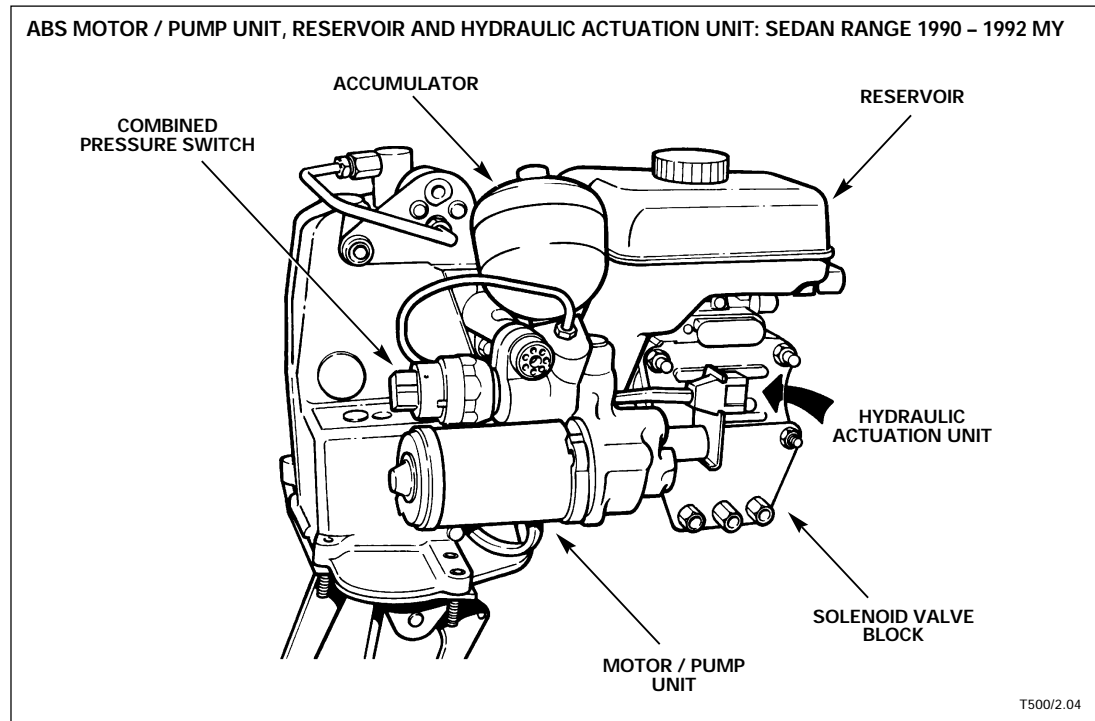

NOTES

Sedan Range: 1993 – 1994 and XJS Range: 1989 – 1995 MY

In all XJS Range models and 1993 – 94 Sedan Range models, the motor / pump unit is located separately on the right side of the firewall. The reservoir and the hydraulic actuation unit are integrated on the brake pedal and accelerator housing. The motor / pump unit contains the hydraulic pump, motor, accumulator and combined pressure switch. The hydraulic actuator incorporates many components including the solenoid valve block.

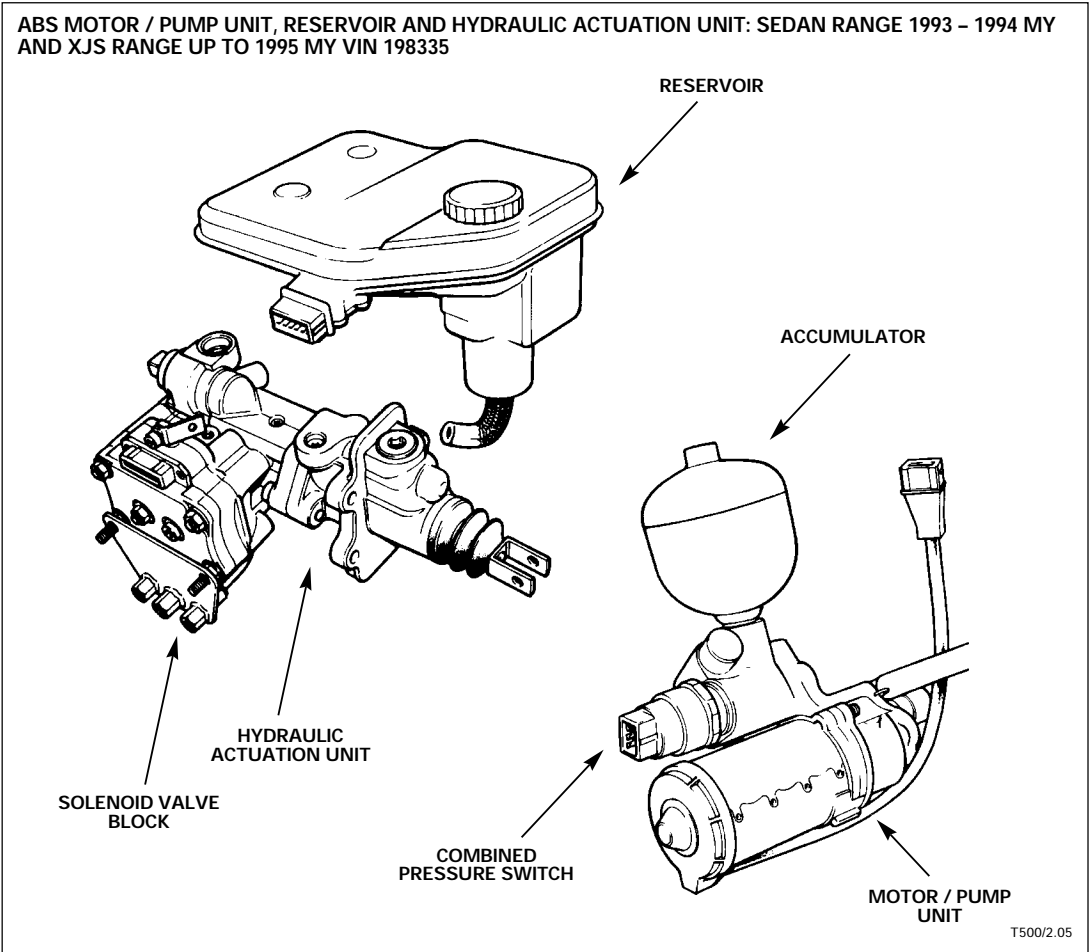

NOTES

System Description

Hydraulic Actuation Unit

The hydraulic actuation unit contains the reservoir and the components used for pressure application, boost application and anti-lock valving.

Actuating piston

The actuating piston transmits the motion from the brake pedal to the control valve and the boost piston.

Control valve

The control valve opens and closes the high pressure line from the accumulator to the actuator hydraulic booster.

Hydraulic booster

The boost piston is independent from the actuating piston and applies boost pressure on the master cylinder piston. Boost pressure is used to directly operate the rear brakes.

Master cylinder

The master cylinder operates the front brakes only.

Main valve

The solenoid-activated main valve is opened under anti-lock conditions to apply boost pressure directly to the master cylinder and the front brake circuits.

Central valve

The central valve opens under anti-lock conditions to allow boost pressure to be applied directly to the front brakes.

Positioning sleeve

The positioning sleeve is used during anti-lock operation to minimize brake pedal pulsation.

Solenoid valves

The six solenoid valves direct hydraulic pressure and hydraulic return in the three brake circuits during anti-lock conditions. During normal operation, the valves are at rest, allowing conventional application.

Motor / Pump Unit

The motor / pump unit supplies the system-operating hydraulic pressure.

Pump

The pump is driven by an electric motor and is switched on and off to maintain a range of operating pressure.

Accumulator

The accumulator stores the pump pressure and provides reserve for normal, anti-lock and pump failure operations. A check valve prevents pressure loss.

Pressure control valve

The pressure control valve limits the maximum system pressure to 210 bar (3046 psi).

Combined pressure switch

Two sets of contacts in the pressure-operated switch signal the ABS control module for activation of warnings and anti-lock shutdown. The other contacts switch the pump on and off. (The brake warning switch contacts close at 105 bar [1255 psi] turning on the warning light. The pump switches on at approximately 140 bar [2030 psi] and off at approximately 180 bar [2610 psi].)

Pressure Reducing Valve

Because the rear brakes operate directly off boost pressure, a pressure-limiting device is necessary. The pressure reducing valve is located in the rear brake circuit and limits the pressure applied to the rear brakes. (A differential of 6 bar [87 psi] is maintained between the front and rear circuits.)

TEVES MK II ABS SYSTEM DIAGRAM

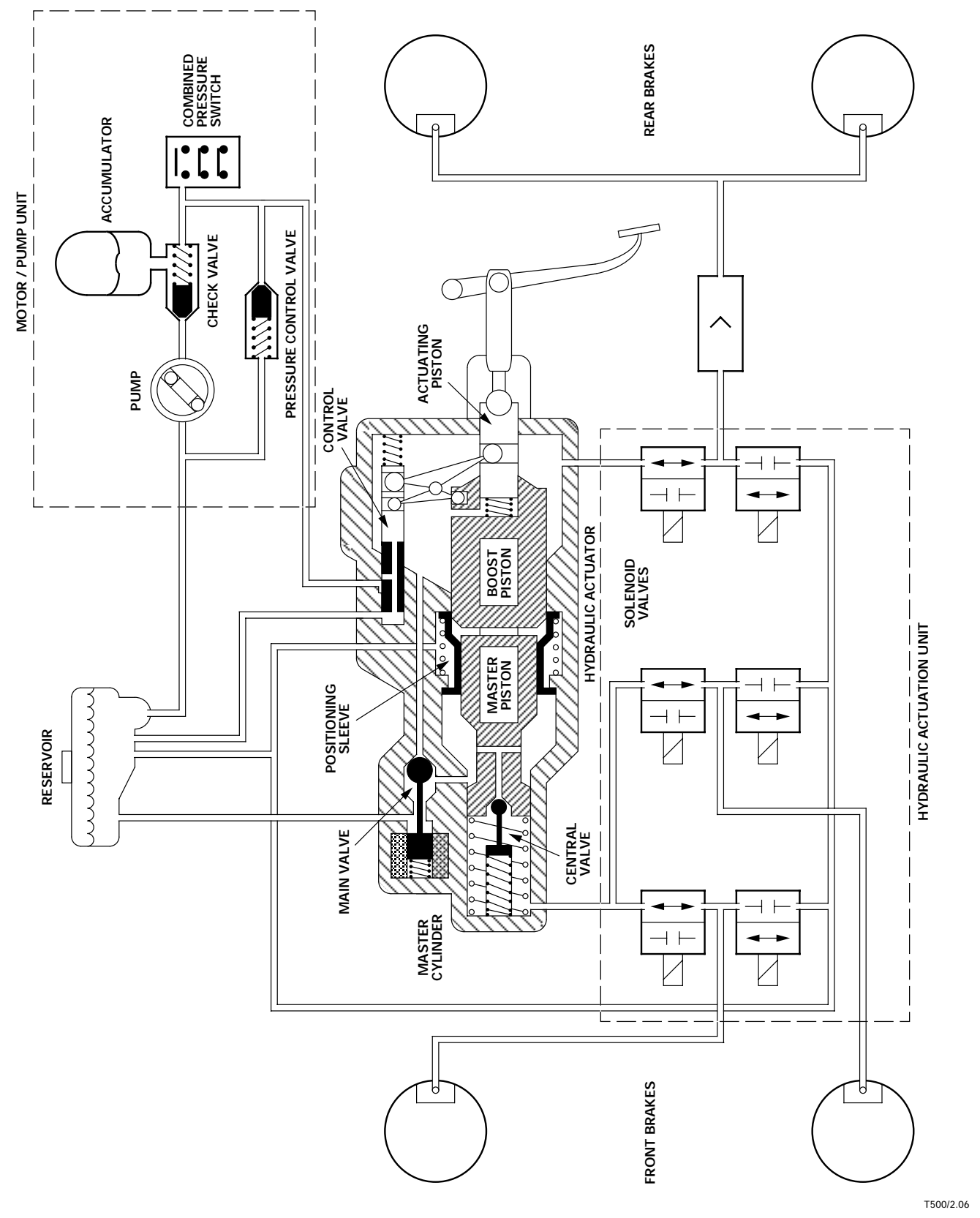

T500/2.06

System Operation

Brakes Not Applied

Control valve

The control valve is open to the reservoir and closed to accumulator pressure from the motor / pump unit.

Pump

The pump is switched on or off as determined by system pressure.

Accumulator

The accumulator stores boost pressure for use as soon as brakes are applied.

Boost piston

The boost piston is retracted.

Positioning sleeve

The positioning sleeve is at rest.

Master cylinder

The master cylinder is at rest.

Main valve

The main valve is switched off.

Equalized hydraulic pressure The hydraulic pressure is equalized throughout the system (except in the accumulator-to-control valve line).

NOTES

TEVES MK II ABS SYSTEM: BRAKES NOT APPLIED

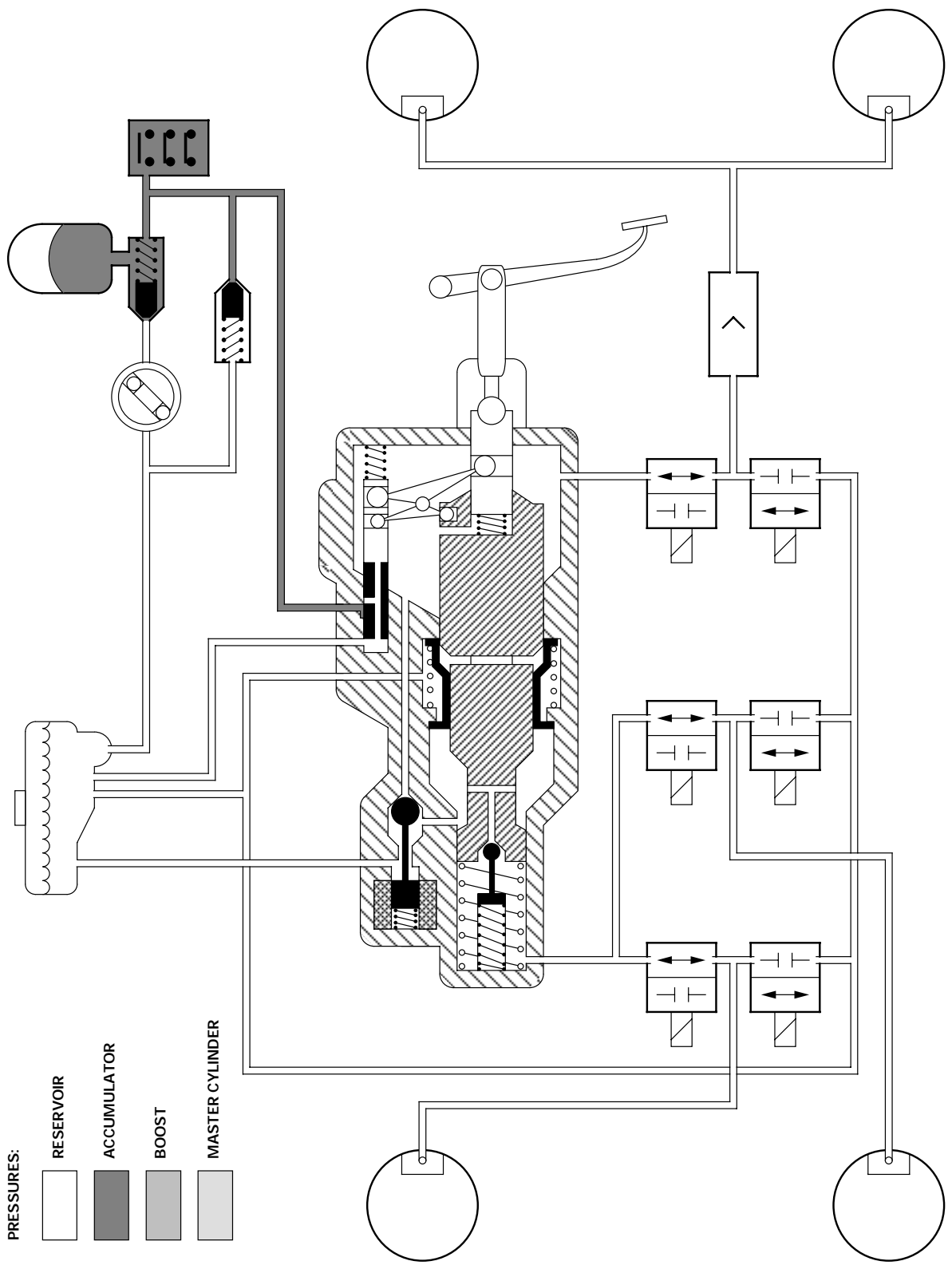

T500/2.07

System Operation

Brakes Applied: Normal Operation

Control Valve

As the driver applies force to the brake pedal, the actuating piston moves forward. The lever mechanism moves the control valve forward, opening the port from the accumulator and closing the return port to the reservoir. Boost pressure is applied to the boost piston and the rear brakes.

Boost Piston

The boost piston increases the pedal force acting on the master cylinder piston.

Main Valve

The main valve remains at rest, connecting the master cylinder to the reservoir.

Central Valve

As the master cylinder piston moves forward, the central valve closes and pressure is built up in the front brake circuits.

Positioning Sleeve

The positioning sleeve moves forward with the boost piston. The displaced fluid returns to the reservoir through the main valve, which is at rest.

Pressure Reducing Valve

Boost pressure is applied to the rear brakes through the pressure reducing valve.

Solenoid Valves

All solenoid valves are at rest, allowing pressure application and preventing return to the reservoir.

Boost Pressure Control

As the boost pressure increases, it acts between the boost piston and the actuating piston, moving the actuating piston back, which moves the control valve to close the port from the accumulator. The control valve closes the accumulator pressure port when the pedal force and boost force acting on the actuating piston equalize. The return port to the reservoir remains closed. The resulting pressure in the booster is proportional to the pedal force:
low pedal force = low pressure, high pedal force = high pressure.

“Dynamic”, “Static” During normal operation, boost pressure is applied directly to the rear brake circuit, thus the description “dynamic”. The front brake master cylinder is supplied with reservoir gravity pressure only, thus the description “static.”

NOTES

TEVES MK II ABS SYSTEM: BRAKES APPLIED - NORMAL OPERATION

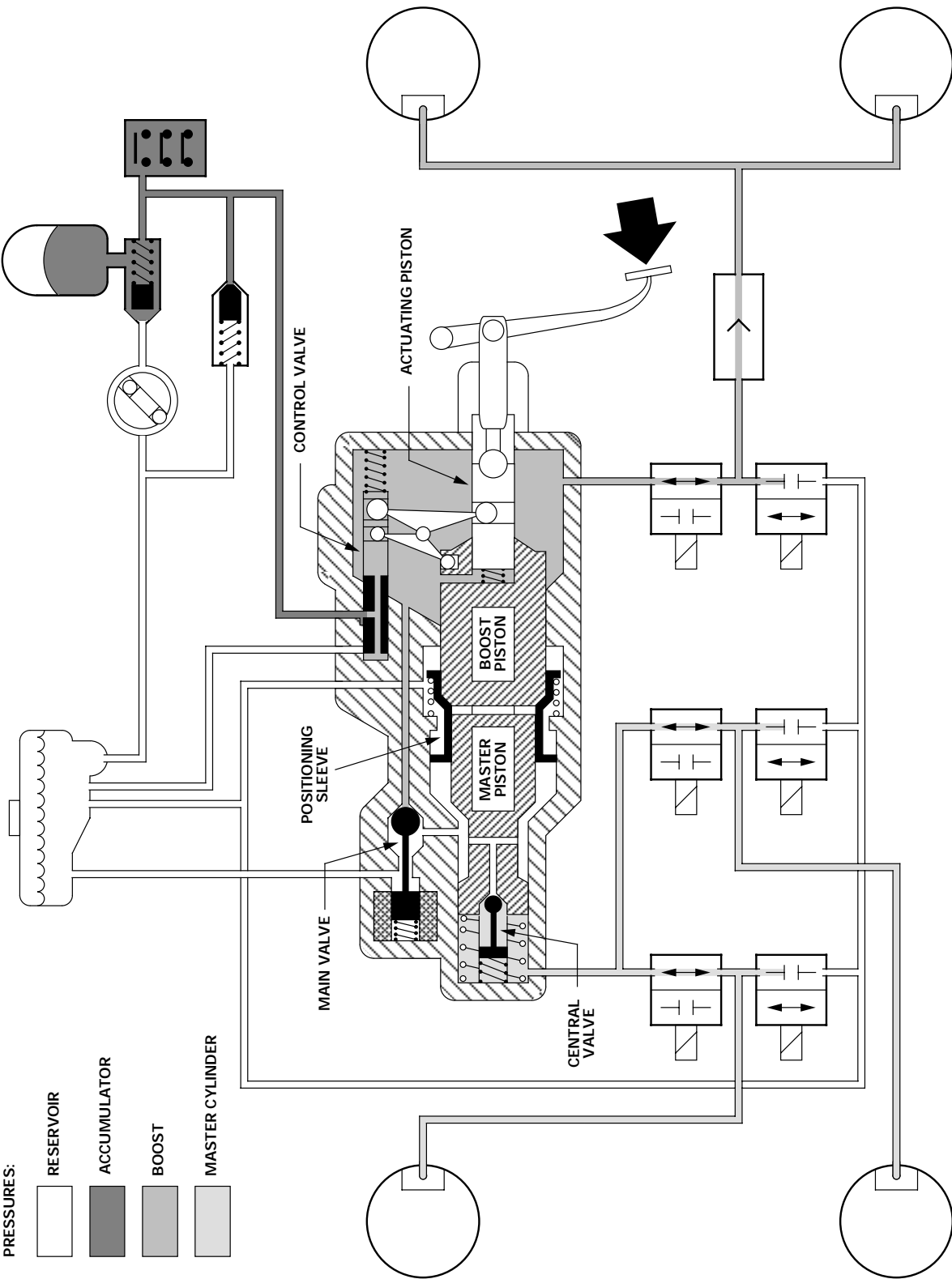

T500/2.08

System Operation

Brakes Applied: Anti-Lock Operation

Main Valve

When the ABS control module senses the need for ABS control, it activates the main switch, which moves the main valve, closing the reservoir feed line and applying boost pressure to the master cylinder circuit.

Central Valve

The central valve is held open by the pressure, allowing boost pressure to be applied directly to the front brake circuits.

Positioning Sleeve

The positioning sleeve is gradually moved to its rest position by the boost pressure. This action pushes back the boost piston, the actuating piston and the brake pedal, minimizing ABS pulsation transmitted to the brake pedal.

Solenoid Valves

The solenoid valves are modulated by the ABS control module, as necessary, to prevent wheel lock.

“Dynamic” During ABS operation, both the front and rear brake circuits are “dynamic”, as the front brakes are also operated directly by boost pressure.

NOTES

TEVES MK II ABS SYSTEM: BRAKES APPLIED - ANTI-LOCK OPERATION

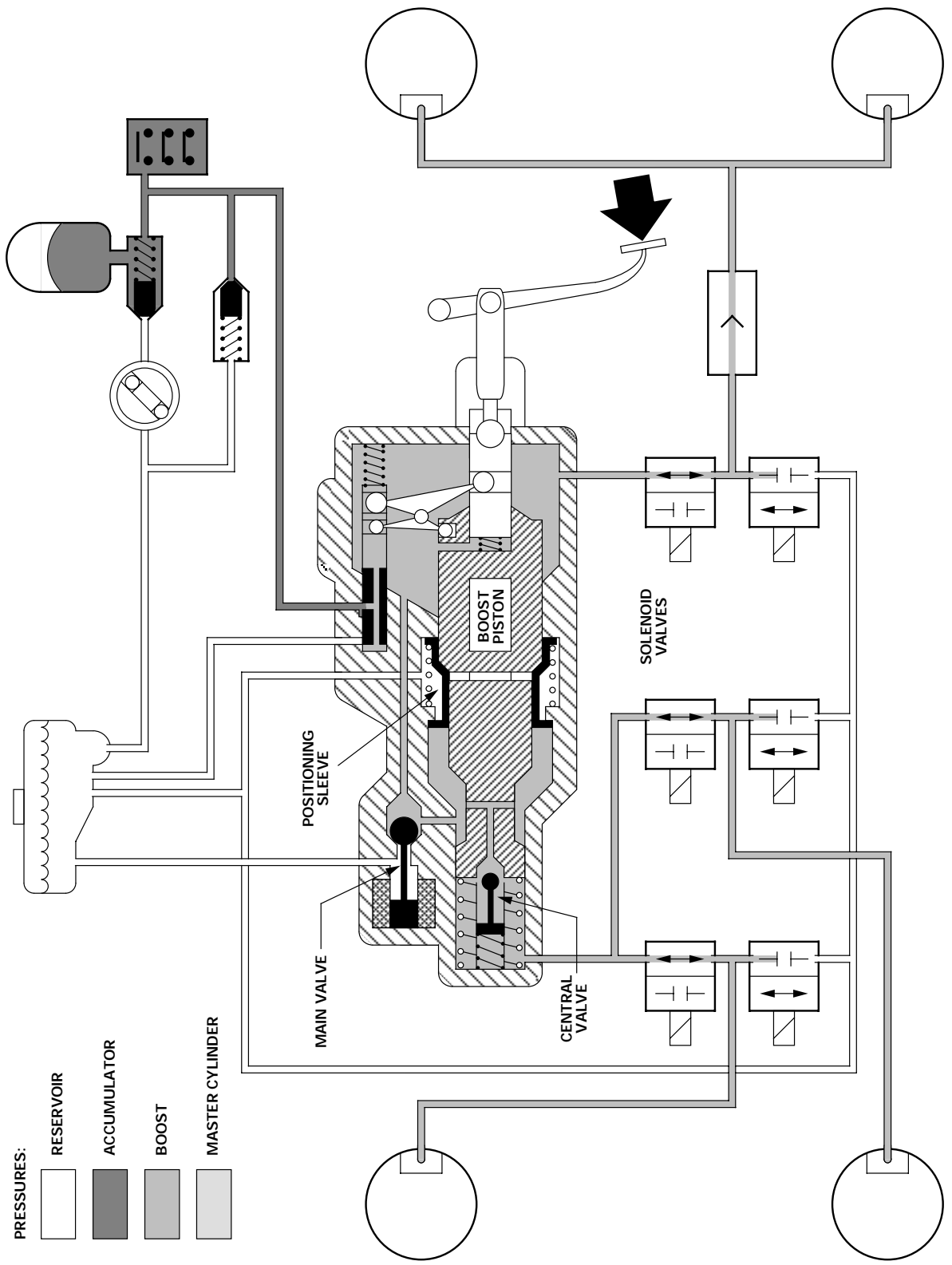

T500/2.09

System Operation (continued)

Solenoid Valve Operation

A pair of solenoid valves for one control circuit is shown. During ABS operation, the ABS control module modulates the valves in three phases as necessary to prevent wheel lock. The three phases are repeated up to six times per second until wheel lock is eliminated.

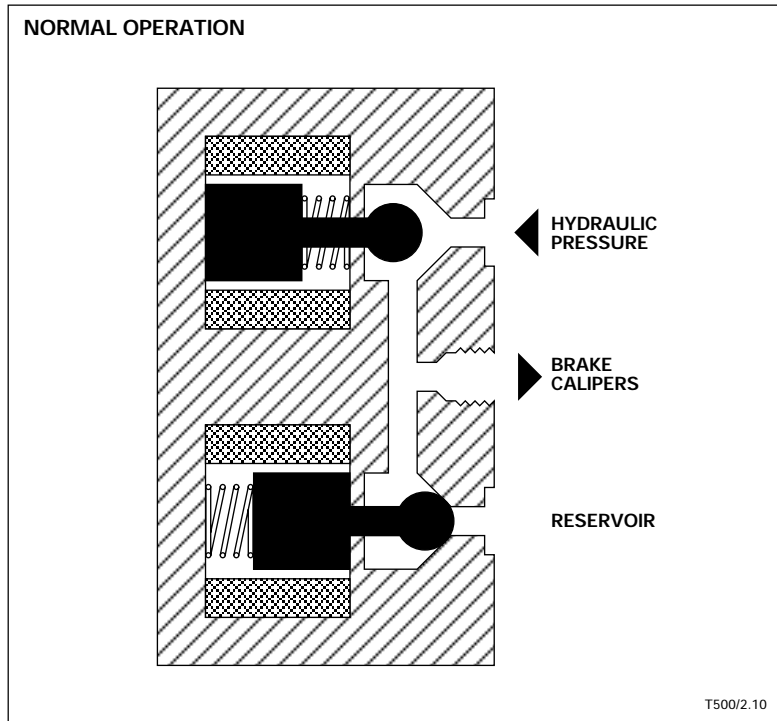

Normal operation

During normal braking operation, the solenoid valves are not controlled by the ABS control module and no current is applied. The inlet valve is open and the outlet valve is closed, porting hydraulic pressure to the brake caliper circuits.

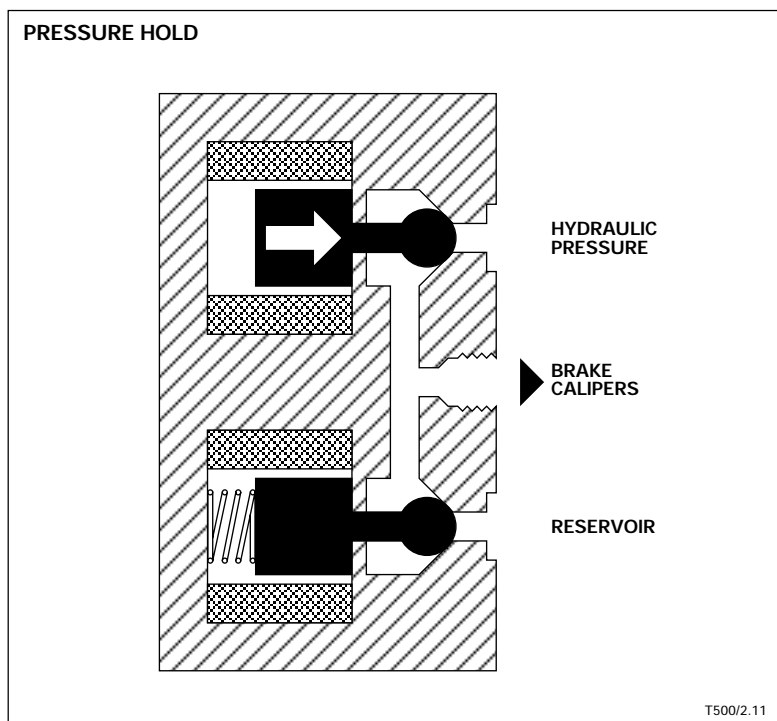

Phase one: Pressure hold

To maintain brake pressure, the ABS control module activates the inlet valve, which closes and prevents the application of additional hydraulic pressure. The outlet valve remains closed, preventing return to the reservoir.

NOTES

Phase two: Pressure reduce

If a wheel still has a tendency to lock with the pressure maintained, the ABS control module activates both valves, which prevents the application of hydraulic pressure and allows return to the reservoir, decreasing the pressure in the brake circuit.

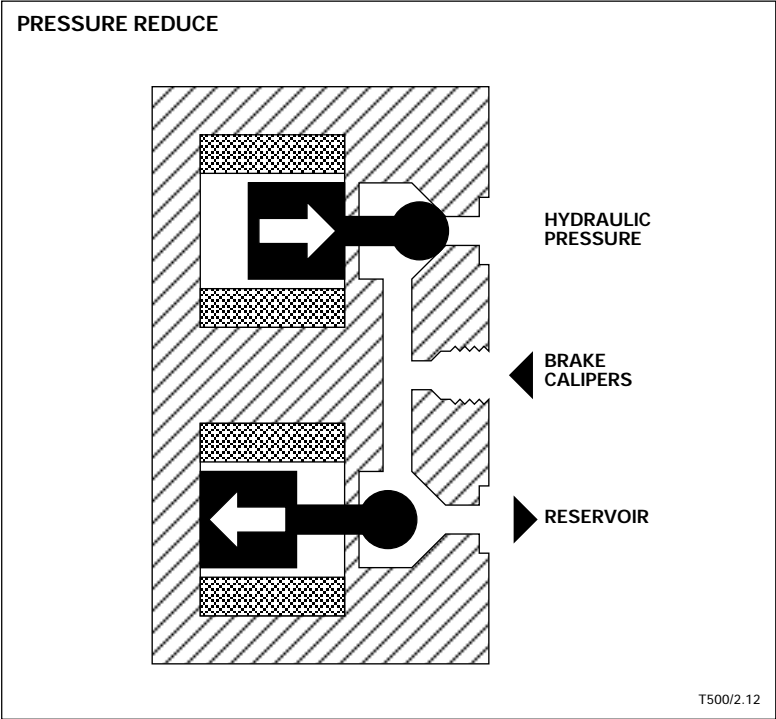

Phase three: Pressure increase

As the wheel accelerates, the ABS control module deactivates both valves, allowing hydraulic pressure to be applied to the brakes.

NOTES

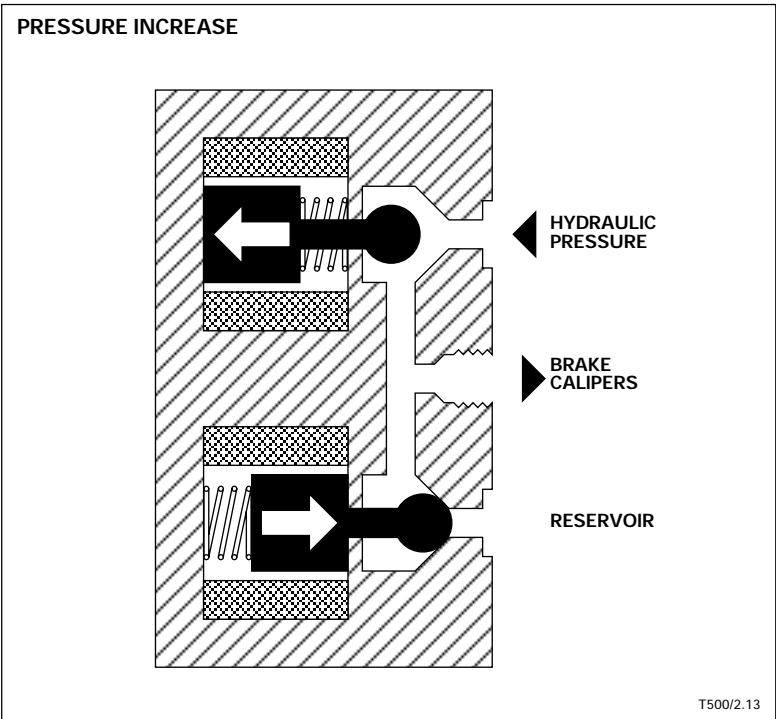

Components

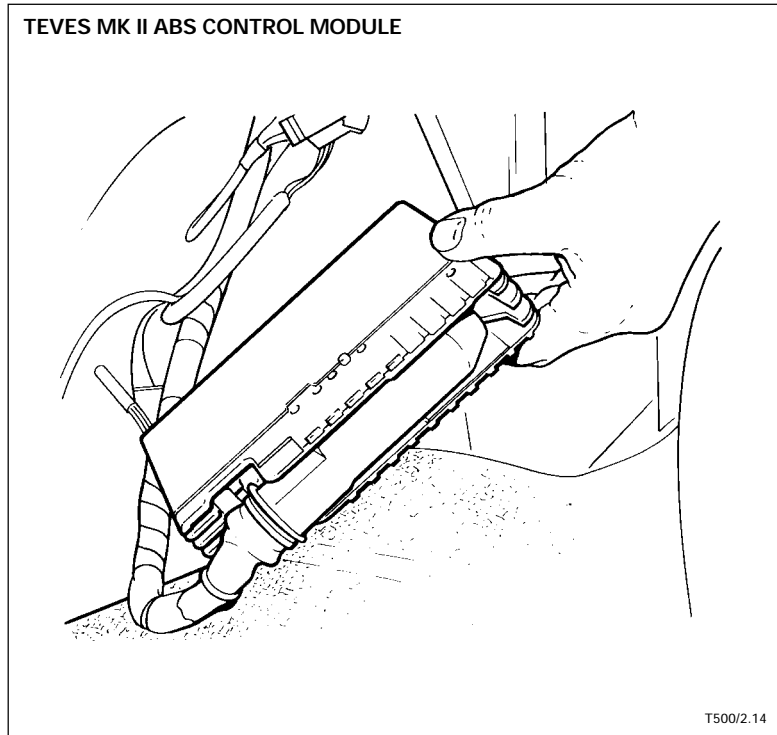

ABS Control Module

The ABS control module (ABS CM) processes information from the wheel speed sensors and the various switches for system operation, control and warnings. The wheel speed input signals are converted into values that correspond to relative individual wheel speed. These values are used to control the solenoid valves during ABS operation.

A vehicle speed is output to the instrument pack for distribution to other vehicle systems. The speed signal is provided from the ABS CM on 1993 and 94 Model Year Sedan Range vehicles. The left rear wheel speed sensor input is used as the wheel speed source.

ABS CM diagnostic monitoring

Each time the ignition is switched ON, the ABS CM conducts a self-test to determine system condition. The length of the test is dependent on the time required for charging of the accumulator. The instrument pack ABS MIL is illuminated during this test. If a fault is detected by the CM, the ABS MIL remains activated, the ABS system is switched off and a DTC is stored in memory.

During routine driving, the CM continuously monitors the system input and output signals. If a failure is detected, the ABS MIL is activated. If an ABS fault is detected, ABS is canceled; however, normal boosted braking will be maintained.

Refer to the DTC Summary following this section of the book.

NOTES

Hydraulic Brake Booster

The hydraulic booster boosts brake pedal force using hydraulic force supplied from the system pump. The pressure in the booster is proportional to the pedal force. Brake hydraulic pressure to the rear wheel brakes is applied through the control valve. Because the rear brakes are always operated dynamically, the hydraulic pressure to the rear brakes will never exceed 195 bar (maximum system pressure).

Hydraulic brake booster diagnostic monitoring

Hydraulic brake booster pressure is monitored by the CM via the combined pressure switch.

Refer to the DTC Summary following this section of the book.

NOTES

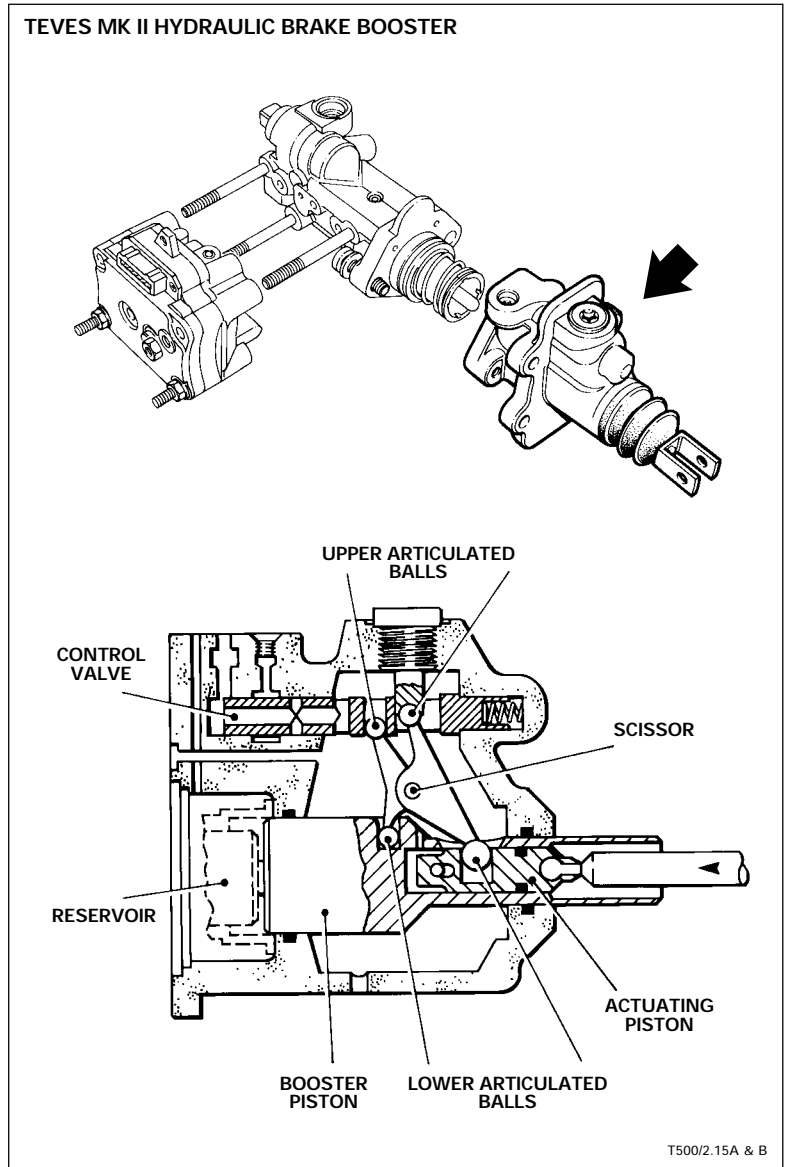

Components (continued)

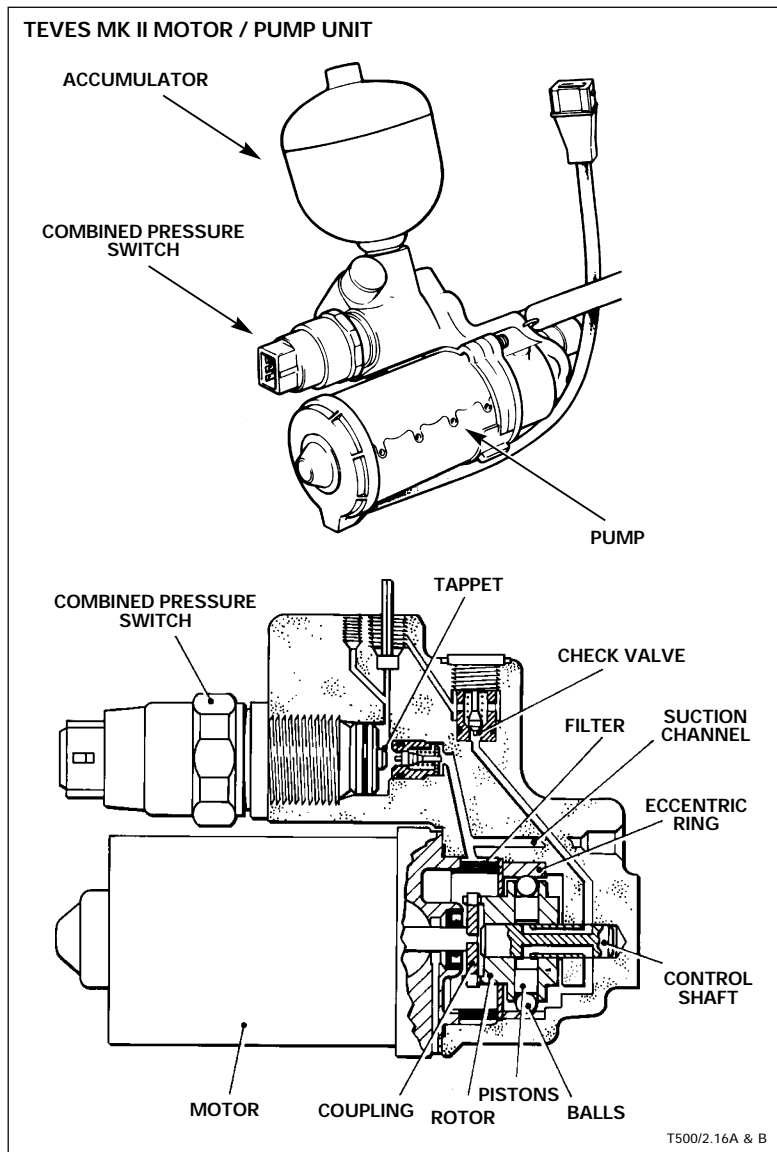

Motor / Pump Unit

The pump supplies hydraulic pressure for system operation. When hydraulic pressure in the accumulator falls to the low switching point, 128.5 – 149 bar (1863 – 2161 psi), the pump is switched ON by the combined pressure switch and pressurizes the system until the accumulator pressure reaches the high switching point, 171 – 195 bar (2480 – 2828 psi).

Hydraulic accumulator

Adequate system hydraulic pressure is maintained by the hydraulic accumulator. The accumulator is a pressure vessel with two chambers separated by a membrane. The upper chamber is charged with nitrogen gas at an initial pressure of 84 bar (1218 psi). The lower chamber fills with pressurized hydraulic fluid and is made available for system operation. Accumulator pressure is maintained by a check valve located in the motor / pump unit.

NOTES

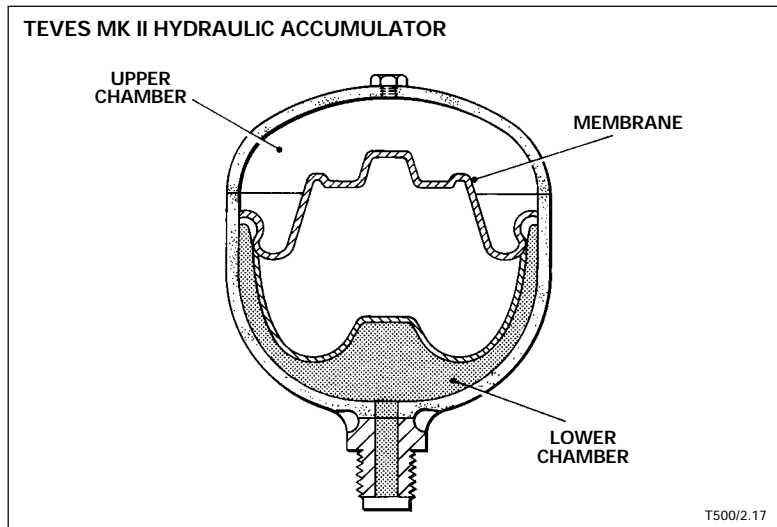

Combined pressure switch

The combined pressure switch contains three pressure-operated switches. The two "normally open" switches close when normal operating pressure is reached, switching off the pump and the BRAKE warning. The third "normally closed" switch opens if the system pressure falls too low and signals the ABS control module, which lights the ABS MIL. XJS 1989 MY systems use a combined pressure switch with two "normally closed" switches and one "normally open" switch.

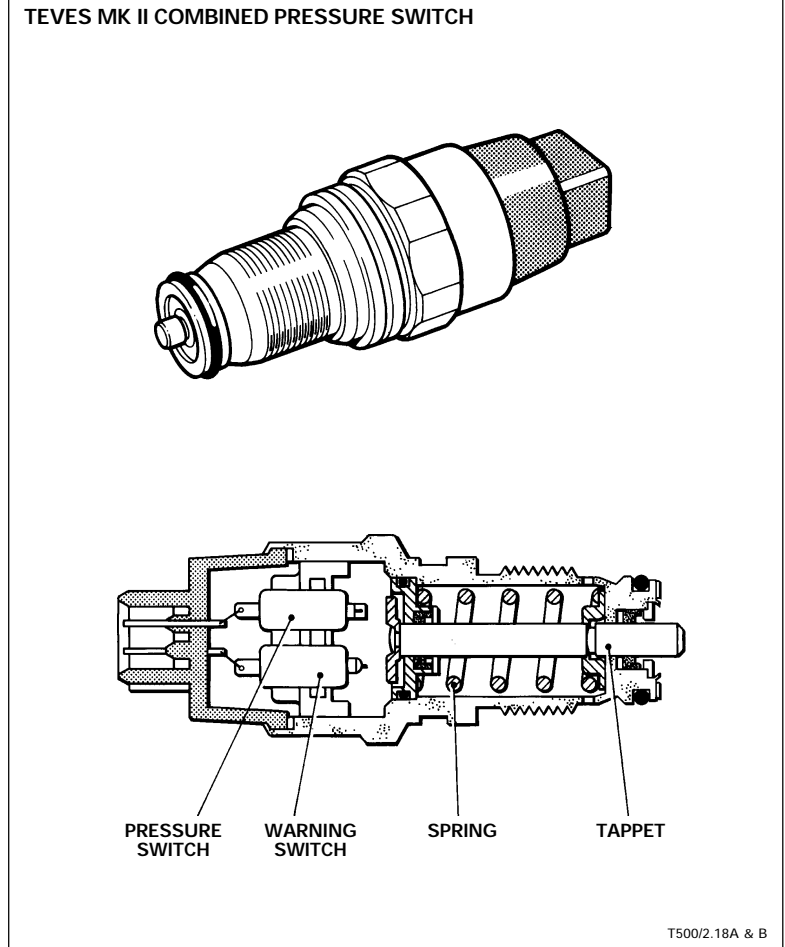

Motor / pump unit, hydraulic accumulator and combined pressure switch diagnostic monitoring

A failure in the motor / pump unit, hydraulic accumulator or combined pressure switch will be detected by CM monitoring of hydraulic pressure via the combined pressure switch.

Refer to the DTC Summary following this section of the book.

NOTES

Components (continued)

TEVES MK II VALVE BLOCK

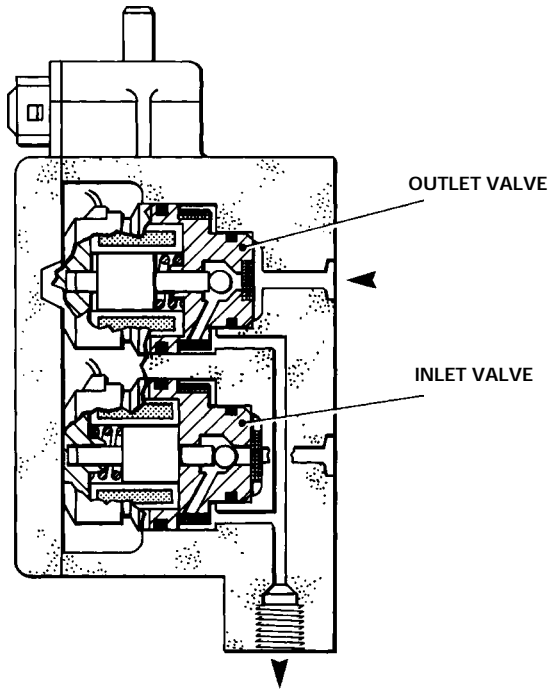
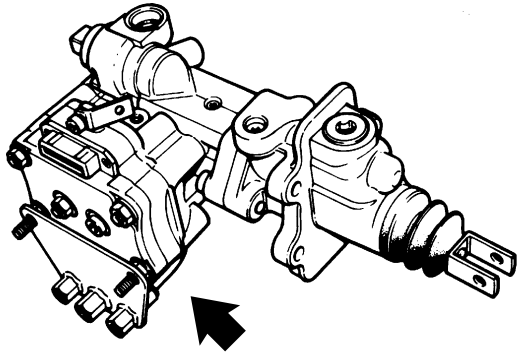

T500/2.19A & B

Valve Block

The valve block contains three pairs of electronically controlled solenoid valves. One pair of solenoid valves (one inlet and one outlet valve) is used for each brake circuit. If a wheel approaches lockup during ABS operation, the CM controls the brake apply pressure in the wheel's hydraulic circuit by modulating the solenoid valve operation.

Valve block diagnostic monitoring

The CM continuously monitors ABS system operation and the state of the components. If the CM detects a solenoid valve electrical or hydraulic failure, the ABS system is switched off, the ABS MIL is activated and a DTC is stored in memory.

Refer to the DTC Summary following this section of the book.

NOTES

Master Cylinder

The master cylinder acts on the front brakes only (static hydraulic circuit). The hydraulic pressure in the master cylinder is generated by the force applied from the booster piston. The main valve is incorporated into the master cylinder.

Main valve

The solenoid operated main valve is activated by the ABS control module during ABS control to supply the front wheel brakes and the positioning sleeve with system hydraulic pressure. The hydraulic force acting on the positioning sleeve moves the sleeve to push back the brake pedal.

Master cylinder and main valve diagnostic monitoring

The main valve is continuously monitored by the ABS CM. If the CM detects a main valve or hydraulic pressure failure, the ABS system is switched off, the ABS MIL is activated and a DTC indicating the failure mode is stored.

Refer to the DTC Summary following this section of the book.

NOTES

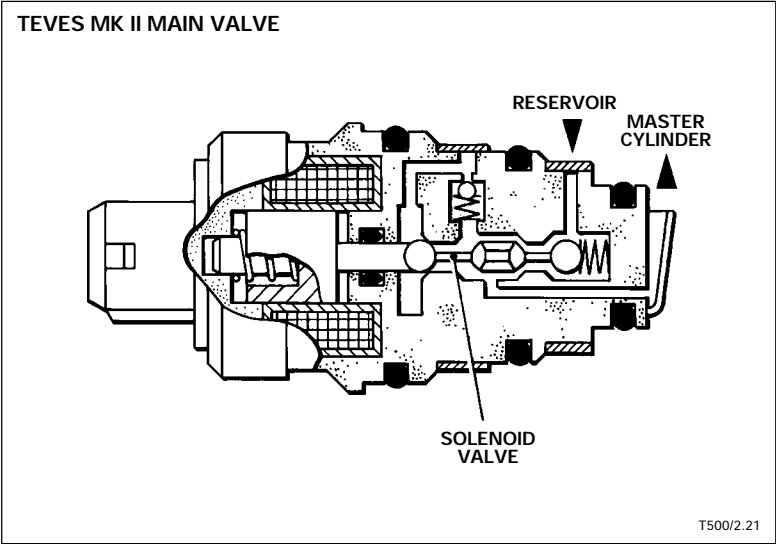
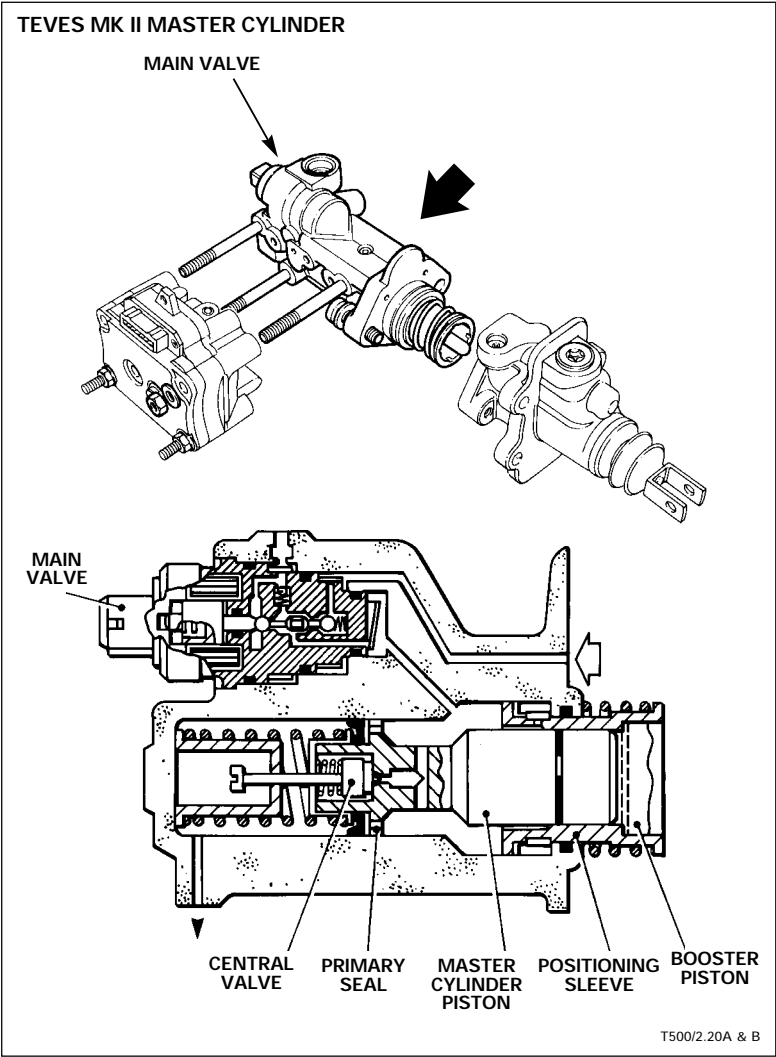

Components (continued)

Reservoir

XJS Range

The reservoir contains three fluid-level operated reed switches. Two "normally open" switches light the BRAKE FAILURE warning if the level drops too low. The third, "normally closed" switch signals the ABS CM if the level drops below the minimum level required for full ABS operation. In this case, the ABS CM switches off the front wheel ABS and activates the ABS MIL.

Sedan Range

The reservoir contains two fluid-level operated reed switches. The "normally open" switch activates the VCM (vehicle condition monitor) BRAKE warning if the level drops too low. The "normally closed" switch signals the ABS CM if the level drops below the minimum level required for full ABS operation. In this case, the ABS CM switches off the front wheel ABS and activates the ABS MIL.

Diagnostic Connector

A diagnostic connector, located near the ABS control module, is provided for conducting system testing using JDS or PDU.

NOTES

Wheel Speed Sensors

Each wheel speed sensor is made up of a magnetic sensor and a rotating 48-tooth reluctor. When the reluctor turns, it produces electrical signals that are fed to the ABS CM as individual wheel speed information.

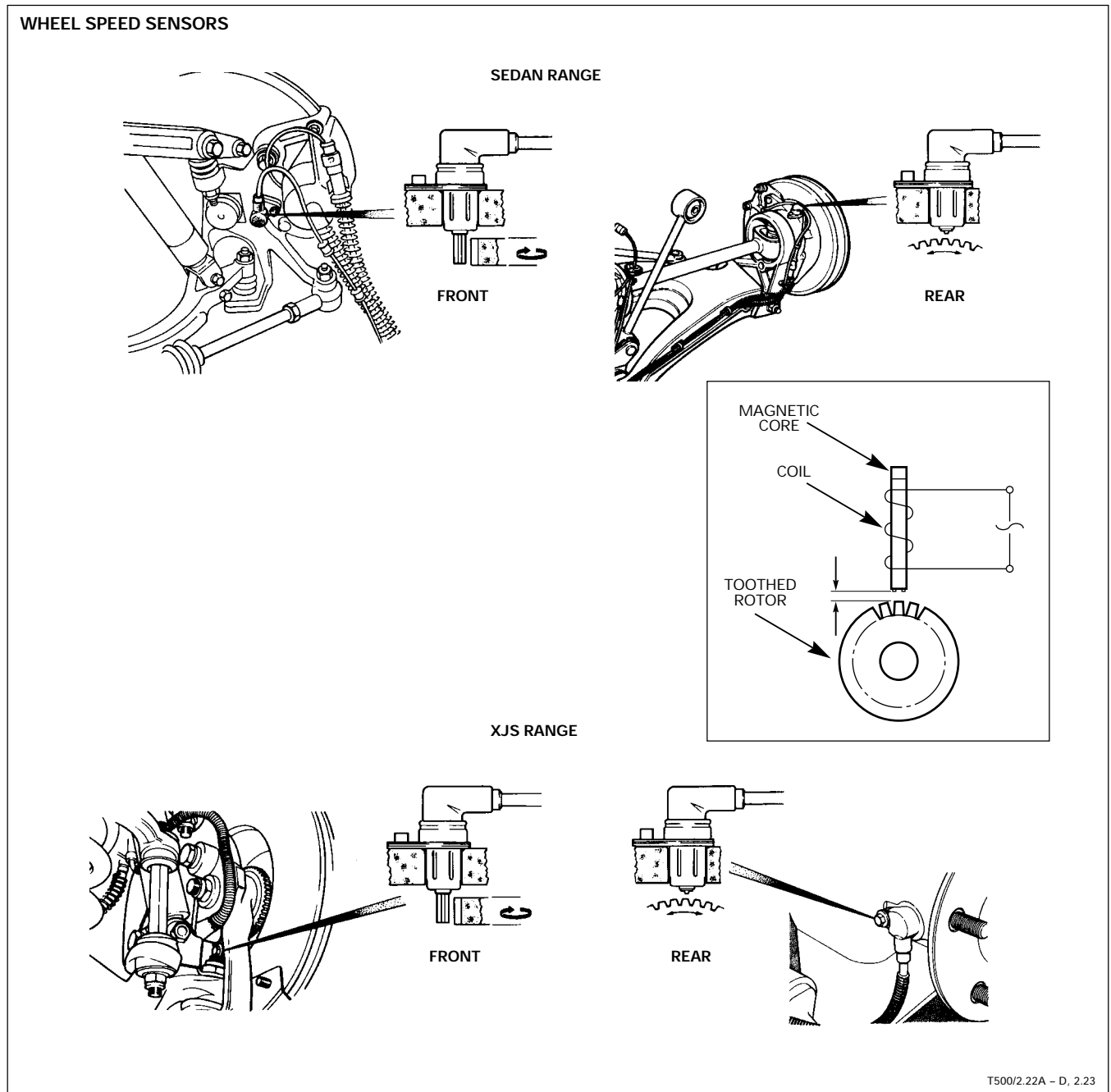

Wheel speed sensor diagnostic monitoring

The wheel speed sensors are continuously monitored by the CM. If the CM detects a sensor failure, the ABS system is switched off, the ABS MIL is activated and a DTC indicating the sensor and failure mode is stored.

Refer to the DTC Summary following this section of the book.

Diagnostic Trouble Codes (Blink Codes)

The ABS CM continuously monitors the ABS system input and output signals. If a failure is detected, the CM activates the ABS MIL and either switches the ABS system off or inhibits its operation, depending on the failure. The CM also stores a two digit code (DTC) that indicates the type of failure. Refer to the DTC Summary following this section of the book.

DTCs are displayed by coded flashes ('blink codes') of the ABS MIL.

TO ACTIVATE 'BLINK CODES' (DTC display):

- Switch the ignition OFF
- At the ABS diagnostic connector located in wheel arch near the ABS CM, jump the N/K (brown / pink) wire pin to the B (black) wire pin with a short JDS adapter.
- Observe the ABS MIL and switch the ignition ON. The 'BLINK CODE' sequence will begin in six seconds.
- Count the flashes (MIL 'BLINKS'). Each digit of the DTC is separated by a two second pause. Individual DTCs are separated by a six second pause.

EXAMPLE: Stored DTCs 21 and 31 display as follows:

*IGNITION ON ... (6 second pause) ...
2 BLINKS ... (2 second pause) ... 1 BLINK ... (6 second pause) ...
3 BLINKS ... (2 second pause) ... 1 BLINK ... (6 second pause) ...
SEQUENCE REPEATS...*

NOTE: The CM will only display one DTC at a time for each group.

FOR EXAMPLE: If two '20' DTCs (DTCs 21 and 24) and one '30' DTC (DTC 31) are stored, DTCs 21 and 31 will display. After repairing the causes of DTCs 21 and 31, perform the memory erase procedure (CLEAR CODES) and repeat the 'BLINK CODE' activation procedure. This verifies the repair and displays any remaining DTCs.

TO CLEAR CODES:

- Drive the vehicle at a speed greater than 19 mph (30 km/h).
- Perform the 'BLINK CODE' procedure to verify the repairs and check that no other DTCs are stored.

NOTES

DTC (Blink Code) Summary

Teves Mark II ABS System:

Sedan Range through 1994 MY; XJS Range up to 1995 MY VIN 198334

DTCs are stored in the ABS control module nonvolatile memory.

TO ACTIVATE 'BLINK CODES' (DTC display):

- Switch the ignition OFF
- At the ABS diagnostic connector located in wheel arch near the ABS CM, jump the N/K (brown / pink) wire pin to the B (black) wire pin with a short JDS adapter.
- Observe the ABS MIL and switch the ignition ON.
- The 'BLINK CODE' sequence will begin in six seconds.
- Count the flashes (MIL 'BLINKS'). Each digit of the DTC is separated by a two-second pause. Individual DTCs are separated by a six second pause.

EXAMPLE: Stored DTCs 21 and 31 display as follows:

IGNITION ON ... (6 second pause) ...

2 BLINKS ... (2 second pause) ... 1 BLINK ... (6 second pause) ...

3 BLINKS ... (2 second pause) ... 1 BLINK ... (6 second pause) ...

SEQUENCE REPEATS...

NOTE: The CM will only display one DTC at a time for each group.

FOR EXAMPLE: If two '20' DTCs (DTCs 21 and 24) and one '30' DTC (DTC 31) are stored, DTCs 21 and 31 will display. After repairing the causes of DTCs 21 and 31, perform the memory erase procedure (CLEAR CODES) and repeat the 'BLINK CODE' activation procedure. This verifies the repair and displays any remaining DTCs.

TO CLEAR CODES:

- Drive the vehicle at a speed greater than 19 mph (30 km/h).
- Perform the 'BLINK CODE' procedure to verify the repairs and check that no other DTCs are stored.

DTC	FAULT DESCRIPTION	MONITORING CONDITIONS	ABS MIL	DEFAULT ACTION	POSSIBLE CAUSES
11	ABS CM self test failure	Drive vehicle above 19 mph (30 km/h).	YES	OFF	ABS harness incorrect connection CM failure
12	ABS CM failure	Drive vehicle above 19 mph (30 km/h).	YES	OFF	CM failure
21	Main valve failure	Drive vehicle above 19 mph (30 km/h).	YES	OFF	Main valve to CM circuit; open circuit, short circuit to ground or B+ voltage Main valve ground circuit; open circuit, high resistance or short circuit to B+ voltage Main valve failure CM failure
22	Inlet valve left front	Drive vehicle above 19 mph (30 km/h).	YES	OFF	Valve to CM circuit; open circuit, short circuit to ground or B+ voltage Valve failure CM failure
23	Outlet valve left front	Drive vehicle above 19 mph (30 km/h).	YES	OFF	Valve to CM circuit; open circuit, short circuit to ground or B+ voltage Valve failure CM failure
24	Inlet valve right front	Drive vehicle above 19 mph (30 km/h).	YES	OFF	Valve to CM circuit; open circuit, short circuit to ground or B+ voltage Valve failure CM failure
25	Outlet valve right front	Drive vehicle above 19 mph (30 km/h).	YES	OFF	Valve to CM circuit; open circuit, short circuit to ground or B+ voltage Valve failure CM failure
26	Inlet valve rear	Drive vehicle above 19 mph (30 km/h).	YES	OFF	Valve to CM circuit; open circuit, short circuit to ground or B+ voltage Valve failure CM failure
27	Outlet valve rear	Drive vehicle above 19 mph (30 km/h).	YES	OFF	Valve to CM circuit; open circuit, short circuit to ground or B+ voltage Valve failure CM failure
31	Wheel speed sensor left front trigger signal failure	Drive vehicle above 19 mph (30 km/h).	YES	OFF	Wheel speed sensor to CM circuit; open circuit or short circuit to ground Wheel speed sensor failure CM failure
32	Wheel speed sensor right front trigger signal failure	Drive vehicle above 19 mph (30 km/h).	YES	OFF	Wheel speed sensor to CM circuit; open circuit or short circuit to ground Wheel speed sensor failure CM failure
33	Wheel speed sensor right rear trigger signal failure	Drive vehicle above 19 mph (30 km/h).	YES	OFF	Wheel speed sensor to CM circuit; open circuit or short circuit to ground Wheel speed sensor failure CM failure
34	Wheel speed sensor left rear trigger signal failure	Drive vehicle above 19 mph (30 km/h).	YES	OFF	Wheel speed sensor to CM circuit; open circuit or short circuit to ground Wheel speed sensor failure CM failure

DTC	FAULT DESCRIPTION	MONITORING CONDITIONS	ABS MIL	DEFAULT ACTION	POSSIBLE CAUSES
35	Wheel speed sensor left front speed continuity signal failure	Drive vehicle above 25 mph (40 km/h).	YES	OFF	Wheel speed sensor circuit to CM; intermittent open circuit or short circuit to ground Incorrect wheel speed sensor to reluctor air gap Loose wheel bearings or damaged reluctor Wheel speed sensor intermittent failure Refer to DTC 75 CM failure
36	Wheel speed sensor right front speed continuity signal failure	Drive vehicle above 25 mph (40 km/h).	YES	OFF	Wheel speed sensor circuit to CM; intermittent open circuit or short circuit to ground Incorrect wheel speed sensor to reluctor air gap Loose wheel bearings or damaged reluctor Wheel speed sensor intermittent failure Refer to DTC 76 CM failure
37	Wheel speed sensor right rear speed continuity signal failure	Drive vehicle above 25 mph (40 km/h).	YES	OFF	Wheel speed sensor circuit to CM; intermittent open circuit or short circuit to ground Incorrect wheel speed sensor to reluctor air gap Loose wheel bearings or damaged reluctor Wheel speed sensor intermittent failure Refer to DTC 77 CM failure
38	Wheel speed sensor left rear speed continuity signal failure	Drive vehicle above 19 mph (30 km/h).	YES	OFF	Wheel speed sensor circuit to CM; intermittent open circuit or short circuit to ground Incorrect wheel speed sensor to reluctor air gap Loose wheel bearings or damaged reluctor Wheel speed sensor intermittent failure Refer to DTC 78 CM failure
41	Wheel speed sensor left front wheel speed comparison failure or no signal	Drive vehicle above 19 mph (30 km/h).	YES	OFF	Wheel speed sensor circuit to CM; open circuit or short circuit to ground Incorrect wheel speed sensor to reluctor air gap Wheel speed sensor failure CM failure
42	Wheel speed sensor right front wheel speed comparison failure or no signal	Drive vehicle above 19 mph (30 km/h).	YES	OFF	Wheel speed sensor circuit to CM; open circuit or short circuit to ground Incorrect wheel speed sensor to reluctor air gap Wheel speed sensor failure CM failure
43	Wheel speed sensor right rear wheel speed comparison failure or no signal	Drive vehicle above 19 mph (30 km/h).	YES	OFF	Wheel speed sensor circuit to CM; open circuit or short circuit to ground Incorrect wheel speed sensor to reluctor air gap Wheel speed sensor failure CM failure
44	Wheel speed sensor left rear wheel speed comparison failure or no signal	Drive vehicle above 19 mph (30 km/h).	YES	OFF	Wheel speed sensor circuit to CM; open circuit or short circuit to ground Incorrect wheel speed sensor to reluctor air gap Wheel speed sensor failure CM failure
51	Outlet valve left front hydraulic failure	Drive vehicle above 25 mph (40 km/h), activate ABS	YES	OFF	Outlet valve hydraulic failure Refer to DTC 71 CM failure
52	Outlet valve right front hydraulic failure	Drive vehicle above 25 mph (40 km/h), activate ABS	YES	OFF	Outlet valve hydraulic failure Refer to DTC 72 CM failure

DTC	FAULT DESCRIPTION	MONITORING CONDITIONS	ABS MIL	DEFAULT ACTION	POSSIBLE CAUSES
53 or 54	Outlet valve rear hydraulic failure	Drive vehicle above 25 mph (40 km/h), activate ABS	YES	OFF	Outlet valve hydraulic failure Refer to DTC 73 / 74 CM failure
55	Wheel speed sensor left front no signal long term	Drive vehicle above 19 mph (30 km/h).	YES	OFF	Loose wheel speed sensor Incorrect wheel speed sensor to reductor air gap CM failure
56	Wheel speed sensor right front no signal long term	Drive vehicle above 19 mph (30 km/h).	YES	OFF	Loose wheel speed sensor Incorrect wheel speed sensor to reductor air gap CM failure
57	Wheel speed sensor right rear no signal long term	Drive vehicle above 19 mph (30 km/h).	YES	OFF	Loose wheel speed sensor Incorrect wheel speed sensor to reductor air gap CM failure
58	Wheel speed sensor left rear no signal long term	Drive vehicle above 19 mph (30 km/h).	YES	OFF	Loose wheel speed sensor Incorrect wheel speed sensor to reductor air gap CM failure
61	Pressure switches signal incorrect	Drive vehicle above 19 mph (30 km/h).	YES	OFF	Pressure switches; short circuit to ground or B+ voltage Reservoir to pressure switch to CM circuits; short circuit to ground or B+ voltage Pressure switch failure Accumulator, pump or motor failure CM failure
71	Wheel speed sensor left front RFI signal interference	Drive vehicle below 25 mph (40 km/h), activate ABS.	* Intermittent	INHIBITED	Sensor to CM ground circuit (shielding); high resistance or open circuit CM ground circuit; open circuit or high resistance Refer to DTC 51 CM failure
72	Wheel speed sensor right front RFI signal interference	Drive vehicle below 25 mph (40 km/h), activate ABS.	* Intermittent	INHIBITED	Sensor to CM ground circuit (shielding); high resistance or open circuit CM ground circuit; open circuit or high resistance Refer to DTC 52 CM failure
73	Wheel speed sensor right rear RFI signal interference	Drive vehicle below 25 mph (40 km/h), activate ABS.	* Intermittent	INHIBITED	Sensor to CM ground circuit (shielding); high resistance or open circuit CM ground circuit; open circuit or high resistance Refer to DTC 53 CM failure
74	Wheel speed sensor left rear RFI signal interference	Drive vehicle below 25 mph (40 km/h), activate ABS.	* Intermittent	INHIBITED	Sensor to CM ground circuit (shielding); high resistance or open circuit CM ground circuit; open circuit or high resistance Refer to DTC 54 CM failure
75	Wheel speed sensor left front speed continuity signal failure	Drive vehicle below 25 mph (40 km/h).	* Intermittent	INHIBITED	Sensor to CM ground circuit (shielding); high resistance or open circuit CM ground circuit; open circuit or high resistance Axle vibration. Incorrect bearing clearance or sensor air gap Refer to DTC 35 CM failure

* Low Priority Fault. MIL may or may not activate depending on other fault parameters. DTCs will be stored in memory.

DTC	FAULT DESCRIPTION	MONITORING CONDITIONS	ABS MIL	DEFAULT ACTION	POSSIBLE CAUSES
76	Wheel speed sensor right front speed continuity signal failure	Drive vehicle below 25 mph (40 km/h).	* Intermittent	INHIBITED	Sensor to CM ground circuit (shielding); high resistance or open circuit CM ground circuit; open circuit or high resistance Axle vibration, incorrect bearing clearance or sensor air gap Refer to DTC 36 CM failure
77	Wheel speed sensor right rear speed continuity signal failure	Drive vehicle below 25 mph (40 km/h).	* Intermittent	INHIBITED	Sensor to CM ground circuit (shielding); high resistance or open circuit CM ground circuit; open circuit or high resistance Axle vibration, incorrect bearing clearance or sensor air gap Refer to DTC 37 CM failure
78	Wheel speed sensor left rear speed continuity signal failure	Drive vehicle below 25 mph (40 km/h).	* Intermittent	INHIBITED	Sensor to CM ground circuit (shielding); high resistance or open circuit CM ground circuit; open circuit or high resistance Axle vibration, incorrect bearing clearance or sensor air gap Refer to DTC 38 CM failure

* Low Priority Fault. MIL may or may not activate depending on other fault parameters. DTCs will be stored in memory

COMPONENTS

DESCRIPTION	LOCATION	ACCESS
ANTI-LOCK BRAKING ECU	TRUNK, LEFT SIDE	TRUNK TRIM PANEL, LEFT
BRAKE SWITCH	DRIVER FOOTWELL	DRIVER FOOTWELL
COMBINED PRESSURE SWITCH	LEFT FRONT BULKHEAD	ENGINE COMPARTMENT
DIAGNOSTIC SOCKET	LEFT FRONT CORNER OF TRUNK	TRUNK
DIODE—LSD5	FRONT VALANCE, LEFT SIDE	FRONT BUMPER
DIODE—LSD6	ENGINE COMPARTMENT, LEFT FRONT CORNER	ENGINE COMPARTMENT
DIODE—LSD7	LEFT FRONT BULKHEAD	ENGINE COMPARTMENT
DIODE—LSD10	LEFT FRONT BULKHEAD	ENGINE COMPARTMENT
MAIN VALVE	LEFT FRONT BULKHEAD	ENGINE COMPARTMENT
PUMP	LEFT FRONT BULKHEAD	ENGINE COMPARTMENT
RELAY—ABS ECU (LS103)	DRIVER SIDE BLOWER HOUSING	DRIVER FOOTWELL
RELAY—MAIN (LS75)	DRIVER SIDE BLOWER HOUSING	DRIVER FOOTWELL
RELAY—PUMP (LS74)	DRIVER SIDE BLOWER HOUSING	DRIVER FOOTWELL
RESERVOIR	LEFT FRONT BULKHEAD	ENGINE COMPARTMENT
VALVE BLOCK	LEFT FRONT BULKHEAD	ENGINE COMPARTMENT
WHEEL SPEED SENSOR—FRONT	FRONT HUB CARRIER	FRONT WHEEL WELLS
WHEEL SPEED SENSOR—REAR	REAR HUB CARRIER	REAR WHEEL WELLS

CONNECTORS

CODE	DESCRIPTION	LOCATION / INTERFACE
LB127	5-WAY AMP (BLACK)	DRIVER FOOTWELL / BRAKE LIGHT SWITCH
LS1	36-WAY PMHD (BLACK)	LEFT 'A' POST, UNDER DASH PANEL / LB HARNESS
LS2	15-WAY PMHD (YELLOW)	LEFT 'A' POST, UNDER DASH PANEL / LB HARNESS
LS46	2-WAY AMP PLUG (WHITE)	ENGINE COMPARTMENT, LEFT FRONT INNER FENDER / LEFT FRONT ABS SPEED SENSOR
LS49	2-WAY AMP PLUG (WHITE)	ENGINE COMPARTMENT, RIGHT FRONT INNER FENDER / RIGHT FRONT ABS SPEED SENSOR
LS51	2-WAY AMP PLUG (WHITE)	TRUNK BULKHEAD TRIM PANEL / LEFT REAR ABS SPEED SENSOR
LS52	2-WAY AMP PLUG (WHITE)	TRUNK BULKHEAD TRIM PANEL / RIGHT REAR ABS SPEED SENSOR
LS69	55-WAY TRW (BLACK)	TRUNK, LEFT SIDE / ABS ECU
LS74	RELAY BASE (YELLOW)	DRIVER FOOTWELL / ABS PUMP RELAY
LS75	RELAY BASE (WHITE)	DRIVER FOOTWELL / ABS MAIN RELAY
LS76	5-WAY BOSCH (BLUE)	LEFT FRONT BULKHEAD / COMBINED PRESSURE SWITCH
LS77	7-WAY BOSCH (GREY)	LEFT FRONT BULKHEAD / VALVE BLOCK
LS78	5-WAY BOSCH (BLACK)	LEFT FRONT BULKHEAD / RESERVOIR FULL
LS79	2-WAY BOSCH (BLACK)	LEFT FRONT BULKHEAD / MAIN VALVE
LS80	2-WAY BOSCH (BLACK)	LEFT FRONT BULKHEAD / HYDRAULIC PUMP
LS103	RELAY BASE (BLUE)	DRIVER FOOTWELL / ABS ECU RELAY
LS104	PMS (BLACK)	LEFT SIDE OF TRUNK / NOT USED

GROUND

CODE	DESCRIPTION	LOCATION / INTERFACE
LSG56	EYELET	TRUNK TRIM PANEL, LEFT REAR / POWER GROUND
LSG118	EYELET	ENGINE COMPARTMENT, LEFT REAR / POWER GROUND

INPUTS / OUTPUTS

ANTI-LOCK BRAKING ECU

CODE	IN / OUT	CIRCUIT	ACTIVE	INACTIVE
LS69-1	OUT	POWER GROUND	GROUND	GROUND
LS69-2	OUT	OUTLET VALVE, FRONT LEFT	GROUND	12V
LS69-3	OUT	ABS ECU RELAY	12V	GROUND
LS69-4	OUT	RESERVOIR FULL SWITCH	5V	0V
LS69-18	OUT	POWER GROUND	GROUND	GROUND
LS69-20	IN	INPUT VALVE, FRONT LEFT	GROUND	12V
LS69-21	IN	OUTLET VALVE, FRONT RIGHT	GROUND	12V
LS69-23	OUT	DIAGNOSTIC SOCKET	PULSED SIGNAL	GROUND
LS69-27	OUT	WHEEL SPEED SENSOR SCREEN, RIGHT REAR	GROUND	GROUND
LS69-28	OUT	WHEEL SPEED SENSOR SCREEN, LEFT REAR	GROUND	GROUND
LS69-29	OUT	WHEEL SPEED SENSOR SCREEN, RIGHT FRONT	GROUND	GROUND
LS69-30	OUT	WHEEL SPEED SENSOR SCREEN, LEFT FRONT	GROUND	GROUND
LS69-32	IN	BRAKES APPLIED SWITCH	12V	OPEN CIRCUIT
LS69-33	IN	ABS ECU RELAY	12V	GROUND
LS69-34	IN	MAIN RELAY	GROUND	OPEN CIRCUIT
LS69-36	IN	OUTLET VALVE, REAR	GROUND	12V
LS69-38	IN	INLET VALVE, FRONT RIGHT	GROUND	12V
LS69-39	IN	MAIN VALVE	GROUND	OPEN CIRCUIT
LS69-45	IN	WHEEL SPEED SENSOR, RIGHT REAR	PULSED SIGNAL	0V
LS69-46	IN	WHEEL SPEED SENSOR, LEFT REAR	PULSED SIGNAL	0V
LS69-47	IN	WHEEL SPEED SENSOR, RIGHT FRONT	PULSED SIGNAL	0V
LS69-48	IN	WHEEL SPEED SENSOR, LEFT FRONT	PULSED SIGNAL	0V
LS69-51	IN	COMBINED PRESSURE SWITCH	5V	OPEN CIRCUIT
LS69-52	OUT	DIAGNOSTIC SOCKET	PULSED SIGNAL	OPEN CIRCUIT
LS69-53	IN	IGNITION ON	12V	OPEN CIRCUIT
LS69-54	IN	INLET VALVE, REAR	GROUND	OPEN CIRCUIT



FIG 1



FIG 2



FIG 3



FIG 4



