

TECHNICAL BULLETIN

 JAGUAR SERVICE	RECALL R469 – Hood Liner – Change of Specification – Replace	76-128
	MODEL 1994 MY XJ12 VIN 673299-708757	DATE 1/99 Amended 3/99

Remove and destroy Bulletin 76-128, dated 1/99.
Replace with this Bulletin.
Revisions are marked with a bar and in **bold text**.

ISSUE

On some 1994 MY XJ12 Sedan Models within the above VIN range, deterioration of the hood liner from excessive moisture (steam cleaning, pressure washing) can cause the sound deadening material to sag so that it can come into contact with the throttle linkage.

The liner could interfere with the throttle linkage, causing the throttle butterflies to be held off their idle stops when the accelerator pedal is released, causing an increase in the idle speed of the engine. This increase could result in an increased tendency of the vehicle to 'creep' when Drive or Reverse is selected, requiring the brakes to be more firmly applied than normal to hold the vehicle stationary.

A replacement hood liner, manufactured from a different material which is more moisture resistant, has been developed to eliminate this concern.

Jaguar will contact owners directly to advise them of this recall.

ACTION:

Install replacement hood liners, manufactured from a different material, on **all** 1994 MY XJ12 vehicles within the above VIN range at the earliest opportunity **even if the vehicle had Service Action S437 performed.**

For those vehicles originally equipped with the engine compartment light feature, this action deletes the feature. This is in the interests of reducing the possibility of water ingress to the liner, by reducing the number of openings to a minimum. You should advise the customer verbally of this, where applicable.

MODIFICATION PROCEDURE

1. Check the **underside of the hood** for an R469 authorized modification label (**Illustration 1**). If no label is found, remove the existing hood liner. Save the screw fasteners for reuse. On vehicles equipped with twin engine compartment lamps, unclip the lamps and disconnect them at the adjacent multiplug connector. The lamps can be discarded. Ensure that the unused harnesses remain attached to their support clips, to avoid rattles. If a clip is missing and a replacement is not available, wrap the multiplug connectors with soft foam, secured by adhesive tape, so that they will be held against the metal by the replacement liner.
2. Peel off the protective backing from the replacement hazard warning label.
3. Carefully align the label with the aluminum foil patch on the replacement liner and adhere the label to the foil.

4. Position the replacement hood liner. Temporarily retain it in its correct position by installing 4 or 5 of the screw fasteners. Ensure that the liner is aligned with **all** existing fastener points - adjust if necessary.

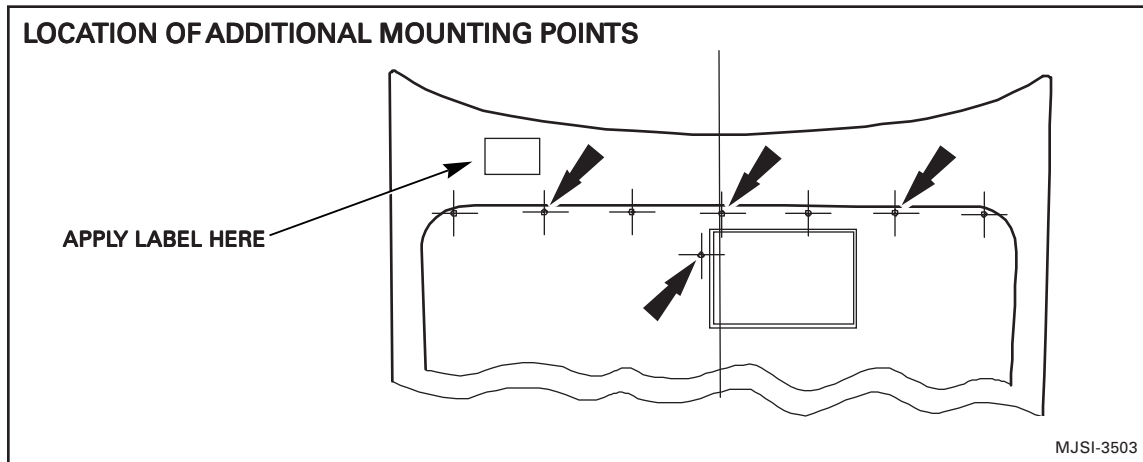

ILLUSTRATION 1

5. Refer to Illustration 1 for the location of the 4 **additional** fasteners.
6. Use a scribe to mark through the locations of the **additional** fastener points on the ribs of the hood reinforcement panel.
7. Remove the replacement liner. Temporarily place the old liner over the engine, to catch any drill chips from the following operations.
8. Center punch the reinforcement panel at the centers of the locations marked in step 6 above. Check that the locations line up approximately with the centers of the raised ribs of the reinforcement panel.

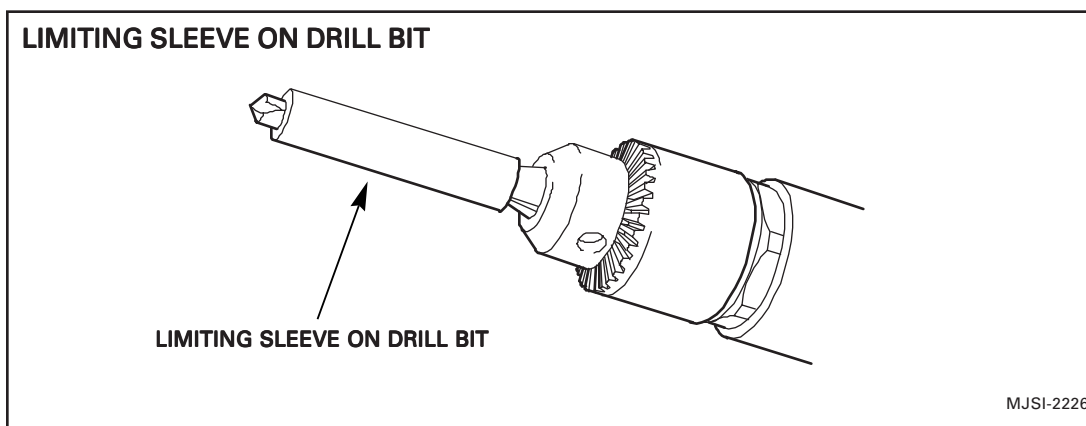

ILLUSTRATION 2

9. Use a drill equipped with a plastic or rubber sleeve (Illustration 2) to act as a stop so that the drill bit will not penetrate **more than 5 mm (3/16 inch)**, to drill a pilot hole at each of the 4 locations.

⚠ Caution: Careless drilling that allows excessive penetration of the drill bit can result in serious cosmetic damage to the outer panel of the hood.

10. Enlarge the 4 holes to 6.35 mm diameter (1/4 inch) using a drill bit similarly fitted with a depth limiting sleeve.
11. Clean away all chips from the drilling operations. Remove the old liner from covering the engine.
12. Use zinc-rich paint to treat all bare metal that was exposed by drilling.
13. Check the condition of all existing liner fasteners. Replace any which are not in good condition. Obtain 4 **additional** fasteners, along with replacements for any fasteners that were missing or damaged, if any.
14. Align the hood liner with the hood reinforcement frame.
15. Insert and tighten **all** fasteners, including the additional 4 fasteners. Ensure that the replacement liner is completely in contact with the reinforcement frame at all fastener points.
16. Carefully lower the hood towards the 'closed' position, checking as far as possible that the liner does **NOT** contact the throttle pedestal or other linkages of the throttle mechanism.
17. Partially raise and then completely close the hood, ensuring that it is completely latched.
18. Actuate the accelerator pedal several times through its full travel, to check for free movement and that the pedal returns completely to the idling position.
19. Start the engine and check that the engine settles at its normal idle speed. Check that it returns normally to idling speed when the pedal is released after having run at 2000 rpm for a few seconds.
20. Briefly accelerate hard, then immediately release the pedal, repeating this action three times to cause the engine to move as much as possible on its mounts. **Do NOT exceed 4000 rpm during this action.** Switch off the engine.

Note: If the engine does not return immediately to normal idle speed when the accelerator pedal is released, **INVESTIGATE AND REPAIR this condition.** If a defect exists in the throttle mechanism, repair of this condition is **NOT** covered by this recall action, and is chargeable to the customer. **In this case, contact the customer and obtain prior authority for you to perform the necessary repair at customer expense.**

21. Open the hood and check in the area at the lower left-hand of the hazard warning label. Make sure that there is no witness mark from the liner having contacted the throttle pedestal or mechanism during the previous operations.

22. If there is no sign of contact between the liner and throttle pedestal or mechanism, close the hood and remove the fender covers.
23. **Write the date and your dealer number on the R469 authorized modification label (Illustration 3).** Apply the label to the underside of the hood as shown in Illustration 1. (This label will immediately indicate to any other dealer that the vehicle concerned has already been rectified).

AUTHORIZED MODIFICATION LABEL



AUTHORIZED MODIFICATIONS

THE FOLLOWING MODIFICATIONS HAVE BEEN MADE:

R469 UNDERHOOD LINER

THESE MODIFICATIONS HAVE BEEN APPROVED,
AS APPROPRIATE, BY THE EPA, CARB, OR NHTSA.

DEALER NUMBER: 	DATE:
-------------------------------------------------------------------------------------------------------	----------------------------------------------------------------------------------------------

CHANGE AUTHORITY: SAFETY RECALL R469
JAGUAR PLC CAMPAIGN PRINTED IN U.S.A.

WRITE IN DEALER NUMBER →

← WRITE IN DATE

ILLUSTRATION 3

PARTS INFORMATION:

<u>DESCRIPTION</u>	<u>PART NUMBER</u>	<u>QTY</u>
Hood liner (R469 only)	GMB 9340AB/K	1
Label, Hazard Warning	MMD 7700DB	1
Label, Authorized Modification	JAG469/STKR	1
Plastic screw fastener	KRS 113130	A/R*

* package contains 10 fasteners.

Warranty Information:

RECALL R469

<u>VEHICLE</u>	<u>SUMMARY CODE</u>	<u>R.O. NUMBER</u>	<u>DESCRIPTION</u>	<u>TIME ALLOWANCE</u>
XJ12 1994 MY	TF	76.93.60	Replace hood liner (R469 only)	0.65 hrs.
Model code 2111		10.10.10	Drive in/drive out	0.15 hrs.

<u>Qty</u>	<u>Part #</u>	<u>Description</u>
1	GMB 9340AB/K	Hood liner
1	MMD 7700DB	Label, Hazard Warning
6	KRS 113130	Plastic screw fastener

NOTE: Always perform a DCS claim search first to determine whether this recall has been performed on this vehicle. The warranty selection under the vehicle inquiry will give a listing of all claims against the vehicle. If R469 appears in the fault code field, do not perform this recall.

CLAIM SUBMISSION PROCEDURE:

Warranty summary codes have been assigned to this service action in order to simplify claim submission. The dealership will be reimbursed the parts and labor time allowance as indicated.

DCS DEALERS

Submit claims using the appropriate summary code for the vehicle model and work performed. Follow standard campaign submission procedures.

NON-DCS DEALERS

Submit claims on the Recall Campaign Summary form W-25. Enter the appropriate summary code for the vehicle model and work performed in the Repair Code column. Do not use the W-1 warranty claim form.