

WINDSCREEN WIPER CIRCUIT

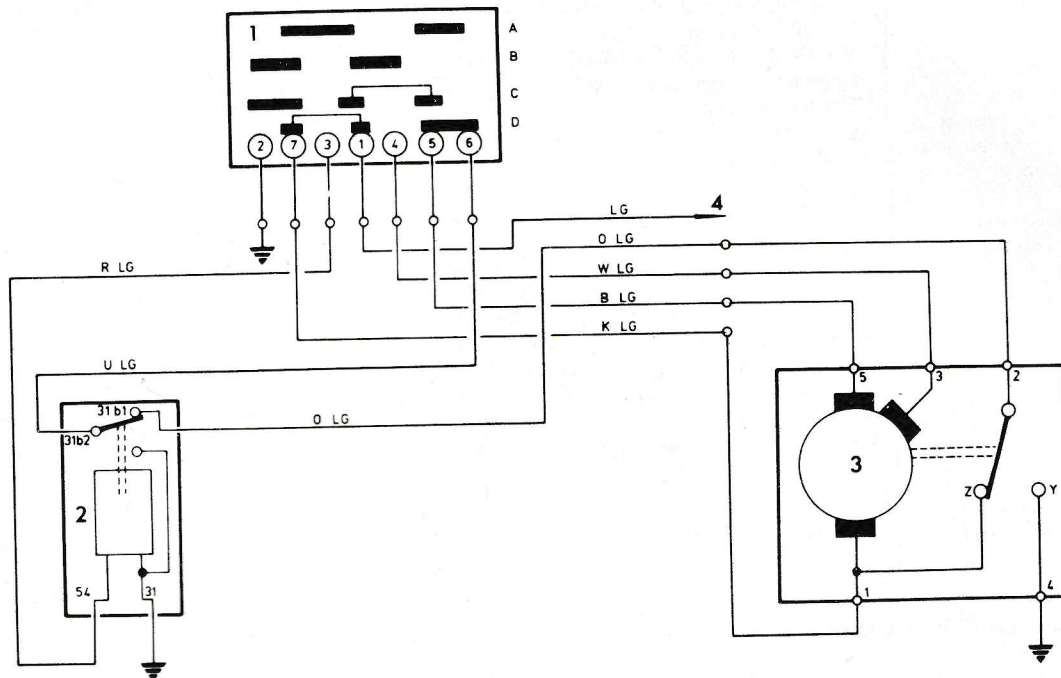

KEY TO DIAGRAM

1. Control switch
2. Delay unit
3. Wiper motor
4. To fuse No 9

Switch Positions

- A Intermediate/Flick wipe
- B Fast wipe
- C Slow wipe
- D Off

Park Switch Position

- Z Park
- Y Run

Fig. 14

WINDSCREEN WIPERS

DESCRIPTION

The following description of the Windscreen Wiper Operation should be studied with the accompanying circuit diagram.

OFF The Load Relay is energised by selection of 'IGN ON' and applies 12 volts through fuse 7 to the terminal 1 on the wiper switch. 12 volts is internally fed via the wiper switch contacts to terminal 7 and from there passes to terminal 1 on the Wiper Motor. This applies 12 volts to one side of the motor winding and, via the closed 'PARK' switch to the closed contacts of the Wiper Timer at terminal 31 b1. Terminal 31 b2 of the timer passes the 12 volts via terminal 6 of the switch and internal connection to terminal 5. From terminal 5 the 12 volt supply is applied to terminal 5 on the motor and thereby the opposite brush to terminal 1, completely stalling the motor.

SLOW The 12 volts on terminal 1 of the switch is applied to terminal 5 and to terminal 5 on the wiper motor. An earth connection to terminal 2 on the switch is internally applied to terminal 7 and thereby to terminal 1 on the motor. The motor then runs in a forward direction at a slow speed.

FAST The earth connection detailed in 'SLOW' is maintained but the 12 volt supply is moved via terminal 4 on the switch and terminal 3 on the motor to the high speed brush. The motor then runs in a forward direction at a high speed.

OFF When 'OFF' is selected the 'RUN' position of the Park/Run contact in the motor applies an earth at connection 4 of the motor via connection 2 and the timer contacts to position 6 on the switch. Then via the internal connection to 5 on the switch applying the

earth to terminal 5 on the motor and the brush previously supplied with 12 volts. The motor therefore stops. Meanwhile 12 volts is applied to the previously earthed motor contact 1 via switch contacts 1 and 7; the motor therefore immediately stops the sweep and runs in a reverse direction to the limit of its travel. At that point the internal Park/Run switch moves to the 'PARK' position, removes the earth at 4 and applies 12 volts via the timer contact to the opposite brush. The motor instantly stalls.

Single Sweep Operation

When this position is selected and released, 12 volts are applied both to the coil of the timer unit, operating its contact, and to the terminal 1 on the motor. An earth is applied to the opposite brush of the motor, terminal 5 via the timer contact 31 b2 and an internal connection to terminal 31. The motor therefore starts and runs in a reverse direction. As the supply to the timer is applied then instantly removed the contacts operate then relax to the 'AT REST' position. The motor earth on the brush of terminal 5 is then achieved through the Park/Run contacts at the 'RUN' position until the motor reaches the end of the sweep. The Park/Run switch then returns to the PARK position, applying 12 volts to brush 5 as previously described. The motor therefore stalls.

Intermittent Operation

When position 'D' is selected 12 volts are applied to the operating coil of the timer and simultaneously to terminal 1 of the wiper motor. Terminal 5 of the wiper motor is connected via terminal 5 and 6 of the switch to the timer contact 31 b2(1). When 12 volts are applied to the timer its operation consists of an instantaneous 'flip flop' then a delay of approximately 5 seconds and another 'flip flop'.

This action applies instantaneous earth to terminal 5 of the motor, starting it running in a reverse direction. The motor then obtains its own earth via the Park/Run contact at 'RUN' to sustain it for one sweep. As the motor is running in a reverse direction, the 'PARK' switch closes at the end of the sweep and applies 12 volts via the new closed contacts of the Timer to the opposite brush to stall the motor in the 'PARK' position.

After approximately 5 seconds the Timer again 'flip flops' removing the 12 volts from the motor brush at 5 and replaces it with an earth. The cycle already described then repeats itself until the Wiper Switch is restored to the 'OFF' position cancelling the operation of the timer contacts. The motor then stalls as previously described.

Fault Finding

Check the fuse and all connections ensuring the earth connections are clean and tight.

With the ignition switched on battery voltage should be obtained at terminals 1, 2 and 5 of the wiper motor. Battery voltage should also be obtained at terminals 31 b1 and 31 b2 on the delay unit. With the wiper switch in the slow run position and the ignition switched on battery voltage should be obtained at terminal 5 of the wiper motor. The wiper motor earth circuit is via terminals 7 and 2 of the wiper switch. In the fast run position battery voltage should be obtained at terminal 3 of the wiper motor. The earth circuit is the same as the slow run position.

In the intermittent wipe position battery voltage should be obtained at terminal 1 of the wiper motor and terminal 54 on the delay unit. The earth is switched intermittently via the delay unit and the Park/Run switch in the wiper motor.