

Vehicle recovery

EMERGENCY PARK RELEASE (EPR)

When recovering your vehicle, it is essential that the EPR is operated. EPR prevents the transmission from automatically selecting **P**, ensuring that the transmission remains in neutral (**N**). EPR is operated by a lever located beneath a trim panel in the cubby box. Before activating EPR, select **P**, apply the parking brake and turn the ignition off.

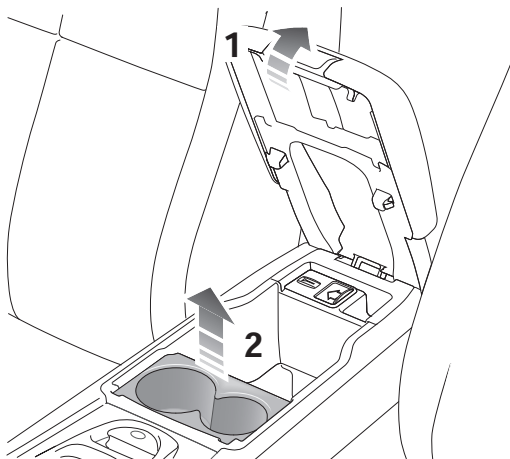

JAG1426

1. Open the cubby box lid.
2. Remove the twin cup holder.
3. Using an appropriate screwdriver, unscrew and remove the screw securing the trim panel, where shown. Store the screw in a safe place.

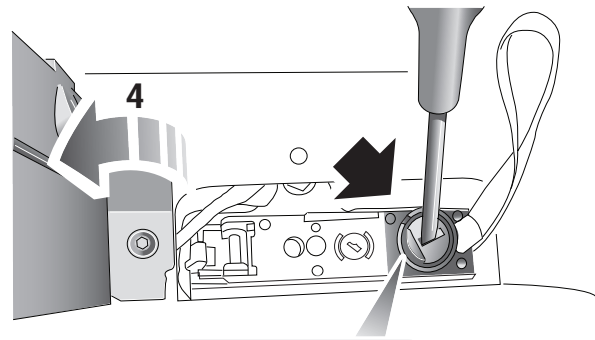
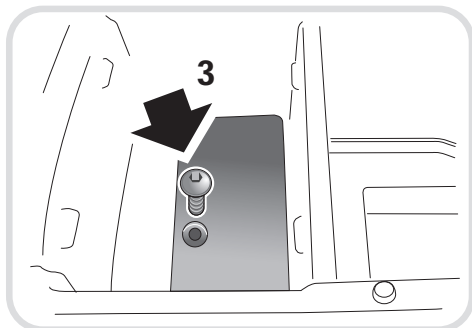

JAG1427

4. Lift the right-hand edge of the trim panel to open.
5. Using a flat-bladed screwdriver, turn the locking device 90° counter-clockwise.

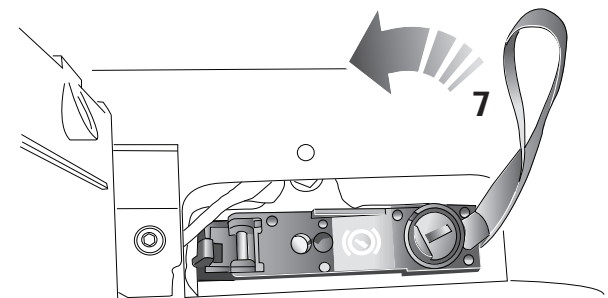
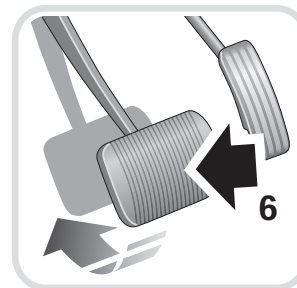
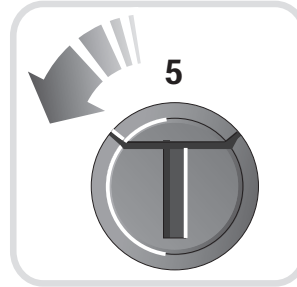

JAG1428

6. Apply the foot brake.
7. Use the strap to pull the EPR lever upwards, until it latches in the vertical position.

Vehicle recovery

When the EPR is activated, the JaguarDrive selector will remain in **P**, but the selector indicator and the gear display in the message center will both flash **N** (if ignition is on), to indicate that EPR is active.

Cancelling EPR

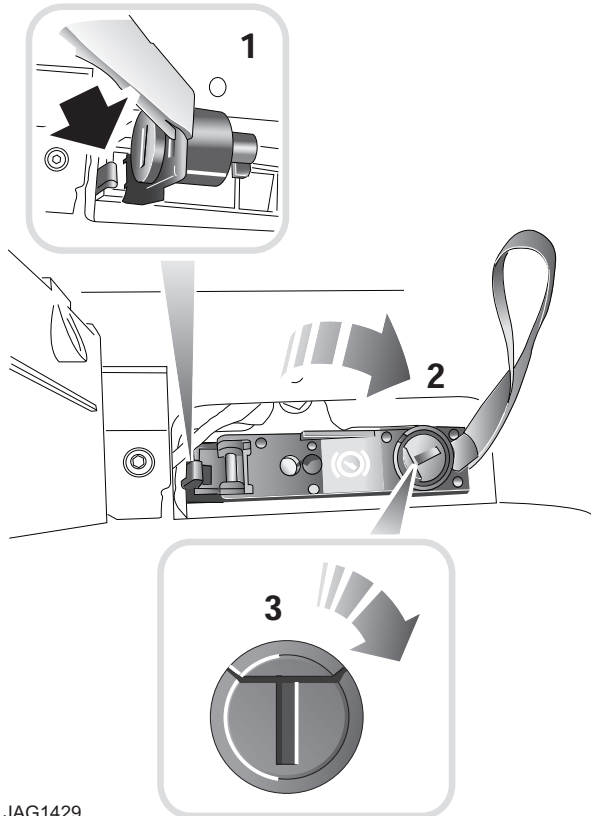

JAG1429

1. Using a flat-bladed screwdriver, release the latch (arrowed).
2. Return the EPR lever to its horizontal position.
3. Turn the locking device 90° clockwise to secure.

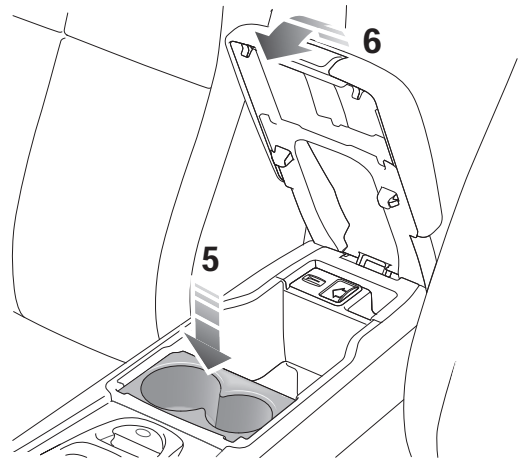
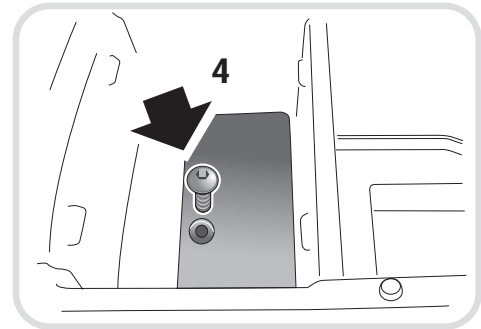

JAG1430

4. Lower the trim panel and secure with the screw.
5. Replace the twin cup holder.
6. Close the cubby box.