

BRAKES

Mechanical Brake System

XKR models use Teves-supplied 'R' performance brakes with non cross-drilled rotors, as used on the 2007 XJR (X350) and S-TYPE R (X206) models. The cast iron 2-piston caliper is painted black and features the Jaguar 'R' logo. Front brake disc diameter is increased from 326 mm on non-'R' variants to 355 mm; front disc thickness increases from 30mm to 32mm. The ventilated brake disc is manufactured from cast iron.

NOTE: There is no wear indicator installed for the front brake pads.

'R' Performance Brake Caliper



Alcon High-Performance Brake System (Special Edition models only)

A new high-performance brake system will be available on future special-edition XKR models. This brake system, manufactured by Alcon, is a racing-derived brake system featuring the following:

- Crescent-grooved brake discs
- 6-piston front calipers
- 4-piston rear calipers
- Standard 2007 MY XK (X150) rear knuckle
- Brembo parking brake caliper (as used on 2004 MY XJR and S-TYPE R)

Alcon Brake Discs

The Alcon brake discs are high-performance ventilated discs made of cast iron. These discs are ‘handed’ and cannot be swapped from side to side (left to right). The discs have a diameter of 350mm and a thickness of 45mm.

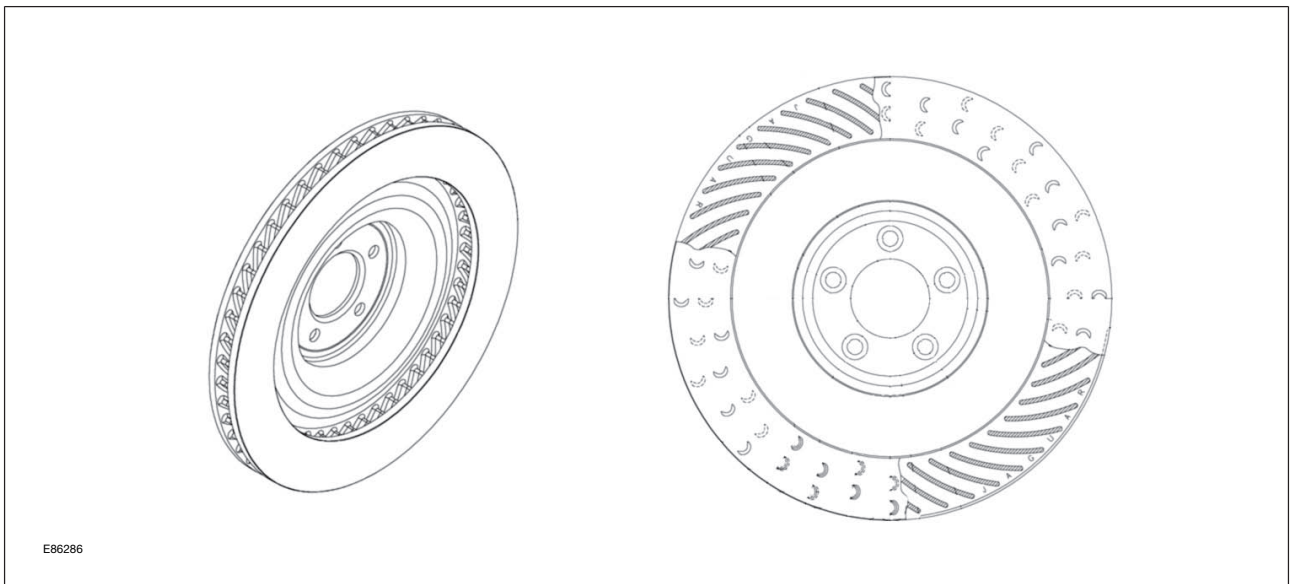

Alcon Brake Calipers

The Alcon Monobloc calipers are non-handed except for the installation of the pipe assemblies, bleed nipples and dust caps. The front calipers have 6 pistons, while the rear calipers have 4. The calipers are painted red with the ‘R’ logo painted on the top surface.

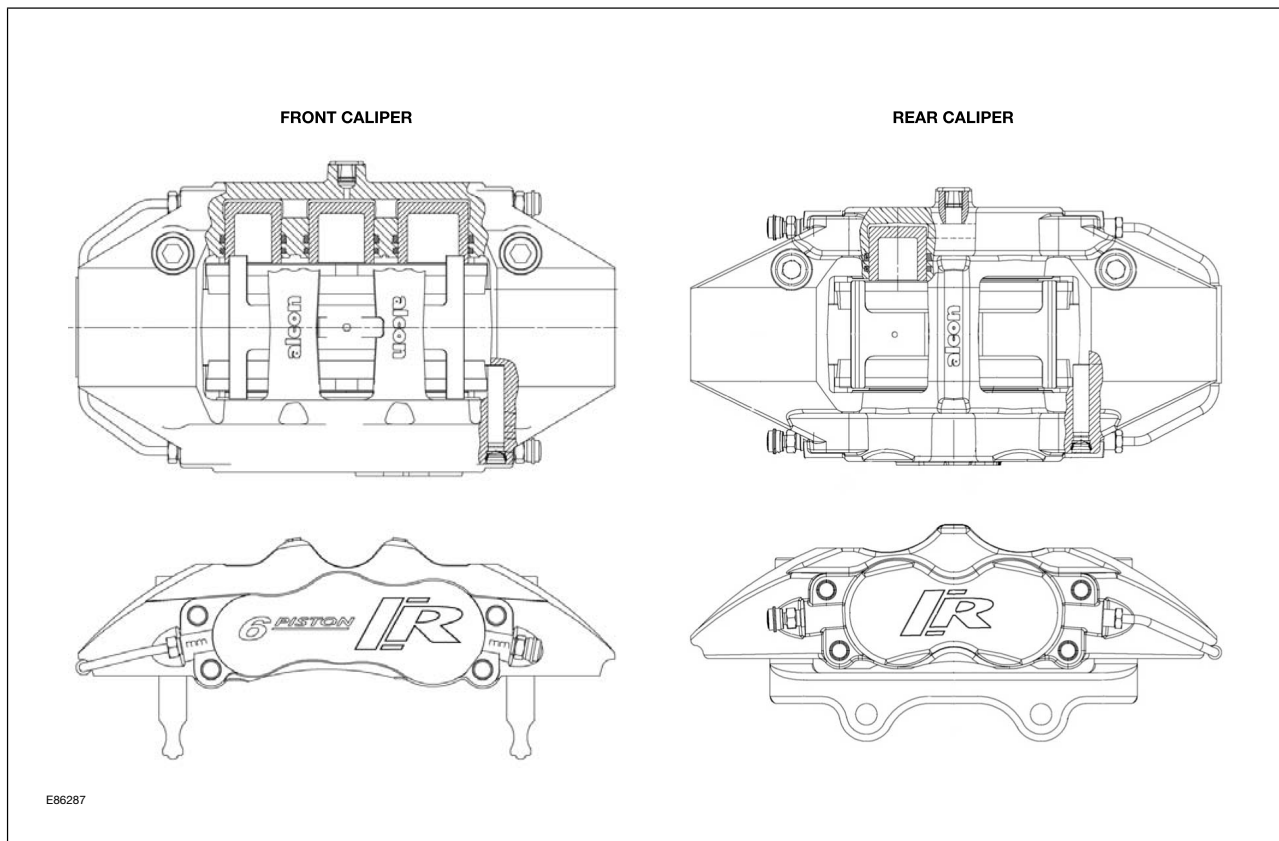

Rear Brakes

The rear brakes on models fitted with the Alcon brake pack use the standard XK N/A knuckle, and are fitted with separate emergency brake calipers (as on 2003 – 2004 MY XJR and S-TYPE R models).