

Vehicle Specifications

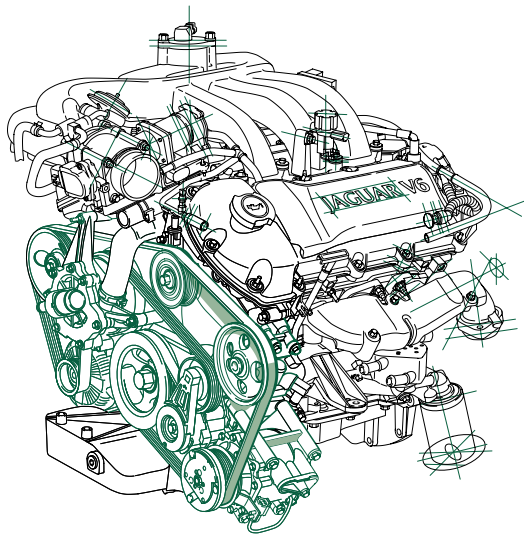

09/2003



Using correct and up-to-date technical data and specifications when servicing Jaguar Vehicles is important to ensure a safe and trouble free operation.

This booklet is produced to assist Jaguar Service Technicians in their task of providing first class repairs and service to Jaguar Vehicles. Enabling them to achieve the high standard of workmanship customers expect from Jaguar Dealers.

The date printed on the front cover is the issue date of the booklet. The booklet will be updated and reissued periodically to enable the inclusion of new and modified data.

In between these updates we recommend that information issued in publications, such as Technical Service Bulletins, which supersedes the information issued here should be entered by hand into this booklet.

SECTION	PAGE
Vehicle Identification Numbers (VIN)	1
Location of Powertrain Identification Codes	3
Engine Data	8
Engine Cylinder Numbering and Firing Order	13
Engine Valve Clearances	16
Spark Plug Specification	17
Engine Oil – Specification and Capacity	21
Rear Axle Differential Ratio	34
Transmission and Differential Lubricants – Specification and Capacity	38
Engine Coolant – Specification and Capacity	42
Air Conditioning – Specification and Capacity	46
Power Steering Fluid – Specification and Capacity	47
Tire Specification (Original Equipment)	51
Tire Specification (Winter)	57
Tire Pressures (Original Equipment)	59
Tire Pressures (Winter)	68
Vehicle Ride Heights	69
Wheel Alignment – Front	75
Wheel Alignment – Rear	89
Tightening Torques – Wheel Nuts	95
Tightening Torques – V8 Engine Components	96
Tightening Torques – V6 Engine Components	100
Tightening Torques – 2.0 Liter Diesel Engine Components	106
Tightening Torques and Sequence – Cylinder Heads	109
Tightening Torques and Sequence – Intake and Exhaust Manifolds	112
Accessory Drive Belt Installation	117

Vehicle Identification Number

Notes

It is essential that the vehicle identification number (VIN) is quoted when ordering parts, and in all associated correspondence.

XJ

Up to 2003.5 MY: Dependent upon market, the VIN and other information are displayed on a label located either on the rear edge of the left-hand front door or on the body front-upper crossmember. The VIN stamping is located on the right-hand-side of the luggage compartment and a quick reference plate is visible through the left-hand lower corner of the windshield.

2003.5 MY onwards: The VIN and other information are displayed on a label located on left-hand "A" pillar. The VIN stamping is located on the right-hand-side of the luggage compartment and a quick reference plate is visible through the left-hand lower corner of the windshield.

XK

The VIN and other information are displayed on a label located on the left-hand "B" pillar above the door striker plate. The VIN stamping is located on the right-hand-side of the luggage compartment and a quick reference plate is visible through the left-hand lower corner of the windshield.

S-TYPE

The VIN and other information are displayed on a label located on left-hand "A" pillar. The VIN stamping is located on the right-hand-side of the luggage compartment and a quick reference plate is visible through the left-hand lower corner of the windshield.

X-TYPE

The VIN and other information are displayed on a label, located on:

- early vehicles, the left-hand "A" pillar,
- later vehicles, bottom of the left-hand "B" pillar.

The VIN stamping is located on the right-hand-side of the luggage compartment and a quick reference plate is visible through the left-hand lower corner of the windshield.

Model Year	VIN	
	From	To
XJ		
1998	812317	853935
1999	853936	878717
2000	F00103	F20644
2001	F20645	F41862
2002	F41863	F59525
2003.5	G00442	Current
XK		
1997	001246	018107
1998	018108	024686
1998.75	024687	031302
1999	031303	042775
2000	A00116	A11139
2001	A11140	A24195
2002	A24196	A30644
2003	A30645	Current

Model Year	VIN	
	From	To
S-TYPE		
1999.25	L00600	L31320
2000	L31321	L52822
2000.5	L52823	L86901
2001	L86902	M45254
2002.5	M45255	M62935
2003	M62936	Current
X-TYPE		
2001.5	C00344	C59260
2002.25 *	C59261	D55321
2004.25 **	D55322	Current

Notes

* Introduction of 2.0 liter Gasoline X-TYPE

** Introduction of 2.0 liter Diesel X-TYPE

V8 – Engine Identification Codes

Notes

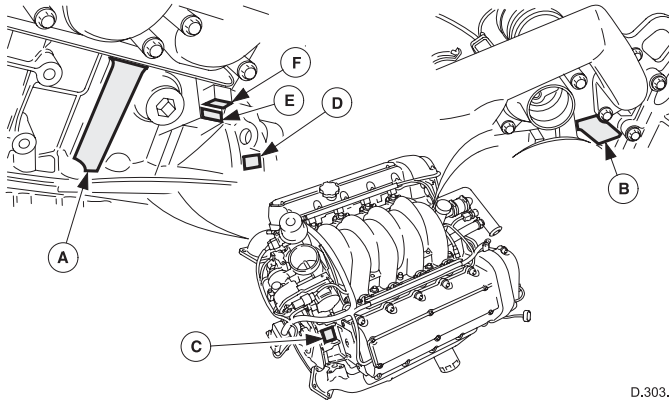

D.303.1697

- A Engine Technical Data, also Serial Number from 2001 MY
- B Serial Number up to 2001 MY
- C Emission Code XJ and XK
- D S-TYPE Emission Code, primary position (up to VIN M51309)
- E S-TYPE Emission Code, primary position (VIN M51310 onwards), also XJ 2003.5 MY
- F S-TYPE Emission Code, secondary position for amended codes, also XJ 2003.5 MY

V6 (S-TYPE and XJ) Engine Identification Codes

Notes

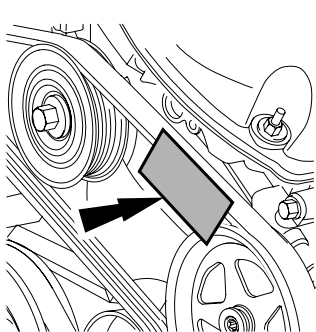

Engine Identification Code

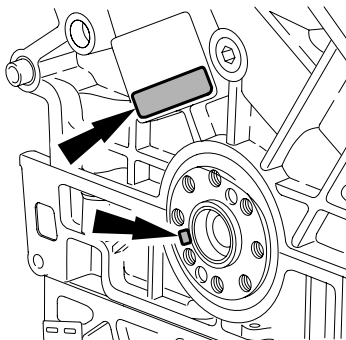

Mains Bearing Selection Codes

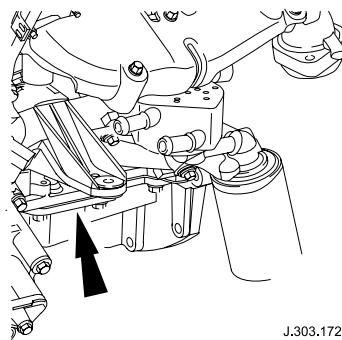

J.303.1729

Serial Number and Emission Code

V6 (X-TYPE) Engine Identification Codes

Notes

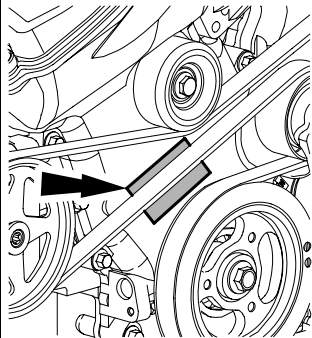

Engine Identification Code

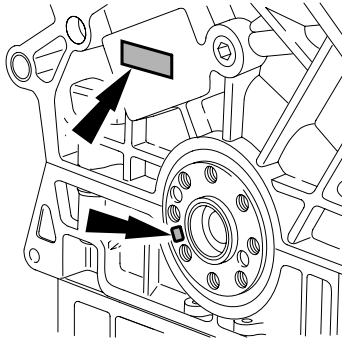

Mains Bearing Selection Codes

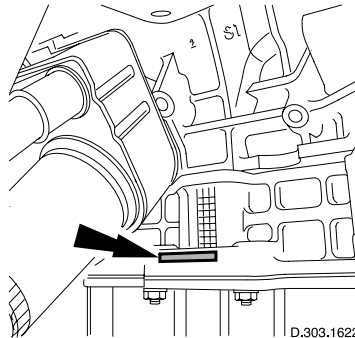

Serial Number and Emission Code

D.303.1622

2.0 Liter Diesel X-TYPE Engine Identification Codes

Notes

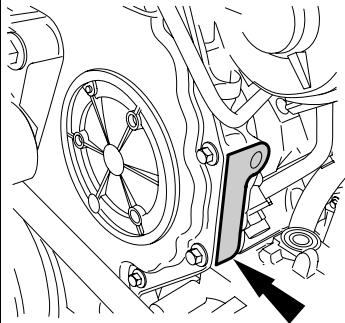

Serial Number and Emission Code

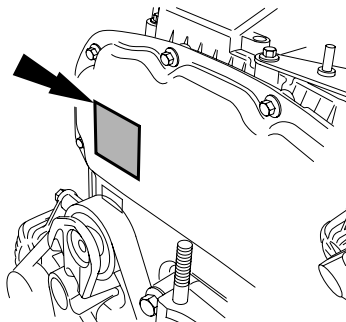

Engine Identification Code

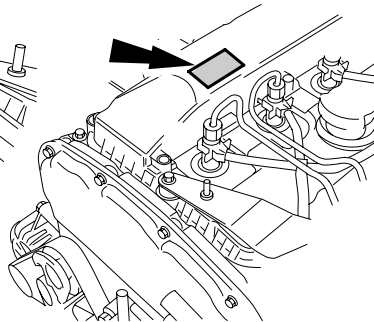

Fuel Injector Codes

303.1754

All Vehicles: Transmission and Final Drive Identification Codes

Notes

Transmission: the serial numbers are either stamped on the casing, or displayed on a metal plate or bar-code label attached to the casing.

Final drive unit: serial numbers are either stamped on the casing, or displayed on a metal label or bar-code label attached to the units casing.

Model/ Engine	Engine Capacity	Engine Description	Max. Engine Torque (DIN)	Max. Engine Power (DIN)	Max. Engine Torque (EC and SAE)	Max. Engine Power (EC and SAE)	Comp. Ratio	Bore	Stroke
XJ: 1998 up to 2003.5 MY – VIN From 812317 To F59525									
3.2 liter	3248 cm ³ (198.2 in ³)	90° “Vee” 8 Cylinder 32 Valves	316 Nm / 233 lb ft at 4350 RPM	240 BHP / 179 kW / 243 PS at 6350 RPM	310 Nm / 228 lb ft at 4350 RPM	233 BHP / 174 kW / 237 PS at 6350 RPM	10.5 : 1 ± 0.5 : 1	86.0 mm (3.386 in)	70.0 mm (2.756 in)
4.0 liter	3996 cm ³ (244 in ³)	90° “Vee” 8 Cylinder 32 Valves	393 Nm / 290 lb ft at 4250 RPM	290 BHP / 216 kW / 294 PS at 6100 RPM	375 Nm / 276 lb ft at 4250 RPM	280 BHP / 209 kW / 284 PS at 6100 RPM	10.75 : 1 ± 0.5 : 1	86.0 mm (3.386 in)	86.0 mm (3.386 in)
4.0 liter – supercharged	3996 cm ³ (244 in ³)	90° “Vee” 8 Cylinder 32 Valves	525 Nm / 387 lb ft at 3600 RPM	370 BHP / 276 kW / 375 PS at 6150 RPM	505 Nm / 372 lb ft at 3600 RPM	358 BHP / 267 kW / 363 PS at 6150 RPM	8.9 : 1 ± 0.5 : 1	86.0 mm (3.386 in)	86.0 mm (3.386 in)

Notes

Model/ Engine	Engine Capacity	Engine Description	Max. Engine Torque (DIN)	Max. Engine Power (DIN)	Max. Engine Torque (EC and SAE)	Max. Engine Power (EC and SAE)	Comp. Ratio	Bore	Stroke
XJ: 2003.5 MY onwards – VIN From G00442 To Current									
3.0 liter	2967 cm ³ (181 in ³)	60° “Vee” 6 Cylinder 24 Valves	300 Nm / 221 lb ft at 4100 RPM	240 BHP / 179 kW / 243 PS at 6800 RPM	293 Nm / 216 lb ft at 4100 RPM	235 BHP / 175 kW / 238 PS at 6800 RPM	10.5 : 1 ± 0.5 : 1	89.0 mm (3.504 in)	79.5 mm (3.130 in)
3.5 liter	3555 cm ³ (216 in ³)	90° “Vee” 8 Cylinder 32 Valves	345 Nm / 254 lb ft at 4200 RPM	262 BHP / 196 kW / 266 PS at 6250 RPM	335.2 Nm / 262 lb ft at 4200 RPM	255 BHP / 190 kW / 258 PS at 6250 RPM	11.0 : 1 ± 0.5 : 1	86.0 mm (3.386 in)	76.5 mm (3.011 in)
4.2 liter	4196 cm ³ (256 in ³)	90° “Vee” 8 Cylinder 32 Valves	420 Nm / 310 lb ft at 4100 RPM	300 BHP / 224 kW / 304 PS at 6000 RPM	410.8 Nm / 303 lb ft at 4100 RPM	293.5 BHP / 218.9 kW / 298 PS at 6000 RPM	11.0 : 1 ± 0.5 : 1	86.0 mm (3.386 in)	90.3 mm (3.555 in)
4.2 liter – supercharged	4196 cm ³ (256 in ³)	90° “Vee” 8 Cylinder 32 Valves	553 Nm / 408 lb ft at 3500 RPM	400 BHP / 298 kW / 406 PS at 6100 RPM	541.4 Nm / 399 lb ft at 3500 RPM	390 BHP / 290.8 kW / 395 PS at 6100 RPM	9.1 : 1 ± 0.5 : 1	86.0 mm (3.386 in)	90.3 mm (3.555 in)

Notes

Model/ Engine	Engine Capacity	Engine Description	Max. Engine Torque (DIN)	Max. Engine Power (DIN)	Max. Engine Torque (EC and SAE)	Max. Engine Power (EC and SAE)	Comp. Ratio	Bore	Stroke
XK: 1997 up to 1998.75 MY – VIN From 001246 To 024686									
4.0 liter	3996 cm ³ (244 in ³)	90° “Vee” 8 Cylinder 32 Valves	393 Nm / 290 lb ft at 4250 RPM	290 BHP / 216 kW / 294 PS at 6100 RPM	375 Nm / 276 lb ft at 4250 RPM	280 BHP / 209 kW / 284 PS at 6100 RPM	10.75 : 1 ± 0.5 : 1	86.0 mm (3.386 in)	86.0 mm (3.386 in)
XK: 1998.75 up to 2003 MY – VIN From 024687 To A30644									
4.0 liter	3996 cm ³ (244 in ³)	90° “Vee” 8 Cylinder 32 Valves	393 Nm / 290 lb ft at 4250 RPM	290 BHP / 216 kW / 294 PS at 6100 RPM	375 Nm / 276 lb ft at 4250 RPM	280 BHP / 209 kW / 284 PS at 6100 RPM	10.75 : 1 ± 0.5 : 1	86.0 mm (3.386 in)	86.0 mm (3.386 in)
4.0 liter – supercharged	3996 cm ³ (244 in ³)	90° “Vee” 8 Cylinder 32 Valves	525 Nm / 387 lb ft at 3600 RPM	370 BHP / 276 kW / 375 PS at 6150 RPM	505 Nm / 372 lb ft at 3600 RPM	358 BHP / 267 kW / 363 PS at 6150 RPM	8.9 : 1 ± 0.5 : 1	86.0 mm (3.386 in)	86.0 mm (3.386 in)
XK: 2003 MY onwards – VIN From A30645 To Current									
4.2 liter	4196 cm ³ (256 in ³)	90° “Vee” 8 Cylinder 32 Valves	420 Nm / 310 lb ft at 4100 RPM	300 BHP / 224 kW / 304 PS at 6000 RPM	410.8 Nm / 303 lb ft at 4100 RPM	293.5 BHP / 218.9 kW / 298 PS at 6000 RPM	11.0 : 1 ± 0.5 : 1	86.0 mm (3.386 in)	90.3 mm (3.555 in)
4.2 liter – supercharged	4196 cm ³ (256 in ³)	90° “Vee” 8 Cylinder 32 Valves	553 Nm / 408 lb ft at 3500 RPM	400 BHP / 298 kW / 406 PS at 6100 RPM	541.4 Nm / 399 lb ft at 3500 RPM	390 BHP / 290.8 kW / 395 PS at 6100 RPM	9.1 : 1 ± 0.5 : 1	86.0 mm (3.386 in)	90.3 mm (3.555 in)

Notes

Model/ Engine	Engine Capacity	Engine Description	Max. Engine Torque (DIN)	Max. Engine Power (DIN)	Max. Engine Torque (EC and SAE)	Max. Engine Power (EC and SAE)	Comp. Ratio	Bore	Stroke
S-TYPE: 1999.25 up to 2002.5 MY – VIN From L00600 To M45254									
3.0 liter	2967 cm ³ (181 in ³)	60° “Vee” 6 Cylinder 24 Valves	300 Nm / 221 lb ft at 4500 RPM	240 BHP / 179 kW / 243 PS at 6800 RPM	293 Nm / 216 lb ft at 4500 RPM	235 BHP / 175 kW / 238 PS at 6800 RPM	10.5 : 1 ± 0.5 : 1	89.0 mm (3.504 in)	79.5 mm (3.130 in)
4.0 liter	3996 cm ³ (244 in ³)	90° “Vee” 8 Cylinder 32 Valves	390 Nm / 287 lb ft at 4300 RPM	281 BHP / 209 kW / 284 PS at 6100 RPM	378 Nm / 279 lb ft at 4300 RPM	272 BHP / 203 kW / 276 PS at 6100 RPM	10.75 : 1 ± 0.5 : 1	86.0 mm (3.386 in)	86.0 mm (3.386 in)
S-TYPE: 2002.5 MY onwards – VIN From M45255 To Current									
2.5 liter	2497 cm ³ (152 in ³)	60° “Vee” 6 Cylinder 24 Valves	250 Nm / 184 lb ft at 4000 RPM	201 BHP / 150 kW / 204 PS at 6800 RPM	245 Nm / 181 lb ft at 4000 RPM	197 BHP / 147 kW / 200 PS at 6800 RPM	10.30 : 1 ± 0.35 : 1	81.65 mm (3.214 in)	79.5 mm (3.129 in)
3.0 liter	2967 cm ³ (181 in ³)	60° “Vee” 6 Cylinder 24 Valves	300 Nm / 221 lb ft at 4100 RPM	240 BHP / 179 kW / 243 PS at 6800 RPM	293 Nm / 216 lb ft at 4100 RPM	235 BHP / 175 kW / 238 PS at 6800 RPM	10.5 : 1 ± 0.5 : 1	89.0 mm (3.504 in)	79.5 mm (3.130 in)
4.2 liter	4196 cm ³ (256 in ³)	90° “Vee” 8 Cylinder 32 Valves	420 Nm / 310 lb ft at 4100 RPM	300 BHP / 224 kW / 304 PS at 6000 RPM	410.8 Nm / 303 lb ft at 4100 RPM	293.5 BHP / 218.9 kW / 298 PS at 6000 RPM	11.0 : 1 ± 0.5 : 1	86.0 mm (3.386 in)	90.3 mm (3.555 in)
4.2 liter – supercharged	4196 cm ³ (256 in ³)	90° “Vee” 8 Cylinder 32 Valves	553 Nm / 408 lb ft at 3500 RPM	400 BHP / 298 kW / 406 PS at 6100 RPM	541.4 Nm / 399 lb ft at 3500 RPM	390 BHP / 290.8 kW / 395 PS at 6100 RPM	9.1 : 1 ± 0.5 : 1	86.0 mm (3.386 in)	90.3 mm (3.555 in)

Notes

Model/ Engine	Engine Capacity	Engine Description	Max. Engine Torque (DIN)	Max. Engine Power (DIN)	Max. Engine Torque (EC and SAE)	Max. Engine Power (EC and SAE)	Comp. Ratio	Bore	Stroke
X-TYPE: 2001.5 MY onwards – VIN From C00344 To Current									
2.0 liter Gasoline	2099 cm ³ (128 in ³)	60° “Vee” 6 Cylinder 24 Valves	200 Nm / 148 lb ft at 4100 RPM	157 BHP / 117 kW / 159 PS at 6800 RPM	196 Nm / 145 lb ft at 4100 RPM	154 BHP / 114.6 kW / 156 PS at 6800 RPM	10.75 : 1 ± 0.5 : 1	81.65 mm (3.214 in)	66.84 mm (2.631 in)
2.0 liter Diesel	1998 cm ³ (122 in ³)	Inline 4 Cylinder 16 Valves	331 Nm / 244 lb ft at 1800 RPM	128 BHP / 96 kW / 129 PS at 3800 RPM	330 Nm / 243 lb ft at 1800 RPM	129 BHP / 96 kW / 130 PS at 3800 RPM	18.2 : 1 ± 0.5 : 1	86 mm (3.385 in)	86 mm (3.385 in)
2.5 liter	2497 cm ³ (152 in ³)	60° “Vee” 6 Cylinder 24 Valves	244 Nm / 180 lb ft at 3000 RPM	194 BHP / 145 kW / 197 PS at 6800 RPM	241 Nm / 178 lb ft at 3000 RPM	192 BHP / 143.5 kW / 196 PS at 6800 RPM	10.30 : 1 ± 0.35 : 1	81.65 mm (3.214 in)	79.5 mm (3.130 in)
3.0 liter	2967 cm ³ (181 in ³)	60° “Vee” 6 Cylinder 24 Valves	284 Nm / 210 lb ft at 3000 RPM	231 BHP / 172 kW / 234 PS at 6800 RPM	279.3 Nm / 206 lb ft at 3000 RPM	227 BHP / 169.4 kW / 231 PS at 6800 RPM	10.5 : 1 ± 0.5 : 1	89.0 mm (3.504 in)	79.5 mm (3.130 in)

Notes

V8 – Cylinder Numbering and Firing Order

Notes

V8
up to 2002.5 MY

V8
2002.5 MY onwards

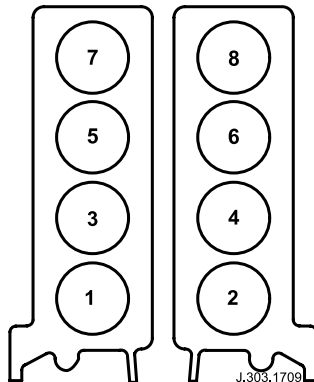
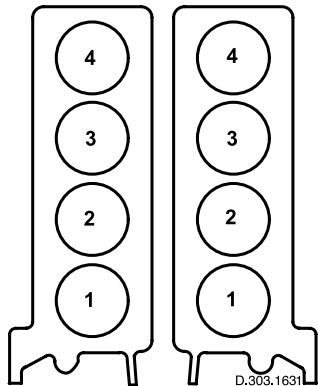

Front of Engine
Bank 1 Bank 2

Front of Engine
Bank 1 Bank 2

Firing Order:

Firing Order:

(Bank) – Cylinder

1 : 2 : 7 : 3 : 4 : 5 : 6 : 8

(1)-1 : (2)-1 : (1)-4 : (1)-2 : (2)-2 : (1)-3 : (2)-3 : (2)-4

V6 – Cylinder Numbering and Firing Order

Notes

V6
S-TYPE up to 2002.5 MY

V6
X-TYPE 2001.5 MY onwards
S-TYPE 2002.5 MY onwards
XJ 2003.5 MY onwards

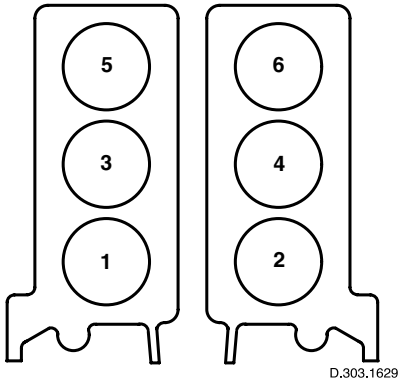
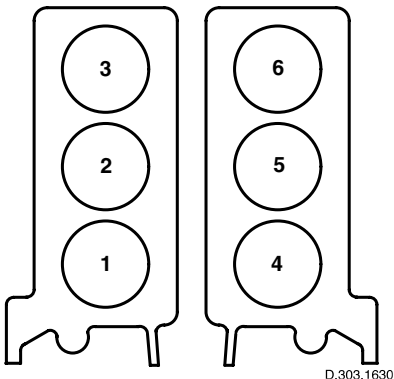

Bank 1 Front of Engine Bank 2
Firing Order:
1 : 4 : 2 : 5 : 3 : 6

Bank 1 Front of Engine Bank 2
Firing Order:
1 : 2 : 3 : 4 : 5 : 6

2.0 Liter Diesel – Cylinder Numbering and Firing Order

X-TYPE
2004.25 MY onwards

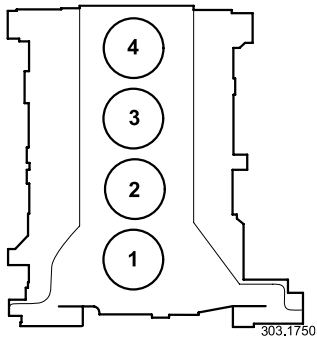

Front of Engine

Firing Order
1 – 3 – 4 – 2

Notes

Engine	Valve Clearances (cold)		<u>Notes</u>
	Intake	Exhaust	
V8	0.18 – 0.22 mm	0.23 – 0.27 mm	
V6	0.175 – 0.225 mm	0.325 – 0.375 mm	
2.0 Liter Diesel	No adjustment necessary		

Model/Engine	VIN		Market	Spark Plug Part Number	Spark Plug Gap mm (inches)	Engine Type
	From	To				
XJ: 1998 MY						
3.2 liter	812317	853935	ROW	NCA385OFA 1	1.2 – 1.3 (0.047 – 0.051)	AJ26 V8
4.0 liter			NAS	NCA385OHA 1	1.2 – 1.3 (0.047 – 0.051)	
			ROW	NCA385OFA 1		
4.0 liter – supercharged			All	NCA385OHA 2	1.2 – 1.3 (0.047 – 0.051)	
All			Leaded	NCA385OCA (service fit only)	1.0 – 1.1 (0.039 – 0.043)	
XJ: 1999 up to 2003.5 MY						
3.2 liter	853936	F59525	ROW	AJ8 4575 (iridium)	0.9 – 1.0 (0.035 – 0.039)	AJ27 V8
4.0 liter			All	AJ8 4575 (iridium)	0.9 – 1.0 (0.035 – 0.039)	
4.0 liter – supercharged			All	NCA385OHA 2 up to 2000 MY	1.2 – 1.3 (0.047 – 0.051)	AJ26.5 V8
				AJ8 4575 (iridium) from 2000 MY	0.9 – 1.0 (0.035 – 0.039)	AJ27 V8
All			Leaded	XR8 15350 (service fit only) *	1.0 – 1.1 (0.039 – 0.043)	–
XJ: 2003.5 MY onwards						
3.0 liter	G00442	Current	All	XR8 42795	1.32 – 1.42 (0.051 – 0.056)	V6
3.5 liter			All	AJ8 4575 (iridium)	0.9 – 1.0 (0.035 – 0.039)	AJ33 V8
4.2 liter			All	AJ8 4575 (iridium)	0.9 – 1.0 (0.035 – 0.039)	
4.2 liter – supercharged			All	AJ8 4575 (iridium)	0.9 – 1.0 (0.035 – 0.039)	

Note: * Not applicable with the introduction of “iridium” spark plugs.

Notes

Model/Engine	VIN		Market	Spark Plug Part Number	Spark Plug Gap mm (inches)	Engine Type
	From	To				
XK: 1997 up to 1998 MY						
4.0 liter	001246	018107	NAS	NCA385OHA 1	1.2 – 1.3 (0.047 – 0.051)	AJ26 V8
			ROW	NCA385ODA 2	1.0 – 1.1 (0.039 – 0.043)	
			Leaded	NCA385OCA (service fit only)		
XK: 1998 and 1999 MY						
4.0 liter	018108	A00115	NAS	NCA385OHA 1 up to 1999 MY	1.2 – 1.3 (0.047 – 0.051)	AJ26 V8
				AJ8 4575 (iridium) from 1999 MY	0.9 – 1.0 (0.035 – 0.039)	AJ27 V8
			ROW	NCA385OFA 1 up to 1999 MY	1.2 – 1.3 (0.047 – 0.051)	AJ26 V8
				AJ8 4575 (iridium) from 1999 MY	0.9 – 1.0 (0.035 – 0.039)	AJ27 V8
4.0 liter – supercharged	**		All	NCA385OHA 2	1.2 – 1.3 (0.047 – 0.051)	AJ26 V8 and AJ26.5 V8
All			Leaded	NCA385OCA (service fit only)	1.0 – 1.1 (0.039 – 0.043)	–
XK: 2000 up to 2003 MY						
4.0 liter	A00116	A30644	All	AJ8 4575 (iridium)	0.9 – 1.0 (0.035 – 0.039)	AJ27 V8
4.0 liter – supercharged			All	AJ8 4575 (iridium)	0.9 – 1.0 (0.035 – 0.039)	
All			Leaded	XR8 15350 (service fit only) *	1.0 – 1.1 (0.039 – 0.043)	–
XK: 2003 MY onwards						
4.2 liter	A30645	Current	All	AJ8 4575 (iridium)	0.9 – 1.0 (0.035 – 0.039)	AJ33 V8
4.2 liter – supercharged			All	AJ8 4575 (iridium)	0.9 – 1.0 (0.035 – 0.039)	

Note: * Not applicable with the introduction of “iridium” spark plugs.

Note: ** Supercharged engine introduced at VIN 024687.

Model/Engine	VIN		Market	Spark Plug Part Number	Spark Plug Gap mm (inches)	Engine Type
	From	To				
S-TYPE: 1999.25 up to 2002.5 MY						
3.0 liter	L00600	M45254	All	XR8 42795	1.32 – 1.42 (0.051 – 0.056)	V6
			Leaded	XR8 15349 (service fit only)	1.0 – 1.1 (0.039 – 0.043)	
4.0 liter			All	AJ8 4575 (iridium)	0.9 – 1.0 (0.035 – 0.039)	AJ28 V8
			Leaded	XR8 15350 (service fit only) *	1.0 – 1.1 (0.039 – 0.043)	
S-TYPE: 2002.5 MY onwards						
2.5 liter	M45255	Current	All	XR8 42795	1.32 – 1.42 (0.051 – 0.056)	V6
3.0 liter			All	XR8 42795	1.32 – 1.42 (0.051 – 0.056)	V6
4.2 liter			All	AJ8 4575 (iridium)	0.9 – 1.0 (0.035 – 0.039)	AJ33 V8
4.2 liter – supercharged			All	AJ8 4575 (iridium)	0.9 – 1.0 (0.035 – 0.039)	

Note: * Not applicable with the introduction of “iridium” spark plugs.

Notes

Model/Engine	VIN		Market	Spark Plug Part Number	Spark Plug Gap mm (inches)	Engine Type
	From	To				
X-TYPE: 2001.5 MY onwards						
2.0 liter	C00344	Current	All	XR8 42795	1.32 – 1.42 (0.051 – 0.056)	V6
2.5 liter			All	XR8 42795	1.32 – 1.42 (0.051 – 0.056)	V6
3.0 liter			All	XR8 42795	1.32 – 1.42 (0.051 – 0.056)	V6

Notes

Model/Engine	Market	Oil Specification	Engine Oil Capacity (service oil fill and filter change) Liters (US Quarts)		VIN	
			oil cooler	non oil cooler	From	To
XJ: 1998 up to 2000 MY						
3.2 liter	ROW	API SJ and ACEA A2	-	6.0 (6.4)	812317	878717
4.0 liter	NAS	API SJ and ILSAC GF-2 or API SL and ILSAC GF-3	-	6.0 (6.4)		
	ROW	API SJ and ACEA A2				
4.0 liter – supercharged	NAS	API SJ and ILSAC GF-2 or API SL and ILSAC GF-3	6.0 (6.4)	-		
	ROW	API SJ and ACEA A3				

Note: Refer to the end of this section for important information.

Notes

Model/Engine	Market	Oil Specification	Engine Oil Capacity (service oil fill and filter change) Liters (US Quarts)		VIN		
			oil cooler	non oil cooler	From	To	
XJ: 2000 MY							
3.2 liter	ROW	API SJ / EC and ACEA A1 or A3 Jaguar WSS-M2C913-B preferred	-	6.0 (6.4)	F00103	F00463	
				7.0 (7.4)	F00464	F20644	
4.0 liter	NAS	API SJ / EC and ILSAC GF-2 or API SL and ILSAC GF-3	-	6.0 (6.4)	F00103	F00463	
				7.0 (7.4)	F00464	F20644	
	ROW	API SJ / EC and ACEA A1 or A3 Jaguar WSS-M2C913-B preferred	-	6.0 (6.4)	F00103	F00463	
				7.0 (7.4)	F00464	F20644	
4.0 liter – supercharged	NAS	API SJ / EC and ILSAC GF-2 or API SL and ILSAC GF-3	6.0 (6.4)	-	F00103	F00463	
			7.0 (7.4)	-	F00464	F20644	
	ROW	API SJ / EC and ACEA A1 or A3 Jaguar WSS-M2C913-B preferred	-	6.0 (6.4)	-	F00103	F00463
				7.0 (7.4)	-	F00464	F20644

Note: Refer to the end of this section for important information.

Notes

Model/Engine	Market	Oil Specification	Engine Oil Capacity (service oil fill and filter change) Liters (US Quarts)		VIN	
			oil cooler	non oil cooler	From	To
XJ: 2001 MY						
3.2 liter	ROW	API SJ / EC and ACEA A1 or A3 Jaguar WSS-M2C913-B preferred	-	7.0 (7.4)	F20645	F41862
4.0 liter	NAS	API SJ / EC and ILSAC GF-2 or API SL and ILSAC GF-3	-	7.0 (7.4)		
	ROW	API SJ / EC and ACEA A1 or A3 Jaguar WSS-M2C913-B preferred				
4.0 liter – supercharged	NAS	API SJ / EC and ILSAC GF-2 or API SL and ILSAC GF-3	7.0 (7.4)	-		
	ROW	API SJ / EC and ACEA A1 or A3 Jaguar WSS-M2C913-B preferred				

Note: Refer to the end of this section for important information.

Notes

Model/Engine	Market	Oil Specification	Engine Oil Capacity (service oil fill and filter change) Liters (US Quarts)		VIN	
			oil cooler	non oil cooler	From	To
XJ: 2002 up to 2003.5 MY						
3.2 liter	ROW	API S/ EC and ACEA A1 or A3 Jaguar WSS-M2C913-B preferred	-	7.0 (7.4)	F41863	F59525
4.0 liter	NAS	API SL and ILSAC GF-3	-	7.0 (7.4)		
	ROW	API S/ EC and ACEA A1 or A3 Jaguar WSS-M2C913-B preferred				
4.0 liter – supercharged	NAS	API SL and ILSAC GF-3	7.0 (7.4)	-		
	ROW	API S/ EC and ACEA A1 or A3 Jaguar WSS-M2C913-B preferred				

Note: Refer to the end of this section for important information.

Notes

Model/Engine	Market	Oil Specification	Engine Oil Capacity (service oil fill and filter change) Liters (US Quarts)		VIN	
			oil cooler	non oil cooler	From	To
XJ: 2003.5 MY onwards						
3.0 liter	NAS	API SL and ILSAC GF-3	6.5 (6.9)	-	G00442	Current
	ROW	API SJ / EC and ACEA A1 or A3 Jaguar WSS-M2C913-B preferred				
3.5 liter	NAS	API SL and ILSAC GF-3	6.0 (6.4)	-		
	ROW	API SJ / EC and ACEA A1 or A3 Jaguar WSS-M2C913-B preferred				
4.2 liter	NAS	API SL and ILSAC GF-3	6.0 (6.4)	-		
	ROW	API SJ / EC and ACEA A1 or A3 Jaguar WSS-M2C913-B preferred				
4.2 liter – supercharged	NAS	API SL and ILSAC GF-3	6.0 (6.4)	-		
	ROW	API SJ / EC and ACEA A1 or A3 Jaguar WSS-M2C913-B preferred				

Note: Refer to the end of this section for important information.

Notes

Model/Engine	Market	Oil Specification	Engine Oil Capacity (service oil fill and filter change) Liters (US Quarts)		VIN	
			oil cooler	non oil cooler	From	To
XK: 1997 MY						
4.0 liter	NAS	API SJ and ILSAC GF-2 or API SL and ILSAC GF-3	6.0 (6.4)	-	001246	018107
	ROW	API SJ and ACEA A2				
XK: 1998 MY						
4.0 liter	NAS	API SJ and ILSAC GF-2 or API SL and ILSAC GF-3	-	6.0 (6.4)	018108	024686
	ROW	API SJ and ACEA A2				
XK: 1998.75 MY						
4.0 liter	NAS	API SJ and ILSAC GF-2 or API SL and ILSAC GF-3	-	6.0 (6.4)	024687	031302
	ROW	API SJ and ACEA A2				
4.0 liter – supercharged	ROW	API SJ and ACEA A3	6.0 (6.4)	-		

Note: Refer to the end of this section for important information.

Notes

Model/Engine	Market	Oil Specification	Engine Oil Capacity (service oil fill and filter change) Liters (US Quarts)		VIN	
			oil cooler	non oil cooler	From	To
XK: 1999 MY						
4.0 liter	NAS	API S/ EC and ILSAC GF-2 or API SL and ILSAC GF-3	-	6.0 (6.4)	031303	042775
	ROW	API S/ EC and ACEA A1 or A3 Jaguar WSS-M2C913-B preferred				
4.0 liter – supercharged	NAS	API S/ EC and ILSAC GF-2 or API SL and ILSAC GF-3	6.0 (6.4)	-		
	ROW	API S/ EC and ACEA A1 or A3 Jaguar WSS-M2C913-B preferred				

Note: Refer to the end of this section for important information.

Notes

Model/Engine	Market	Oil Specification	Engine Oil Capacity (service oil fill and filter change) Liters (US Quarts)		VIN	
			oil cooler	non oil cooler	From	To
XK: 2000 MY						
4.0 liter	NAS	API SJ / EC and ILSAC GF-2 or API SL and ILSAC GF-3	-	6.0 (6.4)	A00116	A00366
				7.0 (7.4)	A00367	A11139
	ROW	API SJ / EC and ACEA A1 or A3 Jaguar WSS-M2C913-B preferred	-	6.0 (6.4)	A00116	A00366
				7.0 (7.4)	A00367	A11139
4.0 liter – supercharged	NAS	API SJ / EC and ILSAC GF-2 or API SL and ILSAC GF-3	6.0 (6.4)	-	A00116	A00366
			7.0 (7.4)	-	A00367	A11139
	ROW	API SJ / EC and ACEA A1 or A3 Jaguar WSS-M2C913-B preferred	6.0 (6.4)	-	A00116	A00366
			7.0 (7.4)	-	A00367	A11139
XK: 2001 MY						
4.0 liter	NAS	API SL and ILSAC GF-3	-	7.0 (7.4)	A11140	A24195
	ROW	API SJ / EC and ACEA A1 or A3 Jaguar WSS-M2C913-B preferred				
4.0 liter – supercharged	NAS	API SL and ILSAC GF-3	7.0 (7.4)	-		
	ROW	API SJ / EC and ACEA A1 or A3 Jaguar WSS-M2C913-B preferred				

Note: Refer to the end of this section for important information.

Notes

Model/Engine	Market	Oil Specification	Engine Oil Capacity (service oil fill and filter change) Liters (US Quarts)		VIN	
			oil cooler	non oil cooler	From	To
XK: 2002 up to 2003 MY						
4.0 liter	NAS	API SL and ILSAC GF-3	7.0 (7.4)	-	A24196	A30644
	ROW	API S/ EC and ACEA A1 or A3 Jaguar WSS-M2C913-B preferred				
4.0 liter – supercharged	NAS	API SL and ILSAC GF-3	7.0 (7.4)	-		
	ROW	API S/ EC and ACEA A1 or A3 Jaguar WSS-M2C913-B preferred				
XK: 2003 MY onwards						
4.2 liter	NAS	API SL and ILSAC GF-3	7.0 (7.4)	-	A30645	Current
	ROW	API S/ EC and ACEA A1 or A3 Jaguar WSS-M2C913-B preferred				
4.2 liter – supercharged	NAS	API SL and ILSAC GF-3	7.0 (7.4)	-		
	ROW	API S/ EC and ACEA A1 or A3 Jaguar WSS-M2C913-B preferred				

Note: Refer to the end of this section for important information.

Notes

Model/Engine	Market	Oil Specification	Engine Oil Capacity (service oil fill and filter change) Liters (US Quarts)		VIN	
			oil cooler	non oil cooler	From	To
S-TYPE: 1999.25 MY						
3.0 liter	NAS	API SJ / EC and ILSAC GF-2 or API SL and ILSAC GF-3	5.7 (6.0)	-	L00600	L31320
	ROW	API SJ / EC and ACEA A1 or A3 Jaguar WSS-M2C913-B preferred				
4.0 liter	NAS	API SJ / EC and ILSAC GF-2 or API SL and ILSAC GF-3	6.0 (6.4)	-		
	ROW	API SJ / EC and ACEA A1 or A3 Jaguar WSS-M2C913-B preferred				

Note: Refer to the end of this section for important information.

Notes

Model/Engine	Market	Oil Specification	Engine Oil Capacity (service oil fill and filter change) Liters (US Quarts)		VIN	
			oil cooler	non oil cooler	From	To
S-TYPE: 2000 up to 2002.5 MY						
3.0 liter	NAS	API SL and ILSAC GF-3	5.7 (6.0)	–	L31321	L37177
			6.5 (6.9)	–	L37178*	M45254
	ROW	API S/ EC and ACEA A1 or A3 Jaguar WSS-M2C913-B preferred	5.7 (6.0)	–	L31321	L37177
			6.5 (6.9)	–	L37178*	M45254
4.0 liter	NAS	API SL and ILSAC GF-3	6.0 (6.4)	–	L31321	M45254
	ROW	API S/ EC and ACEA A1 or A3 Jaguar WSS-M2C913-B preferred				

Note: To signify the oil capacity change to S-TYPE V6 engines during 2000 MY, a new style oil-level gauge was introduced. The new style gauge can be recognized by a loop handle opposed to the old T-bar design. The oil fill mark on the oil-level gauge was also altered by 14 mm. The change was implemented at approximate VIN*.

Note: Refer to the end of this section for important information.

Notes

Model/Engine	Market	Oil Specification	Engine Oil Capacity (service oil fill and filter change) Liters (US Quarts)		VIN	
			oil cooler	non oil cooler	From	To
S-TYPE: 2002.5 MY onwards						
2.5 liter	NAS	API SL and ILSAC GF-3	6.5 (6.9)	-	M45255	Current
	ROW	API S/ EC and ACEA A1 or A3 Jaguar WSS-M2C913-B preferred				
3.0 liter	NAS	API SL and ILSAC GF-3	6.5 (6.9)	6.5 (6.9)		
	ROW	API S/ EC and ACEA A1 or A3 Jaguar WSS-M2C913-B preferred	6.5 (6.9)	-		
4.2 liter	NAS	API SL and ILSAC GF-3	6.0 (6.4)	-		
	ROW	API S/ EC and ACEA A1 or A3 Jaguar WSS-M2C913-B preferred				
4.2 liter – supercharged	NAS	API SL and ILSAC GF-3	6.0 (6.4)	-		
	ROW	API S/ EC and ACEA A1 or A3 Jaguar WSS-M2C913-B preferred				

Note: Refer to the end of this section for important information.

Notes

Model/Engine	Market	Oil Specification	Engine Oil Capacity (service oil fill and filter change) Liters (US Quarts)		VIN	
			oil cooler	non oil cooler	From	To
X-TYPE: 2001.5 MY onwards						
2.0 liter Gasoline	NAS	API SL and ILSAC GF-3	5.8 (6.1)	-	C00344	Current
	ROW	API SJ / EC and ACEA A1 or A3 Jaguar WSS-M2C913-B preferred				
2.0 liter Diesel	EUR	Jaguar WSS-M2C913-B only	6.2 (6.5)	-		
2.5 liter	NAS	API SL and ILSAC GF-3	5.8 (6.1)	-		
	ROW	API SJ / EC and ACEA A1 or A3 Jaguar WSS-M2C913-B preferred				
3.0 liter	NAS	API SL and ILSAC GF-3	5.8 (6.1)	-		
	ROW	API SJ / EC and ACEA A1 or A3 Jaguar WSS-M2C913-B preferred				

Caution: The use of supplementary oil or fuel additives is not approved unless specified by Jaguar Cars in the form of a service communication or directive.

V6 gasoline engine oil specification (NAS): Synthetic oil meeting the following specification may be used API SL and ILSAC GF-3.

V6 gasoline engine oil specification (ROW): Synthetic oil meeting the following specification may be used API SJ / EC and ACEA A1 or A3.

SAE Viscosity Rating: For climates ranging from -30°C (-22°F) and +50°C (+122°F), the following oil viscosities may be used:

0W-30 5W-30 (preferred)

0W-40 5W-40

Model/Engine	VIN		Market	Final Drive Ratio	<u>Notes</u>
	From	To			
XJ: 1998 up to 2003.5 MY					
3.2 liter	812317	F59525	ROW	3.27 : 1	
4.0 liter			NAS	3.06 : 1	
			ROW		
			Mexico	3.27 : 1	
4.0 liter – supercharged			NAS	3.06 : 1	
			ROW		
XJ: 2003.5 MY onwards					
3.0 liter	G00442	Current	NAS	3.31 : 1	
			ROW		
3.5 liter			NAS	3.07 : 1	
			ROW		
4.0 liter			NAS	2.87 : 1	
			ROW		
4.0 liter – supercharged			NAS	2.87 : 1	
			ROW		

Model/Engine	VIN		Market	Final Drive Ratio	<u>Notes</u>
	From	To			
XK: 1997 up to 2003 MY					
4.0 liter	001246	A30644	NAS	3.06 : 1	
			ROW		
			Mexico	3.27 : 1	
4.0 liter – supercharged			NAS	3.06 : 1	
			ROW		
XK: 2003 MY onwards					
4.2 liter	A30645	Current	NAS	3.06 : 1	
			ROW		
4.2 liter – supercharged			NAS	3.06 : 1	
			ROW		

Model/Engine	VIN		Market	Final Drive Ratio	<u>Notes</u>
	From	To			
S-TYPE: 1999.25 MY					
3.0 liter – manual	L00600	L31320	NAS	3.07 : 1	
			ROW		
3.0 liter – automatic			NAS	3.31 : 1	
			ROW		
4.0 liter – automatic			NAS	3.31 : 1	
			ROW		
S-TYPE: 2000 up to 2002.5 MY					
3.0 liter – manual	L31321	M45254	NAS	3.07 : 1	
			ROW		
3.0 liter – automatic			NAS	3.31 : 1	
			ROW		
			Mexico	3.58 : 1	
4.0 liter – automatic			NAS	3.31 : 1	
			ROW		

Model/Engine	VIN		Market	Final Drive Ratio	<u>Notes</u>
	From	To			
S-TYPE: 2002.5 MY onwards					
2.5 liter – manual	M45255	Current	NAS	3.07 : 1	
			ROW		
2.5 liter – automatic			NAS	3.31 : 1	
			ROW		
3.0 liter – manual			NAS	3.07 : 1	
			ROW		
3.0 liter – automatic			NAS	3.31 : 1	
			ROW		
4.2 liter – automatic			NAS	2.87 : 1	
			ROW		
4.2 liter – automatic supercharged			NAS	2.87 : 1	
			ROW		
X-TYPE: 2001.5 MY onwards					
2.5 liter	C00344	Current	NAS	2.53 : 1	
			ROW		
3.0 liter			NAS	2.53 : 1	
			ROW		

Model/Engine	VIN		Transmission			Differential		
	From	To	Lubricant	Part No	Capacity Liters (US Quarts)	Lubricant	Part No	Capacity Liters (US Quarts)
Xj: 1998 MY up to 2003.5 MY								
3.2 liter Auto	812317	F59525	Esso LT 71141	JLM 20237	10.0 (10.6)	Shell Spirax Super TS90	JLM 20255	1.9 (2.0)
4.0 liter Auto			Esso LT 71141	JLM 20237	10.0 (10.6)	Shell Spirax Super TS90	JLM 20255	1.9 (2.0)
4.0 liter SC Auto			Shell ATF 3403 M115	JLM 20292	9.5 (10.0)	Shell Spirax Super TS90	JLM 20255	1.9 (2.0)
Xj: 2003.5 MY onwards								
3.0 liter Auto	G00442	Current	Shell M1375.4	C2C 8432	9.5 (10.0)	M2C 192A Synthetic	JLM 20771	1.25 (1.32)
3.5 liter Auto			Shell M1375.4	C2C 8432	9.5 (10.0)	M2C 192A Synthetic	JLM 20771	1.25 (1.32)
4.2 liter Auto			Shell M1375.4	C2C 8432	9.5 (10.0)	M2C 192A Synthetic	JLM 20771	1.25 (1.32)
4.2 liter SC Auto			Shell M1375.4	C2C 8432	10.05 (10.6)	M2C 192A Synthetic	JLM 20771	1.25 (1.32)

Note: Capacity figures quoted are maximum fill.

Notes

Model/Engine	VIN		Transmission			Differential		
	From	To	Lubricant	Part No	Capacity Liters (US Quarts)	Lubricant	Part No	Capacity Liters (US Quarts)
XK: 1997 up to 1998.75 MY								
4.0 liter Auto	001246	024686	Esso LT 71141	JLM 20237	10.0 (10.6)	Shell Spirax Super TS90	JLM 20255	1.9 (2.0)
XK: 1998.75 up to 2003 MY								
4.0 liter Auto	024687	A30644	Esso LT 71141	JLM 20237	10.0 (10.6)	Shell Spirax Super TS90	JLM 20255	1.9 (2.0)
4.0 liter SC Auto			Shell ATF 3403 M115	JLM 20292	9.5 (10.0)	Shell Spirax Super TS90	JLM 20255	1.9 (2.0)
XK: 2003 MY onwards								
4.2 liter Auto	A30645	Current	Shell M1375.4	C2C 8432	9.5 (10.0)	Shell Spirax Super TS90	JLM 20255	1.9 (2.0)
4.2 liter SC Auto			Shell M1375.4	C2C 8432	10.05 (10.6)	Shell Spirax Super TS90	JLM 20255	1.9 (2.0)

Note: Capacity figures quoted are maximum fill.

Notes

Model/Engine	VIN		Transmission			Differential		
	From	To	Lubricant	Part No	Capacity Liters (US Quarts)	Lubricant	Part No	Capacity Liters (US Quarts)
S-TYPE: 1999.25 up to 2002.5 MY								
3.0 liter Man	L00600	M45254	Esso D21065	JLM 20937	1.1 (1.2)	M2C 192A Synthetic	JLM 20771	1.5 (1.6)
3.0 liter Auto			MERCON™ V XT-5-QM	JLM 21044	9.0 (9.5)	M2C 192A Synthetic	JLM 20771	1.5 (1.6)
4.0 liter Auto			MERCON™ V XT-5-QM	JLM 21044	9.0 (9.5)	M2C 192A Synthetic	JLM 20771	1.5 (1.6)
S-TYPE: 2002.5 MY onwards								
2.5 liter Man	M45255	Current	Esso LT 71141	JLM 20237	1.1 (1.2)	M2C 192A Synthetic	JLM 20771	1.25 (1.32)
2.5 liter Auto			Shell M1375.4	C2C 8432	9.5 (10.0)	M2C 192A Synthetic	JLM 20771	1.25 (1.32)
3.0 liter Man			Esso LT 71141	JLM 20237	1.1 (1.2)	M2C 192A Synthetic	JLM 20771	1.25 (1.32)
3.0 liter Auto			Shell M1375.4	C2C 8432	9.5 (10.0)	M2C 192A Synthetic	JLM 20771	1.25 (1.32)
4.2 liter Auto			Shell M1375.4	C2C 8432	9.5 (10.0)	M2C 192A Synthetic	JLM 20771	1.25 (1.32)
4.2 liter SC Auto			Shell M1375.4	C2C 8432	10.05 (10.6)	M2C 192A Synthetic	JLM 20771	1.25 (1.32)

Note: Capacity figures quoted are maximum fill.

Notes

Model/Engine	VIN		Transmission			Differential		
	From	To	Lubricant	Part No	Capacity Liters (US Quarts)	Lubricant	Part No	Capacity Liters (US Quarts)
X-TYPE: 2001.5 MY onwards								
2.0 liter Gasoline Man	C00344	Current	Castrol BOT 130M	C2S 19889	1.9 (2.0)	–	–	–
2.0 liter Gasoline Auto			ATF IDEMITSU K17 (Jatco 3100 PL085)	C2S 12120	8.8 (9.3)	–	–	–
2.0 liter Diesel Man			Castrol BOT 130M	C2S 19889	1.9 (2.0)	–	–	–
2.5 liter Man			Castrol BOT 130M	C2S 19889	1.75 (1.8)	M2C 192A Synthetic	JLM 20771	1.15 (1.2)
2.5 liter Auto			ATF IDEMITSU K17 (Jatco 3100 PL085)	C2S 12120	8.8 (9.3)	M2C 192A Synthetic	JLM 20771	1.15 (1.2)
3.0 liter Man			Castrol BOT 130M	C2S 19889	1.75 (1.8)	M2C 192A Synthetic	JLM 20771	1.15 (1.2)
3.0 liter Auto			ATF IDEMITSU K17 (Jatco 3100 PL085)	C2S 12120	8.8 (9.3)	M2C 192A Synthetic	JLM 20771	1.15 (1.2)
Transfer Case								
2.5 and 3.0 liter			M2C 192A Synthetic	JLM 20771	0.6 (0.6)			

Note: Capacity figures quoted are maximum fill.

Notes

Model/Engine	VIN		Market	Coolant Specification	Part Number	Coolant Capacities 50% water + 50% coolant Liters (US Quarts)	Notes
	From	To					
XJ: 1998 MY							
3.2 liter	812317	853935	All	DOW D542	JLM 20404/*	10.0 (10.6)	
4.0 liter			All	DOW D542	JLM 20404/*	10.0 (10.6)	
4.0 liter – supercharged			All	DOW D542	JLM 20404/*	12.0 (12.7)	
XJ: 1999 MY							
3.2 liter	853936	878388	All	DOW D542	JLM 20404/*	10.0 (10.6)	
	878389	878717	All	WSS M97B44–D	JLM 20972/*		
4.0 liter	853936	878388	All	DOW D542	JLM 20404/*	10.0 (10.6)	
	878389	878717	All	WSS M97B44–D	JLM 20972/*		
4.0 liter – supercharged	853936	878388	All	DOW D542	JLM 20404/*	12.0 (12.7)	
	878389	878717	All	WSS M97B44–D	JLM 20972/*		
XJ: 2000 up to 2003.5 MY							
3.2 liter	F00103	F59525	All	WSS M97B44–D	JLM 20972/*	10.0 (10.6)	
4.0 liter			All	WSS M97B44–D	JLM 20972/*	10.0 (10.6)	
4.0 liter – supercharged			All	WSS M97B44–D	JLM 20972/*	12.0 (12.7)	

Note: * denotes container quantity when substituted with a number.

Caution: Coolant JLM 20972 is of the organic acid technology (OAT) type and must not be mixed with other types of coolant.

Model/Engine	VIN		Market	Coolant Specification	Part Number	Coolant Capacities 50% water + 50% coolant Liters (US Quarts)	<u>Notes</u>
	From	To					
XJ: 2003.5 MY onwards							
3.0 liter – 2 Zone	G00442	Current	All	WSS M97B44–D	JLM 20972/*	10.25 (10.83) approx.	
3.0 liter – 4 Zone			All	WSS M97B44–D	JLM 20972/*	11.05 (11.67) approx.	
3.5 liter – 2 Zone			All	WSS M97B44–D	JLM 20972/*	9.45 (9.98) approx.	
3.5 liter – 4 Zone			All	WSS M97B44–D	JLM 20972/*	10.25 (10.83) approx.	
4.2 liter – 2 Zone			All	WSS M97B44–D	JLM 20972/*	9.45 (9.98) approx.	
4.2 liter – 4 Zone			All	WSS M97B44–D	JLM 20972/*	10.25 (10.83) approx.	
4.2 liter – SC – 2 Zone			All	WSS M97B44–D	JLM 20972/*	12.35 (13.05) approx.	
4.2 liter – SC – 4 Zone			All	WSS M97B44–D	JLM 20972/*	13.15 (13.89) approx.	

Note: * denotes container quantity when substituted with a number.

Caution: Coolant JLM 20972 is of the organic acid technology (OAT) type and must not be mixed with other types of coolant.

Model/Engine	VIN		Market	Coolant Specification	Part Number	Coolant Capacities 50% water + 50% coolant Liters (US Quarts)	Notes
	From	To					
XK: 1997 up to 1998.75 MY							
4.0 liter	001246	024686	All	DOW D542	JLM 20404/*	9.5 (10.0)	
XK: 1998.75 up to 2000 MY							
4.0 liter	024687	042634	All	DOW D542	JLM 20404/*	9.5 (10.0)	
	042635	042775	All	WSS M97B44-D	JLM 20972/*		
4.0 liter – supercharged	024687	042634	All	DOW D542	JLM 20404/*	11.5 (12.1)	
	042635	042775	All	WSS M97B44-D	JLM 20972/*		
XK: 2000 up to 2003 MY							
4.0 liter	A00116	A30644	All	WSS M97B44-D	JLM 20972/*	9.5 (10.0)	
4.0 liter – supercharged			All	WSS M97B44-D	JLM 20972/*	11.5 (12.1)	
XK: 2003 MY onwards							
4.2 liter	A30645	Current	All	WSS M97B44-D	JLM 20972/*	9.5 (10.0)	
4.2 liter – supercharged			All	WSS M97B44-D	JLM 20972/*	11.5 (12.1)	

Note: * denotes container quantity when substituted with a number.

Caution: Coolant JLM 20972 is of the organic acid technology (OAT) type and must not be mixed with other types of coolant.

Model/Engine	VIN		Market	Coolant Specification	Part Number	Coolant Capacities 50% water + 50% coolant Liters (US Quarts)	<u>Notes</u>
	From	To					
S-TYPE: 1999.25 up to 2002.5 MY							
3.0 liter	L00600	M45254	All	WSS M97B44-D	JLM 20972/*	10.4 (11.0)	
4.0 liter			All	WSS M97B44-D	JLM 20972/*	10.0 (10.6)	
S-TYPE: 2002.5 MY onwards							
2.5 liter	M45255	Current	All	WSS M97B44-D	JLM 20972/*	9.4 (9.9)	
3.0 liter			All	WSS M97B44-D	JLM 20972/*	9.4 (9.9)	
4.2 liter			All	WSS M97B44-D	JLM 20972/*	10.1 (10.7)	
4.2 liter – supercharged			All	WSS M97B44-D	JLM 20972/*	13.3 (14.0)	
X-TYPE: 2001.5 MY onwards							
2.0 liter Gasoline	C00344	Current	All	WSS M97B44-D	JLM 20972/*	10.0 (10.6)	
2.0 liter Diesel			EUR	WSS M97B44-D	JLM 20972/*	10.1 (10.7)	
2.5 liter			All	WSS M97B44-D	JLM 20972/*	10.0 (10.6)	
3.0 liter			All	WSS M97B44-D	JLM 20972/*	10.0 (10.6)	

Note: * denotes container quantity when substituted with a number.

Caution: Coolant JLM 20972 is of the organic acid technology (OAT) type and must not be mixed with other types of coolant.

Model	VIN		Market	Refrigerant	Refrigerant Charge Weight	Compressor Lubricant	Compressor Lubricant Part Number	Compressor Lubricant Capacity
	From	To						
XJ: 1998 up to 2003.5 MY								
	812317	F59525	All	R134a	675g ± 25g	Polyalkyleneglycol	JLM 12260	160 – 200 ml
XJ: 2003.5 MY onwards								
2 Zone	G00442	Current	All	R134a	650g ± 25g	Polyalkyleneglycol	JLM 12260	140 ml
4 Zone			All	R134a	800g ± 25g	Polyalkyleneglycol	JLM 12260	180 ml
XK: 1997 MY onwards								
	001246	Current	All	R134a	650g ± 50g	Polyalkyleneglycol	JLM 12260	160 – 200 ml
S-TYPE: 1999.25 up to 2002.5 MY								
	L00600	M45254	All	R134a	800g ± 25g	Polyalkyleneglycol	XR8 3680	210 ml
S-TYPE: 2002.5 MY onwards								
	M45255	Current	All	R134a	750g ± 25g	Polyalkyleneglycol	XR8 3680	210 ml
X-TYPE: 2001.5 MY onwards								
Gasoline	C00344	Current	All	R134a	810g ± 15g	Polyalkyleneglycol	XR8 3680	220 ml
Diesel			EUR	R134a	735g ± 25g	Polyalkyleneglycol	XR8 3680	200 ml

Notes

Model/Engine	VIN		Market	Fluid Specification	Part Number	Oil Capacity Liters – US Quarts	<u>Notes</u>
	From	To					
XJ: 1998 MY up to 2003.5 MY							
3.2 liter	812317	F59525	All	Mobil ATF to Dexron 3 Specification	JLM 21703	1 approx.	
4.0 liter			All	Mobil ATF to Dexron 3 Specification	JLM 21703	1 approx.	
4.0 liter – supercharged			All	Mobil ATF to Dexron 3 Specification	JLM 21703	1 approx.	
XJ: 2003.5 MY onwards							
3.0 liter	G00442	Current	All	Mobil ATF to Dexron 3 Specification	JLM 21703	1.6 approx.	
3.5 liter			All	Mobil ATF to Dexron 3 Specification	JLM 21703	1.6 approx.	
4.2 liter			All	Mobil ATF to Dexron 3 Specification	JLM 21703	1.6 approx.	
4.2 liter – supercharged			All	Mobil ATF to Dexron 3 Specification	JLM 21703	1.6 approx.	

Model/Engine	VIN		Market	Fluid Specification	Part Number	Oil Capacity Liters – US Quarts	<u>Notes</u>
	From	To					
XK: 1997 up to 1998.75 MY							
4.0 liter	001246	024686	All	Mobil ATF to Dexron 3 Specification	JLM 21703	1 approx.	
XK: 1998.75 up to 2003 MY							
4.0 liter	024687	A30644	All	Mobil ATF to Dexron 3 Specification	JLM 21703	1 approx.	
4.0 liter – supercharged			All	Mobil ATF to Dexron 3 Specification	JLM 21703	1 approx.	
XK: 2003 MY onwards							
4.2 liter	A30645	Current	All	Mobil ATF to Dexron 3 Specification	JLM 21703	1 approx.	
4.2 liter – supercharged			All	Mobil ATF to Dexron 3 Specification	JLM 21703	1 approx.	

Model/Engine	VIN		Market	Fluid Specification	Part Number	Oil Capacity Liters – US Quarts	<u>Notes</u>
	From	To					
S-TYPE: 1999.25 up to 2001 MY							
3.0 liter – Manual	L00600	L86901	All	WSA–M2C195–A	JLM 20772	1 approx.	
3.0 liter – Automatic			All	WSA–M2C195–A	JLM 20772	1 approx.	
4.0 liter – Automatic			All	WSA–M2C195–A	JLM 20772	1 approx.	
S-TYPE: 2001 up to 2002.5 MY							
3.0 liter – Manual	L86902	M45254	All	Mobil ATF to Dexron 3 Specification	JLM 21703	1.6 approx.	
3.0 liter – Automatic			All	Mobil ATF to Dexron 3 Specification	JLM 21703	1.6 approx.	
4.0 liter – Automatic			All	Mobil ATF to Dexron 3 Specification	JLM 21703	1.6 approx.	
S-TYPE: 2002.5 MY onwards							
2.5 liter – Manual	M45255	Current	All	Mobil ATF to Dexron 3 Specification	JLM 21703	1.6 approx.	
2.5 liter – Automatic			All	Mobil ATF to Dexron 3 Specification	JLM 21703	1.6 approx.	
3.0 liter – Manual			All	Mobil ATF to Dexron 3 Specification	JLM 21703	1.6 approx.	
3.0 liter – Automatic			All	Mobil ATF to Dexron 3 Specification	JLM 21703	1.6 approx.	
4.2 liter – Automatic			All	Mobil ATF to Dexron 3 Specification	JLM 21703	1.6 approx.	
4.2 liter – Automatic supercharged			All	Mobil ATF to Dexron 3 Specification	JLM 21703	1.6 approx.	

Model/Engine	VIN		Market	Fluid Specification	Part Number	Oil Capacity Liters – US Quarts	<u>Notes</u>
	From	To					
X-TYPE: 2001.5 MY							
2.0 liter – Manual	C00344	Current	All	Mobil ATF to Dexron 3 Specification	JLM 21703	1.2 approx.	
2.0 liter – Automatic			All	Mobil ATF to Dexron 3 Specification	JLM 21703	1.2 approx.	
2.0 liter – Manual (Diesel)			EUR	Mobil ATF to Dexron 3 Specification	JLM 21703	1.5 approx.	
2.5 liter – Manual			All	Mobil ATF to Dexron 3 Specification	JLM 21703	1.2 approx.	
2.5 liter – Automatic			All	Mobil ATF to Dexron 3 Specification	JLM 21703	1.2 approx.	
3.0 liter – Manual			All	Mobil ATF to Dexron 3 Specification	JLM 21703	1.2 approx.	
3.0 liter – Automatic			All	Mobil ATF to Dexron 3 Specification	JLM 21703	1.2 approx.	

VIN		Wheel	Tire	Tire Unique Identifier	Vehicle / Chassis Specification
From	To				
XJ: 1998 up to 2003.5 MY					
812317	F59525	7" x 16"	225/60ZR 16 98W Pirelli P4000e	size/designation/ UK manufacture	Touring and Sport
			225/60ZR 16 98W Pirelli P6000	size/designation/ UK manufacture	
			225/55R 16 95W Continental EcoContact CP	Star marked	
			225/60R 16 Michelin Energy MXV4 Plus *	size/designation	Touring USA/Canada only
		8" x 16"	225/55ZR 16 95W J Pirelli P6000	J marked	Sport
		7.5" and 8" x 17"	235/50ZR 17 96Y Pirelli P6000	size/designation/ UK manufacture	Touring, Touring + CATS Sport, Supersport + CATS
		8" and 8.5" x 18"	255/40ZR 18 95Y Pirelli P-Zero asimmetrico	size/designation/ UK manufacture	Sport, Supersport + CATS
		8.5" x 19"	255/35ZR 19 Pirelli P-Zero	size/designation	Sport, Supersport + CATS
3.5" and 4" x 18"	T115/85R 18 96M Pirelli (temporary spare wheel)	size/designation	All		

Note: * Only fitted to USA and Canadian cars, limited to 195 km/h (121 mile/h).

Note: As tire fitment can vary in individual markets, consult the vehicle handbook or tire label for further information.

Notes

VIN		Wheel	Tire	Tire Unique Identifier	Vehicle / Chassis Specification
From	To				
XJ: 2003.5 MY onwards					
G00442	Current	7" x 17"	235/55HR 17 99H Pirelli P6 Four Seasons*	size/designation	V6 and V8 (not Sport or SC)
			235/55ZR 17 99W Pirelli P6000 Powergy	size/designation	
		8" x 18"	235/50HR 18 97H MichelinPilot HX MXM4*	size/designation	V6 and V8 (including Sport and super V8 SC)
			235/50HR 18 97H Continental ContiTouringContact*) marked	
			235/50ZR 18 97W Pirelli P6000 Powergy	size/designation	
		8.5" x 19"	255/40ZR 19 96Y Pirelli P-Zero	size/designation	XJR SC (also option on this range)
		9" x 20"	255/35ZR 20 97Y MichelinPilot Sport	size/designation	Option on this range
		4" x 18"	T135/80R 18 104M Pirelli (temporary spare wheel)	size/designation	All

Note: * Only fitted to USA and Canadian cars, limited to 195 km/h (121 mile/h).

Note: As tire fitment can vary in individual markets, consult the vehicle handbook or tire label for further information.

Notes

VIN		Wheel	Tire	Tire Unique Identifier	Vehicle / Chassis Specification
From	To				
XK: 1997 MY onwards					
001246	Current	8" x 17"	245/50ZR 17 99Y Pirelli P-Zero asimmetrico	size/designation/ UK manufacture	Sport
		8" and 8.5" x 18"	245/45ZR 18 96W Continental ContiSportContact	size/designation/) marked	Sport, Supersport + CATS
			245/45ZR 18 96Y Pirelli P-Zero direzionale	size/designation/ German manufacture	
		9" x 18"	255/45ZR 18 99W Continental ContiSportContact	size/designation/) marked	Sport, Supersport + CATS
			255/45ZR 18 99Y Pirelli P-Zero asimmetrico	size/designation/ German manufacture	
		8" x 19"	245/40R 19 98Y Pirelli P-Zero Rosso	size/designation	All
		9" x 19"	255/40R 19 100Y Pirelli P-Zero Rosso	size/designation	All
		9" x 20"	255/35ZR 20 97Y J Pirelli P-Zero direzionale	size/designation/) marked	Sport, Supersport + CATS
10" x 20"	285/30ZR 20 99Y J Pirelli P-Zero asimmetrico	size/designation/) marked	Sport, Supersport + CATS		
3.5" and 4" x 18"	T135/80R 18 104M Pirelli (temporary spare wheel)	size/designation	All		

Note: As tire fitment can vary in individual markets, consult the vehicle handbook or tire label for further information.

Notes

VIN		Wheel	Tire	Tire Unique Identifier	Vehicle / Chassis Specification
From	To				
S-TYPE: 1999.25 up to 2002.5 MY					
L00600	M45254	7" and 7.5" x 16"	225/55ZR 16 95W Pirelli P6000	J marked	Standard, OSNA markets
			225/55R 16 95W Continental EcoContact CP	Star marked	
			225/55R 16 95H Bridgestone Turanza EL42 *	size/designation	Standard, US markets only
		7.5" x 17"	235/50ZR 17 96W Pirelli P-Zero	size/designation	Standard and Sport
			245/45R 17 95W Continental ContiSportContact		
		8" x 18"	245/40ZR 18 97Y Pirelli P-Zero asimmetrico	size/designation	Standard and Sport
		4" x 16"	T145/80R 16 105M General (temporary spare wheel)	size/designation	All

Note: * Only fitted to USA and Canadian cars, limited to 195 km/h (121 mile/h).

Note: As tire fitment can vary in individual markets, consult the vehicle handbook or tire label for further information.

Notes

VIN		Wheel	Tire	Tire Unique Identifier	Vehicle / Chassis Specification
From	To				
S-TYPE: 2002.5 MY onwards					
M45255	Current	6.5" x 16"	205/60VR 16 92V Pirelli P7	size/designation	2.5L V6 only (not Sport)
		7.5" x 16"	225/55ZR 16 95W Pirelli P6000	J marked	V6 only (not Sport)
			225/55R 16 95H Bridgestone EL42 Turanza *	size/designation	
			225/55R 16 95H Continental ContiTouringContact *	J marked	
		7.5" x 17"	235/50ZR 17 96Y Pirelli P6000 Powergy	size/designation	V6 and V8 (not Supercharged)
			235/50R 17 96H Michelin MXM4 *	size/designation	
			235/50ZR 17 96W Pirelli P-Zero	size/designation	
		8" x 18"	245/40ZR 18 97Y Pirelli P-Zero	size/designation	V8 Supercharged
			245/40ZR 18 Continental ContiSportContact	J marked	
		9.5" x 18"	275/35ZR 18 Continental ContiSportContact	J marked	
4" x 16"	T145/80R 16 Continental (temporary spare wheel)	size/designation	V6 only		
4" x 18"	T115/85R 18 Pirelli (temporary spare wheel)	size/designation	V8, V8 SC and Sport		

Note: * Only fitted to USA and Canadian cars, limited to 195 km/h (121 mile/h).

Note: Using an unspecified wheel size may affect the calibration of the speedometer (this applies to S-TYPE 2002.5 MY onwards, and X-TYPE only).

Note: As tire fitment can vary in individual markets, consult the vehicle handbook or tire label for further information.

Notes

VIN		Wheel	Tire	Tire Unique Identifier	Vehicle / Chassis Specification
From	To				
X-TYPE: 2001.5 MY onwards					
C00344	Current	6.5" x 16" steel	205/55R 16 91H * Continental ContiTouringContact CH95	J marked	Standard US markets
			205/55R 16 91V Pirelli P6000 Powergy	J marked	Standard OSNA markets
		6.5" x 16" alloy	205/55R 16 91H * Continental ContiTouringContact CH95	J marked	Standard US markets
			205/55R 16 91V Pirelli P6000 Powergy	J marked	Standard OSNA markets
		7" x 17"	225/45R 17 91Y Pirelli P-Zero	size/designation/ no yellow P-Zero label	Sport and Standard OSNA markets
			225/45R 17 94W Continental ContiSportContact	J marked/size/designation	
			225/45R 17 91H * Continental ContiTouringContact CH95	J marked	Sport and Standard US markets
			205/50R 17 93Y Pirelli P-Zero Rosso	size/designation	Sport and Standard 2.0 liter gasoline – OSNA
		7.5" x 18"	225/40ZR 18 92W Pirelli P-Zero Nero	size/designation	Sport and Standard
		4" x 16"	T125/85R 16 99M Pirelli (temporary spare wheel)	size/designation	All

Note: * Only fitted to USA and Canadian cars, limited to 195 km/h (121 mile/h).

Note: Using an unspecified wheel size may affect the calibration of the speedometer (this applies to S-TYPE 2002.5 MY onwards, and X-TYPE only).

Note: As tire fitment can vary in individual markets, consult the vehicle handbook or tire label for further information.

VIN		Wheel	Tire	Tire Unique Identifier	Vehicle / Chassis Specification
From	To				
XJ: 2003.5 MY onwards					
G00442	Current	7.5" x 17"	235/55R 17 Continental TS790	-	All naturally aspirated vehicles
		8" x 18"	235/50R 18 Continental TS790	-	All naturally aspirated and supercharged vehicles
		8" x 18"	235/50R 18 Pirelli Snowsport	-	All naturally aspirated and supercharged vehicles
XK: 1997 MY onwards					
001246	Current	8" x 17"	245/50R 17 Pirelli Snowsport	-	All naturally aspirated vehicles
		8" x 18" Front	245/45R 18 Pirelli Snowsport	-	All naturally aspirated and supercharged vehicles
		9" x 18" Rear			
		8.5" x 18" All wheels	245/45R 18 Pirelli Snowsport	-	All naturally aspirated and supercharged vehicles

Notes

VIN		Wheel	Tire	Tire Unique Identifier	Vehicle / Chassis Specification
From	To				
S-TYPE: 2002.5 MY onwards					
Excluding "R" Model					
M45255	Current	7" or 7.5" x 16"	225/55R 16 Pirelli Snowsport	-	Naturally aspirated vehicles with 300 mm front disc only
		7" or 7.5" x 16"	225/55R 16 Continental TS790	-	Naturally aspirated vehicles with 300 mm front disc only
		7.5" x 17"	235/50R 17 Pirelli Snowsport	-	All naturally aspirated vehicles
		7.5" x 17"	235/50R 17 Continental TS790	-	All naturally aspirated vehicles
"R" Model only					
		8" x 18"	235/40R 18 front Pirelli Snowsport	-	"R" Models only
		9.5" x 18"	265/35R 18 rear Pirelli Snowsport	-	"R" Models only
X-TYPE: 2001.5 MY onwards					
C00344	Current	6.5" x 16"	205/55R 16 Pirelli Snowsport	-	All vehicles
		6.5" x 16"	205/55R 16 Continental TS790	-	All vehicles
		7" x 17"	225/45R 17 Pirelli Snowsport	-	All vehicles
		7" x 17"	225/45R 17 Continental TS790	-	All vehicles
		7" x 17"	205/50R 17 Pirelli Snowsport	-	All vehicles
		7.5" x 18"	225/40R 18 Continental TS790	-	All vehicles
		7.5" x 18"	225/40R 18 Pirelli Snowsport	-	All vehicles

Model and Model Year	VIN		Tire Size	Tire Pressures – cold bar (lbf/in ²)		<u>Notes</u>
	From	To		Front	Rear	
XJ: 1998 up to 2000 MY						
Normal: speeds above 160 km/h – 100 mile/h	812317	878717	16 inch	2.2 (32)	2.3 (34)	
			17 inch	2.2 (32)	2.3 (34)	
			18 inch	2.2 (32)	2.3 (34)	
Comfort: speeds below 160 km/h – 100 mile/h			16 inch	1.8 (26)	1.9 (28)	
			17 inch	1.8 (26)	1.9 (28)	
			18 inch	1.8 (26)	1.9 (28)	
Maximum Speed 80 km/h – 50 mile/h			3.5 x 18 inch (temporary spare wheel)	4.2 (60)	4.2 (60)	

Model and Model Year	VIN		Tire Size	Tire Pressures – cold bar (lbf/in ²)		Notes
	From	To		Front	Rear	
XJ: 2000 up to 2003.5 MY						
Normal: speeds above 160 km/h – 100 mile/h	F00103	F59525	16 inch	2.2 (32)	2.3 (34)	
			17 inch	2.2 (32)	2.3 (34)	
			18 inch	2.2 (32)	2.3 (34)	
			19 inch	2.3 (34)	2.6 (38)	
Comfort: speeds below 160 km/h – 100 mile/h			16 inch	1.8 (26)	1.9 (28)	
			17 inch	1.8 (26)	1.9 (28)	
			18 inch	1.8 (26)	1.9 (28)	
			19 inch	2.2 (32)	2.4 (35)	
Maximum Speed 80 km/h – 50 mile/h			3.5 x 18 and 4 x 18 inch (temporary spare wheel)	4.2 (60)	4.2 (60)	

Model and Model Year	VIN		Tire Size	Tire Pressures – cold					
	From	To		USA and Canada		ROW excluding *		Markets *	
				bar (lbf/in ²)		bar (lbf/in ²)		bar (lbf/in ²)	
			Front	Rear	Front	Rear	Front	Rear	
Xj: 2003.5 MY onwards									
Normal: speeds above 160 km/h – 100 mile/h	G00442	Current	17 inch	2.1 (30)	2.2 (32)	2.2 (32)	2.3 (34)	–	–
			18 inch	2.1 (30)	2.2 (32)	2.5 (36)	2.6 (38)	2.5 (36)	2.6 (38)
			19 inch	2.2 (32)	2.3 (34)	2.2 (32)	2.3 (34)	2.2 (32)	2.3 (34)
			20 inch	2.3 (34)	2.5 (36)	2.3 (34)	2.5 (36)	2.3 (34)	2.5 (36)
Comfort: speeds below 160 km/h – 100 mile/h			17 inch	1.9 (28)	2.1 (30)	1.9 (28)	2.1 (30)	–	–
			18 inch	1.9 (28)	2.1 (30)	1.9 (28)	2.1 (30)	2.5 (36)	2.6 (38)
			19 inch	1.9 (28)	2.1 (30)	1.9 (28)	2.1 (30)	2.2 (32)	2.3 (34)
			20 inch	2.2 (32)	2.3 (34)	2.2 (32)	2.3 (34)	2.3 (34)	2.5 (36)
Maximum Speed 80 km/h – 50 mile/h			4" x 18" (temporary spare wheel)	4.2 (60)					

* Argentina, Brazil, Chile, Dominican Republic, Estonia, Morocco, Panama, Philippines, Russia, Sri Lanka.

Notes

Model and Model Year	VIN		Tire Size	Tire Pressures – cold bar (lbf/in ²)		Notes
	From	To		Front	Rear	
XK: 1997 up to 1998.75 MY						
Normal: speeds above 160 km/h – 100 mile/h	001246	024686	17 inch	2.2 (32)	2.3 (34)	
			18 inch tire date code pre “048”	2.2 (32)	2.1 (30)	
			18 inch tire date code “048” on	2.2 (32)	2.3 (34)	
Comfort: speeds below 160 km/h – 100 mile/h			17 inch	1.8 (26)	1.9 (28)	
			18 inch tire date code pre “048”	1.8 (26)	1.6 (24)	
			18 inch tire date code “048” on	1.8 (26)	1.9 (28)	
Maximum Speed 80 km/h – 50 mile/h			3.5 x 18 (temporary spare wheel)	4.2 (60)	4.2 (60)	
XK: 1998.75 up to 2000 MY						
Normal: speeds above 160 km/h – 100 mile/h	024687	042775	17 inch	2.2 (32)	2.3 (34)	
			18 inch	2.2 (32)	2.3 (34)	
Comfort: speeds below 160 km/h – 100 mile/h			17 inch	1.8 (26)	1.9 (28)	
			18 inch	1.8 (26)	1.9 (28)	
Maximum Speed 80 km/h – 50 mile/h			3.5 x 18 (temporary spare wheel)	4.2 (60)	4.2 (60)	

Model and Model Year	VIN		Tire Size	Tire Pressures – cold bar (lb/in ²)		Notes
	From	To		Front	Rear	
XK: 2000 MY onwards						
Normal: speeds above 160 km/h – 100 mile/h	A00116	Current	17 inch	2.2 (32)	2.3 (34)	
			18 inch	2.2 (32)	2.3 (34)	
			19 inch	2.2 (32)	2.3 (34)	
			20 inch	2.2 (32)	2.1 (30)	
Comfort: speeds below 160 km/h – 100 mile/h			17 inch	1.8 (26)	1.9 (28)	
			18 inch	1.8 (26)	1.9 (28)	
			19 inch	2.2 (32)	2.3 (34)	
			20 inch	2.2 (32)	2.1 (30)	
Maximum Speed 80 km/h – 50 mile/h			3.5 x 18 and 4 x 18 inch (temporary spare wheel)	4.2 (60)	4.2 (60)	

Model and Model Year	VIN		Tire Size	Tire Pressures – cold bar (lbf/in ²)		Notes
	From	To		Front	Rear	
S-TYPE: 1999.25 MY						
Normal: speeds above 160 km/h – 100 mile/h	L00600	L31320	16 inch	2.2 (32)	2.3 (34)	
			17 inch	2.2 (32)	2.3 (34)	
Comfort: speeds below 160 km/h – 100 mile/h			16 inch	1.8 (26)	1.9 (28)	
			17 inch	1.8 (26)	1.9 (28)	
Maximum Speed 80 km/h – 50 mile/h			4 x 16 inch (temporary spare wheel)	4.2 (60)	4.2 (60)	
S-TYPE: 2000 up to 2002.5 MY						
Normal: speeds above 160 km/h – 100 mile/h	L31321	M45254	16 inch	2.2 (32)	2.3 (34)	
			17 inch	2.2 (32)	2.3 (34)	
			18 inch	2.2 (32)	2.3 (34)	
Comfort: speeds below 160 km/h – 100 mile/h			16 inch	1.8 (26)	1.9 (28)	
			17 inch	1.8 (26)	1.9 (28)	
			18 inch	1.8 (26)	1.9 (28)	
Maximum Speed 80 km/h – 50 mile/h			4 x 16 inch (temporary spare wheel)	4.2 (60)	4.2 (60)	

Model and Model Year	VIN		Tire Size	Tire Pressures – cold bar (lb/in ²)		Notes
	From	To		Front	Rear	
S-TYPE: 2002.5 MY onward						
Excluding “R” Model	M45255	Current				
Up to 4 People (any speed)			205/60R 16	2.2 (32)	2.2 (32)	
			225/55R 16	2.1 (31)	2.1 (31)	
			235/50R 17	2.1 (31)	2.1 (31)	
			245/40R 18	2.1 (31)	2.1 (31)	
5 People and Luggage (any speed)			205/60R 16	2.7 (39)	2.7 (39)	
			225/55R 16	2.6 (38)	2.6 (38)	
			235/50R 17	2.6 (38)	2.6 (38)	
			245/40R 18	2.4 (35)	2.4 (35)	
Maximum Speed 80 km/h – 50 mile/h			T145/80R 16 and T115/85R 18	4.2 (60)	4.2 (60)	
“R” Model only						
Normal: speeds above 160 km/h – 100 mile/h			245/40R 18	2.5 (36)	–	
			275/35R 18	–	2.8 (40)	
Comfort: speeds below 160 km/h – 100 mile/h			245/40R 18	1.9 (28)	–	
			275/35R 18	–	2.2 (32)	
Maximum Speed 80 km/h – 50 mile/h			T115/85R 18	4.2 (60)	4.2 (60)	

Model and Model Year	VIN		Tire Size	Tire Pressures – cold bar (lbf/in ²)		Notes
	From	To		Front	Rear	
X-TYPE: 2001.5 MY onwards (continued over)						
2.5 and 3.0 liter only	C00344	Current				
Normal: speeds above 160 km/h – 100 mile/h			16 inch	2.6 (38)	2.4 (35)	
			17 inch 225/45 R17 91Y	2.6 (38)	2.4 (35)	
			17 inch 225/45 R17 94W	2.6 (38)	2.4 (35)	
			18 inch 225/40 R18	2.6 (38)	2.4 (35)	
Comfort: speeds below 160 km/h – 100 mile/h			16 inch	2.2 (32)	2.2 (32)	
			17 inch 225/45 R17 91Y	2.1 (30)	2.1 (30)	
			17 inch 225/45 R17 94W	2.3 (34)	2.3 (34)	
			18 inch 225/40 R18	2.3 (34)	2.2 (32)	
Maximum Speed 80 km/h – 50 mile/h			4 x 16 inch (temporary spare wheel)	4.2 (60)	4.2 (60)	

Model and Model Year	VIN		Tire Size	Tire Pressures – cold bar (lb/in ²)		Notes
	From	To		Front	Rear	
X-TYPE: 2001.5 MY onwards (continued)						
2.0 liter gasoline only	C00344	Current				
Normal: speeds above 160 km/h – 100 mile/h			16 inch	2.4 (35)	2.2 (32)	
			17 inch	2.5 (36)	2.3 (34)	
Comfort: speeds below 160 km/h – 100 mile/h			16 inch	2.1 (30)	2.1 (30)	
			17 inch	2.3 (34)	2.3 (34)	
Maximum Speed 80 km/h – 50 mile/h			4 x 16 inch (temporary spare wheel)	4.2 (60)	4.2 (60)	
2.0 liter diesel only						
Normal: speeds above 160 km/h – 100 mile/h			16 inch	2.4 (35)	2.2 (32)	
			17 inch	2.5 (36)	2.3 (34)	
Comfort: speeds below 160 km/h – 100 mile/h			16 inch	2.2 (32)	2.1 (30)	
			17 inch	2.2 (32)	2.1 (30)	
Maximum Speed 80 km/h – 50 mile/h			4 x 16 inch (temporary spare wheel)	4.2 (60)	4.2 (60)	

Model and Model Year	VIN		Tire Size	Tire Pressures – cold bar (lb/in ²)		Notes
	From	To		Front	Rear	
XJ: 2003.5 MY onwards	G00442	Current				
Winter tires with the same dimensions as Original Equipment (OE) tires use the same tire pressures as the OE tires. Refer to “Tire Pressures (Original Equipment)” section.						
XK: 1997 MY onwards	001246	Current				
Winter tires with the same dimensions as Original Equipment (OE) tires use the same tire pressures as the OE tires. Refer to “Tire Pressures (Original Equipment)” section.						
S-TYPE: 2002.5 MY onward	M45255	Current				
Excluding “R” Model						
Winter tires with the same dimensions as Original Equipment (OE) tires use the same tire pressures as the OE tires. Refer to “Tire Pressures (Original Equipment)” section.						
“R” Model only						
Normal: speeds above 160 km/h – 100 mile/h			8" x 18"	2.6 (38)	–	
			9.5" x 18"	–	2.9 (42)	
Comfort: speeds below 160 km/h – 100 mile/h			8" x 18"	2.1 (31)	–	
			9.5" x 18"	–	2.3 (34)	
X-TYPE: 2001.5 MY onwards	C00344	Current				
Winter tires with the same dimensions as Original Equipment (OE) tires use the same tire pressures as the OE tires. Refer to “Tire Pressures (Original Equipment)” section.						
Note: The vehicle speed should be restricted to 210 km/h (130 mile/h) when “H” rated tires are fitted, or 240 km/h (149 mile/h) when “V” rated tires are fitted.						

Model/Model Year	VIN		Market	Showroom mm (inch)		Curb mm (inch)		<u>Notes</u>
	From	To		Front	Rear	Front	Rear	
XJ: 1998 up to 2003.5 MY								
Comfort Suspension	812317	F59525	All	390 (15.35)	384 (15.11)	389 (15.31)	373 (14.68)	
Sport Suspension			All	389 (15.31)	381 (15.00)	388 (15.27)	372 (14.64)	
XJR			NAS	389 (15.31)	382 (15.03)	388 (15.27)	372 (14.64)	
XJR			ROW	367 (14.44)	365 (14.37)	366 (14.40)	358 (14.09)	
Supercharged Super 8			All	389 (15.31)	382 (15.03)	388 (15.27)	372 (14.64)	

- Ride height is measured from the center of the wheel to the apex of the wheel arch, through the wheel center line.
- Showroom = with all fluids at full and 9 liters (9.5 US Quarts) of fuel.
- Curb = with all fluids at full and a full tank of fuel.
- All figures quoted assume ± 15 mm (0.59 inch) anticipated build variance and condition.

Model/Model Year	VIN		Market	Standard Ride Height mm		<u>Notes</u>
	From	To		Front	Rear	
XJ: 2003.5 MY onwards						
	G00442	Current	All	386	373	

- Ride height is measured from the center of the wheel to the apex of the wheel arch, through the wheel center line.
- Ride heights quoted are as attained after the vehicle has been leveled using the WDS Pre-Geometry function. Once leveled, the figures quoted assume ± 15 mm anticipated build variance and condition.
- Ride height calibration can only be performed using WDS.
- Due to WDS calibration, metric figures are quoted only.

Model/Model Year	VIN		Market	Showroom mm (inch)		Curb mm (inch)		<u>Notes</u>
	From	To		Front	Rear	Front	Rear	
XK: 1997 MY onwards								
XK8	001246	Current	All	401 (15.78)	416 (16.37)	400 (15.74)	405 (15.94)	
XKR			All	401 (15.78)	415 (16.33)	400 (15.74)	405 (15.94)	

- Ride height is measured from the center of the wheel to the apex of the wheel arch, through the wheel center line.
- Showroom = with all fluids at full and 9 liters (9.5 US Quarts) of fuel.
- Curb = with all fluids at full and a full tank of fuel.
- All figures quoted assume \pm 15 mm (0.59 inch) anticipated build variance and condition.

Model/Model Year	VIN		Market	Showroom mm (inch)		Curb mm (inch)		Notes
	From	To		Front	Rear	Front	Rear	
S-TYPE: 1999.25 up to 2002.5 MY								
V6 Manual – Non adaptive damping	L00600	M45254	All	387 (15.23)	384 (15.11)	385 (15.15)	378 (14.88)	
V6 Manual – With adaptive damping			All	385 (15.15)	381 (15.00)	384 (15.11)	375 (14.76)	
V6 Auto – Non adaptive damping			All	386 (15.19)	384 (15.11)	384 (15.11)	378 (14.88)	
V6 Auto – With adaptive damping			All	385 (15.15)	381 (15.00)	384 (15.11)	375 (14.76)	
V8 Auto – Non adaptive damping			All	386 (15.19)	384 (15.11)	384 (15.11)	378 (14.88)	
V8 Auto – With adaptive damping			All	385 (15.15)	381 (15.00)	383 (15.07)	375 (14.76)	

- Ride height is measured from the center of the wheel to the apex of the wheel arch, through the wheel center line.
- Showroom = with all fluids at full and 9 liters (9.5 US Quarts) of fuel.
- Curb = with all fluids at full and a full tank of fuel.
- All figures quoted assume \pm 15 mm (0.59 inch) anticipated build variance and condition.

Model/Model Year	VIN		Market	Showroom mm (inch)		Curb mm (inch)		Notes
	From	To		Front	Rear	Front	Rear	
S-TYPE: 2002.5 MY onwards								
V6 Manual – Non adaptive damping	M45255	Current	All	392 (15.43)	389 (15.31)	390 (15.35)	382 (15.03)	
V6 Manual – With adaptive damping			All	389 (15.31)	384 (15.11)	387 (15.23)	378 (14.88)	
V6 Auto – Non adaptive damping			All	392 (15.43)	389 (15.31)	390 (15.35)	382 (15.03)	
V6 Auto – With adaptive damping			All	389 (15.31)	384 (15.11)	387 (15.23)	378 (14.88)	
V8 N/A Auto – Non adaptive damping			All	390 (15.35)	389 (15.31)	388 (15.27)	382 (15.03)	
V8 N/A Auto – With adaptive damping			All	387 (15.23)	384 (15.11)	386 (15.19)	378 (14.88)	
V8 SC Auto – With adaptive damping			All	387 (15.23)	384 (15.11)	386 (15.19)	378 (14.88)	

- Showroom = with all fluids at full and 9 liters (9.5 US quarts) of fuel.
- Curb = with all fluids at full and a full tank of fuel.
- Ride height is measured from the center of the wheel to the apex of the wheel arch, through the wheel center line.
- All figures quoted assume ± 15 mm (0.59 inch) anticipated build variance and condition.

Model/Model Year	VIN		Market	Showroom mm (inch)		Curb mm (inch)		<u>Notes</u>
	From	To		Front	Rear	Front	Rear	
X-TYPE: 2001.5 MY onwards								
Comfort Suspension (2.5 and 3.0 liter)	C00344	Current	All	376 (14.80)	379 (14.92)	374 (14.72)	372 (14.64)	
Sport Suspension (2.5 and 3.0 liter)			All	375 (14.76)	375 (14.76)	373 (14.68)	369 (14.53)	
Comfort Suspension (2.0 liter)			All	379 (14.92)	382 (15.03)	377 (14.84)	375 (14.76)	
Sport Suspension (2.0 liter)			All	378 (14.88)	380 (14.96)	376 (14.80)	373 (14.68)	

- Ride height is measured from the center of the wheel to the apex of the wheel arch, through the wheel center line.
- Showroom = with all fluids at full and 9 liters (9.5 US quarts) of fuel.
- Curb = with all fluids at full and a full tank of fuel.
- All figures quoted assume ± 15 mm (0.59 inch) anticipated build variance and condition.

XJ – Camber								Notes
1998 up to 2003.5 MY VIN – 812317 to F59525		Camber						
		Left-Hand		Right-Hand		Balance (RH minus LH)		
		Min	Max	Min	Max	Min	Max	
XJR Excluding NAS, and German Daimler Super-8								
All Right-Hand Drive and Japan	Degrees/Minutes	- 1° 28'	- 0° 28'	- 1° 13'	- 0° 13'	- 0° 45'	+ 1° 15'	
	Decimal Degrees	- 1.47°	- 0.47°	- 1.22°	- 0.22°	- 0.75°	+ 1.25°	
Rest of World	Degrees/Minutes	- 1° 13'	- 0° 13'	- 1° 28'	- 0° 28'	- 1° 15'	+ 0° 45'	
	Decimal Degrees	- 1.22°	- 0.22°	- 1.47°	- 0.47°	- 1.25°	+ 0.75°	
XJR NAS, and Comfort/Sports/Daimler Super-8								
All Right-Hand Drive and Japan	Degrees/Minutes	- 1° 02'	- 0° 02'	- 0° 47'	+ 0° 13'	- 0° 45'	+ 1° 15'	
	Decimal Degrees	- 1.03°	- 0.03°	- 0.78°	+ 0.22°	- 0.75°	+ 1.25°	
USA, Canada, Mexico, Dominican Republic (NAS)	Degrees/Minutes	- 0° 32'	+ 0° 28'	- 1° 02'	- 0° 02'	- 1° 30'	+ 0° 30'	
	Decimal Degrees	- 0.53°	+ 0.47°	- 1.03°	- 0.03°	- 1.50°	+ 0.50°	
Rest of World	Degrees/Minutes	- 0° 47'	+ 0° 13'	- 1° 02'	- 0° 02'	- 1° 15'	+ 0° 45'	
	Decimal Degrees	- 0.78°	+ 0.22°	- 1.03°	- 0.03°	- 1.25°	+ 0.75°	

- All above figures are at “showroom” height – See “Vehicle Ride Heights” section.
- Tires must be inflated to normal pressure – See “Tire Pressures” sections.

XJ – Camber								Notes
2003.5 MY onwards VIN – G00442 to Current		Camber						
		Left-Hand		Right-Hand		Balance (RH minus LH)		
		Min	Max	Min	Max	Min	Max	
All Right-Hand Drive and Japan	Degrees/Minutes	- 1° 12'	- 0° 12'	- 0° 48'	+ 0° 12'	- 0° 18'	+ 1° 06'	
	Decimal Degrees	- 1.20°	- 0.20°	- 0.80°	+ 0.20°	- 0.30°	+ 1.10°	
USA, Canada, Mexico, Dominican Republic (NAS)	Degrees/Minutes	- 0° 45'	+ 0° 15'	- 1° 15'	- 0° 15'	- 1° 12'	+ 0° 12'	
	Decimal Degrees	- 0.75°	+ 0.25°	- 1.25°	- 0.25°	- 1.20°	+ 0.20°	
Rest of World	Degrees/Minutes	- 0° 54'	+ 0° 06'	- 1° 06'	- 0° 06'	- 0° 54'	+ 0° 30'	
	Decimal Degrees	- 0.90°	+ 0.10°	- 1.10°	- 0.10°	- 0.90°	+ 0.50°	

- All above figures are at “standard” height – See “Vehicle Ride Heights” section.
- Tires must be inflated to normal pressure – See “Tire Pressures” sections.

XJ – Castor								Notes
1998 up to 2003.5 MY VIN – 812317 to F59525		Castor						
		Left-Hand		Right-Hand		Balance (RH minus LH)		
		Min	Max	Min	Max	Min	Max	
XJR Excluding NAS, and German Daimler Super-8								
All Right-Hand Drive and Japan	Degrees/Minutes	+ 4° 00'	+ 8° 00'	+ 4° 00'	+ 8° 00'	- 1° 12'	+ 1° 12'	
	Decimal Degrees	+ 4.00°	+ 8.00°	+ 4.00°	+ 8.00°	- 1.20°	+ 1.20°	
Rest of World	Degrees/Minutes	+ 4° 00'	+ 8° 00'	+ 4° 00'	+ 8° 00'	- 1° 12'	+ 1° 12'	
	Decimal Degrees	+ 4.00°	+ 8.00°	+ 4.00°	+ 8.00°	- 1.20°	+ 1.20°	
XJR NAS, and Comfort/Sports/Daimler Super-8								
All Right-Hand Drive and Japan	Degrees/Minutes	+ 4° 00'	+ 8° 00'	+ 4° 00'	+ 8° 00'	- 1° 12'	+ 1° 12'	
	Decimal Degrees	+ 4.00°	+ 8.00°	+ 4.00°	+ 8.00°	- 1.20°	+ 1.20°	
USA, Canada, Mexico, Dominican Republic (NAS)	Degrees/Minutes	+ 4° 00'	+ 8° 00'	+ 4° 00'	+ 8° 00'	- 1° 12'	+ 1° 12'	
	Decimal Degrees	+ 4.00°	+ 8.00°	+ 4.00°	+ 8.00°	- 1.20°	+ 1.20°	
Rest of World	Degrees/Minutes	+ 4° 00'	+ 8° 00'	+ 4° 00'	+ 8° 00'	- 1° 12'	+ 1° 12'	
	Decimal Degrees	+ 4.00°	+ 8.00°	+ 4.00°	+ 8.00°	- 1.20°	+ 1.20°	

- All above figures are at “showroom” height – See “Vehicle Ride Heights” section.
- Tires must be inflated to normal pressure – See “Tire Pressures” sections.

XJ – Castor								<u>Notes</u>
2003.5 MY onwards VIN – G00442 to Current		Castor						
		Left-Hand		Right-Hand		Balance (RH minus LH)		
		Min	Max	Min	Max	Min	Max	
All Right-Hand Drive and Japan	Degrees/Minutes	+ 6° 52'	+ 8° 16'	+ 6° 20'	+ 7° 44'	- 1° 14'	+ 0° 10'	
	Decimal Degrees	+ 6.87°	+ 8.27°	+ 6.34°	+ 7.74°	- 1.20°	+ 0.20°	
USA, Canada, Mexico, Dominican Republic (NAS)	Degrees/Minutes	+ 6° 47'	+ 8° 11'	+ 6° 47'	+ 8° 11'	- 0° 42'	+ 0° 42'	
	Decimal Degrees	+ 6.78°	+ 8.18°	+ 6.78°	+ 8.18°	- 0.70°	+ 0.70°	
Rest of World	Degrees/Minutes	+ 6° 47'	+ 8° 11'	+ 6° 47'	+ 8° 11'	- 0° 42'	+ 0° 42'	
	Decimal Degrees	+ 6.78°	+ 8.18°	+ 6.78°	+ 8.18°	- 0.70°	+ 0.70°	

- All above figures are at “standard” height – See “Vehicle Ride Heights” section.
- Tires must be inflated to normal pressure – See “Tire Pressures” sections.

Notes

XJ – Toe			
1998 up to 2003.5 MY VIN – 812317 to F59525		Total Toe	
		Min	Max
XJR Excluding NAS, and German Daimler Super-8			
All Right-Hand Drive and Japan	Degrees/Minutes	+ 0° 05'	+ 0° 25'
	Decimal Degrees	+ 0.08°	+ 0.42°
Rest of World	Degrees/Minutes	+ 0° 05'	+ 0° 25'
	Decimal Degrees	+ 0.08°	+ 0.42°
XJR NAS, and Comfort/Sports/Daimler Super-8			
All Right-Hand Drive and Japan	Degrees/Minutes	+ 0° 05'	+ 0° 25'
	Decimal Degrees	+ 0.08°	+ 0.42°
USA, Canada, Mexico, Dominican Republic (NAS)	Degrees/Minutes	+ 0° 05'	+ 0° 25'
	Decimal Degrees	+ 0.08°	+ 0.42°
Rest of World	Degrees/Minutes	+ 0° 05'	+ 0° 25'
	Decimal Degrees	+ 0.08°	+ 0.42°

- All above figures are at “showroom” height – See “Vehicle Ride Heights” section.
- Tires must be inflated to normal pressure – See “Tire Pressures” sections.

XJ – Toe			
2003.5 MY onwards VIN – G00442 to Current		Total Toe	
		Min	Max
All Right-Hand Drive and Japan	Degrees/Minutes	- 0° 26'	- 0° 06'
	Decimal Degrees	- 0.43°	- 0.10°
USA, Canada, Mexico, Dominican Republic (NAS)	Degrees/Minutes	- 0° 26'	- 0° 06'
	Decimal Degrees	- 0.43°	- 0.10°
Rest of World	Degrees/Minutes	- 0° 26'	- 0° 06'
	Decimal Degrees	- 0.43°	- 0.10°

Notes

- All above figures are at “standard” height – See “Vehicle Ride Heights” section.
- Tires must be inflated to normal pressure – See “Tire Pressures” sections.

XK – Camber							
1997 MY onwards VIN – 001246 to Current		Camber					
		Left-Hand		Right-Hand		Balance (RH minus LH)	
		Min	Max	Min	Max	Min	Max
All Right-Hand Drive and Japan	Degrees/Minutes	- 1° 17'	- 0° 17'	- 0° 45'	+ 0° 14'	- 0° 11'	+ 1° 13'
	Decimal Degrees	- 1.28°	- 0.28°	- 0.76°	+ 0.24°	- 0.19°	+ 1.21°
USA, Canada, Mexico, Dominican Republic (NAS)	Degrees/Minutes	- 1° 11'	- 0° 11'	- 1° 18'	- 0° 18'	- 0° 50'	+ 0° 34'
	Decimal Degrees	- 1.18°	- 0.18°	- 1.30°	- 0.30°	- 0.83°	+ 0.57°
Rest of World	Degrees/Minutes	- 1° 14'	- 0° 14'	- 1° 17'	- 0° 17'	- 0° 44'	+ 0° 40'
	Decimal Degrees	- 1.24°	- 0.24°	- 1.28°	- 0.28°	- 0.74°	+ 0.66°

Notes

- All above figures are at “showroom” height – See “Vehicle Ride Heights” section.
- Tires must be inflated to normal pressure – See “Tire Pressures” sections.

XK – Castor							
1997 MY onwards VIN – 001246 to Current		Castor					
		Left-Hand		Right-Hand		Balance (RH minus LH)	
		Min	Max	Min	Max	Min	Max
All Right-Hand Drive and Japan	Degrees/Minutes	+ 6° 28'	+ 7° 52'	+ 6° 20'	+ 7° 44'	- 0° 50'	+ 0° 34'
	Decimal Degrees	+ 6.47°	+ 7.87°	+ 6.33°	+ 7.73°	- 0.84°	+ 0.57°
USA, Canada, Mexico, Dominican Republic (NAS)	Degrees/Minutes	+ 5° 52'	+ 7° 16'	+ 6° 38'	+ 8° 02'	+ 0° 04'	+ 1° 28'
	Decimal Degrees	+ 5.87°	+ 7.27°	+ 6.64°	+ 8.04°	+ 0.06°	+ 1.46°
Rest of World	Degrees/Minutes	+ 6° 15'	+ 7° 39'	+ 6° 28'	+ 7° 52'	- 0° 29'	+ 0° 55'
	Decimal Degrees	+ 6.25°	+ 7.65°	+ 6.47°	+ 7.87°	- 0.49°	+ 0.91°

Notes

- All above figures are at “showroom” height – See “Vehicle Ride Heights” section.
- Tires must be inflated to normal pressure – See “Tire Pressures” sections.

XK – Toe			
1997 MY onwards VIN – 001246 to Current		Total Toe	
		Min	Max
All Right-Hand Drive and Japan	Degrees/Minutes	+ 0° 05'	+ 0° 25'
	Decimal Degrees	+ 0.08°	+ 0.42°
USA, Canada, Mexico, Dominican Republic (NAS)	Degrees/Minutes	+ 0° 05'	+ 0° 25'
	Decimal Degrees	+ 0.08°	+ 0.42°
Rest of World	Degrees/Minutes	+ 0° 05'	+ 0° 25'
	Decimal Degrees	+ 0.08°	+ 0.42°

Notes

- All above figures are at “showroom” height – See “Vehicle Ride Heights” section.
- Tires must be inflated to normal pressure – See “Tire Pressures” sections.

S-TYPE – Camber								Notes
1999.25 up to 2002.5 MY VIN – L00600 to M45254		Camber						
		Left-Hand		Right-Hand		Balance (RH minus LH)		
		Min	Max	Min	Max	Min	Max	
All Right-Hand Drive and Japan	Degrees/Minutes	-0° 45'	+0° 15'	-0° 33'	+0° 27'	-0° 30'	+0° 54'	
	Decimal Degrees	-0.75°	+0.25°	-0.55°	+0.45°	-0.50°	+0.90°	
USA, Canada, Mexico, Dominican Republic (NAS)	Degrees/Minutes	-0° 30'	+0° 30'	-1° 06'	-0° 06'	-1° 18'	+0° 06'	
	Decimal Degrees	-0.50°	+0.50°	-1.10°	-0.10°	-1.30°	+0.10°	
Rest of World	Degrees/Minutes	-0° 33'	+0° 27'	-0° 45'	+0° 15'	-0° 54'	+0° 30'	
	Decimal Degrees	-0.55°	+0.45°	-0.75°	+0.25°	-0.90°	+0.50°	
2002.5 MY onwards VIN – M45255 to Current								
All Right-Hand Drive and Japan	Degrees/Minutes	-0° 54'	+0° 06'	-0° 42'	+0° 18'	-0° 30'	+0° 54'	
	Decimal Degrees	-0.90°	+0.10°	-0.70°	+0.30°	-0.50°	+0.90°	
USA, Canada, Mexico, Dominican Republic (NAS)	Degrees/Minutes	-0° 33'	+0° 27'	-1° 03'	-0° 03'	-1° 12'	+0° 12'	
	Decimal Degrees	-0.55°	+0.45°	-1.05°	-0.05°	-1.20°	+0.20°	
Rest of World	Degrees/Minutes	-0° 42'	+0° 18'	-0° 54'	+0° 06'	-0° 54'	+0° 30'	
	Decimal Degrees	-0.70°	+0.30°	-0.90°	+0.10°	-0.90°	+0.50°	

- All above figures are at “Showroom” height – See “Vehicle Ride Heights” section.
- Tires must be inflated to:
 - “normal” setting up to 2002.5 MY and
 - “up to 4 people” setting 2002.5 MY onwards – See “Tire Pressures” sections.

S-TYPE – Castor								Notes
1999.25 up to 2002.5 MY VIN – L00600 to M45254		Castor						
		Left-Hand		Right-Hand		Balance (RH minus LH)		
		Min	Max	Min	Max	Min	Max	
All Right-Hand Drive and Japan	Degrees/Minutes	+ 7° 06'	+ 8° 30'	+ 7° 06'	+ 8° 30'	- 0° 42'	+ 0° 42'	
	Decimal Degrees	+ 7.10°	+ 8.50°	+ 7.10°	+ 8.50°	- 0.70°	+ 0.70°	
USA, Canada, Mexico, Dominican Republic (NAS)	Degrees/Minutes	+ 7° 06'	+ 8° 30'	+ 7° 06'	+ 8° 30'	- 0° 42'	+ 0° 42'	
	Decimal Degrees	+ 7.10°	+ 8.50°	+ 7.10°	+ 8.50°	- 0.70°	+ 0.70°	
Rest of World	Degrees/Minutes	+ 7° 06'	+ 8° 30'	+ 7° 06'	+ 8° 30'	- 0° 42'	+ 0° 42'	
	Decimal Degrees	+ 7.10°	+ 8.50°	+ 7.10°	+ 8.50°	- 0.70°	+ 0.70°	
2002.5 MY onwards VIN – M45255 to Current								
All Right-Hand Drive and Japan	Degrees/Minutes	+ 6° 48'	+ 8° 12'	+ 6° 48'	+ 8° 12'	- 0° 42'	+ 0° 42'	
	Decimal Degrees	+ 6.80°	+ 8.20°	+ 6.80°	+ 8.20°	- 0.70°	+ 0.70°	
USA, Canada, Mexico, Dominican Republic (NAS)	Degrees/Minutes	+ 6° 48'	+ 8° 12'	+ 6° 48'	+ 8° 12'	- 0° 42'	+ 0° 42'	
	Decimal Degrees	+ 6.80°	+ 8.20°	+ 6.80°	+ 8.20°	- 0.70°	+ 0.70°	
Rest of World	Degrees/Minutes	+ 6° 48'	+ 8° 12'	+ 6° 48'	+ 8° 12'	- 0° 42'	+ 0° 42'	
	Decimal Degrees	+ 6.80°	+ 8.20°	+ 6.80°	+ 8.20°	- 0.70°	+ 0.70°	

- All above figures are at “Showroom” height – See “Vehicle Ride Heights” section.
- Tires must be inflated to:
 - “normal” setting up to 2002.5 MY and
 - “up to 4 people” setting 2002.5 MY onwards – See “Tire Pressures” sections.

S-TYPE – Toe			
1999.25 up to 2002.5 MY VIN – L00600 to M45254		Total Toe	
		Min	Max
All Right-Hand Drive and Japan	Degrees/Minutes	0° 00'	+ 0° 20'
	Decimal Degrees	0.00°	+ 0.34°
USA, Canada, Mexico, Dominican Republic (NAS)	Degrees/Minutes	0° 00'	+ 0° 20'
	Decimal Degrees	0.00°	+ 0.34°
Rest of World	Degrees/Minutes	0° 00'	+ 0° 20'
	Decimal Degrees	0.00°	+ 0.34°

Notes

S-TYPE – Toe			
2002.5 MY onwards VIN – M45255 to Current		Total Toe	
		Min	Max
All Right-Hand Drive and Japan	Degrees/Minutes	- 0° 22'	- 0° 02'
	Decimal Degrees	- 0.37°	- 0.03°
USA, Canada, Mexico, Dominican Republic (NAS)	Degrees/Minutes	- 0° 22'	- 0° 02'
	Decimal Degrees	- 0.37°	- 0.03°
Rest of World	Degrees/Minutes	- 0° 22'	- 0° 02'
	Decimal Degrees	- 0.37°	- 0.03°

- All figures are at “Showroom” height. See “Vehicle Ride Heights” section.
- Tires must be inflated to:
 - “normal” setting up to 2002.5 MY and
 - “up to 4 people” setting 2002.5 MY onwards
 - See “Tire Pressures” sections.

X-TYPE – Camber

Notes

2001.5 MY onwards VIN – C00344 to Current		Camber					
		Left-Hand		Right-Hand		Balance (RH minus LH)	
		Min	Max	Min	Max	Min	Max
All Markets	Degrees/Minutes	- 1° 02'	- 0° 02'	- 1° 02'	- 0° 02'	- 0° 42'	+ 0° 42'
	Decimal Degrees	- 1.04°	- 0.04°	- 1.04°	- 0.04°	- 0.70°	+ 0.70°

- All above figures are with 20 liters of fuel.
- Tires must be inflated to normal pressure – See “Tire Pressures” sections.

X-TYPE – Castor

2001.5 MY onwards VIN – C00344 to Current		Castor					
		Left-Hand		Right-Hand		Balance (RH minus LH)	
		Min	Max	Min	Max	Min	Max
All Markets	Degrees/Minutes	+ 1° 59'	+ 2° 59'	+ 1° 59'	+ 2° 59'	- 0° 30'	+ 0° 30'
	Decimal Degrees	+ 1.98°	+ 2.98°	+ 1.98°	+ 2.98°	- 0.50°	+ 0.50°

- All above figures are with 20 liters of fuel.
- Tires must be inflated to normal pressure – See “Tire Pressures” sections.

X-TYPE – Toe

2001.5 MY onwards VIN – C00344 to Current		Total Toe	
		Min	Max
All Markets	Degrees/Minutes	- 0° 16'	+ 0° 04'
	Decimal Degrees	- 0.27°	+ 0.07°

Notes

- All above figures are with 20 liters of fuel.
- Tires must be inflated to normal pressure – See “Tire Pressures” sections.

XJ – Camber								Notes
1998 up to 2003.5 MY VIN – 812317 to F59525		Camber						
		Left-Hand		Right-Hand		Balance (RH minus LH)		
		Min	Max	Min	Max	Min	Max	
All Markets	Degrees/Minutes	- 1° 12'	- 0° 06'	- 1° 12'	- 0° 06'	- 1° 00'	+ 1° 00'	
	Decimal Degrees	- 1.20°	- 0.10°	- 1.20°	- 0.10°	- 1.00°	+ 1.00°	
2003.5 MY onwards VIN – G00442 to Current								
All Markets	Degrees/Minutes	- 1° 38'	- 0° 08'	- 1° 38'	- 0° 08'	- 0° 45'	+ 0° 45'	
	Decimal Degrees	- 1.64°	- 0.14°	- 1.64°	- 0.14°	- 0.75°	+ 0.75°	

- 1998 up to 2003.5 MY figures are at “showroom” height – See “Vehicle Ride Heights” section.
- 2003.5 MY onwards figures are at “standard” height – See “Vehicle Ride Heights” section.
- Tires must be inflated to normal pressure – See “Tire Pressures” sections.

XJ – Toe										Notes
1998 up to 2003.5 MY VIN – 812317 to F59525		Toe								
		Left-Hand		Right-Hand		Total Toe		Thrust Angle		
		Min	Max	Min	Max	Min	Max	Min	Max	
All Markets	Degrees/Minutes	+ 0° 5'	+ 0° 15'	+ 0° 5'	+ 0° 15'	+ 0° 10'	+ 0° 30'	- 0° 05'	+ 0° 05'	
	Decimal Degrees	+ 0.08°	+ 0.25°	+ 0.08°	+ 0.25°	+ 0.17°	+ 0.50°	- 0.08°	+ 0.08°	
2003.5 MY onwards VIN – G00442 to Current										
All Markets	Degrees/Minutes	- 0° 01'	+ 0° 11'	- 0° 01'	+ 0° 11'	0° 00'	+ 0° 20'	- 0° 06'	+ 0° 06'	
	Decimal Degrees	- 0.02°	+ 0.18°	- 0.02°	+ 0.18°	0.00°	+ 0.33°	- 0.10°	+ 0.10°	

- 1998 up to 2003.5 MY figures are at “showroom” height – See “Vehicle Ride Heights” section.
- 2003.5 MY onwards figures are at “standard” height – See “Vehicle Ride Heights” section.
- Tires must be inflated to normal pressure – See “Tire Pressures” sections.

XK – Camber							
1997 MY onwards VIN – 001246 to Current		Camber					
		Left-Hand		Right-Hand		Balance (RH minus LH)	
		Min	Max	Min	Max	Min	Max
All Markets	Degrees/Minutes	- 0° 54'	- 0° 06'	- 0° 54'	- 0° 06'	- 1° 00'	+ 1° 00'
	Decimal Degrees	- 0.90°	- 0.10°	- 0.90°	- 0.10°	- 1.00°	+ 1.00°

Notes

- All above figures are at “showroom” height – See “Vehicle Ride Heights” section.
- Tires must be inflated to normal pressure – See “Tire Pressures” sections.

XK – Toe									
1997 MY onwards VIN – 001246 to Current		Toe							
		Left-Hand		Right-Hand		Total Toe		Thrust Angle	
		Min	Max	Min	Max	Min	Max	Min	Max
All Markets	Degrees/Minutes	+ 0° 5'	+ 0° 15'	+ 0° 5'	+ 0° 15'	+ 0° 10'	+ 0° 30'	- 0° 05'	+ 0° 05'
	Decimal Degrees	+ 0.08°	+ 0.25°	+ 0.08°	+ 0.25°	+ 0.17°	+ 0.50°	- 0.08°	+ 0.08°

- All above figures are at “showroom” height – See “Vehicle Ride Heights” section.
- Tires must be inflated to normal pressure – See “Tire Pressures” sections.

S-TYPE – Camber								Notes
1999.25 up to 2002.5 MY VIN – L00600 to M45254		Camber						
		Left-Hand		Right-Hand		Balance (RH minus LH)		
		Min	Max	Min	Max	Min	Max	
All Markets	Degrees/Minutes	- 1° 45'	- 0° 15'	- 1° 45'	- 0° 15'	- 0° 45'	+ 0° 45'	
	Decimal Degrees	- 1.75°	- 0.25°	- 1.75°	- 0.25°	- 0.75°	+ 0.75°	
2002.5 MY onwards VIN – M45255 to Current								
All Markets	Degrees/Minutes	- 1° 17'	+ 0° 13'	- 1° 17'	+ 0° 13'	- 0° 45'	+ 0° 45'	
	Decimal Degrees	- 1.29°	+ 0.21°	- 1.29°	+ 0.21°	- 0.75°	+ 0.75°	

- All above figures are at “Showroom” height – See “Vehicle Ride Heights” section.
- Tires must be inflated to:
 - “normal” setting up to 2002.5 MY and
 - “up to 4 people” setting 2002.5 MY onwards – See “Tire Pressures” sections.

S-TYPE – Toe										Notes
1999.25 up to 2002.5 MY VIN – L00600 to M45254		Toe								
		Left-Hand		Right-Hand		Total Toe		Thrust Angle		
		Min	Max	Min	Max	Min	Max	Min	Max	
All Markets	Degrees/Minutes	+ 0° 01'	+ 0° 13'	+ 0° 01'	+ 0° 13'	+ 0° 05'	+ 0° 25'	- 0° 06'	+ 0° 06'	
	Decimal Degrees	+ 0.02°	+ 0.22°	+ 0.02°	+ 0.22°	+ 0.08°	+ 0.42°	- 0.10°	+ 0.10°	
2002.5 MY onwards VIN – M45255 to Current										
All Markets (Normally Aspirated)	Degrees/Minutes	- 0° 01'	+ 0° 11'	- 0° 01'	+ 0° 11'	0° 00'	+ 0° 20'	- 0° 06'	+ 0° 06'	
	Decimal Degrees	- 0.02°	+ 0.18°	- 0.02°	+ 0.18°	0.00°	+ 0.33°	- 0.10°	+ 0.10°	
All Markets (Supercharged)	Degrees/Minutes	+ 0° 02'	+ 0° 14'	+ 0° 02'	+ 0° 14'	+ 0° 05'	+ 0° 25'	- 0° 06'	+ 0° 06'	
	Decimal Degrees	+ 0.03°	+ 0.23°	+ 0.03°	+ 0.23°	+ 0.08°	+ 0.42°	- 0.10°	+ 0.10°	

- All above figures are at “Showroom” height – See “Vehicle Ride Heights” section.
- Tires must be inflated to:
 - “normal” setting up to 2002.5 MY and
 - “up to 4 people” setting 2002.5 MY onwards – See “Tire Pressures” sections.

Notes

X-TYPE – Camber							
2001.5 MY onwards VIN – C00344 to Current		Camber					
		Left-Hand		Right-Hand		Balance (RH minus LH)	
		Min	Max	Min	Max	Min	Max
All Markets	Degrees/Minutes	- 1° 12'	- 0° 12'	- 1° 12'	- 0° 12'	- 0° 30'	+ 0° 30'
	Decimal Degrees	- 1.20°	- 0.20°	- 1.20°	- 0.20°	- 0.50°	+ 0.50°

- All above figures are with 20 liters of fuel.
- Tires must be inflated to normal pressure – See “Tire Pressures” sections.

X-TYPE – Toe									
2001.5 MY onwards VIN – C00344 to Current		Toe							
		Left-Hand		Right-Hand		Total Toe		Thrust Angle	
		Min	Max	Min	Max	Min	Max	Min	Max
All Markets	Degrees/Minutes	+ 0° 2'	+ 0° 14'	+ 0° 2'	+ 0° 14'	+ 0° 05'	+ 0° 25'	- 0° 06'	+ 0° 06'
	Decimal Degrees	+ 0.03°	+ 0.23°	+ 0.03°	+ 0.23°	+ 0.08°	+ 0.42°	- 0.10°	+ 0.10°

- All above figures are with 20 liters of fuel.
- Tires must be inflated to normal pressure – See “Tire Pressures” sections.

Model	Model Year		VIN		Nut Torque Aluminium-Wheel		Nut Torque Steel-Wheel		<u>Notes</u>
	From	To	From	To	Nm	lbf ft	Nm	lbf ft	
XJ									
	1998	1999	812317	878717	88 – 102	65 – 75	68 – 82	50 – 60	
	2000	2003.5	F00103	F59525	88 – 102	65 – 75	–	–	
	2003.5	Onwards	G00442	Current	115 – 135	85 – 100	–	–	
XK									
	1997	1999	001246	042775	88 – 102	65 – 75	68 – 82	50 – 60	
	2000	Onwards	A00116	Current	88 – 102	65 – 75	–	–	
S-TYPE									
	1999.25	Onwards	L00600	Current	115 – 135	85 – 100	–	–	
X-TYPE									
	2001.5	Onwards	C00344	Current	88 – 118	65 – 87	68 – 92	50 – 68	

Component	Torque	<u>Notes</u>
Air Temperature Sensor (supercharge only)	35 Nm	
Camshaft Bearing Cap	10 Nm	
Camshaft Sensor	7 Nm	
Charge – Air Cooler Adapter	21 Nm	
Charge – Air Cooler to adaptor	12 Nm	
Coolant Pump	8 Nm + 90 degrees	
Crankshaft Damper Pulley – Bolt	375 Nm	
Crankshaft Position Sensor	7 Nm	
Cylinder Head Bolts	See: Tightening Torques and Sequence – Cylinder Heads Section.	
Cylinder Head Cover	10 Nm	

To convert Nm to lbf ft:
Divide the Nm torque figure by 1.356

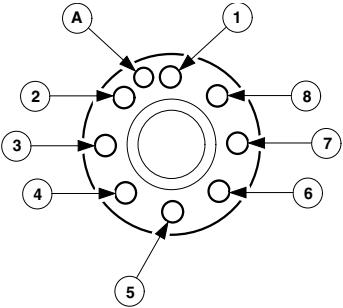
Component	Torque	Notes
Drive Plate  <p style="text-align: right; margin-right: 50px;">J.303.1563</p>	A = Dowel 1. Tighten to 15 Nm in order: 1, 5, 3, 7, 2, 6, 4, 8. 2. Tighten to 110 Nm in order: 1, 5, 3, 7, 2, 6, 4, 8.	
Engine Mounting Bracket to Engine	40 Nm	
Exhaust Manifold	See: Tightening Torques and Sequence – Intake and Exhaust Manifolds Section.	
Ignition Coil	5 Nm	
Intake Manifold	See: Tightening Torques and Sequence – Intake and Exhaust Manifolds Section.	
Knock Sensor	10 Nm (stud) / 20 Nm (nut)	
Oil Diverter Valve	12 Nm	

**To convert Nm to lbf ft:
Divide the Nm torque figure by 1.356**

Component	Torque	<u>Notes</u>
Oil Filter	18 Nm exact	
Oil Filter Adapter	30 Nm	
Oil Filter Head	21 Nm	
Oil Pan	12 Nm	
Oil Pan Baffle (windage tray)	6 Nm	
Oil Pan Body to Lower Cylinder Block	21 Nm	
Oil Pick-up Pipe	12 Nm	
Oil Pressure Switch	12 Nm	
Oil Pump	12 Nm	
Oil Temperature Sensor	20 Nm	
Piston Cooling Jets	9 Nm	
Spark Plugs	28 Nm	
Starter Motor	43 Nm	
Supercharger	21 Nm	
Thermostat Cover	9 Nm	
Thermostat Housing	10 Nm	
Thermostat Housing Cap	9 Nm	

To convert Nm to lbf ft:
Divide the Nm torque figure by 1.356

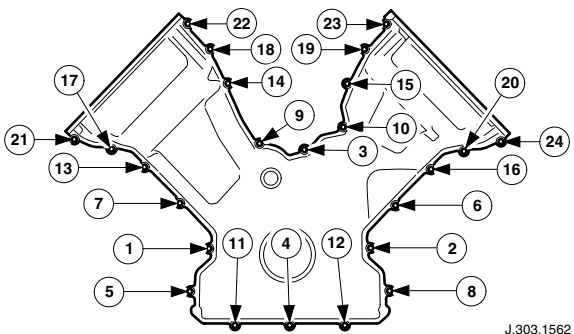
Component	Torque	Notes
<p>Timing Chain Cover</p>  <p style="text-align: right;">J.303.1562</p>	<p>12 Nm – Tighten in sequence shown.</p>	

To convert Nm to lbf ft:
 Divide the Nm torque figure by 1.356

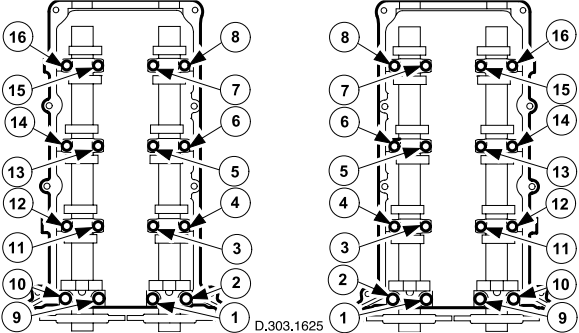
Component	Torque	Notes
Accessory Drive – Belt Tensioner	48 Nm	
Accessory Drive – Idler Pulley	25 Nm (grooved) 48 Nm (smooth X-TYPE)	
Air Conditioning Compressor	25 Nm	
Air Conditioning Compressor Mounting-Bracket	25 Nm	
Camshaft Bearing Caps  <p style="text-align: center;">Front of Engine</p>	10 Nm – Tighten in sequence shown	
Camshaft Sprocket – Exhaust	40 Nm + 90 degrees – not to exceed 215 Nm	

To convert Nm to lbf ft:
Divide the Nm torque figure by 1.356

Component	Torque	Notes
Clutch Pressure Plate	24 Nm – work across pressure plate in a diagonal pattern.	
Coolant Pump (X-TYPE)	<p>Tighten in sequence below:</p> <ul style="list-style-type: none"> • Tighten bolt (4) to 5 Nm. • Tighten bolt (5) to 5 Nm. • Tighten bolts (1) (2) (3) to 5 Nm. • Tighten bolt (4) to 10 Nm. • Tighten bolt (5) to 10 Nm. • Tighten bolts (1) (2) (3) to 10 Nm. 	
Coolant Pump (S-TYPE and X)	25 Nm	
Coolant Pump Pulley (X-TYPE)	10 Nm	

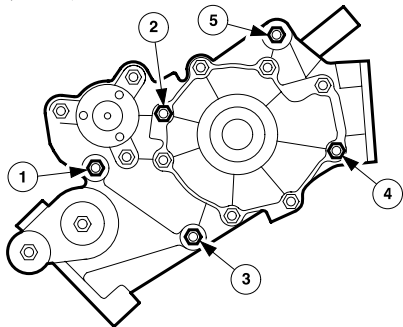

303 1749

To convert Nm to lbf ft:
 Divide the Nm torque figure by 1.356

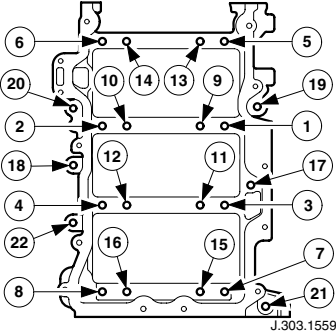
Component	Torque	Notes
Crankshaft Damper Pulley	<ol style="list-style-type: none"> 1. Pre-torque to 120 Nm. 2. Loosen Bolt 360 degrees. 3. Torque to 50 Nm. 4. Rotate Bolt Clockwise 90 degrees, to a maximum of 200 Nm. 	
Crankshaft Position Sensor	10 Nm	
Cylinder Block Lower, to Cylinder Block Upper 	Tighten in sequence below: <ol style="list-style-type: none"> 1. 1 through to 8 – tighten to 25 Nm. 2. 9 through to 16 – tighten to 40 Nm. 3. 1 through to 16 – rotate 90 degrees. 4. 17 through to 22 – tighten to 25 Nm. 	
Cylinder Head Bolts	See: Tightening Torques and Sequence – Cylinder Heads Section.	

To convert Nm to lbf ft:
Divide the Nm torque figure by 1.356

Component	Torque	<u>Notes</u>
Cylinder Head Cover	10 Nm	
Cylinder Head Temperature Sensor	15 Nm	
Exhaust Manifold	See: Tightening Torques and Sequence – Intake and Exhaust Manifolds Section.	
Generator	48 Nm (25 Nm X-TYPE lower bolt)	
Ignition Coil	7 Nm	
Intake Air Control Valve	10 Nm	
Intake Manifold – Lower	10 Nm	
Intake Manifold – Upper	See: Tightening Torques and Sequence – Intake and Exhaust Manifolds Section.	
Knock Sensor	25 Nm	
Oil Cooler	58 Nm	
Oil Filter	14 to 17 Nm	
Oil Filter and Engine Mounting Assembly	Tighten in sequence below: <ol style="list-style-type: none"> 1. Tighten M22 bolt to 30 Nm. 2. Tighten M10 bolt to 26 Nm. 3. Tighten M8 bolt to 26 Nm. 4. Tighten M22 bolt to 155 Nm. 5. Tighten M10 bolt to 40 Nm and then rotate 90 degrees. 	
Oil Gauge Tube	10 Nm	
Oil Pan Baffle	5 Nm and then rotate 45 degrees, not to exceed 17 Nm	

To convert Nm to lbf ft:
Divide the Nm torque figure by 1.356

Component	Torque	Notes
Oil Pan Drain Plug	23 Nm	
Oil Pan to Cylinder Block	25 Nm	
Oil Pick-up Pipe	bolt – 10 Nm nut – 5 Nm + 45 degrees, not to exceed 17 Nm	
Oil Pressure Switch	14 Nm	
Oil Pump to Cylinder Block	10 Nm	
Oil Separator to Cylinder Block (S-TYPE)	10 Nm	
Oil Temperature Sensor	14 Nm	
Power Steering Idler – Pulley Bracket	25 Nm	
Power Steering Pump	25 Nm	
Spark Plugs	15 Nm	
Throttle Body	10 Nm	

To convert Nm to lbf ft:
Divide the Nm torque figure by 1.356

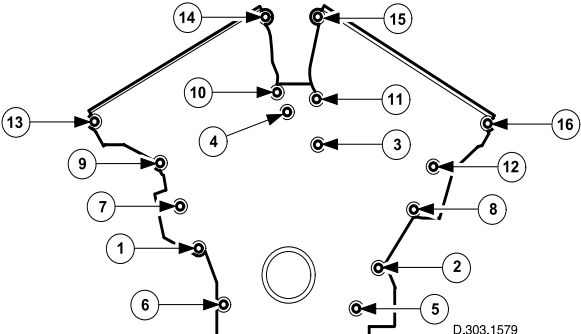
Component	Torque	Notes
<p>Timing Chain Cover</p>  <p>D.303.1579</p>	<p>25 Nm – Tighten in sequence shown.</p> <p>X-TYPE only bolts 3, 4, 10, 11 30 Nm + 45 degrees</p>	

To convert Nm to lbf ft:
Divide the Nm torque figure by 1.356

Component	Torque	<u>Notes</u>
Accessory Drive (rear) – Tensioner	23 Nm	
Camshaft Position Sensor	9 Nm	
Camshaft Pulley (rear)	64 Nm	
Camshaft Sprocket	33 Nm	
Coolant Pump	23 Nm	
Crankshaft Position Sensor	7 Nm	
Crankshaft Sprocket	36 Nm	
Cylinder Head Bolts	See: Tightening Torques and Sequence – Cylinder Heads Section.	
Cylinder Head Cover	10 Nm	
Cylinder Head Temperature Sensor	11 Nm	
EGR Cooler to Manifold	37 Nm	
Fuel High-Pressure Pump	22 Nm	
Fuel High-Pressure Pump Sprocket	33 Nm	
Fuel Injectors	47 Nm	
Glow Plug	13 Nm	
Knock Sensor	20 Nm	
Oil Filter / Cooler to Engine Block	23 Nm	
Oil Filter Cap	23 Nm	
Oil Filter Drain Plug	10 Nm	

**To convert Nm to lbf ft:
Divide the Nm torque figure by 1.356**

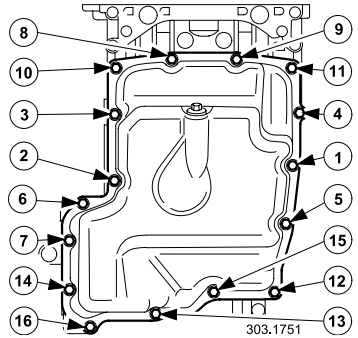
Component	Torque	Notes
<p>Oil Pan</p> 	<p>Pre-torque to 7 Nm and tighten to 14 Nm in sequence shown.</p>	
Oil Pan Drain Plug	23 Nm	
Oil Pick-up Pipe	10 Nm	
Oil Pressure Switch	15 Nm	
Oil Pump	10 Nm	
Piston Cooling Jet	10 Nm	
Power Steering Pump to Coolant Pump	18 Nm	

To convert Nm to lbf ft:
 Divide the Nm torque figure by 1.356

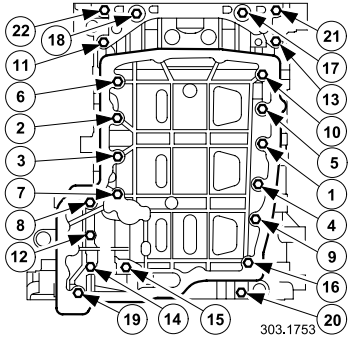
Component	Torque	Notes
Rocker Shaft	13 Nm + 45 degrees (always use new bolts)	
Stiffening frame 	23 Nm – Tighten in sequence shown.	
Thermostat Housing to Vacuum Pump	23 Nm	
Timing Chain Guides	16 Nm	
Timing Chain Tensioner	14 Nm	
Timing Chain Tensioner Blade	14 Nm	
Vacuum Pump to Engine	23 Nm	

To convert Nm to lbf ft:
Divide the Nm torque figure by 1.356

V8 Engine

Tightening Torques in Nm and Degrees of Rotation

Cylinder head bolts can be used twice, for reference purposes mark for re-use.

Step Apply each step in sequence shown:

1	Tighten bolts 1 to 10 to 20 Nm
2	Tighten bolts 1 to 10 to 35 Nm
3	Tighten bolts 1 to 10, 90 degrees
4	Tighten bolts 1 to 10, 90 degrees
5	Tighten bolts marked Y to 23 Nm

Notes

Bank 1

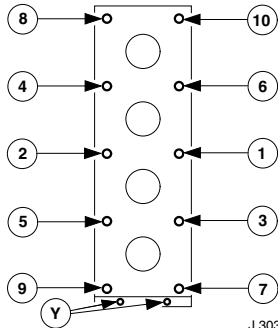

J.303.1544

front of engine

Bank 2

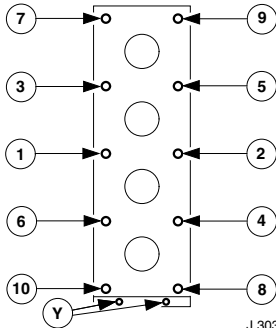

J.303.1545

To convert Nm to lbf ft:
Divide the Nm torque figure
by 1.356

Notes

V6 Engine

Tightening Torques in Nm and Degrees of Rotation

Use new bolts and washers.

Step Apply each step in sequence shown to both cylinder heads.

1	Tighten to 30 Nm
2	Tighten 90 degrees
3	Loosen 360 degrees
4	Tighten to 30 Nm
5	Tighten 90 degrees
6	Tighten 90 degrees

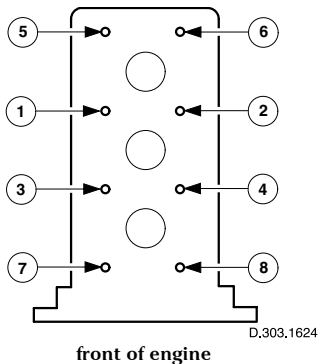

To convert Nm to lbf ft:
Divide the Nm torque figure by 1.356

2.0 Liter Diesel Engine

Notes

Tightening Torques in Nm and Degrees of Rotation

Use new bolts.

Step	Apply each step in sequence shown.	Step	
1	Bolts 1 through 10 to 10 Nm	5	Bolts 1 through 10 to 40 Nm
2	Bolts 11 through 18 to 5 Nm	6	Bolts 11 through 18 to 20 Nm
3	Bolts 1 through 10 to 20 Nm	7	Bolts 1 through 10 to 180 degrees
4	Bolts 11 through 18 to 10 Nm	8	Bolts 11 through 18 to 180 degrees

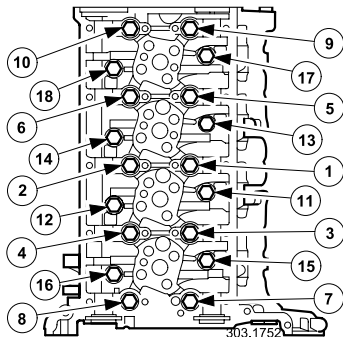

front of engine

To convert Nm to lbf ft:
Divide the Nm torque figure by 1.356

V8 Engine

Notes

LH Exhaust Manifold

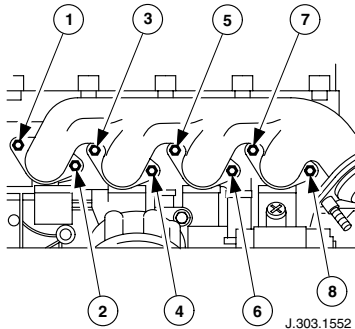

- Slightly tighten bolts 5 and 6 to align manifold
- Tighten bolts in sequence shown to 20 Nm
- Tighten nuts in sequence shown to 25 Nm

RH Exhaust Manifold

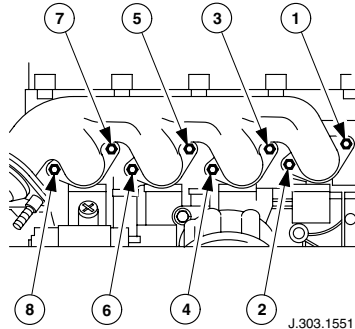

- Slightly tighten bolts 5 and 6 to align manifold
- Tighten bolts in sequence shown to 20 Nm
- Tighten nuts in sequence shown to 25 Nm

Intake Manifold

21 Nm

To convert Nm to lbf ft:
Divide the Nm torque figure by 1.356

V6 (S-TYPE and XJ) Engine

Notes

LH Exhaust Manifold

RH Exhaust Manifold

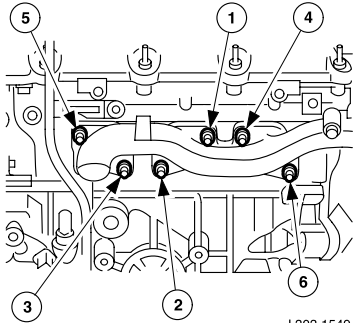

J.303.1549

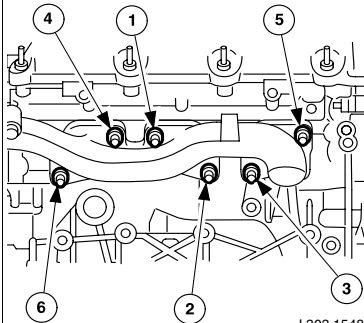

J.303.1548

1. Tighten studs to 10 Nm
2. Tighten nuts in sequence shown to 20 Nm

1. Tighten studs to 10 Nm
2. Tighten nuts in sequence shown to 20 Nm

**To convert Nm to lbf ft:
Divide the Nm torque figure by 1.356**

Notes

V6 (S-TYPE and XJ) Engine

Intake Manifold up to 2002.5 MY

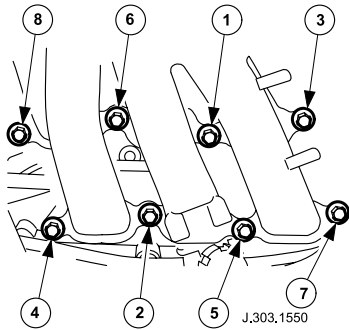

1. Tighten in sequence shown to 10 Nm

Intake Manifold 2002.5 MY onwards

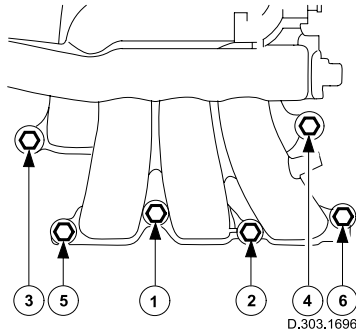

1. Tighten in sequence shown to 10 Nm

To convert Nm to lbf ft:
Divide the Nm torque figure by 1.356

V6 (X-TYPE) Engine

Notes

LH Exhaust Manifold

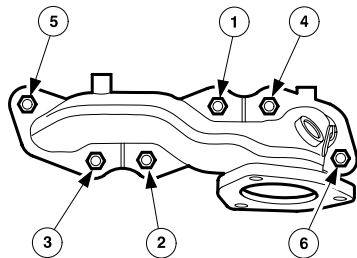

D.303.1585

1. Tighten studs to 10 Nm
2. Tighten nuts in sequence shown to 20 Nm

RH Exhaust Manifold

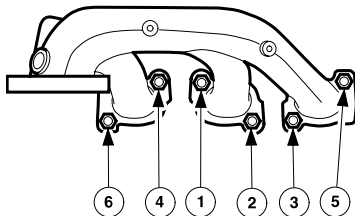

D.303.1584

1. Tighten studs to 10 Nm
2. Tighten nuts in sequence shown to 20 Nm

Intake Manifold

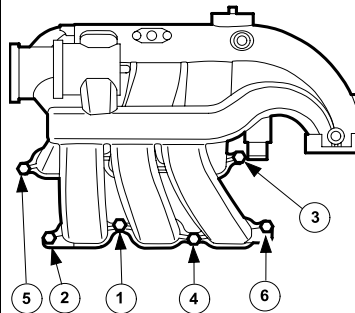

D.303.1623

1. Tighten in sequence shown to 10 Nm

(Use same sequence for the 2.0 liter gasoline engine manifold)

To convert Nm to lbf ft:
Divide the Nm torque figure by 1.356

2.0 Liter Diesel (X-TYPE) EngineNotes

Intake Manifold	15 Nm
Exhaust Manifold	40 Nm

To convert Nm to lbf ft:
Divide the Nm torque figure by 1.356

V8 (XJ and XK, also S-TYPE 2002.5 MY onwards)

Notes

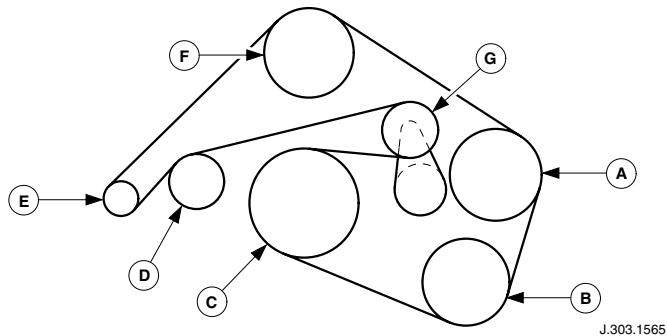

- A = Power Steering Pump
- B = Air Conditioning Compressor
- C = Crankshaft Pulley
- D = Idler

- E = Generator
- F = Water Pump
- G = Tensioner

V8 (S-TYPE up to 2002.5 MY)

Notes

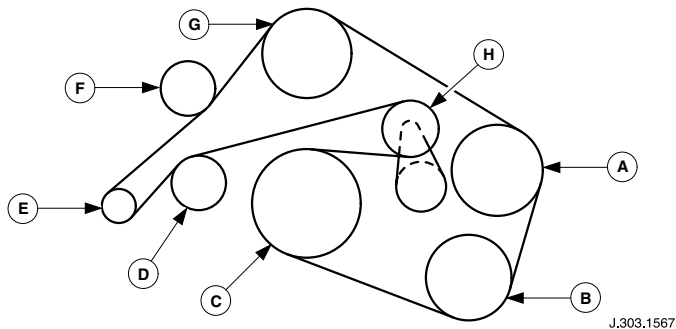

- A = Power Steering Pump
- B = Air Conditioning Compressor
- C = Crankshaft Pulley
- D = Idler

- E = Generator
- F = Idler
- G = Water Pump
- H = Tensioner

V8 Supercharged (XJ and XK, also S-TYPE 2002.5 MY onwards)

Notes

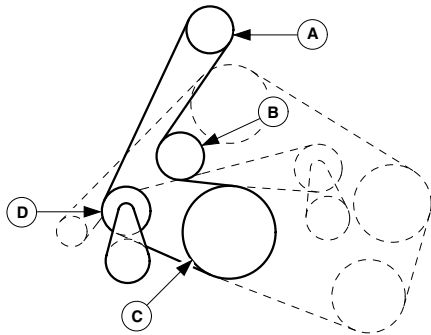

J.303.1566

- A = Supercharger
- B = Idler
- C = Crankshaft Pulley
- D = Tensioner

V6 (S-TYPE and X)

Notes

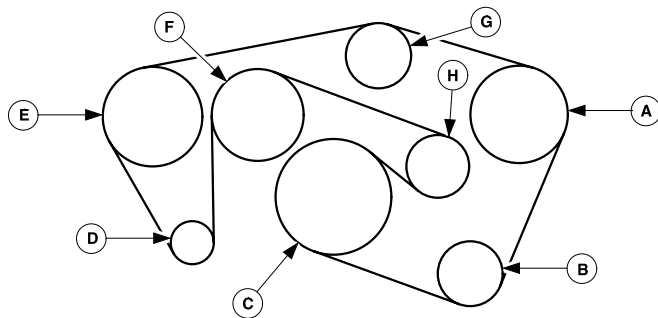

J.303.1564

- A = Power Steering Pump
- B = Air Conditioning Compressor
- C = Crankshaft Pulley
- D = Generator

- E = Idler Pulley
- F = Water Pump
- G = Idler Pulley
- H = Tensioner

V6 (X-TYPE)

Notes

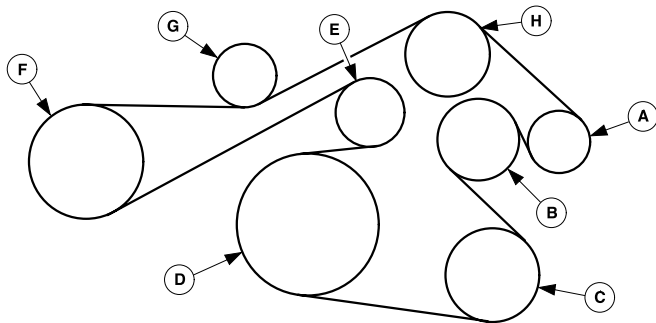

D.303.1591

- | | |
|--|--------------------------------|
| A = Generator | E = Tensioner |
| B = Idler Pulley | F = Power Steering Pump |
| C = Air Conditioning Compressor | G = Idler Pulley |
| D = Crankshaft Pulley | H = Idler Pulley |

2.0 Liter Diesel (X-TYPE)

Notes

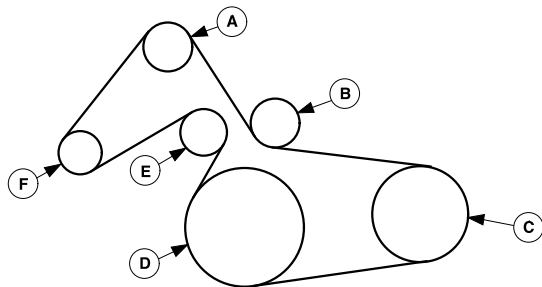

303.1755

A = Idler pulley
 B = Idler pulley
 C = Compressor pulley

D = Crankshaft pulley
 E = Tensioner pulley
 F = Generator pulley

The illustrations, technical information, data and descriptive text in this issue, to the best of our knowledge, were correct at the time of going to print.

No part of this publication may be copied, reproduced, stored in a data processing system, nor transmitted by electronic, mechanical, photographic or any other means. The storage or translation of this publication and the editing, in summary or expanded form is not permitted except with prior written permission of Jaguar Cars Ltd. The same conditions apply to parts of this publication and their use in other publications.

No liability can be accepted for any inaccuracies or omissions in this publication, although every possible care has been taken to make it as complete and accurate as possible.

Issued by:
Jaguar Cars Ltd
Technical Support and Communications
Browns Lane
Coventry
CV5 9DR

