

JAGUAR

# Parts Catalogue

---

## The New XK Range 2007 Model Year

Whilst every effort is made to ensure the accuracy of the particulars contained in this catalogue the Manufacturing companies will not, in any circumstances, be held liable for any inaccuracies or the consequences thereof.

© Jaguar Cars Ltd 2007

All rights reserved. No part of this publication may be reproduced, stored in a retrieval system or transmitted in any form, whether by electronic, mechanical, photocopying, recording or other means without the permission of Jaguar Cars limited.

Replacement parts that are not of genuine jaguar supply cannot be relied upon to be of correct specification, material, and workmanship and therefore Jaguar cannot be expected to extend warranty to vehicles which have been fitted with parts not supplied by them.

Jaguar reserves the right to make changes or improvements in the construction or specification of their products at any time.

IN ORDER TO ENSURE PROMPT AND CORRECT EXECUTION OF YOUR ORDERS, IT IS ESSENTIAL TO QUOTE:

1. The relative unit number, together with prefixes, suffixes and specification references where applicable.  
e.g. Axle, Body, Vehicle Identification, Engine, Gearbox Numbers etc.
2. The Part Number and description (prefix and suffix letters to part numbers must always be quoted).
3. Always state the colour of carpets, painted items, trim items etc., using the colour code from the Vehicle Identification Number (VIN) plate and the colour combination key to identify the colour name.
4. The quantity required, bearing in mind that the quantities shown are those used in the application actually illustrated. Sometimes only minimum package quantities are available. These packs may well contain more parts than are required for a single job; for details of packaged quantities, see the Service Parts List.

THE LISTING OR ILLUSTRATING OF AN ITEM DOES NOT  
GUARANTEE ITS AVAILABILITY

# Geographical Groupings

---

Where appropriate, applications for individual markets are displayed on the parts list section of the EPC window if there is more than one choice. If there is only one choice it is displayed in the “Attributes/Change Points” text box.

For convenience markets are sometimes categorised in to geographical groups.

**Definitions of the geographical groups used in this catalogue are as follows:**

Rough Road Markets	Argentina, Australia, Bahrain, Brazil, Chile, Dominican Republic, Dubai, Egypt, Estonia, Israel, Jordan, Kuwait, Lebanon, Malaysia, Mexico, Morocco, New Zealand, Oman, Panama, Philippines, Russia, Saudi Arabia, South Africa, Sri Lanka, Syria, Thailand
--------------------	---

# Geographical Groupings

---

- European Markets UK, Ireland, Malta, Cyprus, Germany, Poland, Austria, Italy, France, Spain, Portugal, Belgium, Luxembourg, Netherlands, Switzerland, Sweden, Denmark, Finland, Norway, Latvia, Lithuania, Estonia, Russia, Czech Republic, Hungary, Slovenia, Croatia, Slovakia, Greece, Bulgaria, Romania, Serbia, Turkey, Israel
- Hot Markets Taiwan, Singapore, Saudi Arabia, Indonesia, Philippines, Panama, Malaysia, Mexico, Egypt, Dominican Republic, Lebanon, Kuwait, Jordan, Hong Kong, Bahrain, Dubai, Turkey, Argentina, Oman, Abu Dhabi, Brazil, Brunei, Chile, Cyprus, Greece, Guatemala, Israel, Korea, Malta, Morocco, Qatar, Syria, Tenerife, Uruguay, Vietnam

# Standard Abbreviations

---

Standard abbreviations are used in this parts list as shown below:

<b>(B)</b> Body Number	<b>LHD</b> Left Hand drive
<b>(E)</b> Engine Number	<b>LWB</b> Long Wheel Base
<b>(G)</b> Gearbox Number	<b>m</b> Metres
<b>(V)</b> Vehicle Identification Number (VIN)	<b>MAP</b> Manifold Air Pressure
<b>c/w</b> Complete With	<b>MHz</b> Megahertz
<b>cm</b> Centimetre	<b>mm</b> Millimetres
<b>dia</b> Diameter	<b>MPH</b> Miles Per Hour
<b>DVD</b> Digital Versatile Disc	<b>NLA</b> No Longer Available from Jaguar Cars Ltd
<b>EGR</b> Exhaust Gas Recirculation	<b>NSP</b> Non Serviced Part
<b>EPB</b> Electronic Park Brake	<b>NSS</b> Not Supplied Separately
<b>g</b> Gram	<b>o/d</b> outside Diameter
<b>GDO</b> Garage Door Opener	<b>PCB</b> Printed Circuit Board
<b>HC</b> High Compression	<b>RH</b> Right Hand
<b>HID</b> High Intensity Discharge	<b>RHD</b> Right Hand Drive
<b>i/d</b> Inside Diameter	<b>RTV</b> Room Temperature Vulcanising
<b>kg</b> Kilogram	<b>V</b> Volts
<b>Kph</b> Kilometres per hour	<b>VDP</b> Vanden Plas
<b>LC</b> Low compression	<b>VCS</b> Vehicle Information Communication System
<b>LH</b> Left Hand	<b>W</b> Watt
<b>SDARS</b> Satellite Digital Audio Receiving System	<b>\$</b> Applicable to USA, Canada and Mexico markets only

# LOCKING FREQUENCY REGIONS

---

- **Region 1 (315mhz Low)**

Japan, South Korea

**Region 2 (315mhz High)**

Argentina, Aruba, Bahamas, Barbados, Bolivia, Brazil, Canada, Cayman, Chile, Colombia, Costa Rica, Cuba, Dominica, Ecuador, Egypt, Ethiopia, Ghana, Grenada, Guadeloupe, Guatemala, Haiti, Honduras, Hong Kong, Indonesia, Jamaica, Japan, Macau, Malaysia, Mexico, Nicaragua, Panama, Papua New Guinea, Paraguay, Peru, Philippines, Salvador, Singapore, South Korea, St. Kitts/Nevis, St. Lucia, Taiwan, Thailand, Trinidad & Tobago, Uganda, Uruguay, USA, Venezuela, Vietnam, Zimbabwe

**Region 3 (433mhz)**

Albania, Algeria, Andorra, Armenia, Australia, Austria, Azerbaijan, Bahrain, Belgium, Bosnia Herzegovina, Brunei, Bulgaria, China, Croatia, Cyprus, Czech Republic, Denmark, Estonia, Finland, France, Germany, Gibraltar, Greece, Hungary, Iceland, Iran, Ireland, Israel, Italy, Ivroy Coast, Jordan, Kazakhstan, Kenya, Kuwait, Kyrgyzstan, Latvia, Lebanon, Lithuania, Macedonia, Madagascar, Malta, Martinique, Morocco, Mozambique, Namibia, Netherlands, New Caledonia, New Zealand, Nigeria, Norway, Oman, Poland, Portugal, Qatar, Romania, Russia/Belarus, Saudi Arabia, Serbia-Montenegro, Slovakia, Slovenia, South Africa, Spain, St. Vincent & Grenadines, Sweden, Swaziland, Syria, Tahiti, Tunisia, Turkey, Turkmenistan, UK, Ukraine, United Arab Emirates, Uzbekistan

# Vehicle Identification Numbering System (Global)

---

The Vehicle Identification Number comprises a series of letters and numbers representing in code such information as Marque, Model Range, Class Engine Type etc. The codes for the New XK are as follows:

## **PREFIX 1 to 3**

### **World manufacturing Identifier**

SAJ = Jaguar

## **PREFIX 4**

### **Market & Airbag Spec**

A = Rest of World

B = Canada

D = USA

E = USA (1)

F =Canada (1)

J = USA (2)

K = Japan (1)

P = Mexico (1)

R = Mexico (2)

W = USA (3)

X = Canada (3)

Y = Mexico (3)

## **PREFIX 5**

### **Transmission & Steering**

A = Automatic LHS

C = Automatic RHS

## **PREFIX 6 & 7**

### **Body Code**

43/4D = 2 door Coupe

44/4E = 2 door Convertible

45/4F = Portfolio Coupe

46/4G = Portfolio Convertible

47 = XKR-S Coupe

## **PREFIX 8**

### **Emission**

A = ECS 1

B = ECS 2

C = ECS 3

D = ECS 4

E = ECS 5

F = ECS 6

G = ECS 7

K = ECS 10

N = ECS 13

P = ECS 14

R = ECS 15

S = ECS 16

T = ECS 17

U = ECS 18

V = ECS 19

W = ECS 20

X = ECS 21

Y = ECS 22

1 = ECS 23

2 = ECS 24

3 = ECS 25

4 = ECS 26

## **PREFIX 9**

### **Check Digit ?**

## **PREFIX 10**

### **Model or Year Change**

7 = 2007 Model Year

8 = 2008 Model Year

9 = 2009 Model Year

A = 2010 Model Year

B = 2011 Model Year

C = 2012 Model Year

D = 2013 Model Year

E = 2014 Model Year

## **PREFIX 11**

4 = Castle Bromwich 3.5V8

5 = Castle Bromwich 4.2V8

9 = Castle Bromwich 4.2V8 Supercharged

L = Castle Bromwich 5.0V8

M = Castle Bromwich 5.0V8 Supercharged

## **PREFIX 12 to 17**

### **Production Serial Number**

# Model Year VIN Introductions

---

- 2006.5MY From (V) B00379
- 2007MY From (V) B06784
- 2008MY from (V) B20075
- 2009MY from (V) B27987
- 2010MY from (V) B32753
- 2011MY from (V) B38854
- 2012MY from (V) B44940
- 2013MY from (V) B48620



# V8 Petrol Engine Serial Numbers

---

The production fit V8 engine serial number is 10 digits long and denotes production date and time.

Typical serial number example:

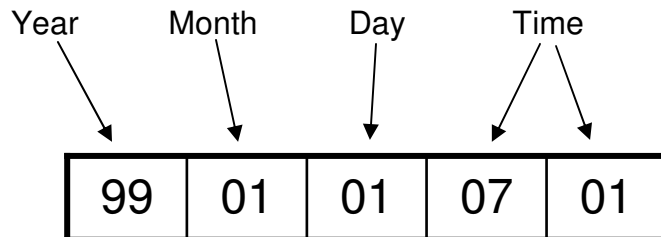

Serial number

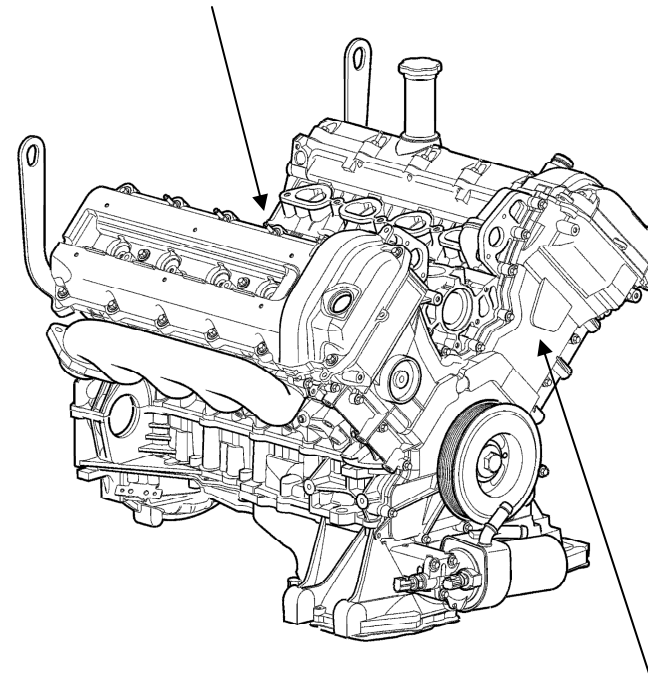

Emission label

# V8 Re-manufactured Engine Serial Numbers

---

Head gaskets and chain systems are always fitted, and therefore the ID letters will always be part of the stamping. Care must be taken with the H, P, C, B, U and V options as these may not always be used. In some cases none of the letters will be required.

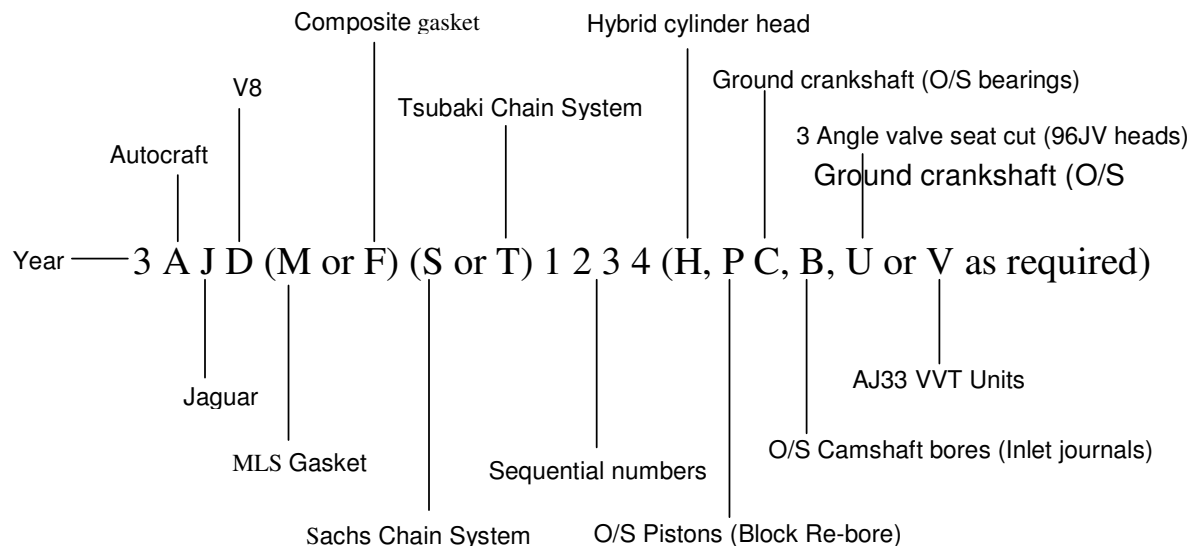

# Gearbox Serial Number

---

**Serial number**

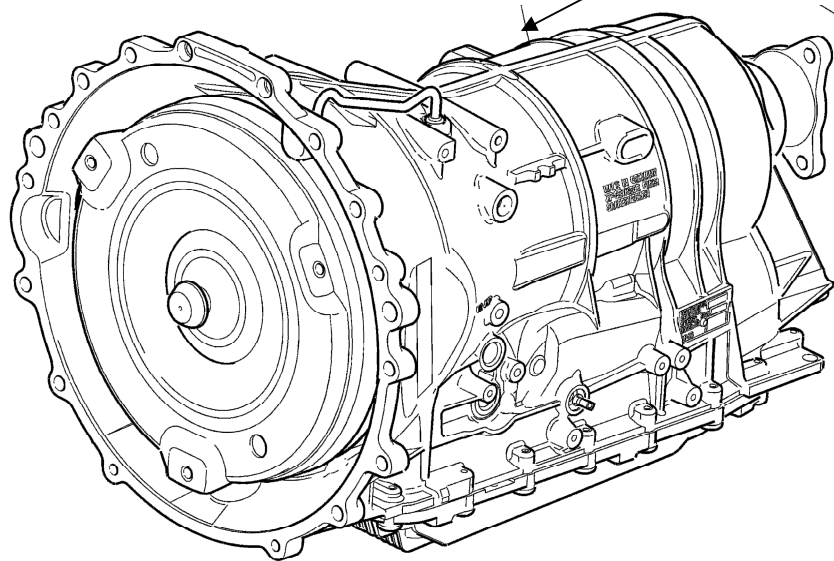

# CONTROL MODULE LOCATIONS

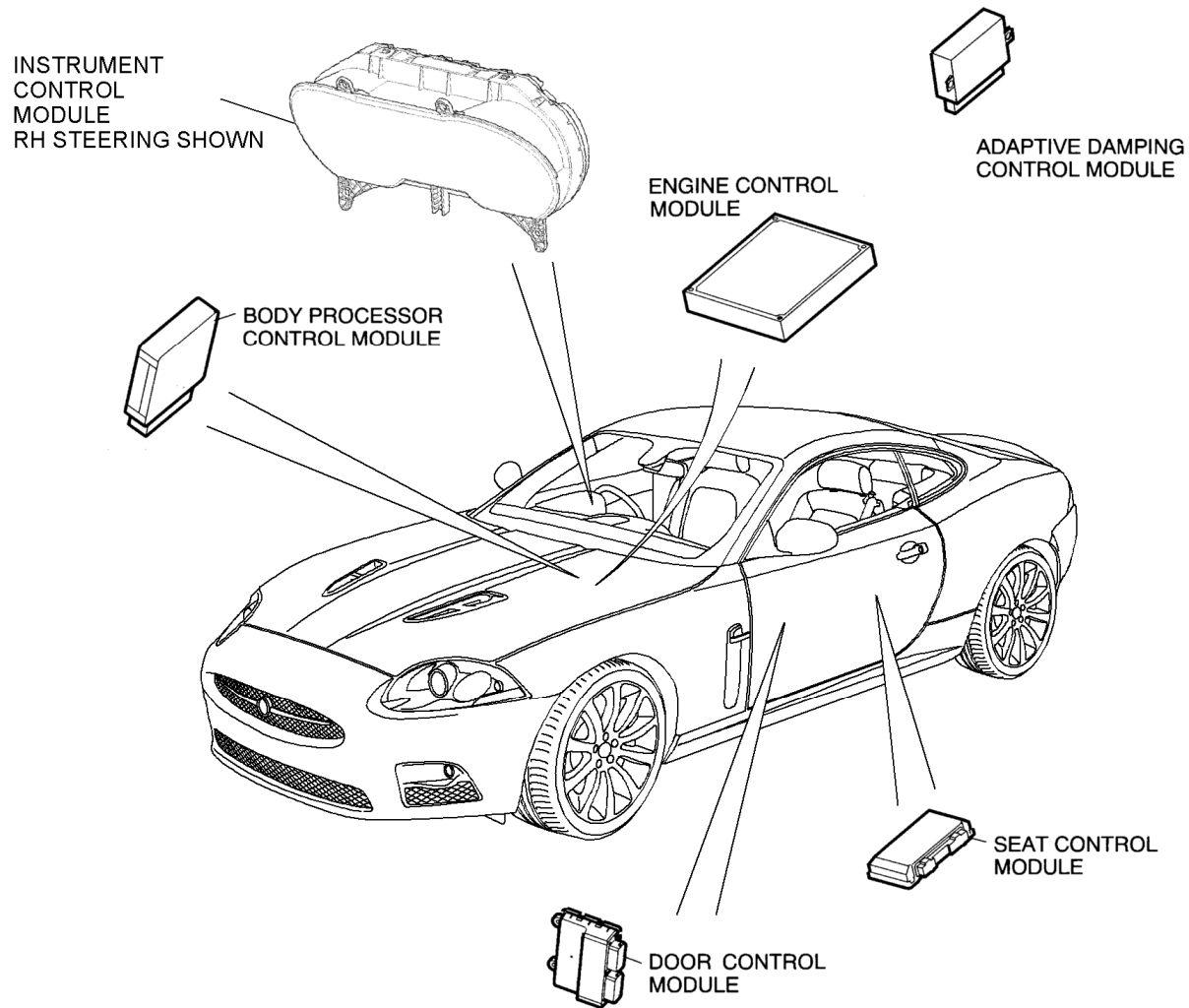

IP1690A

# Body Colour Codes

Colour Name	JBC No	Suffix
Adriatic	1932	JJM
British Racing Green	1753	HGD
Carnival	1811	CGG
Coronada Blue	2020	EDF
Ebony	1807	PEC
Indigo	2003	JJX
Jaguar Racing Green	1957	HGZ
Jupiter Red	2019	JJS
Liquid silver	2029	MEE
Midnight	1959	PEF
Pacific	1905	JHM
Phoenix	1924	CGL

Colour Name	JBC No	Suffix
Platinum	1916	MDZ
Lunar Grey	2028	LJZ
Radiance	1975	CHB
Salsa	1964	CHA
Willow Green	2033	HHM
Slate	1943	LHL
Topaz	1820	JHY
Blue Prism	1947	JJF
Porcelain	2023	NEL
Winter Gold	2002	GDM
Zircon	1927	JHV
Liquid Silver	2029	MEE

# TRIM CODES

---

## Leather

Cashmere	SDZ
Ivory	NED
Warm Charcoal	LEG
Dove	LHJ
Cranberry	CGT
Cranberry Contrast	RFB
Heritage Tan	ADY
Heritage Tan Contrast	RFC

## Carpets

Flint	LFN
Sable	AEK

## Headlining

Oatmeal	AGD
Nimbus	LFJ

## Facia

Sable/Cashmere	AET
Sable/Ivory	AES
Slate/Nimbus	LGG
Warm Charcoal/Ivory	LGJ
Warm Charcoal/Dove	LHM

## Seat Belts

Warm Charcoal	LEG
Sable	AEK

## Hoods

Warm Charcoal	PDM
Sable/Dark Beige	AEV
Blue	JFF
Green	HFV

**X150 COLOUR COMBINATIONS & AVAILABILITY**

Detail Theme	Facia			Seats	Centre console			Door Casing			Upper Environment	Lower Environment	Tonneau (Conv)	Parcel shelf (Coupe)	Carpet	Steering Wheel	Seat Belt	Trunk	Interior		Seats		
	IP Demist	IP Upper	IP Lower		Console	Armrest lid	Door Casing / Rear Quarter Casing upper	(*3) Insert & Armrest/ Rear Quarter Casing lower	(*3) Casing Kick Carpet	Entry Leatherette spec									Option Leather spec	Sports	Lux	R	
1	Warm Charcoal / WARM CHARCOAL	W Char	W Char	W Char	W Char	W Char	W Char	W Char	W Char	Flint	Canvas	W Char	W Char	W Char	Flint	W Char	W Char	Flint / W Char	Y	Y	Y	Y	
2	Slate Blue / IVORY (*4)	W Char	Slate	Slate	Ivory	Slate	Ivory	Slate	Ivory	Ivory	Canvas	Slate	Slate	W Char	Slate	Slate	Slate / W Char (*5)	Flint / W Char	Y	Y	Y	Y	
3	Warm Charcoal / CAMEL	W Char	Caramel	Caramel	Caramel	Caramel	Caramel	Caramel	Caramel	Caramel	Canvas	Caramel	Caramel	W Char	Caramel	Caramel	Caramel	Flint / W Char	Y	Y	Y	Y	
See note (*2) 3 (9)		Colour complexity X150 = 3 (XK = 5)			3 (8)	3 (6)		3 (6)			1 (2)	1 (2)	3 (2)	1 (2)	3 (2)	2 (2)	1 (2)	1 (1)					
"*+1"	Warm Charcoal / IVORY (*4)	W Char	W Char	W Char	Ivory	W Char	Ivory	W Char	Ivory	Ivory	Canvas	W Char	W Char	W Char	Flint	W Char	W Char	Flint / W Char	Y	Y	Y	Y	
See note (*5) 3 (9)		Colour complexity X150 = 3 (XK = 5)			3 (8)	4 (6)		4 (6)			1 (2)	3 (2)	3 (2)	1 (2)	3 (2)	3(2)	3 (2)	1 (1)					

**NOTES**

(\*1) Revisions to this attachment at issue R03 highlighted yellow & BOLD

(\*2) Numbers show X150 complexity (XK 03MY complexity in brackets)

(\*3) "Child" parts - not received in Plant as end items

(\*4) Old Ivory - not New Ivory

(\*5) Slate seat belt webbing with Warm Charcoal belt plastics including buckle cover

**NO CHANGES TO THIS ATTACHMENT AT ISSUE 4**

**X150 MATERIAL MATRIX**

Detail Theme	Facia						Centre console				Door Casing			
	Demist	Upper	Drivers bolster	Glove box	Console front pad	End panels	Armrest / lid front	Armrest / lid rear end cap	Console sides	Console rear panel	Casing top roll and door pocket	Moulding / speaker bezel	Insert Panel & Armrest	Pocket Kick Carpet
<b>Leatherette</b>	L'ette	L'ette	L'ette	L'ette	Moulded	Moulded	Bond Leather	Moulded	L'ette	Moulded	L'ette	Moulding	L'ette	Carpet
<b>Leather</b>	L'ette	Softgrain Leather	<b>Softgrain Leather</b>	<b>Softgrain Leather</b>	Moulded	Moulded	Softgrain Leather	Moulded	<b>Softgrain Leather</b>	Moulded	Softgrain Leather	Moulding	Softgrain Leather	Carpet

Detail Theme	Front seat							Rear seat							
	Seat facings	Seat sides	Squab facings	Squab sides	Back	Map Pocket	Headrest front	Headrest rear	Headrest sides	Seat facings	Squab facings	Squab bolsters	Seat centre cap	Squab centre cap	ISO fix fl
<b>Sports</b>	Bond Leather	Ambla	Bond Leather	Ambla	Ambla	Ambla	Bond Leather	Ambla	Ambla	Bond Leather	Bond Leather	Ambla	Ambla	Ambla	Ambla
<b>Luxury</b>	Softgrain leather	Softgrain leather	Softgrain leather	Softgrain leather	Softgrain leather	Softgrain leather	Softgrain leather	Softgrain leather	Softgrain leather	Softgrain leather	Softgrain leather	Softgrain leather	Softgrain leather	Softgrain leather	Softgrain leather
<b>"R"</b>	Bond Leather	Ambla	Bond Leather	Ambla	Ambla	Ambla	Bond Leather	Ambla	Ambla	Bond Leather	Bond Leather	Ambla	Ambla	Ambla	Ambla

**CHANGES at R04**

**Softgrain Leather confirmed for glovebox, bolsters & console sides (was subject to PACN)**



