

ph7w83-70061-b-ab

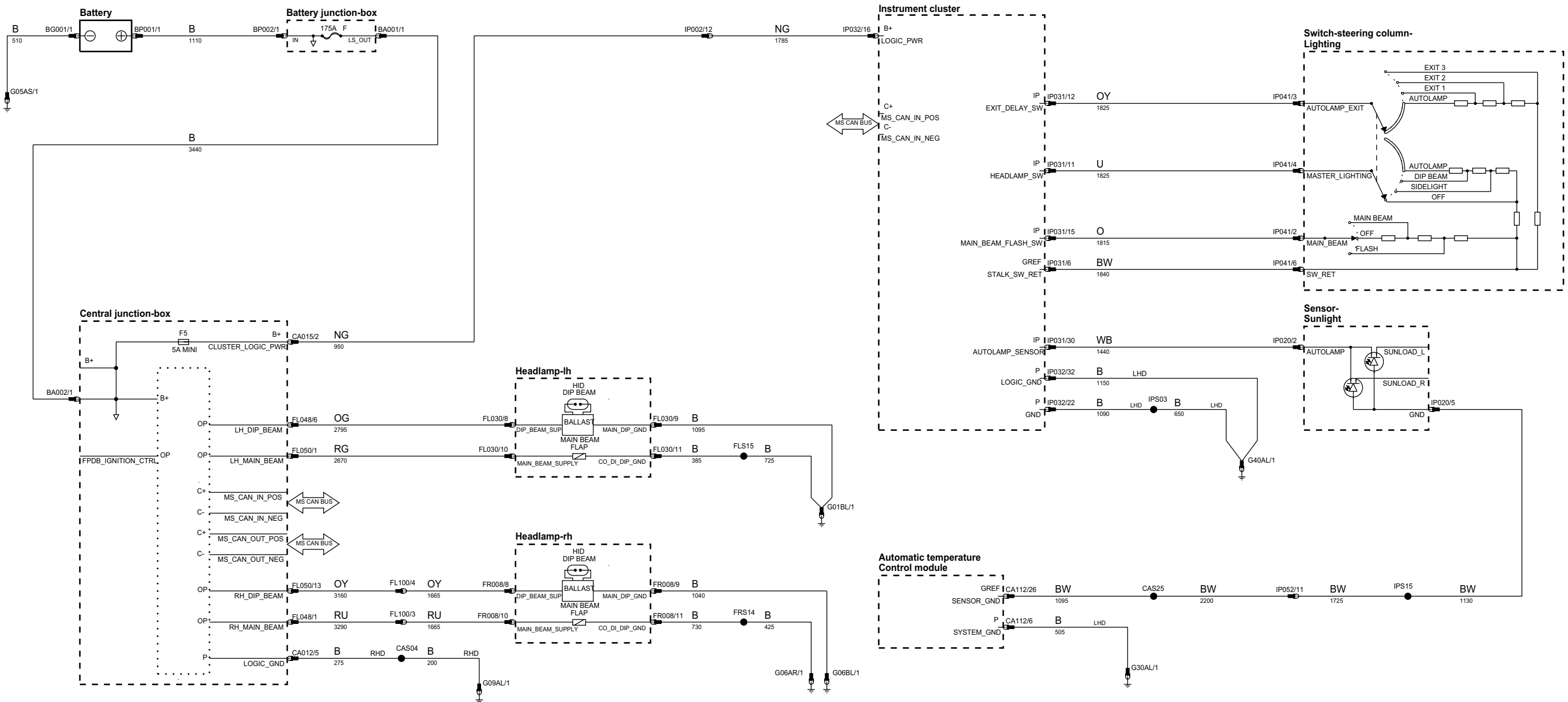

B- Battery Voltage	IP Input	VREF Sensor/Signal Supply V	HS CAN BUS High speed controller area network bus	MOST BUS Media oriented systems transport bus	VARIANT: All
P Power Ground	OP Output	GREF Sensor/Signal Ground	MS CAN BUS Medium speed controller area network bus	D Serial and Encoded Data	VIN RANGE: All
					DATE OF ISSUE: September 2006

ph7w83-70066-e-ab

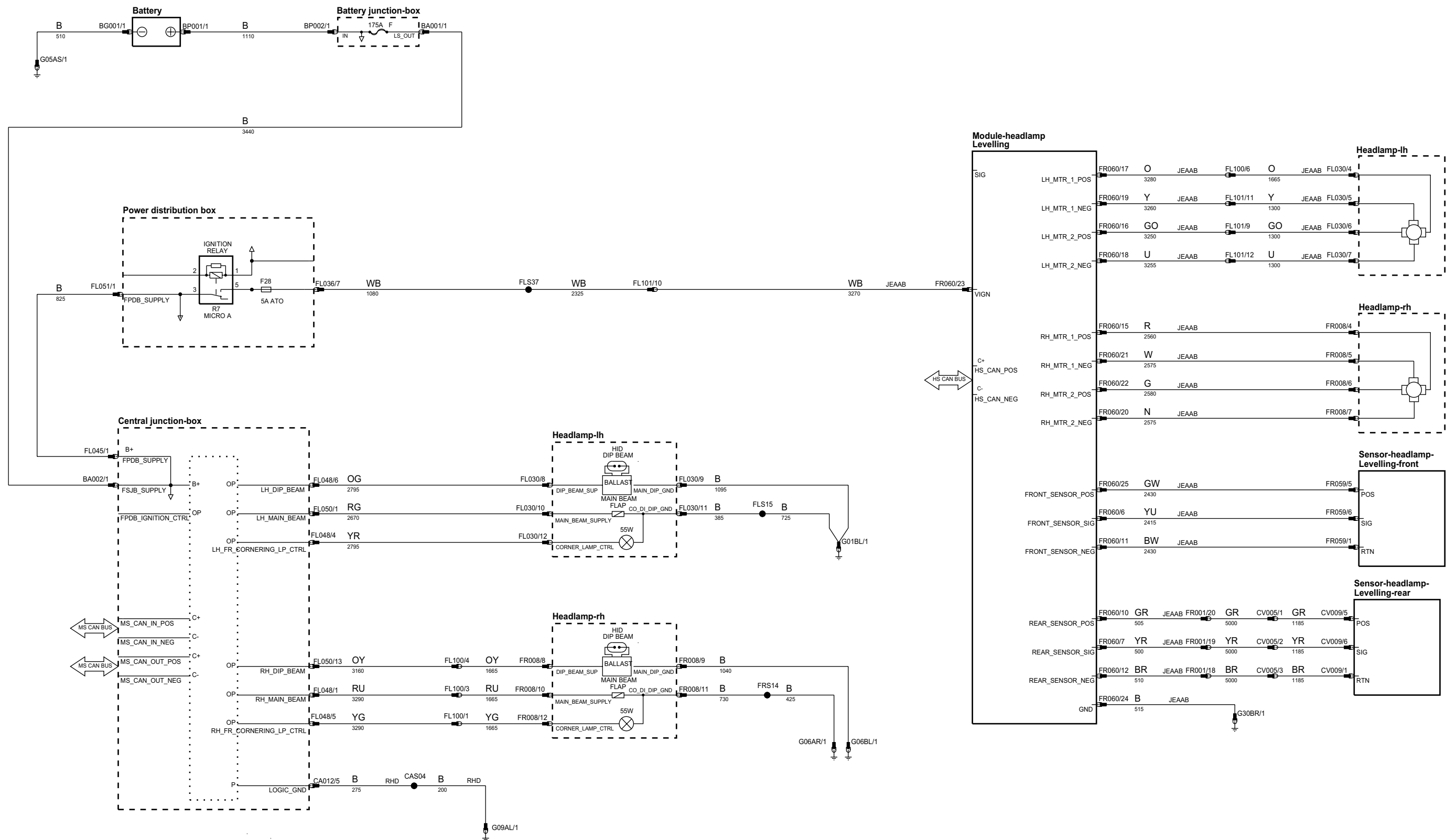

B - Battery Voltage	IP Input	VREF Sensor/Signal Supply V	HS CAN BUS High speed controller area network bus	MOST BUS Media oriented systems transport bus
P Power Ground	OP Output	GRES Sensor/Signal Ground	MS CAN BUS Medium speed controller area network bus	D Serial and Encoded Data

VARIANT: HID Headlamp
VIN RANGE: All
DATE OF ISSUE: September 2006

ph7w83-70066-b-ab

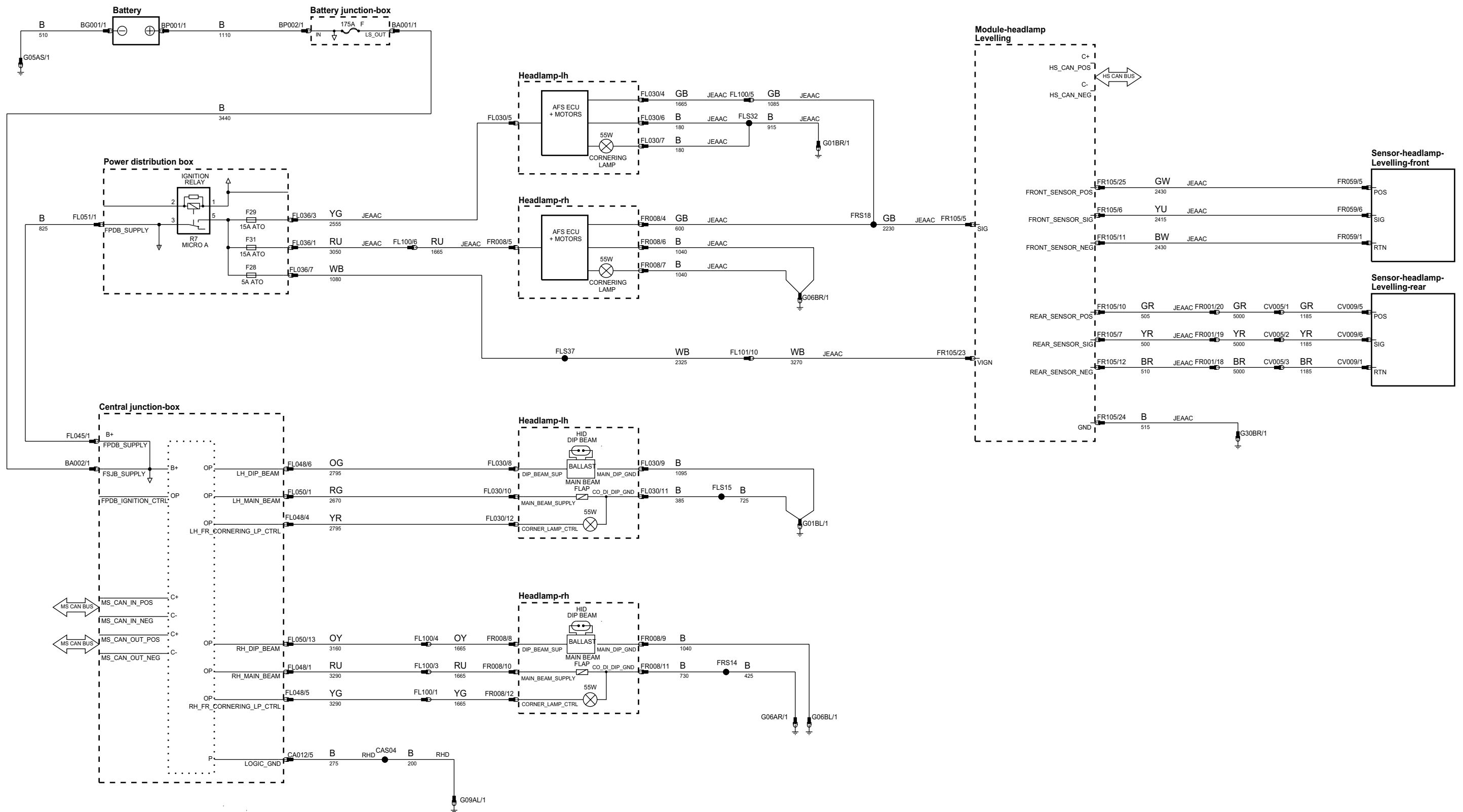

B - Battery Voltage	IP Input	VREF Sensor/Signal Supply V	HS CAN BUS High speed controller area network bus	MOST BUS Media oriented systems transport bus
P Power Ground	OP Output	GRES Sensor/Signal Ground	MS CAN BUS Medium speed controller area network bus	D Serial and Encoded Data

VARIANT: HID Headlamp
VIN RANGE: All
DATE OF ISSUE: September 2006

ph7w83-70060-d-ab

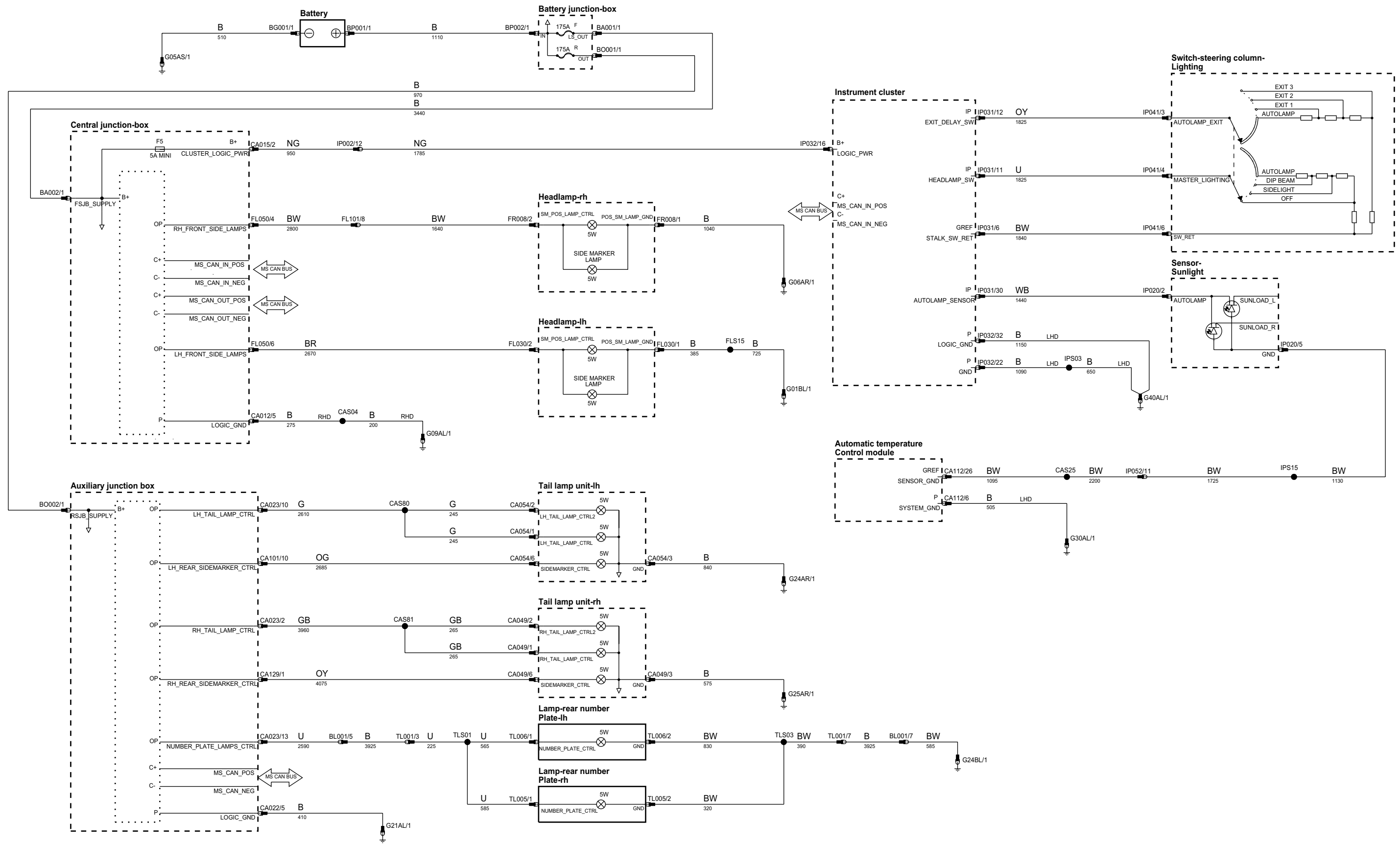

B - Battery Voltage	IP Input	VREF Sensor/Signal Supply V	HS CAN BUS High speed controller area network bus	MOST BUS Media oriented systems transport bus
P Power Ground	OP Output	GRESF Sensor/Signal Ground	MS CAN BUS Medium speed controller area network bus	D Serial and Encoded Data

VARIANT: All
VIN RANGE: All
DATE OF ISSUE: September 2006

ph7w83-70060-c-ab

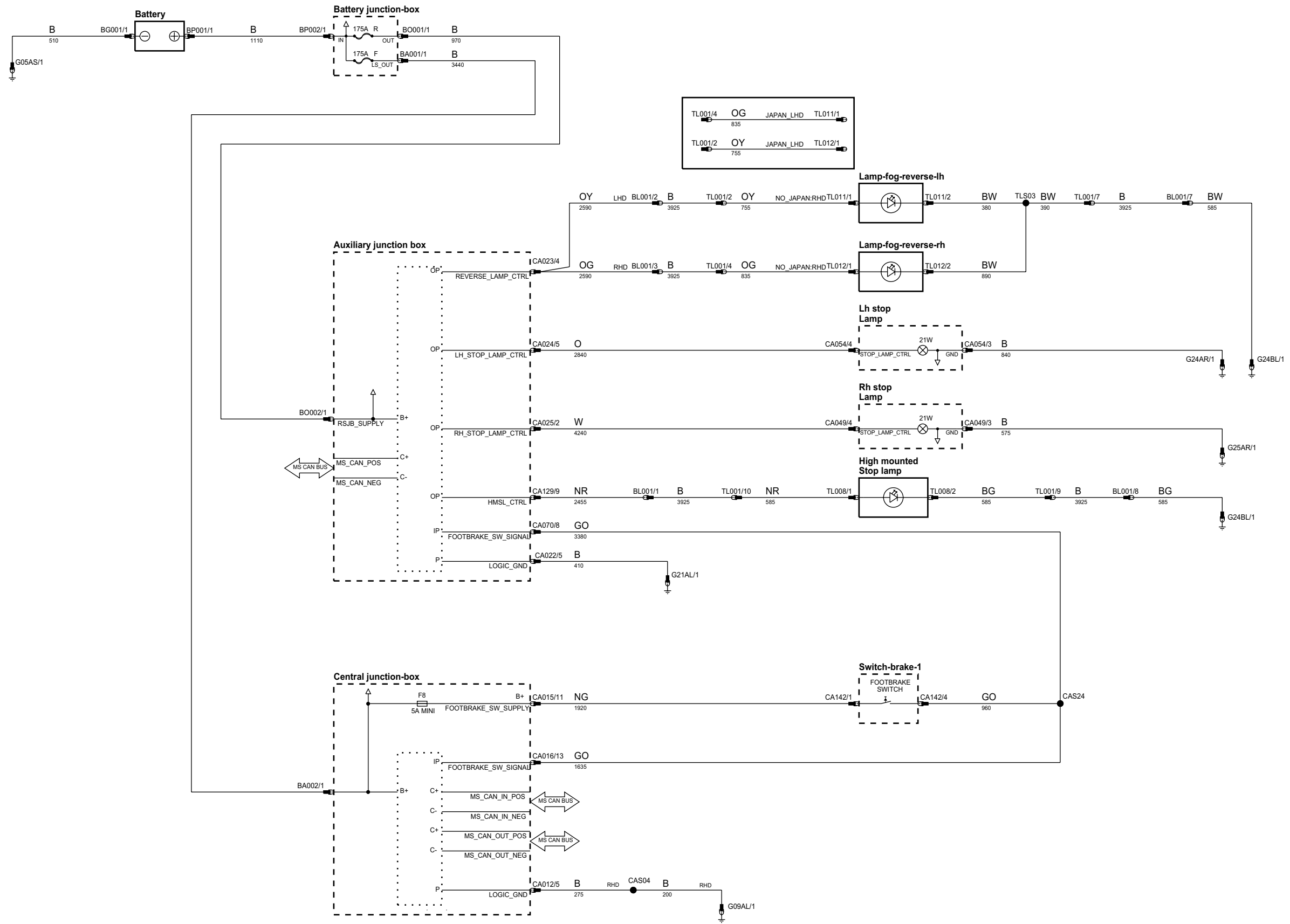

B- Battery Voltage
P Power Ground

IP Input
OP Output

VREF Sensor/Signal Supply V
GREF Sensor/Signal Ground

HS CAN BUS High speed controller area network bus
MS CAN BUS Medium speed controller area network bus

MOST BUS Media oriented systems transport bus
D Serial and Encoded Data

VARIANT: All
VIN RANGE: All
DATE OF ISSUE: September 2006

ph7w83-70080-b-ab

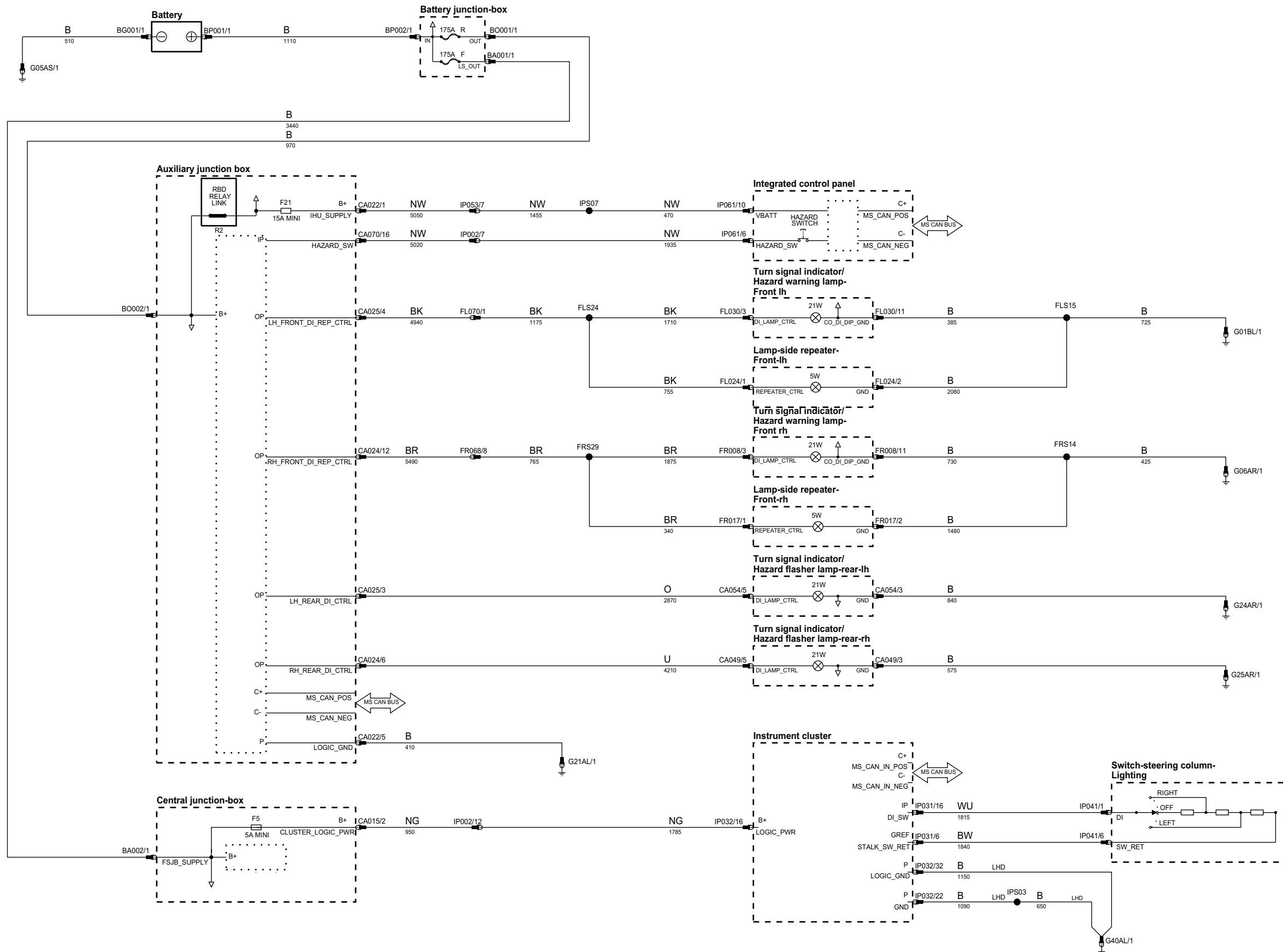

B - Battery Voltage	IP Input	VREF Sensor/Signal Supply V	HS CAN BUS High speed controller area network bus	MOST BUS Media oriented systems transport bus
P Power Ground	OP Output	GRF Sensor/Signal Ground	MS CAN BUS Medium speed controller area network bus	D Serial and Encoded Data

VARIANT: All
 VIN RANGE: All
 DATE OF ISSUE: September 2006

ph7w83-70072-b-ab

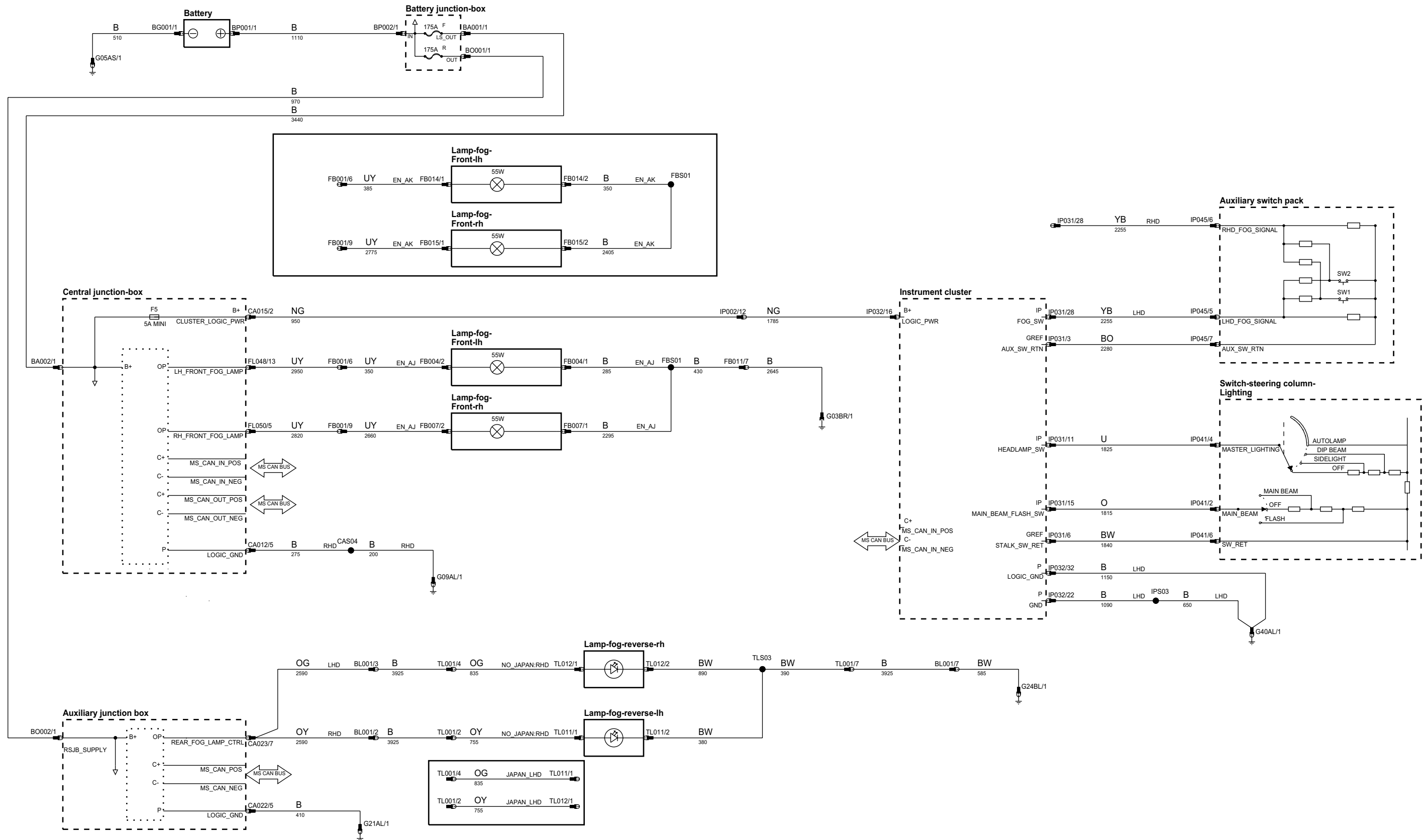

B- Battery Voltage	IP Input	VREF Sensor/Signal Supply V	HS CAN BUS High speed controller area network bus	MOST BUS Media oriented systems transport bus
P Power Ground	OP Output	GREF Sensor/Signal Ground	MS CAN BUS Medium speed controller area network bus	D Serial and Encoded Data

VARIANT: All
 VIN RANGE: All
 DATE OF ISSUE: September 2006