

# Liftgate Alignment (76.19.54.60)

1. Check the gap and profiles of the liftgate are correct.

[Body and Frame](#)

2. Remove the loadspace floor panel.

3. Remove the scuff plate trim panel.

- Remove the 4 Torx bolts.

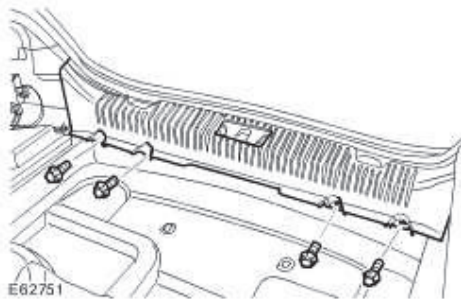

4. Remove the liftgate hinge cover.

- Remove the 8 clips.

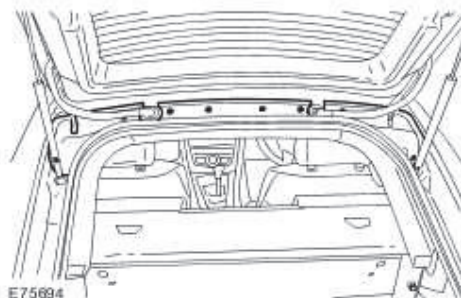

5. Loosen the liftgate striker.

- Loosen the 2 Torx bolts.



6. Loosen the liftgate to hinge Torx bolts.

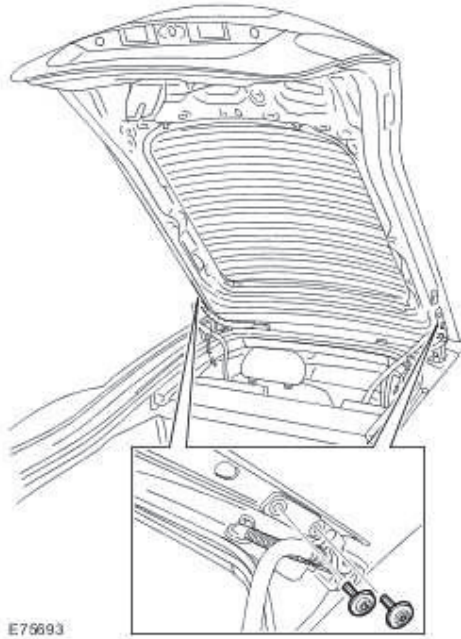

7. With the liftgate closed, check the alignment of the liftgate to the roof panel. Profile of the liftgate to roof panel should be 2 mm below flush.

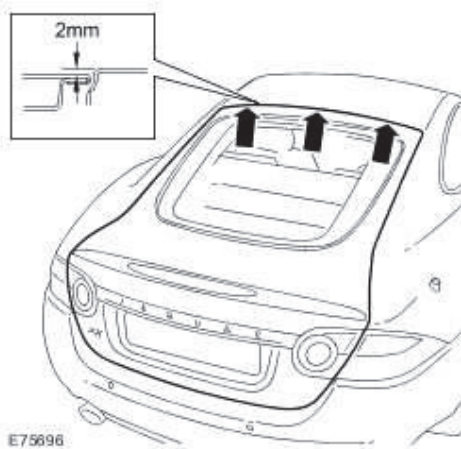

8. Tighten the liftgate to hinge Torx bolts to 25 Nm (18 lb.ft).

9. Loosen the liftgate hinge to body nuts.

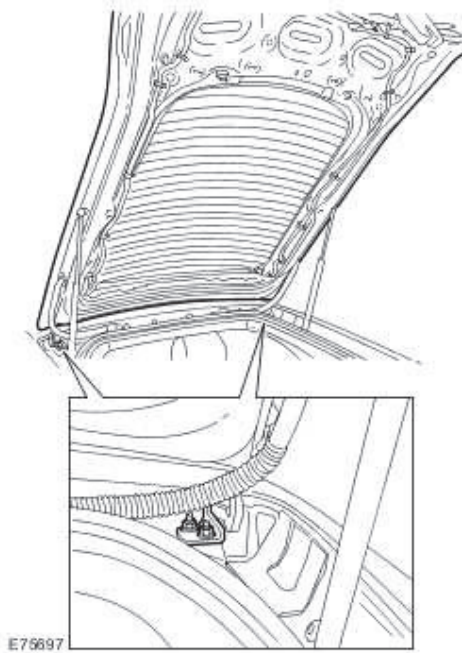

10. With the liftgate closed, check the alignment of the liftgate to the roof panel and bodyside panel. The liftgate should be central in its aperture.

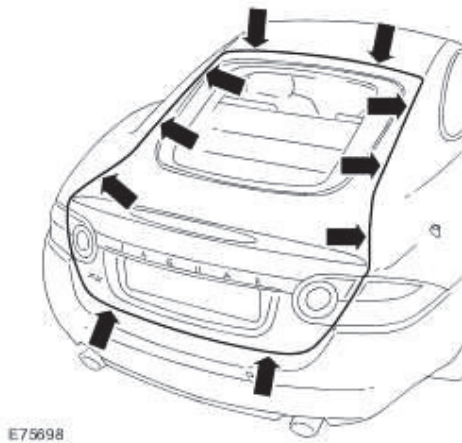

11. Tighten the liftgate hinge to body nuts to 25 Nm (18 lb.ft).

12. Secure the liftgate striker.

- Tighten the Torx bolts to 25 Nm (18 lb.ft).

13. Install the scuff plate trim panel.

- Install the 4 Torx screws

14. With the liftgate closed, check the profile of the liftgate to the bodyside panel. Adjust as

required.

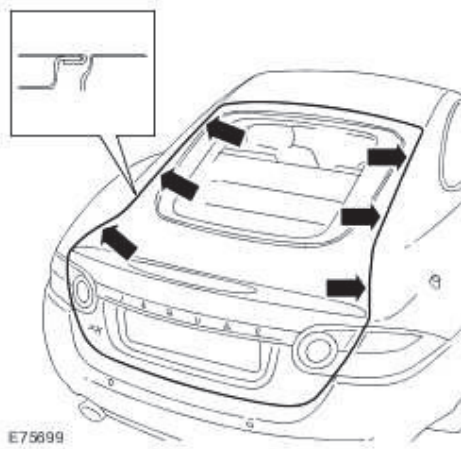

15. Install the liftgate hinge cover.

- Secure with the clips.

16. Install the loadspace floor panel.