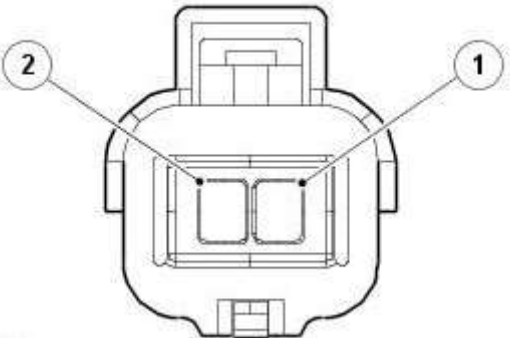

Pinpoint Tests

PINPOINT TEST A : C1D1911 TIRE PRESSURE MONITORING SYSTEM EXTERNAL RECEIVER DATA LINE CIRCUIT SHORT TO GROUND					
TEST CONDITIONS	DETAILS/RESULTS/ACTIONS				
A1: C1D1911 VERIFY EXTERNAL RECEIVER DATA LINE CIRCUIT SHORT TO GROUND					
	<ol style="list-style-type: none"> 1 Ignition off. 2 Disconnect the Tire Pressure Monitoring System Receiver electrical connector, CA131. 3 Measure the resistance between <table border="1" style="width: 100%; border-collapse: collapse;"> <tr> <td style="text-align: center;">CA131, harness side</td> <td style="text-align: center;">Battery</td> </tr> <tr> <td style="text-align: center;">Pin 1</td> <td style="text-align: center;">Negative terminal</td> </tr> </table> <p>Is the resistance less than 5 Ohms? Yes GO to A2. GO to A2. No GO to A3. GO to A3.</p>	CA131, harness side	Battery	Pin 1	Negative terminal
CA131, harness side	Battery				
Pin 1	Negative terminal				
A2: C1D1911 CHECK THE EXTERNAL RECEIVER DATA LINE CIRCUIT FOR SHORT CIRCUIT TO GROUND					
	<ol style="list-style-type: none"> 1 Disconnect the Tire Pressure Monitoring System Control Module electrical connector, CA109. 2 Measure the resistance between <table border="1" style="width: 100%; border-collapse: collapse;"> <tr> <td style="text-align: center;">CA131, harness side</td> <td style="text-align: center;">Battery</td> </tr> <tr> <td style="text-align: center;">Pin 1</td> <td style="text-align: center;">Negative terminal</td> </tr> </table> <p>Is the resistance less than 5 Ohms? Yes REPAIR the short circuit in wiring harness. No GO to A4. GO to A4.</p>	CA131, harness side	Battery	Pin 1	Negative terminal
CA131, harness side	Battery				
Pin 1	Negative terminal				
A3: C1D1911 CHECK THE TIRE PRESSURE MONITORING SYSTEM EXTERNAL RECEIVER FOR SHORT CIRCUIT TO GROUND					
	<ol style="list-style-type: none"> 1 Reconnect the Tire Pressure Monitoring System Receiver electrical connector, CA131. 2 Using manufacturer approved diagnostic system run On Demand Self Test (0x0202). <p>Is the DTC C1D1911 set? Yes Replace Tire Pressure Monitoring Receiver. No Investigate possible cause of intermittent failure.</p>				
A4: C1D1911 CHECK THE TIRE PRESSURE MONITORING SYSTEM CONTROL MODULE FOR SHORT CIRCUIT TO GROUND					
	<ol style="list-style-type: none"> 1 Reconnect the Tire Pressure Monitoring System Control Module electrical connector, CA109. 2 Reconnect the Tire Pressure Monitoring System Receiver electrical connector, CA131. 3 Using manufacturer approved diagnostic system run On Demand Self Test (0x0202). <p>Is the DTC C1D1911 set? Yes Replace Tire Pressure Monitoring System Control Module. No Investigate possible cause of intermittent failure.</p>				

PINPOINT TEST B : LEFT FRONT LOW FREQUENCY INITIATOR CIRCUIT					
TEST CONDITIONS	DETAILS/RESULTS/ACTIONS				
B1: CHECK THE INITIATOR CIRCUIT FOR SHORT CIRCUIT TO GROUND					
	<ol style="list-style-type: none"> 1 Ignition off. 2 Disconnect the left hand front low-frequency initiator electrical connector, FB013. 				
 <p>E63657</p>					
	<ol style="list-style-type: none"> 3 Measure the resistance between: <table border="1" style="width: 100%; border-collapse: collapse;"> <tr> <td style="text-align: center;">FB013, harness side</td> <td style="text-align: center;">Battery</td> </tr> <tr> <td style="text-align: center;">Pin 2</td> <td style="text-align: center;">Negative terminal</td> </tr> </table> <p>Is the resistance less than 10,000 ohms?</p>	FB013, harness side	Battery	Pin 2	Negative terminal
FB013, harness side	Battery				
Pin 2	Negative terminal				

Yes
[GO to B5.](#)
 No
[GO to B2.](#)

B2: CHECK THE INITIATOR CIRCUIT FOR SHORT CIRCUIT TO POWER

1 Measure the resistance between:	
FB013, harness side	Battery
Pin 2	Positive terminal
Is the resistance less than 10,000 ohms?	
Yes GO to B6.	
No GO to B3.	

B3: CHECK THE INITIATOR CIRCUIT FOR SHORT CIRCUIT TO GROUND

1 Measure the resistance between:	
FB013, harness side	Battery
Pin 1	Negative terminal
Is the resistance less than 10,000 ohms?	
Yes GO to B7.	
No GO to B4.	

B4: CHECK THE INITIATOR CIRCUIT FOR SHORT CIRCUIT TO POWER

1 Measure the resistance between:	
FB013, harness side	Battery
Pin 1	Positive terminal
Is the resistance less than 10,000 ohms?	
Yes GO to B8.	
No GO to B9.	

B5: CHECK WHETHER THE SHORT CIRCUIT IS IN THE HARNESS OR THE MODULE

1 Disconnect the Tire Pressure Monitoring System module connector, CA072.

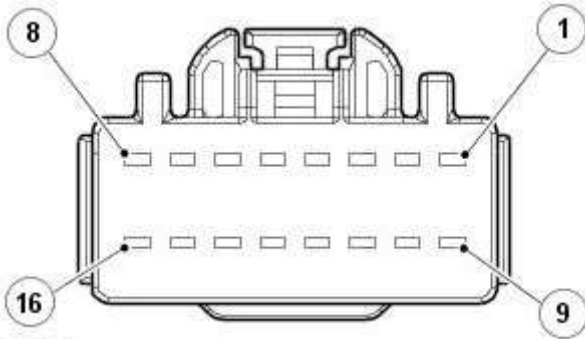

E63655

2 Measure the resistance between:	
FB013, harness side	Battery
Pin 2	Negative terminal
Is the resistance less than 10,000 ohms?	
Yes REPAIR the short circuit. This circuit contains intermediate connectors, FB001 and FLO70. For additional information, refer to the wiring diagram. Clear the DTC and run an On Demand Self Test (ODST) using the manufacturer approved diagnostic system to confirm rectification.	
No INSTALL a new Tire Pressure Monitoring System module. REFER to: (204-04 Wheels and Tires) Tire Pressure Monitoring System (TPMS) Module - Convertible (Removal and Installation), Tire Pressure Monitoring System (TPMS) Module - 2-Door (Removal and Installation).	

B6: CHECK WHETHER THE SHORT CIRCUIT IS IN THE HARNESS OR THE MODULE

1 Disconnect the Tire Pressure Monitoring System module connector, CA072.

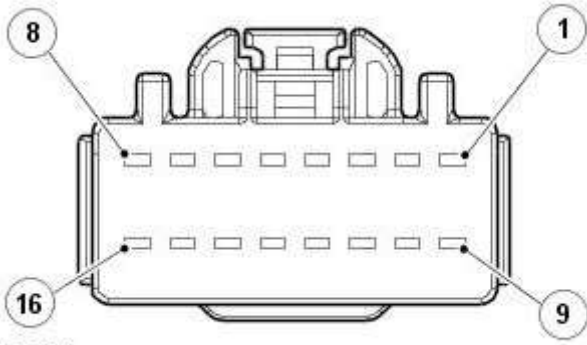

E63655

2 Measure the resistance between:

FB013, harness side	Battery
Pin 2	Positive terminal

Is the resistance less than 10,000 ohms?

Yes
REPAIR the short circuit. This circuit contains intermediate connectors, FB001 and FLO70. For additional information, refer to the wiring diagram. Clear the DTC and run an On Demand Self Test (ODST) using the manufacturer approved diagnostic system to confirm rectification.

No
INSTALL a new Tire Pressure Monitoring System module. REFER to: (204-04 Wheels and Tires)
[Tire Pressure Monitoring System \(TPMS\) Module - Convertible](#) (Removal and Installation),
[Tire Pressure Monitoring System \(TPMS\) Module - 2-Door](#) (Removal and Installation).

B7: CHECK WHETHER THE SHORT CIRCUIT IS IN THE HARNESS OR THE MODULE

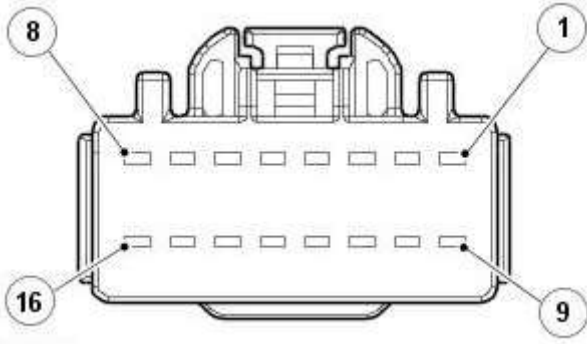

E63655

1 Disconnect the Tire Pressure Monitoring System module connector, CA072.

2 Measure the resistance between:

FB013, harness side	Battery
Pin 1	Negative terminal

Is the resistance less than 10,000 ohms?

Yes
REPAIR the short circuit. This circuit contains intermediate connectors, FB001 and FLO70. For additional information, refer to the wiring diagram. Clear the DTC and run an On Demand Self Test (ODST) using the manufacturer approved diagnostic system to confirm rectification.

No
INSTALL a new Tire Pressure Monitoring System module. REFER to: (204-04 Wheels and Tires)
[Tire Pressure Monitoring System \(TPMS\) Module - Convertible](#) (Removal and Installation),
[Tire Pressure Monitoring System \(TPMS\) Module - 2-Door](#) (Removal and Installation).

B8: CHECK WHETHER THE SHORT CIRCUIT IS IN THE HARNESS OR THE MODULE

1 Disconnect the Tire Pressure Monitoring System module connector, CA072.

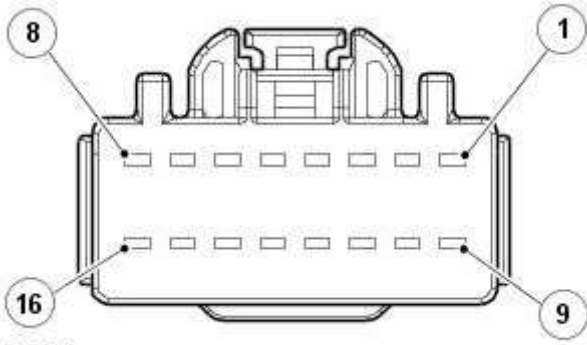

E63655

2 Measure the resistance between:	
FB013, harness side	Battery
Pin 1	Positive terminal
Is the resistance less than 10,000 ohms?	
Yes	
REPAIR the short circuit. This circuit contains intermediate connectors, FB001 and FLO70. For additional information, refer to the wiring diagram. Clear the DTC and run an On Demand Self Test (ODST) using the manufacturer approved diagnostic system to confirm rectification.	
No	
INSTALL a new Tire Pressure Monitoring System module. REFER to: (204-04 Wheels and Tires)	
REFER to: Tire Pressure Monitoring System (TPMS) Module - Convertible (Removal and Installation), Tire Pressure Monitoring System (TPMS) Module - 2-Door (Removal and Installation).	

B9: CHECK THE INITIATOR CIRCUIT FOR HIGH RESISTANCE

1 Measure the resistance between:	
CA072, harness side	FB013, harness side
Pin 14	Pin 2
Is the resistance greater than 5 ohms?	
Yes	
REPAIR the high resistance circuit. This circuit contains intermediate connectors, FB001 and FLO70. For additional information, refer to the wiring diagram. Clear the DTC and run an On Demand Self Test (ODST) using the manufacturer approved diagnostic system to confirm rectification.	
No	
GO to B10.	

B10: CHECK THE INITIATOR CIRCUIT FOR HIGH RESISTANCE

1 Measure the resistance between:	
CA072, harness side	FB013, harness side
Pin 13	Pin 1
Is the resistance greater than 5 ohms?	
Yes	
REPAIR the high resistance circuit. This circuit contains intermediate connectors, FB001 and FLO70. For additional information, refer to the wiring diagram. Clear the DTC and run an On Demand Self Test (ODST) using the manufacturer approved diagnostic system to confirm rectification.	
No	
INSTALL a new left hand front low-frequency initiator. REFER to: Tire Pressure Monitoring System (TPMS) Front Antenna (204-04 Wheels and Tires, Removal and Installation).	

PINPOINT TEST C : RIGHT FRONT LOW FREQUENCY INITIATOR CIRCUIT

TEST CONDITIONS	DETAILS/RESULTS/ACTIONS
C1: CHECK THE INITIATOR CIRCUIT FOR SHORT CIRCUIT TO GROUND	
1	Ignition off.
2	Disconnect the right hand front low-frequency initiator

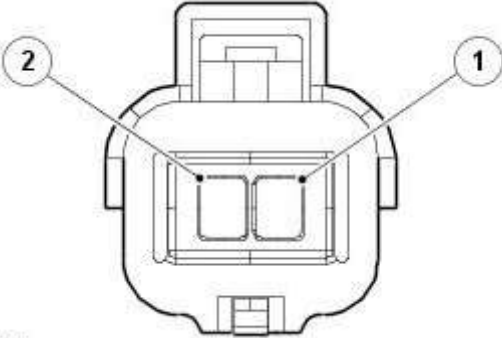
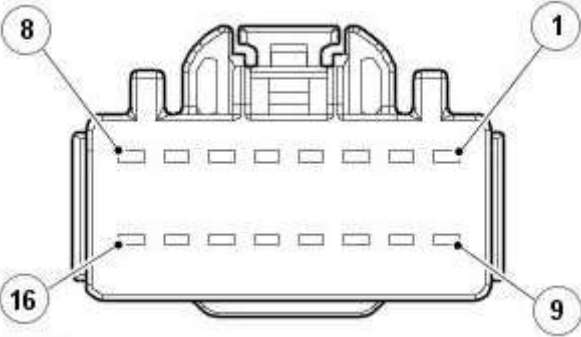
 <p>E63657</p>	<p>electrical connector, FB012.</p> <p>3 Measure the resistance between:</p> <table border="1" data-bbox="764 208 1439 271"> <thead> <tr> <th>FB012, harness side</th> <th>Battery</th> </tr> </thead> <tbody> <tr> <td>Pin 2</td> <td>Negative terminal</td> </tr> </tbody> </table>	FB012, harness side	Battery	Pin 2	Negative terminal
FB012, harness side	Battery				
Pin 2	Negative terminal				
	<p>Is the resistance less than 10,000 ohms? Yes GO to C5. No GO to C2.</p>				
<p>C2: CHECK THE INITIATOR CIRCUIT FOR SHORT CIRCUIT TO POWER</p>					
	<p>1 Measure the resistance between:</p> <table border="1" data-bbox="764 757 1439 819"> <thead> <tr> <th>FB012, harness side</th> <th>Battery</th> </tr> </thead> <tbody> <tr> <td>Pin 2</td> <td>Positive terminal</td> </tr> </tbody> </table> <p>Is the resistance less than 10,000 ohms? Yes GO to C6. No GO to C3.</p>	FB012, harness side	Battery	Pin 2	Positive terminal
FB012, harness side	Battery				
Pin 2	Positive terminal				
<p>C3: CHECK THE INITIATOR CIRCUIT FOR SHORT CIRCUIT TO GROUND</p>					
	<p>1 Measure the resistance between:</p> <table border="1" data-bbox="764 1019 1439 1081"> <thead> <tr> <th>FB012, harness side</th> <th>Battery</th> </tr> </thead> <tbody> <tr> <td>Pin 1</td> <td>Negative terminal</td> </tr> </tbody> </table> <p>Is the resistance less than 10,000 ohms? Yes GO to C7. No GO to C4.</p>	FB012, harness side	Battery	Pin 1	Negative terminal
FB012, harness side	Battery				
Pin 1	Negative terminal				
<p>C4: CHECK THE INITIATOR CIRCUIT FOR SHORT CIRCUIT TO POWER</p>					
	<p>1 Measure the resistance between:</p> <table border="1" data-bbox="764 1281 1439 1344"> <thead> <tr> <th>FB012, harness side</th> <th>Battery</th> </tr> </thead> <tbody> <tr> <td>Pin 1</td> <td>Positive terminal</td> </tr> </tbody> </table> <p>Is the resistance less than 10,000 ohms? Yes GO to C8. No GO to C9.</p>	FB012, harness side	Battery	Pin 1	Positive terminal
FB012, harness side	Battery				
Pin 1	Positive terminal				
<p>C5: CHECK WHETHER THE SHORT CIRCUIT IS IN THE HARNESS OR THE MODULE</p>					
 <p>E63655</p>	<p>1 Disconnect the Tire Pressure Monitoring System module connector, CA072.</p> <p>2 Measure the resistance between:</p> <table border="1" data-bbox="764 1592 1439 1655"> <thead> <tr> <th>FB012, harness side</th> <th>Battery</th> </tr> </thead> <tbody> <tr> <td>Pin 2</td> <td>Negative terminal</td> </tr> </tbody> </table>	FB012, harness side	Battery	Pin 2	Negative terminal
FB012, harness side	Battery				
Pin 2	Negative terminal				
	<p>Is the resistance less than 10,000 ohms? Yes REPAIR the short circuit. This circuit contains intermediate connectors, FB001 and FL070. For additional information, refer to the wiring diagram. Clear the DTC</p>				

and run an On Demand Self Test (ODST) using the manufacturer approved diagnostic system to confirm rectification.

No

INSTALL a new Tire Pressure Monitoring System module. REFER to: (204-04 Wheels and Tires)

[Tire Pressure Monitoring System \(TPMS\) Module - Convertible](#) (Removal and Installation),
[Tire Pressure Monitoring System \(TPMS\) Module - 2-Door](#) (Removal and Installation).

C6: CHECK WHETHER THE SHORT CIRCUIT IS IN THE HARNESS OR THE MODULE

1 Disconnect the Tire Pressure Monitoring System module connector, CA072.

2 Measure the resistance between:

FB012, harness side	Battery
Pin 2	Positive terminal

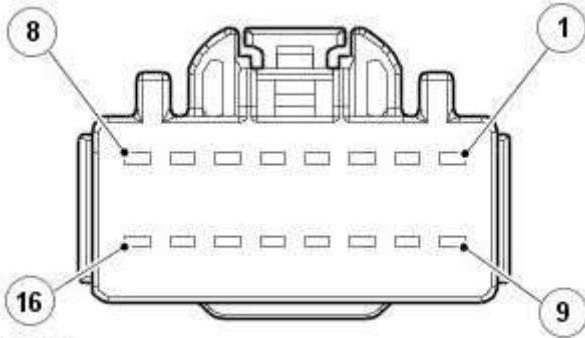

E63655

Is the resistance less than 10,000 ohms?

Yes

REPAIR the short circuit. This circuit contains intermediate connectors, FB001 and FLO70. For additional information, refer to the wiring diagram. Clear the DTC and run an On Demand Self Test (ODST) using the manufacturer approved diagnostic system to confirm rectification.

No

INSTALL a new Tire Pressure Monitoring System module. REFER to: (204-04 Wheels and Tires)

[Tire Pressure Monitoring System \(TPMS\) Module - Convertible](#) (Removal and Installation),
[Tire Pressure Monitoring System \(TPMS\) Module - 2-Door](#) (Removal and Installation).

C7: CHECK WHETHER THE SHORT CIRCUIT IS IN THE HARNESS OR THE MODULE

1 Disconnect the Tire Pressure Monitoring System module connector, FB072.

2 Measure the resistance between:

FB012, harness side	Battery
Pin 1	Negative terminal

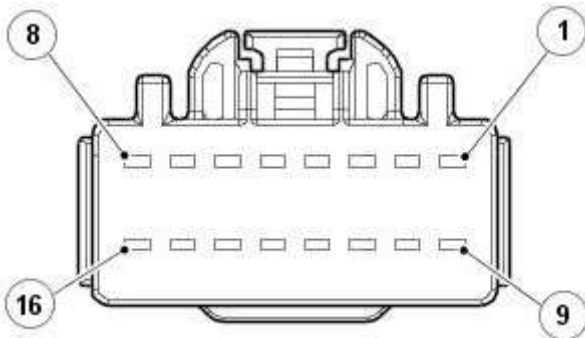

E63655

Is the resistance less than 10,000 ohms?

Yes

REPAIR the short circuit. This circuit contains intermediate connectors, FB001 and FLO70. For additional information, refer to the wiring diagram. Clear the DTC and run an On Demand Self Test (ODST) using the manufacturer approved diagnostic system to confirm rectification.

No

INSTALL a new Tire Pressure Monitoring System module. REFER to: (204-04 Wheels and Tires)

[Tire Pressure Monitoring System \(TPMS\) Module - Convertible](#) (Removal and Installation),

C8: CHECK WHETHER THE SHORT CIRCUIT IS IN THE HARNESS OR THE MODULE

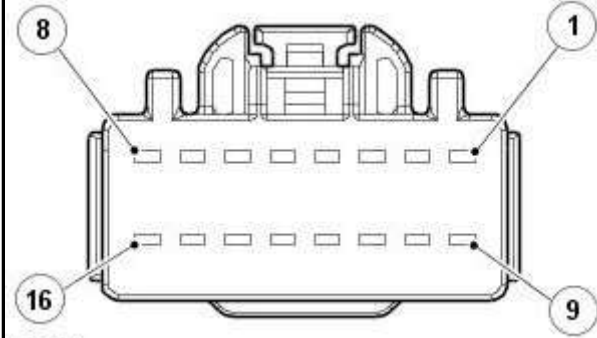

E63655

1 Disconnect the Tire Pressure Monitoring System module connector, CA072.

2 Measure the resistance between:

FB012, harness side	Battery
Pin 1	Positive terminal

Is the resistance less than 10,000 ohms?

Yes

REPAIR the short circuit. This circuit contains intermediate connectors, FB001 and FLO70. For additional information, refer to the wiring diagram. Clear the DTC and run an On Demand Self Test (ODST) using the manufacturer approved diagnostic system to confirm rectification.

No

INSTALL a new Tire Pressure Monitoring System module. REFER to: (204-04 Wheels and Tires)

[Tire Pressure Monitoring System \(TPMS\) Module - Convertible](#) (Removal and Installation),
[Tire Pressure Monitoring System \(TPMS\) Module - 2-Door](#) (Removal and Installation).

C9: CHECK THE INITIATOR CIRCUIT FOR HIGH RESISTANCE

1 Measure the resistance between:

CA072, harness side	FB012, harness side
Pin 16	Pin 2

Is the resistance greater than 5 ohms?

Yes

REPAIR the high resistance circuit. This circuit contains intermediate connectors, FB001 and FLO70. For additional information, refer to the wiring diagram. Clear the DTC and run an On Demand Self Test (ODST) using the manufacturer approved diagnostic system to confirm rectification.

No

[GO to C10.](#)

C10: CHECK THE INITIATOR CIRCUIT FOR HIGH RESISTANCE

1 Measure the resistance between:

CA072, harness side	FB012, harness side
Pin 15	Pin 1

Is the resistance greater than 5 ohms?

Yes

REPAIR the high resistance circuit. This circuit contains intermediate connectors, FB001 and FLO70. For additional information, refer to the wiring diagram. Clear the DTC and run an On Demand Self Test (ODST) using the manufacturer approved diagnostic system to confirm rectification.

No

INSTALL a new right hand front low-frequency initiator. REFER to: [Tire Pressure Monitoring System \(TPMS\) Front Antenna](#) (204-04 Wheels and Tires, Removal and Installation).

PINPOINT TEST D : LEFT REAR LOW FREQUENCY INITIATOR CIRCUIT

TEST CONDITIONS	DETAILS/RESULTS/ACTIONS
D1: CHECK THE INITIATOR CIRCUIT FOR SHORT CIRCUIT TO GROUND	
	1 Ignition off.

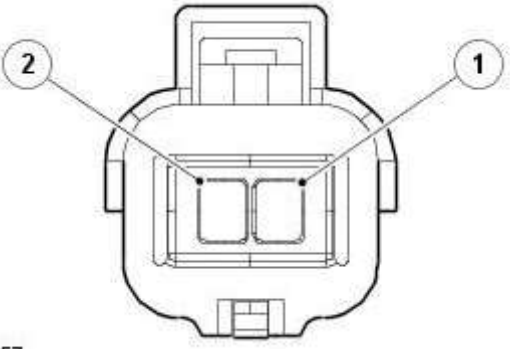
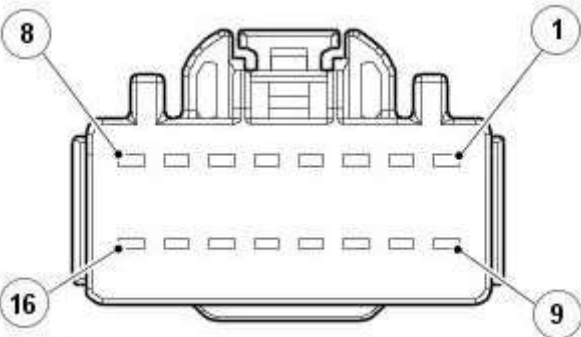
 <p>E63657</p>	<p>2 Disconnect the left hand rear low-frequency initiator electrical connector, RB010.</p> <p>3 Measure the resistance between:</p> <table border="1" data-bbox="767 235 1441 295"> <thead> <tr> <th>RB010, harness side</th> <th>Battery</th> </tr> </thead> <tbody> <tr> <td>Pin 2</td> <td>Negative terminal</td> </tr> </tbody> </table>	RB010, harness side	Battery	Pin 2	Negative terminal
RB010, harness side	Battery				
Pin 2	Negative terminal				
	<p>Is the resistance less than 10,000 ohms? Yes GO to D5. No GO to D2.</p>				
<p>D2: CHECK THE INITIATOR CIRCUIT FOR SHORT CIRCUIT TO POWER</p>					
	<p>1 Measure the resistance between:</p> <table border="1" data-bbox="767 784 1441 844"> <thead> <tr> <th>RB010, harness side</th> <th>Battery</th> </tr> </thead> <tbody> <tr> <td>Pin 2</td> <td>Positive terminal</td> </tr> </tbody> </table> <p>Is the resistance less than 10,000 ohms? Yes GO to D6. No GO to D3.</p>	RB010, harness side	Battery	Pin 2	Positive terminal
RB010, harness side	Battery				
Pin 2	Positive terminal				
<p>D3: CHECK THE INITIATOR CIRCUIT FOR SHORT CIRCUIT TO GROUND</p>					
	<p>1 Measure the resistance between:</p> <table border="1" data-bbox="767 1041 1441 1102"> <thead> <tr> <th>RB010, harness side</th> <th>Battery</th> </tr> </thead> <tbody> <tr> <td>Pin 1</td> <td>Negative terminal</td> </tr> </tbody> </table> <p>Is the resistance less than 10,000 ohms? Yes GO to D7. No GO to D4.</p>	RB010, harness side	Battery	Pin 1	Negative terminal
RB010, harness side	Battery				
Pin 1	Negative terminal				
<p>D4: CHECK THE INITIATOR CIRCUIT FOR SHORT CIRCUIT TO POWER</p>					
	<p>1 Measure the resistance between:</p> <table border="1" data-bbox="767 1299 1441 1359"> <thead> <tr> <th>RB010, harness side</th> <th>Battery</th> </tr> </thead> <tbody> <tr> <td>Pin 1</td> <td>Positive terminal</td> </tr> </tbody> </table> <p>Is the resistance less than 10,000 ohms? Yes GO to D8. No GO to D9.</p>	RB010, harness side	Battery	Pin 1	Positive terminal
RB010, harness side	Battery				
Pin 1	Positive terminal				
<p>D5: CHECK WHETHER THE SHORT CIRCUIT IS IN THE HARNESS OR THE MODULE</p>					
 <p>E63655</p>	<p>1 Disconnect the Tire Pressure Monitoring System module connector, CA072.</p> <p>2 Measure the resistance between:</p> <table border="1" data-bbox="767 1612 1441 1673"> <thead> <tr> <th>RB010, harness side</th> <th>Battery</th> </tr> </thead> <tbody> <tr> <td>Pin 2</td> <td>Negative terminal</td> </tr> </tbody> </table>	RB010, harness side	Battery	Pin 2	Negative terminal
RB010, harness side	Battery				
Pin 2	Negative terminal				
	<p>Is the resistance less than 10,000 ohms? Yes REPAIR the short circuit. This circuit contains intermediate connector, RBO01. For additional</p>				

information, refer to the wiring diagram. Clear the DTC and run an On Demand Self Test (ODST) using the manufacturer approved diagnostic system to confirm rectification.

No

INSTALL a new Tire Pressure Monitoring System module. REFER to: (204-04 Wheels and Tires)

[Tire Pressure Monitoring System \(TPMS\) Module - Convertible](#) (Removal and Installation),

[Tire Pressure Monitoring System \(TPMS\) Module - 2-Door](#) (Removal and Installation).

D6: CHECK WHETHER THE SHORT CIRCUIT IS IN THE HARNESS OR THE MODULE

1 Disconnect the Tire Pressure Monitoring System module connector, CA072.

2 Measure the resistance between:

RB010, harness side	Battery
Pin 2	Positive terminal

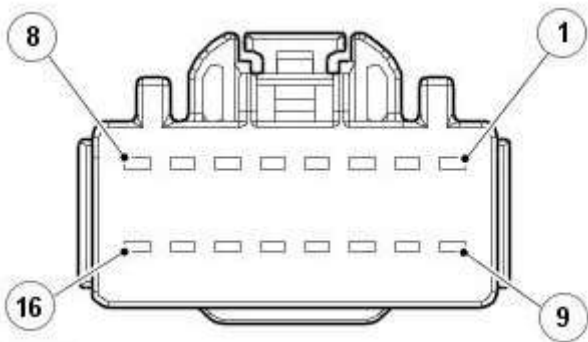

E63655

Is the resistance less than 10,000 ohms?

Yes

REPAIR the short circuit. This circuit contains intermediate connector, RB001. For additional information, refer to the wiring diagram. Clear the DTC and run an On Demand Self Test (ODST) using the manufacturer approved diagnostic system to confirm rectification.

No

INSTALL a new Tire Pressure Monitoring System module. REFER to: (204-04 Wheels and Tires)

[Tire Pressure Monitoring System \(TPMS\) Module - Convertible](#) (Removal and Installation),

[Tire Pressure Monitoring System \(TPMS\) Module - 2-Door](#) (Removal and Installation).

D7: CHECK WHETHER THE SHORT CIRCUIT IS IN THE HARNESS OR THE MODULE

1 Disconnect the Tire Pressure Monitoring System module connector, CA072.

2 Measure the resistance between:

RB010, harness side	Battery
Pin 1	Negative terminal

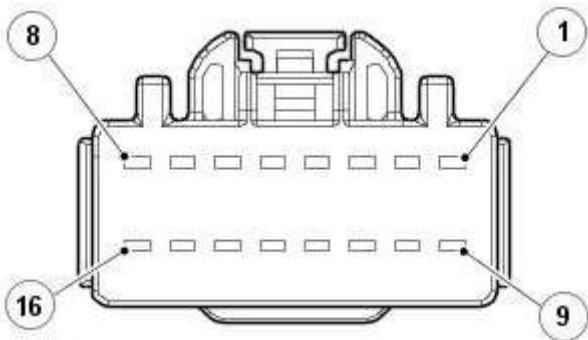

E63655

Is the resistance less than 10,000 ohms?

Yes

REPAIR the short circuit. This circuit contains intermediate connector, RB001. For additional information, refer to the wiring diagram. Clear the DTC and run an On Demand Self Test (ODST) using the manufacturer approved diagnostic system to confirm rectification.

No

INSTALL a new Tire Pressure Monitoring System module. REFER to: (204-04 Wheels and Tires)

[Tire Pressure Monitoring System \(TPMS\) Module -](#)

[Convertible](#) (Removal and Installation),
[Tire Pressure Monitoring System \(TPMS\) Module - 2-Door](#) (Removal and Installation).

D8: CHECK WHETHER THE SHORT CIRCUIT IS IN THE HARNESS OR THE MODULE

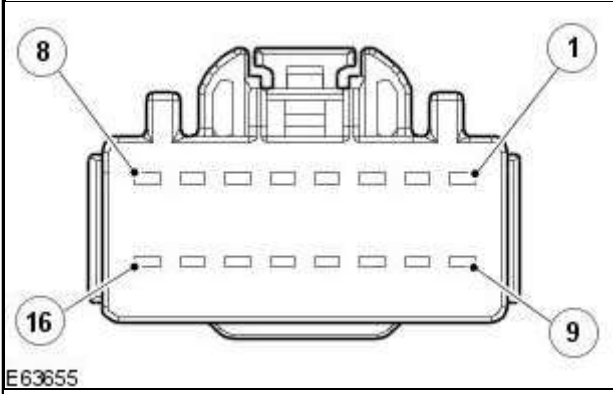

E63655

1 Disconnect the Tire Pressure Monitoring System module connector, CA072.

2 Measure the resistance between:

RB010, harness side	Battery
Pin 1	Positive terminal

Is the resistance less than 10,000 ohms?
Yes
 REPAIR the short circuit. This circuit contains intermediate connector, RB001. For additional information, refer to the wiring diagram. Clear the DTC and run an On Demand Self Test (ODST) using the manufacturer approved diagnostic system to confirm rectification.
No
 INSTALL a new Tire Pressure Monitoring System module. REFER to: (204-04 Wheels and Tires) [Tire Pressure Monitoring System \(TPMS\) Module - Convertible](#) (Removal and Installation), [Tire Pressure Monitoring System \(TPMS\) Module - 2-Door](#) (Removal and Installation).

D9: CHECK THE INITIATOR RETURN CIRCUIT FOR HIGH RESISTANCE

1 Measure the resistance between:

CA072, harness side	RB010, harness side
Pin 6	Pin 2

Is the resistance greater than 5 ohms?
Yes
 REPAIR the high resistance circuit. This circuit contains intermediate connector, RB001. For additional information, refer to the wiring diagram. Clear the DTC and run an On Demand Self Test (ODST) using the manufacturer approved diagnostic system to confirm rectification.
No
[GO to E1.](#)

D10: CHECK THE INITIATOR CIRCUIT FOR HIGH RESISTANCE

1 Measure the resistance between:

CA072, harness side	RB010, harness side
Pin 5	Pin 1

Is the resistance greater than 5 ohms?
Yes
 REPAIR the high resistance circuit. This circuit contains intermediate connector, RB001. For additional information, refer to the wiring diagram. Clear the DTC and run an On Demand Self Test (ODST) using the manufacturer approved diagnostic system to confirm rectification.
No
 INSTALL a new rear left hand low-frequency initiator. REFER to: [Tire Pressure Monitoring System \(TPMS\) Rear Antenna](#) (204-04 Wheels and Tires, Removal and Installation).

PINPOINT TEST E : RIGHT REAR LOW FREQUENCY INITIATOR CIRCUIT

TEST CONDITIONS	DETAILS/RESULTS/ACTIONS
E1: CHECK THE INITIATOR CIRCUIT FOR SHORT CIRCUIT TO GROUND	

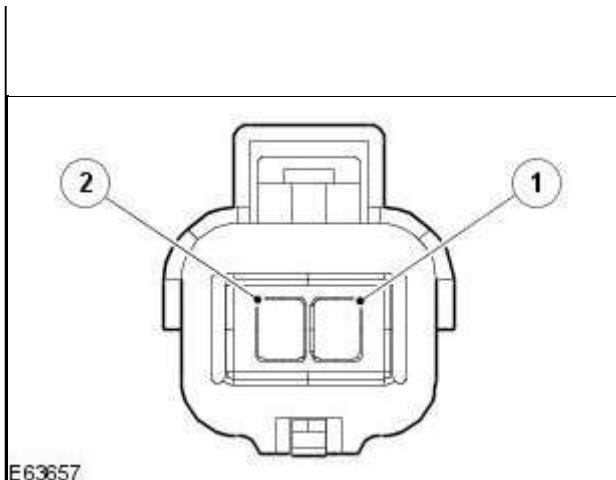

E63657

- 1** Ignition off.
- 2** Disconnect the right hand rear low-frequency initiator electrical connector, RB009.

3 Measure the resistance between:

RB009, harness side	Battery
Pin 2	Negative terminal

Is the resistance less than 10,000 ohms?
Yes
[GO to E5.](#)
No
[GO to E2.](#)

E2: CHECK THE INITIATOR CIRCUIT FOR SHORT CIRCUIT TO POWER

1 Measure the resistance between:

RB009, harness side	Battery
Pin 2	Positive terminal

Is the resistance less than 10,000 ohms?
Yes
[GO to E6.](#)
No
[GO to E3.](#)

E3: CHECK THE INITIATOR CIRCUIT FOR SHORT CIRCUIT TO GROUND

1 Measure the resistance between:

RB009, harness side	Battery
Pin 1	Negative terminal

Is the resistance less than 10,000 ohms?
Yes
[GO to E7.](#)
No
[GO to E4.](#)

E4: CHECK THE INITIATOR CIRCUIT FOR SHORT CIRCUIT TO POWER

1 Measure the resistance between:

RB009, harness side	Battery
Pin 1	Positive terminal

Is the resistance less than 10,000 ohms?
Yes
[GO to E8.](#)
No
[GO to E9.](#)

E5: CHECK WHETHER THE SHORT CIRCUIT IS IN THE HARNESS OR THE MODULE

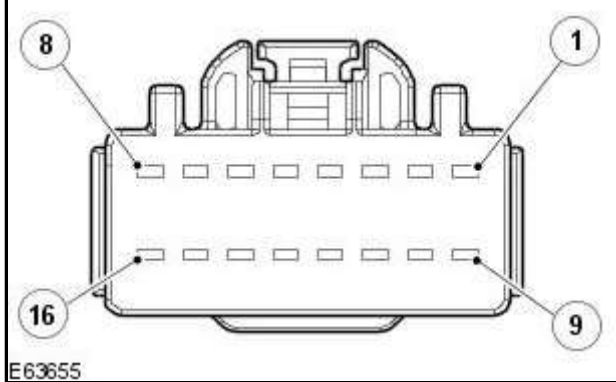

E63655

- 1** Disconnect the Tire Pressure Monitoring System module connector, CA072.

2 Measure the resistance between:

RB009, harness side	Battery
Pin 2	Negative terminal

Is the resistance less than 10,000 ohms?
Yes
 REPAIR the short circuit. This circuit contains

intermediate connector, RB001. For additional information, refer to the wiring diagram. Clear the DTC and run an On Demand Self Test (ODST) using the manufacturer approved diagnostic system to confirm rectification.

No

INSTALL a new Tire Pressure Monitoring System module. REFER to: (204-04 Wheels and Tires)

[Tire Pressure Monitoring System \(TPMS\) Module - Convertible](#) (Removal and Installation),
[Tire Pressure Monitoring System \(TPMS\) Module - 2-Door](#) (Removal and Installation).

E6: CHECK WHETHER THE SHORT CIRCUIT IS IN THE HARNESS OR THE MODULE

1 Disconnect the Tire Pressure Monitoring System module connector, CA072.

2 Measure the resistance between:

RB009, harness side	Battery
Pin 2	Positive terminal

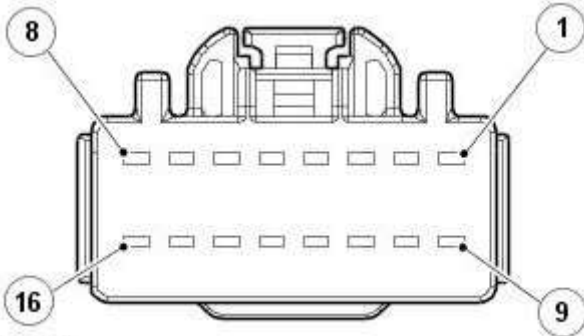

E63655

Is the resistance less than 10,000 ohms?

Yes

REPAIR the short circuit. This circuit contains intermediate connector, RB001. For additional information, refer to the wiring diagram. Clear the DTC and run an On Demand Self Test (ODST) using the manufacturer approved diagnostic system to confirm rectification.

No

INSTALL a new Tire Pressure Monitoring System module. REFER to: (204-04 Wheels and Tires)

[Tire Pressure Monitoring System \(TPMS\) Module - Convertible](#) (Removal and Installation),
[Tire Pressure Monitoring System \(TPMS\) Module - 2-Door](#) (Removal and Installation).

E7: CHECK WHETHER THE SHORT CIRCUIT IS IN THE HARNESS OR THE MODULE

1 Disconnect the Tire Pressure Monitoring System module connector, CA072.

2 Measure the resistance between:

RB009, harness side	Battery
Pin 1	Negative terminal

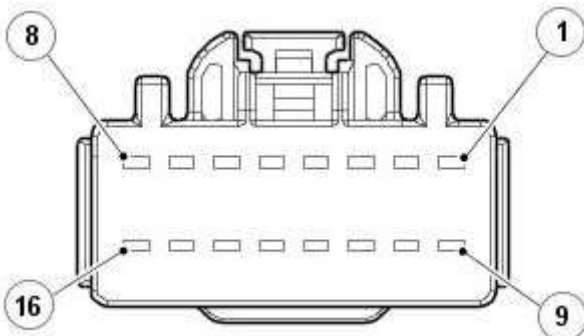

E63655

Is the resistance less than 10,000 ohms?

Yes

REPAIR the short circuit. This circuit contains intermediate connector, RB001. For additional information, refer to the wiring diagram. Clear the DTC and run an On Demand Self Test (ODST) using the manufacturer approved diagnostic system to confirm rectification.

No

INSTALL a new Tire Pressure Monitoring System module. REFER to: (204-04 Wheels and Tires)

[Tire Pressure Monitoring System \(TPMS\) Module - Convertible](#) (Removal and Installation),
[Tire Pressure Monitoring System \(TPMS\) Module - 2-Door](#) (Removal and Installation).

E8: CHECK WHETHER THE SHORT CIRCUIT IS IN THE HARNESS OR THE MODULE

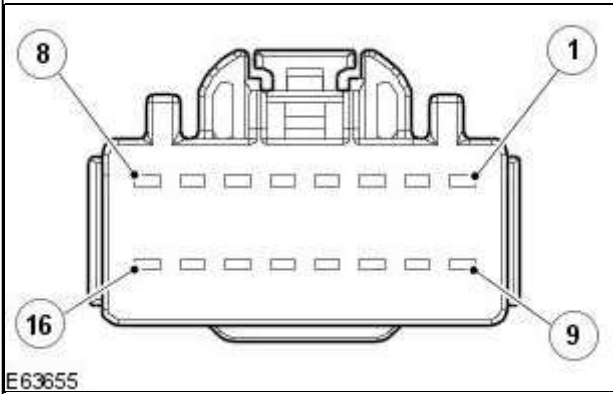

1 Disconnect the Tire Pressure Monitoring System module connector, CA072.

2 Measure the resistance between:

RB009, harness side	Battery
Pin 1	Positive terminal

Is the resistance less than 10,000 ohms?

Yes
 REPAIR the short circuit. This circuit contains intermediate connector, RB001. For additional information, refer to the wiring diagram. Clear the DTC and run an On Demand Self Test (ODST) using the manufacturer approved diagnostic system to confirm rectification.

No
 INSTALL a new Tire Pressure Monitoring System module. REFER to: (204-04 Wheels and Tires)
[Tire Pressure Monitoring System \(TPMS\) Module - Convertible](#) (Removal and Installation),
[Tire Pressure Monitoring System \(TPMS\) Module - 2-Door](#) (Removal and Installation).

E9: CHECK THE INITIATOR CIRCUIT FOR HIGH RESISTANCE

1 Measure the resistance between:

CA072, harness side	RB009, harness side
Pin 8	Pin 2

Is the resistance greater than 5 ohms?

Yes
 REPAIR the high resistance circuit. This circuit contains intermediate connector, RB001. For additional information, refer to the wiring diagram. Clear the DTC and run an On Demand Self Test (ODST) using the manufacturer approved diagnostic system to confirm rectification.

No
[GO to E10.](#)

E10: CHECK THE INITIATOR CIRCUIT FOR HIGH RESISTANCE

1 Measure the resistance between:

CA072, harness side	RB009, harness side
Pin 7	Pin 1

Is the resistance greater than 5 ohms?

Yes
 REPAIR the high resistance circuit. This circuit contains intermediate connector, RB001. For additional information, refer to the wiring diagram. Clear the DTC and run an On Demand Self Test (ODST) using the manufacturer approved diagnostic system to confirm rectification.

No
 INSTALL a new rear right hand low-frequency initiator. REFER to: [Tire Pressure Monitoring System \(TPMS\) Rear Antenna](#) (204-04 Wheels and Tires, Removal and Installation).

PINPOINT TEST F : MISSING, INCOMPATIBLE OR DEFECTIVE RUNNING TIRE LOW PRESSURE SENSOR OR RECEIVER	
TEST CONDITIONS	DETAILS/RESULTS/ACTIONS
F1: CHECK FOR CORRECT WHEEL AND TIRE ASSEMBLY AND TIRE LOW PRESSURE SENSOR	
	<p>1 Establish that a full size running wheel and tire assembly has a tire low pressure sensor installed. As a visual confirmation, a tire low pressure sensor has a metal valve stem rather than a rubber one and cannot be installed to a mini/space saver spare wheel.</p> <p>Is a full size wheel and tire assembly with tire low pressure sensor installed?</p> <p>Yes GO to F2.</p> <p>No Install the correct wheel and tire assembly or tire low pressure sensor, of correct frequency, in accordance with that defined in the manufacturer approved diagnostic system new tire low pressure sensor application.</p>
F2: CHECK FOR ADDITIONAL DTCS	
	<p>1 Remove the Tire Pressure Monitoring System power supply fuse and re-install it. Clear DTCs and leave the vehicle stationary for 15 minutes, then drive it at a speed greater than 15.5 mph (25 kph) continuously for at least 10 minutes. (Note: If the vehicle speed drops below this value, the drive time to complete the test will need to be increased.)</p> <p>The use of the manufacturer approved diagnostic system, and the datalogger signal 'Tire pressure monitor system status – learn mode status' will verify the completion of the test when the value returns to 'Inactive'.</p>
	<p>2 Check for additional DTCs C1A5631, C1A5831, C1A6031, C1A6231, with identical time stamps.</p> <p>Have all four DTCs logged with identical time stamps in the tire pressure monitoring system module?</p> <p>Yes Replace the tire pressure monitoring system radio frequency receiver. REFER to: Tire Pressure Monitoring System (TPMS) Receiver (204-04 Wheels and Tires, Removal and Installation).</p> <p>No GO to F3.</p>
F3: VERIFY THE POSITION OF THE DEFECTIVE TIRE LOW PRESSURE SENSOR	
	<p>1 Check tire pressure monitoring system DTCs.</p> <p>Are any C1AXX31 DTCs logged?</p> <p>Yes Install the correct tire low pressure sensor, of correct frequency, in accordance with that defined in the manufacturer approved diagnostic system new tire low pressure sensor application, to the position identified by the logged DTC. REFER to: Tire Low Pressure Sensor (204-04 Wheels and Tires, Removal and Installation).</p> <p>No No further action is required. (Note: The use of the manufacturer approved diagnostic system, and the datalogger signal 'Tire pressure monitor system status – learn completed successfully' will verify the successful completion of the test.)</p>

PINPOINT TEST G : LOCALIZATION FAILURE	
TEST CONDITIONS	DETAILS/RESULTS/ACTIONS
G1: CHECK FOR ADDITIONAL DTCS	
	<p>1 Check for additional DTCs: C1A5711, C1A5712, C1A5713, C1A5911, C1A5912, C1A5913, C1A6111, C1A6112, C1A6113, C1A6311, C1A6312, C1A6313.</p> <p>Are any of the DTCs listed above also logged?</p> <p>Yes Refer to the DTC Index and remedial actions.</p> <p>No GO to G2.</p>
G2: CHECK FOR ADDITIONAL DTCS	
	<p>1 Check for additional DTCs: C1A5631, C1A5831, C1A6031 or C1A6231</p> <p>Is a C1A5631, C1A5831, C1A6031 or C1A6231 DTC also logged?</p> <p>Yes Refer to the DTC Index and remedial actions.</p> <p>No GO to G3.</p>
G3: CHECK INITIATOR INSTALLATION	
	<p>1 Check for correct installation of Initiator. REFER to: (204-04 Wheels and Tires) Tire Pressure Monitoring System (TPMS) Front Antenna (Removal and Installation), Tire Pressure Monitoring System (TPMS) Rear Antenna (Removal and Installation).</p> <p>Is the Initiator correctly installed?</p> <p>Yes GO to G4.</p> <p>No Rectify as required. REFER to: (204-04 Wheels and Tires) Tire Pressure Monitoring System (TPMS) Front Antenna (Removal and Installation),</p>

[Tire Pressure Monitoring System \(TPMS\) Rear Antenna](#) (Removal and Installation).

G4: CHECK FOR SHORT CIRCUIT IN INITIATOR HARNESS

1	Locate and remove module blue connector L.
2	Measure the resistance across the relevant initiator circuits within the blue connector.
Is the resistance less than 1 Ohm?	
Yes	
A value of less than 1 Ohm indicates a short circuit, rectify the short circuit as required.	
No	
Install the correct tire low pressure sensor, of correct frequency, in accordance with that defined in the manufacturer approved diagnostic system new tire low pressure sensor application, to the position identified by the logged DTC. REFER to: Tire Low Pressure Sensor (204-04 Wheels and Tires, Removal and Installation).	

PINPOINT TEST H : SPARE TIRE LOW PRESSURE SENSOR NO OPERATION

TEST CONDITIONS	DETAILS/RESULTS/ACTIONS
H1: ESTABLISH THE TYPE OF SPARE WHEEL AND TIRE ASSEMBLY INSTALLED	
1	Establish the type of spare wheel and tire assembly Installed.
Is the spare wheel a mini/space saver type?	
Yes	
Tire low pressure sensors are not installed to mini/space-saver spare wheels. Tire low pressure sensors are installed to full size spare wheels only. The DTC is to be ignored and no repair action is required.	
No	
GO to H2.	
H2: ESTABLISH THAT THE SPARE WHEEL HAS A TIRE LOW PRESSURE SENSOR INSTALLED	
1	Establish that the spare wheel has a tire low pressure sensor installed, considering the following additional information:
<ul style="list-style-type: none"> • a) As a visual confirmation, the tire low pressure sensor has a metal valve stem rather than a rubber one. 	
Is a tire low pressure sensor installed?	
Yes	
GO to H3.	
No	
A new spare tire low pressure sensor should be installed. Note: Refer to the note above the DTC index about replacing components which may remain under manufacturer warranty. Refer to the relevant section of the workshop manual.	
H3: CONFIRM OPERATION OF THE SPARE WHEEL PRESSURE SENSOR	
1	Deflate the spare tire, in close proximity to the vehicle, until it is completely deflated.
2	Complete an ignition cycle to ignition on and verify that the instrument cluster reports a spare tire pressure warning for approximately 20 seconds.
3	Re-inflate the spare tire, in close proximity to the vehicle, to the recommended spare tire pressure.
4	Complete an ignition cycle to ignition on and verify that the instrument cluster no longer reports a spare tire pressure warning.
Does the instrument cluster continue to report a spare tire pressure warning?	
Yes	
GO to H4.	
No	
No repair action is required. It is possible that the customer may have placed items in the vehicle's luggage compartment that prevented correct RF reception.	
H4: VERIFY THAT THE SPARE TIRE LOW PRESSURE SENSOR ID HAS BEEN CORRECTLY PROGRAMMED TO THE MODULE	
1	Remove tire low pressure sensor. Record the 8 character hexadecimal ID written on the casing.
2	Use the approved diagnostic system to read the spare tire sensor ID from the module. Refer to the relevant procedure in the workshop manual.
3	Compare the IDs from steps 1 & 2.
Do the IDs match?	
Yes	
Replace the spare tire low pressure sensor. Refer to the relevant installation section in the workshop manual. The identification for the sensor must be programmed into the tire pressure monitoring system module using the manufacturer approved diagnostic system. The identification code is provided on a label with the complete assembly and is also printed on the casing of each sensor.	
No	
Program the spare tire sensor ID, recorded in step 1, to the module using the approved diagnostic system. The identification code is provided on a label with the complete assembly and is also printed on the casing of each sensor. Repeat test to ensure correct operation. GO to H3.	

PINPOINT TEST I : C1D1912 TIRE PRESSURE MONITORING SYSTEM EXTERNAL RECEIVER DATA LINE CIRCUIT SHORT TO POWER

TEST CONDITIONS	DETAILS/RESULTS/ACTIONS				
I1: C1D1912 VERIFY EXTERNAL RECEIVER DATA LINE CIRCUIT SHORT TO POWER					
	<ol style="list-style-type: none"> 1 Ignition off. 2 Disconnect the Tire Pressure Monitoring System Receiver electrical connector, CA131. 3 Measure the resistance between <table border="1" style="width: 100%; border-collapse: collapse;"> <tr> <td style="text-align: center;">CA131, harness side</td> <td style="text-align: center;">Battery</td> </tr> <tr> <td style="text-align: center;">Pin 1</td> <td style="text-align: center;">Positive terminal</td> </tr> </table> <p>Is the resistance less than 5 Ohms? Yes GO to I2. No GO to I3.</p>	CA131, harness side	Battery	Pin 1	Positive terminal
CA131, harness side	Battery				
Pin 1	Positive terminal				
I2: C1D1912 CHECK THE EXTERNAL RECEIVER DATA LINE CIRCUIT FOR SHORT CIRCUIT TO POWER					
	<ol style="list-style-type: none"> 1 Disconnect the Tire Pressure Monitoring System Control Module electrical connector, CA109. 2 Measure the resistance between <table border="1" style="width: 100%; border-collapse: collapse;"> <tr> <td style="text-align: center;">CA131, harness side</td> <td style="text-align: center;">Battery</td> </tr> <tr> <td style="text-align: center;">Pin 1</td> <td style="text-align: center;">Positive terminal</td> </tr> </table> <p>Is the resistance less than 5 Ohms? Yes REPAIR the short circuit in wiring harness. No GO to I4.</p>	CA131, harness side	Battery	Pin 1	Positive terminal
CA131, harness side	Battery				
Pin 1	Positive terminal				
I3: C1D1912 CHECK THE TIRE PRESSURE MONITORING SYSTEM EXTERNAL RECEIVER FOR SHORT CIRCUIT TO POWER					
	<ol style="list-style-type: none"> 1 Reconnect the Tire Pressure Monitoring System Receiver electrical connector, CA131. 2 Using manufacturer approved diagnostic system run On Demand Self Test (0x0202). <p>Is the DTC C1D1912 set? Yes Replace Tire Pressure Monitoring Receiver. No Investigate possible cause of intermittent failure.</p>				
I4: C1D1912 CHECK THE TIRE PRESSURE MONITORING SYSTEM CONTROL MODULE FOR SHORT CIRCUIT TO POWER					
	<ol style="list-style-type: none"> 1 Reconnect the Tire Pressure Monitoring System Control Module electrical connector, CA109. 2 Reconnect the Tire Pressure Monitoring System Receiver electrical connector, CA131. 3 Using manufacturer approved diagnostic system run On Demand Self Test (0x0202). <p>Is the DTC C1D1912 set? Yes Replace Tire Pressure Monitoring System Control Module. No Investigate possible cause of intermittent failure.</p>				

PINPOINT TEST J : C1D1987 TIRE PRESSURE MONITORING SYSTEM EXTERNAL RECEIVER DATA LINE MISSING MESSAGE

TEST CONDITIONS	DETAILS/RESULTS/ACTIONS				
J1: C1D1987 VERIFY EXTERNAL RECEIVER DATA LINE MISSING MESSAGE					
	<ol style="list-style-type: none"> 1 Using manufacturer approved diagnostic system run On Demand Self Test (0x0202). <p>Is the DTC C1D1987 set? Yes GO to J2. No GO to J5.</p>				
J2: C1D1987 CHECK EXTERNAL RECEIVER DATA LINE CIRCUIT					
	<ol style="list-style-type: none"> 1 Ignition off. 2 Disconnect the Tire Pressure Monitoring System Receiver electrical connector, CA131. 3 Disconnect the Tire Pressure Monitoring System Control Module electrical connector, CA109 4 Measure the resistance between <table border="1" style="width: 100%; border-collapse: collapse;"> <tr> <td style="text-align: center;">CA131, harness side</td> <td style="text-align: center;">CA109, harness side</td> </tr> <tr> <td style="text-align: center;">Pin 1</td> <td style="text-align: center;">Pin4</td> </tr> </table> 	CA131, harness side	CA109, harness side	Pin 1	Pin4
CA131, harness side	CA109, harness side				
Pin 1	Pin4				

	<p>Is the resistance less than 5 ohms? Yes GO to J3. No REPAIR the high resistance/open circuit in wiring harness.</p>
J3: C1D1987 CHECK EXTERNAL RECEIVER	
	<p>1 Reconnect the Tire Pressure Monitoring System Control Module electrical connector, CA109 2 Reconnect the Tire Pressure Monitoring System Receiver electrical connector, CA131. 3 Using manufacturer approved diagnostic system run On Demand Self Test (0x0202). Is the DTC C1D1987 set? Yes Replace Tire Pressure Monitoring Receiver.GO to J4. No Investigate possible cause of intermittent failure.</p>
J4: C1D1987 CHECK TIRE PRESSURE MONITORING SYSTEM CONTROL MODULE	
	<p>1 Using manufacturer approved diagnostic system run On Demand Self Test (0x0202). Is the DTC C1D1987 set? Yes Replace Tire Pressure Monitoring System Control Module. No Test is complete. No further action is required.</p>
J5: C1D1987 CHECK WHEELS HAVE TIRE SENSORS INSTALLED	
	<p>NOTE: As a visual check, a tire low pressure sensor has a metal valve stem rather than a rubber one and cannot be installed to a mini/space saver spare wheel. 1 Check that all full size running wheel and tire assemblies have tire low pressure sensors installed. Is a full size wheel and tire assembly with tire low pressure sensor installed to all running wheel positions? Yes GO to J6. No If agreed with the customer install correct tire low pressure sensors in accordance with that defined in the manufacturer approved diagnostic system new tire low pressure sensor application, as required. <small>(Note: Confirm why the vehicle has non-Tire Pressure Monitoring System wheel & tire assemblies installed before installing tire low pressure sensors, which are not to be claimed under vehicle warranty.)</small></p>
J6: C1D1987 CHECK TIRE SENSOR COMPATIBILITY TO TIRE PRESSURE MONITORING SYSTEM RECEIVER	
	<p>1 Remove tire low pressure sensor from 1 wheel. 2 Verify the tire low pressure sensor part number from the information on the casing. Is the tire low pressure sensor the correct part for the vehicle? Yes Replace Tire Pressure Monitoring Receiver. Carry out the following to verify repair. Remove the Tire Pressure Monitoring System power supply fuse and re-install it. Clear DTCs and leave the vehicle stationary for 15 minutes, then drive it at a speed greater than 15.5 mph (25 kph) continuously for at least 10 minutes. <small>(Note: If the vehicle speed drops below this value, the drive time to complete the test will need to be increased. The use of the manufacturer approved diagnostic system, and the datalogger signal 'Tire pressure monitor system status – learn mode status' will verify the completion of the test when the value returns to 'Inactive'.)</small> No Install the correct tire low pressure sensor, of correct frequency, in accordance with that defined in the manufacturer approved diagnostic system new tire low pressure sensor application, to the position(s) identified. <small>(Note: Confirm why the vehicle has incorrect Tire Pressure Monitoring System wheel & tire assemblies installed before installing tire low pressure sensors, which are not to be claimed under vehicle warranty.)</small></p>