



Functional Descriptions Automatic-Transmission



6HP19
6HP26
6HP32



Introduction / note

This brief technical description is intended to supply the necessary technical information on the components, construction and function of the automatic transmission.

Information status: **June 01**

For amendments and additions to the technical data, please refer to the latest Technical After-Sales Service information.

Reproduction, duplication or translation either wholly or in part are not permitted unless the authors' written permission has been obtained.



6HP19 automatic transmission



6HP26 automatic transmission



6HP32 automatic transmission

6HPxx Functional Description - Contents

Item	Page
Introduction / note	2
Contents	3
Coloured sectioned diagram - 6HP19	4
Key to coloured sectioned diagram - 6HP19	5
Brief description - general	6
Lepelletier planetary gear set	7
-- single-web planetary gear train	7
-- double planetary gear train	8
Description of individual components	11
-- Hydrodynamic torque converter (operating principle)	11
-- 6HP26 torque converter (sectioned diagram) without / with torsional vibration damper	12
-- Converter lock-up clutch (2 GWK + torsional vibration damper)	14
* Hydraulic flow in converter (lock-up clutch (WK) open)	15
* Hydraulic flow in converter (WK closed)	16
-- Oil pump	17
-- Shift elements	18
* Clutches / brakes / sectioned drawings	18
* Clutch - sectioned drawings	19
* Action of shift elements	20
-- Shift overlap control	21
-- Parking lock	22
* mechanical version	22
* electrical version	23
Transmission control area	25
-- Control elements and overview of shift system - E and M shift	25
-- Description of gears / power flow, 1st to 6th gear + Reverse	33
-- Hydraulic circuit diagram (DIN) (valve geometry, M / E shift)	49
-- Hydraulic and electronic (Mechatronik) control units	51
* General (ESD protection)	52
* Sectioned diagrams of individual components (M and E shift)	59
* Brief description of valves	69
* Description of solenoid valves, pressure regulator	71
* Position of pressure unions	72
* Threaded connections on components	76
* Electronic module (electronic control unit)	78
* Mechatronik block circuit diagrams	81
-- Technical data - 6HP19, 6HP26, 6HP32	85

6HP 19 automatic transmission

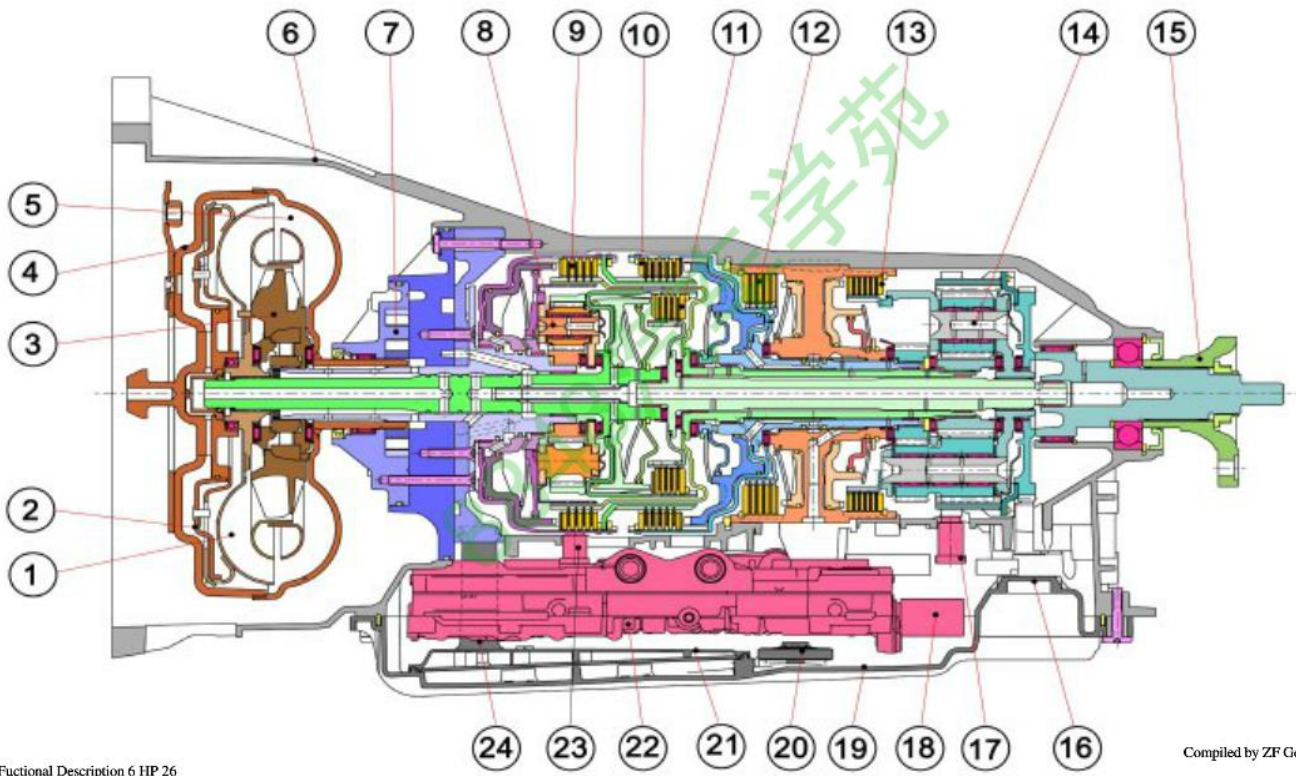

Key to coloured sectioned diagram 6HP19

- | | | | |
|----|--|-----|--|
| 1 | Turbine | } | Torque converter |
| 2 | Converter lock-up clutch piston | | |
| 3 | Stator | | |
| 4 | Converter cover | | |
| 5 | Pump | | |
| 6 | Transmission housing | | (With integral converter dome and extension) |
| 7 | Oil pump | | (half-moon pump version) |
| 8 | Front single planetary gear set | | |
| 9 | Clutch | "A" | |
| 10 | Clutch | "B" | |
| 11 | Clutch | "E" | |
| 12 | Brake | "C" | |
| 13 | Brake | "D" | |
| 14 | Rear double planetary gear set | | |
| 15 | Output flange | | |
| 16 | Oil filler plug | | |
| 17 | Output speed sensor | | |
| 18 | Pressure regulating valves | | |
| 19 | Oil pan | | |
| 20 | Magnet | | |
| 21 | Oil mesh strainer | | |
| 22 | Hydraulic control unit | | (Mechatronik) |
| 23 | Turbine speed sensor | | |
| 24 | Suction pipe to oil strainer | | |

Brief description - general

The ZF 6HP26 automatic transmission has been developed for vehicles with an engine torque of up to 600 Newton-metres (Nm).

To match the installed position of the engine, the automatic transmission is also arranged longitudinally. It uses the planetary gear train principle, with hydraulic-electronic control; the hydraulic and electronic control units form a composite element that is installed as a single unit inside the automatic transmission and referred to as "Mechatronik".

A new feature is decoupling of the transmission when the vehicle is at a standstill, that is to say instead of the engine remaining connected to the converter and the vehicle being prevented from moving by applying the brake, the converter is disconnected and only a minimum rotating load remains. This has the effect of further reducing fuel consumption. The electronic transmission control uses a newly developed shift strategy known as "A S I S" (Adaptive Shift Strategy).

For this, please refer to the separate functional description.

The 6HP26 automatic transmission is about 13 % lighter than the previous 5-speed unit, accelerates 5 % faster and uses about 7 % less fuel. It also contains fewer components:

- o 5-speed transmission app. 660 parts
- o 6-speed transmission app. 470 parts

The 6-speed automatic transmission is 5 centimetres shorter than the 5-speed transmission. Engine power reaches the transmission via a hydrodynamic torque converter with integral converter lock-up clutch.

The input torque limits are:

6HP19	max. torque:	420 Nm
6HP26	max. torque:	600 Nm
6HP32	max. torque:	750 Nm

The 6 forward gears and 1 reverse gear are obtained from a single-web planetary gear set followed by a double planetary gear set.

Using these Lepelletier-type gear sets, it was possible to obtain 6 forward speeds.

The single-web planetary gear set consists of:

- 1 sunwheel
- 4 planetary gears meshing with it
- 1 planetary gear carrier
- 1 ring gear or annulus

The following double planetary gear set consists of:

- 2 sunwheels of different sizes
- 3 short planetary gears meshing with them
- 3 long planetary gears meshing with them
- 1 planetary gear carrier
- 1 ring gear or annulus

Single-web planetary gear set

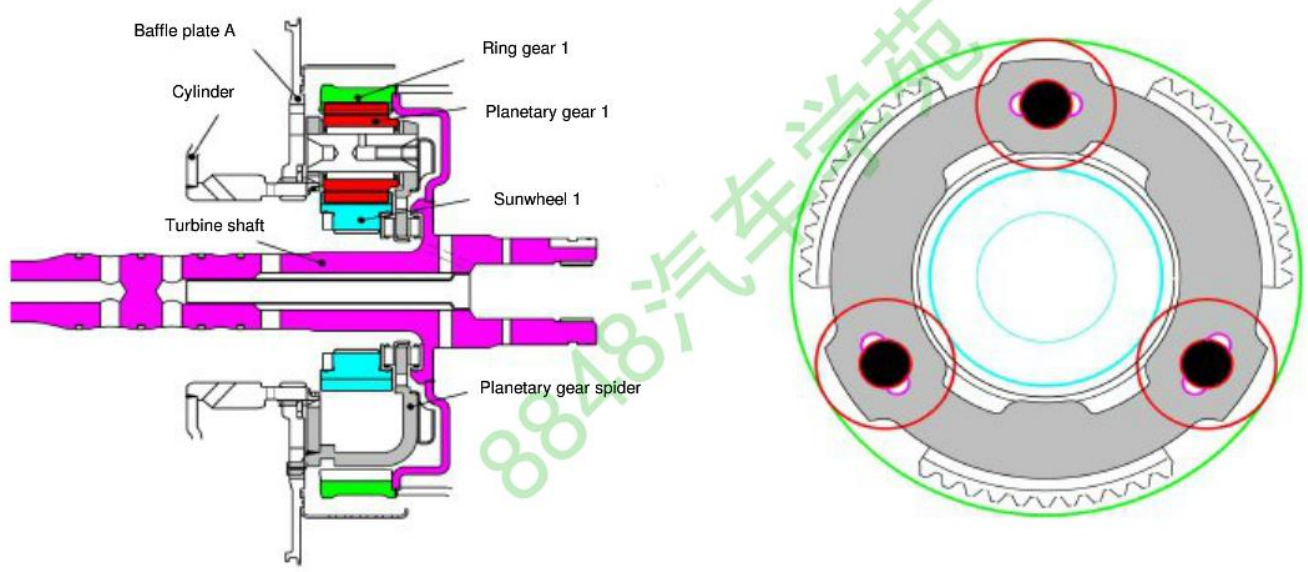

Rear double planetary gear set

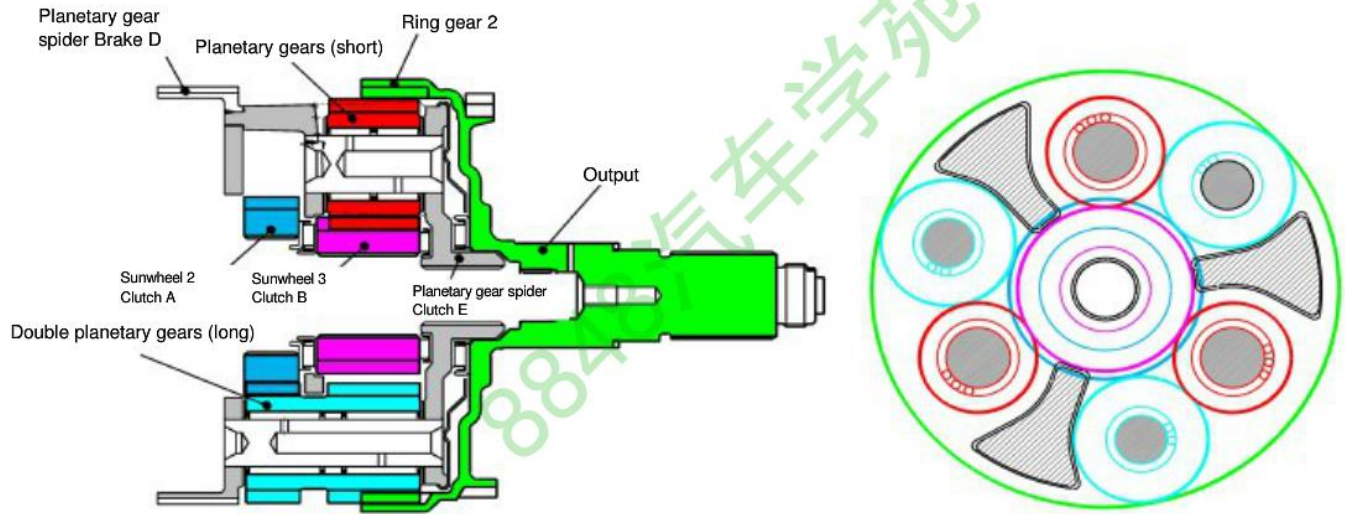

Single-web planetary gear set



Rear double-web planetary gear set



Gear ratios

The ratios for the various gears are obtained by diverting the incoming torque through various elements of the planetary gear train and braking other elements.

Output is always via the ring gear of the second, downstream planetary gear set.
See also description of power flow.

The mechanical gear ratios are:

Gear:	1st	2nd	3rd	4th	5th	6th	Rev.
Ratio:	4.171	2.340	1.521	1.143	0.867	0.691	3.403

Schematic diagram of 6HP26 / 6HP32 transmission

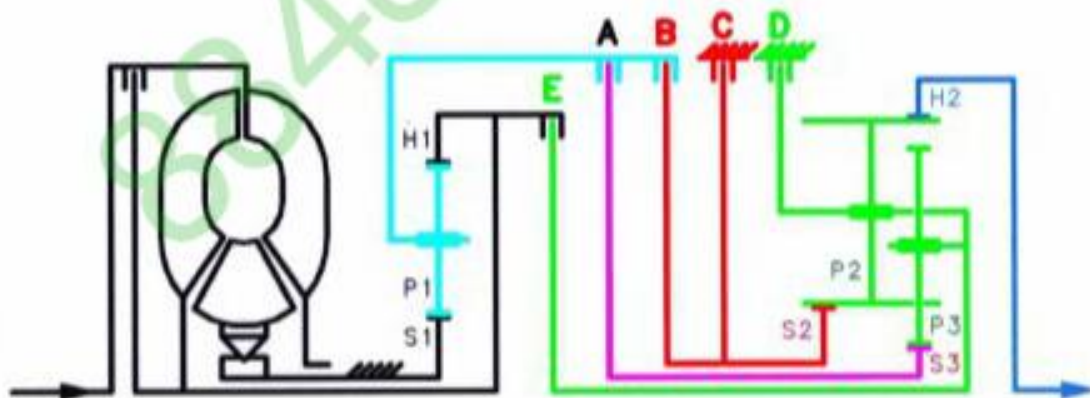

Description of individual components

The hydrodynamic torque converter

Converter operating principle

The torque converter consists of the impeller, the turbine wheel, the reaction element (stator) and the oil content needed to transmit the torque.

The impeller, which is driven by the engine, imparts a circular flow to the oil in the converter. This oil strikes the turbine wheel, which causes the flow to change its direction.

The oil flows out of the turbine wheel close to the hub and strikes the stator, where its direction is changed again to a direction suitable for re-entering the impeller.

The change in direction at the stator generates a torque reaction that increases the torque reaching the turbine.

The ratio between turbine and impeller torque is referred to as torque multiplication or conversion.

The greater the difference in speeds of rotation at the impeller and turbine, the greater the increase in torque; The maximum increase is obtained when the turbine wheel is stationary. As turbine wheel speed increases, the amount of torque multiplication gradually drops.

When the turbine wheel is rotating at about 85 % of the impeller speed, torque conversion reverts to 1, that is to say torque at the turbine wheel is no higher than at the impeller.

The stator, which is prevented from rotating backwards by a freewheel and the shaft in the transmission housing, runs freely in the oil flow and overruns the freewheel. From this point on, the converter acts only as a fluid coupling. During the torque conversion process, the stator ceases to rotate and bears against the housing via the freewheel.

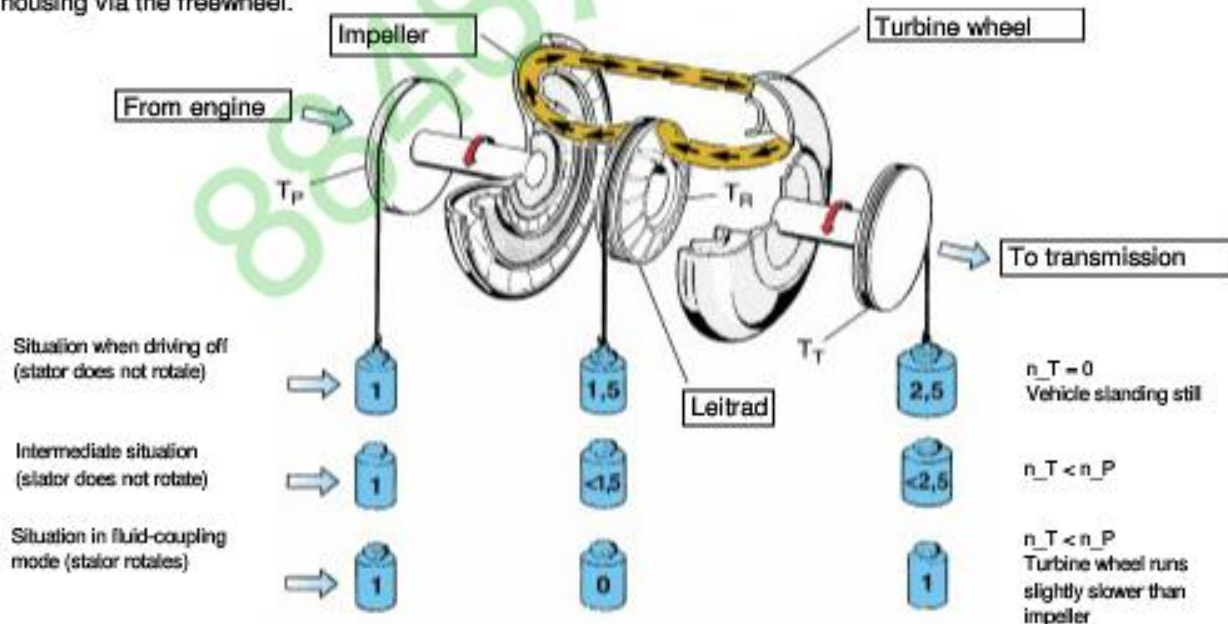

6HP26 - torque converter without torsional vibration damper

torque converter
W260 S - 2GWK

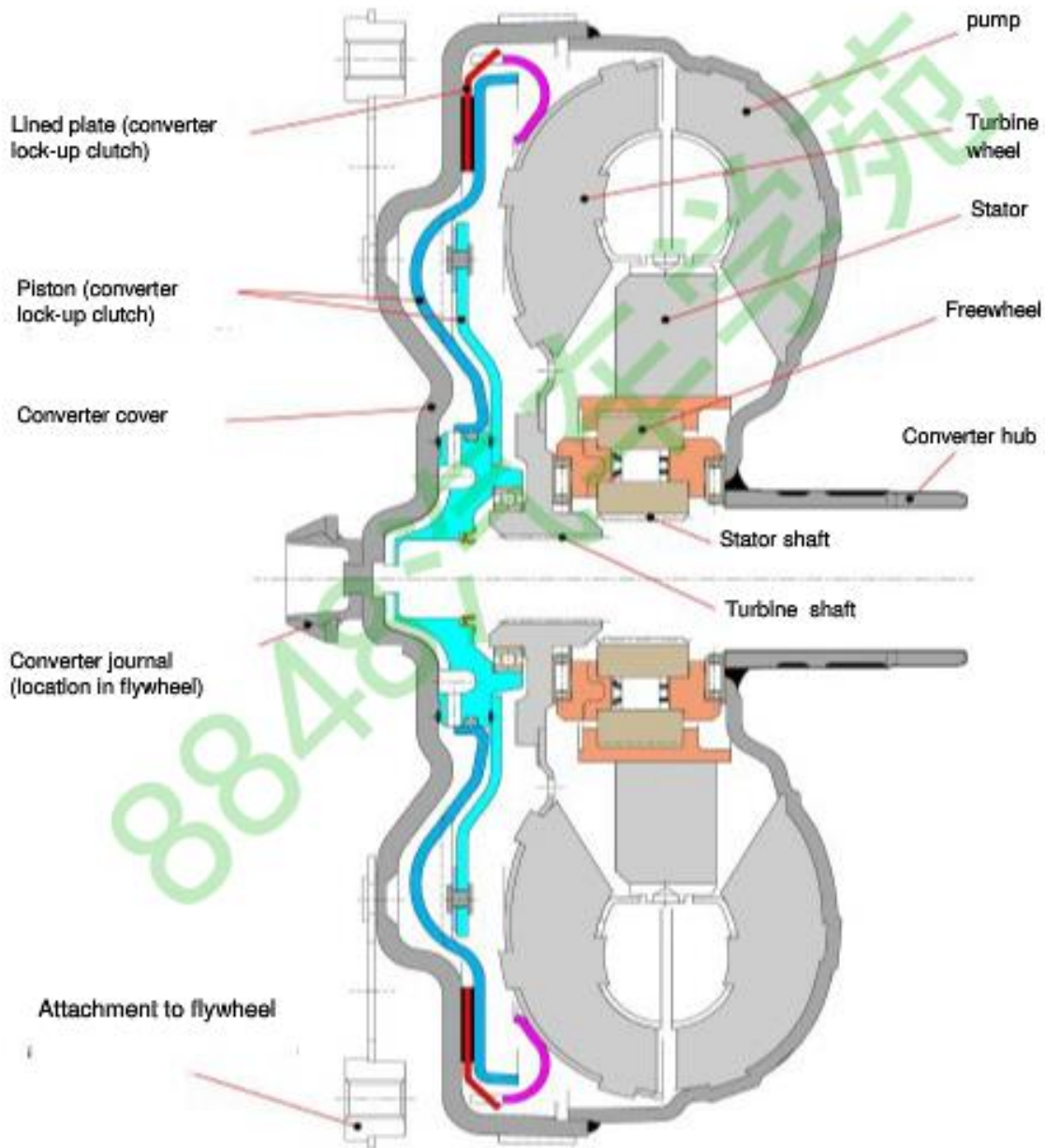

6HP26 torque converter with torsional vibration damper

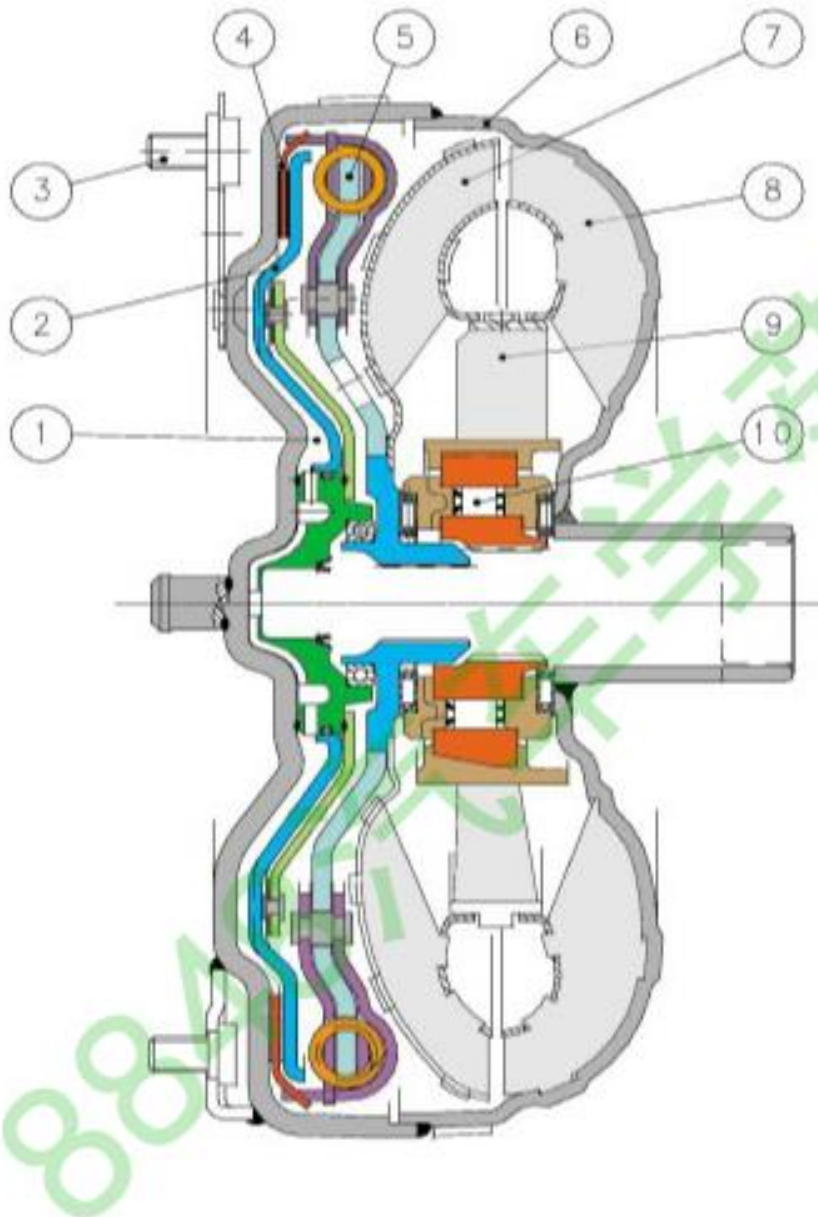

Upper half: W 260 S - 2 GWK / TD
 Lower half: W 280 S - 2 GWK / TD

1	Space behind lock-up clutch	6	Converter cover
2	Lock-up clutch piston	7	Turbine
3	n_mot	8	Impeller
4	Lined plate of lock-up clutch	9	Stator
5	Torsional vibratiuon damper	10	Stator freewheel

Converter lock-up clutch

The converter lock-up clutch (WK) is a device that eliminates slip in the torque converter and therefore helps to keep fuel consumption to a minimum.

The WK is engaged and released by the control system. During the actuating phase, a slight difference is selected between the impeller and turbine wheels. This transmits vibration caused by engine rotation to the transmission, after it has been additionally suppressed by a torsional vibration damper.

This procedure ensures optimum shift quality and improves the noise pattern.

Pressure at the WK piston is determined by an electronic pressure control valve (EDS 6).

See also the oil flow diagram.

In accordance with the vehicle manufacturer's wishes, the lock-up clutch can be controlled and engaged in any gear from 1 to 6. The standstill decoupling facility is new. Instead of the engine continuing to drive the converter when the vehicle comes to a standstill (so that the foot has to be kept on the brake), the converter is disconnected from the driveline so that only a slight residual load remains. This further reduces fuel consumption. Decoupling is by actuating clutch A in the transmission, and is dependent on load and output speed.

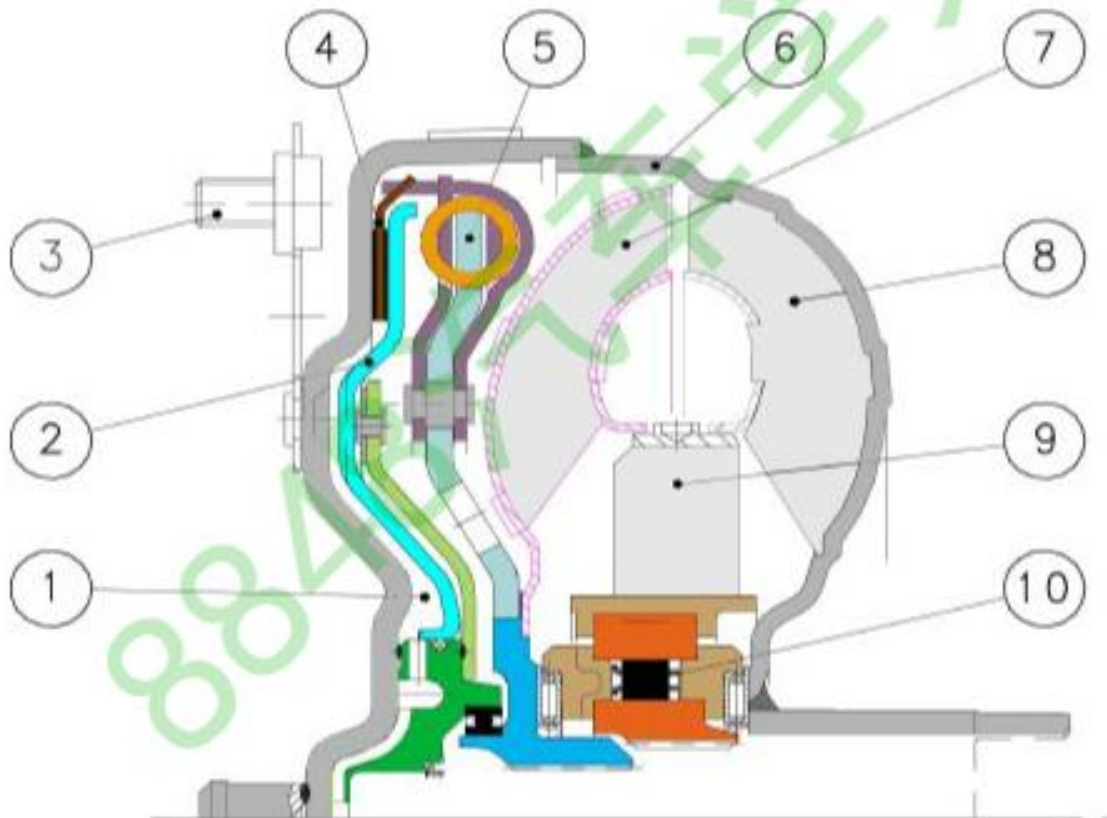

1	Space behind lock-up clutch	6	Converter cover
2	Lock-up clutch piston	7	Turbine
3	n_mot	8	Impeller
4	Lined plate of lock-up clutch	9	Stator
5	Torsional vibration damper	10	Stator freewheel

Hydraulic and mechanical flow in the converter

WK_auf $n_{Mot} > n_{Turbine}$

When released (conversion mode), oil pressures behind the lock-up clutch piston (1) and in the turbine area (2) are equalised. The direction of flow is through the turbine shaft and the area behind the piston into the turbine area.

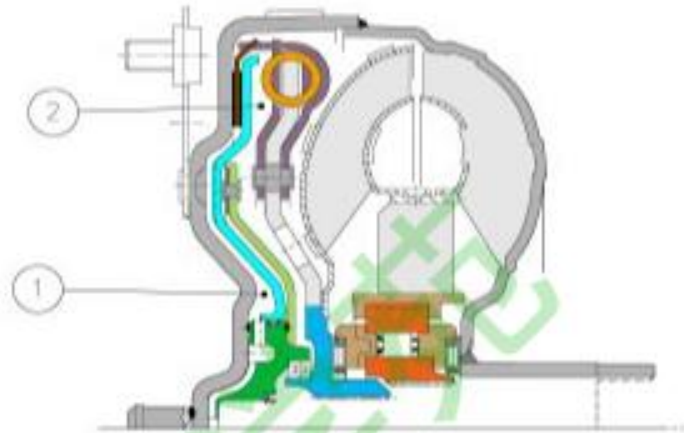

Oil flow, WK_released

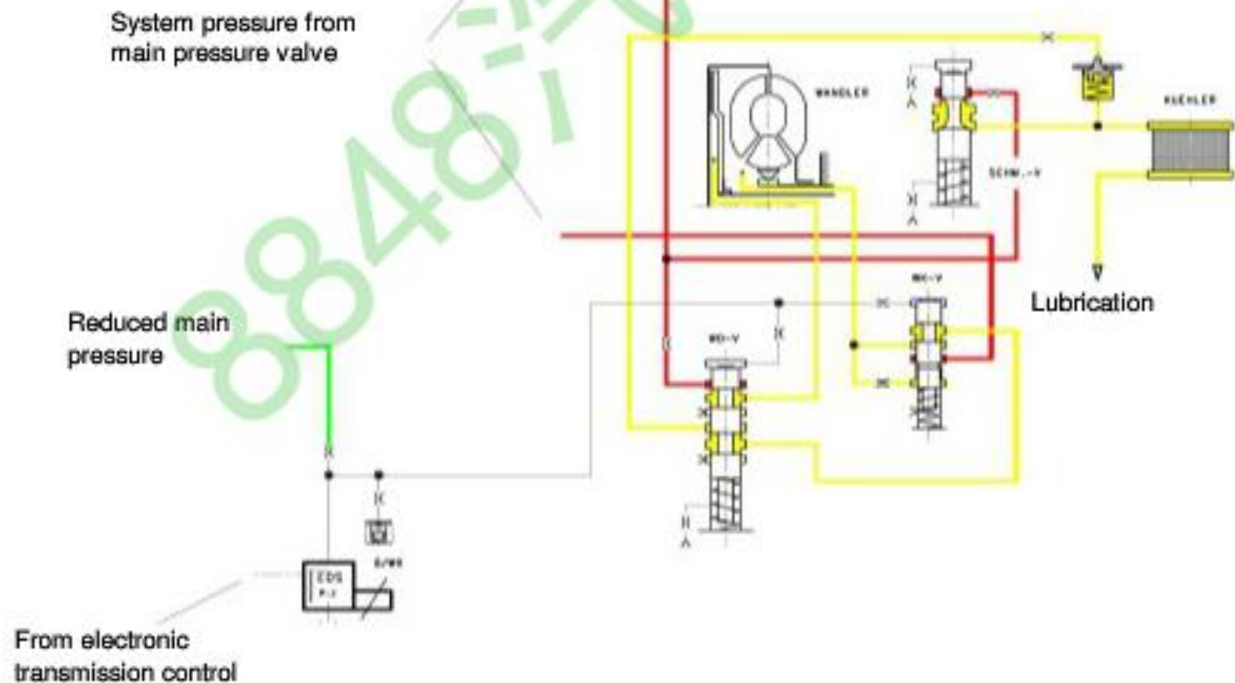

Hydraulic and mechanical flow in converter

WK_zu **n_Mot = n_Turbine**

To engage the lock-up clutch (4) the direction of oil flow is changed (reversed) by a valve in the hydraulic control unit. At the same time the space behind the lock-up clutch piston (1) is vented.

Oil pressure extends from the turbine area (3) to the lock-up clutch piston and presses it against cover (5) (outer shell of converter). This locks the turbine wheel (6) by way of the lined disc between the piston and the cover and enables the drive to pass either without slip or with limited slip to the planetary gear train in normal operating conditions.

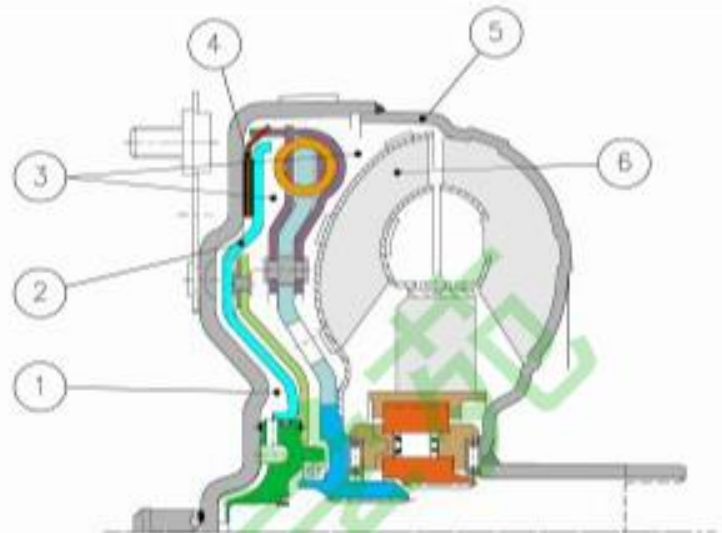

Oil flow WK_engaged

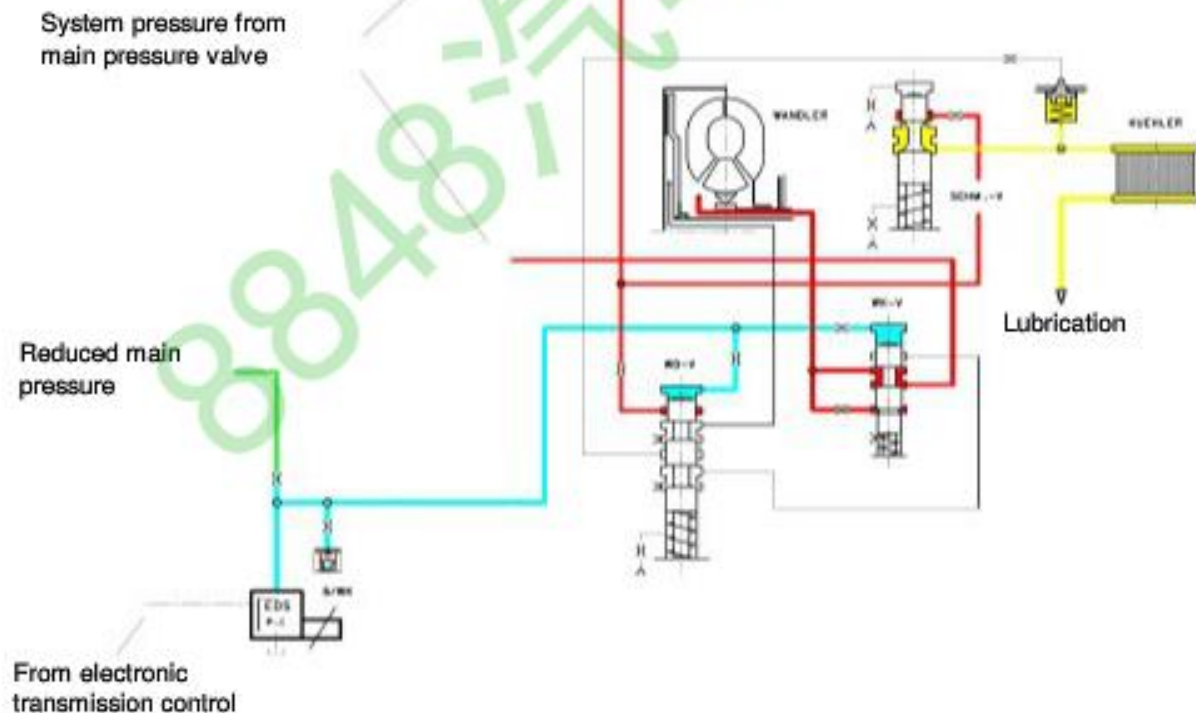

Oil pump (half-moon pump)

The oil pump is of "half-moon" pattern and delivers app. 16 sq. cm of oil per revolution. It is located between the torque converter and the transmission housing.

The converter is supported in the pump by a needle roller bearing. The pump is driven directly from the engine via the converter shell and supplies oil to the transmission and the hydraulic control unit.

The pump draws in oil through a filter and delivers it at high pressure to the main pressure valve in the hydraulic control unit. This valve adjusts the pressure and returns excess oil to the oil pan.

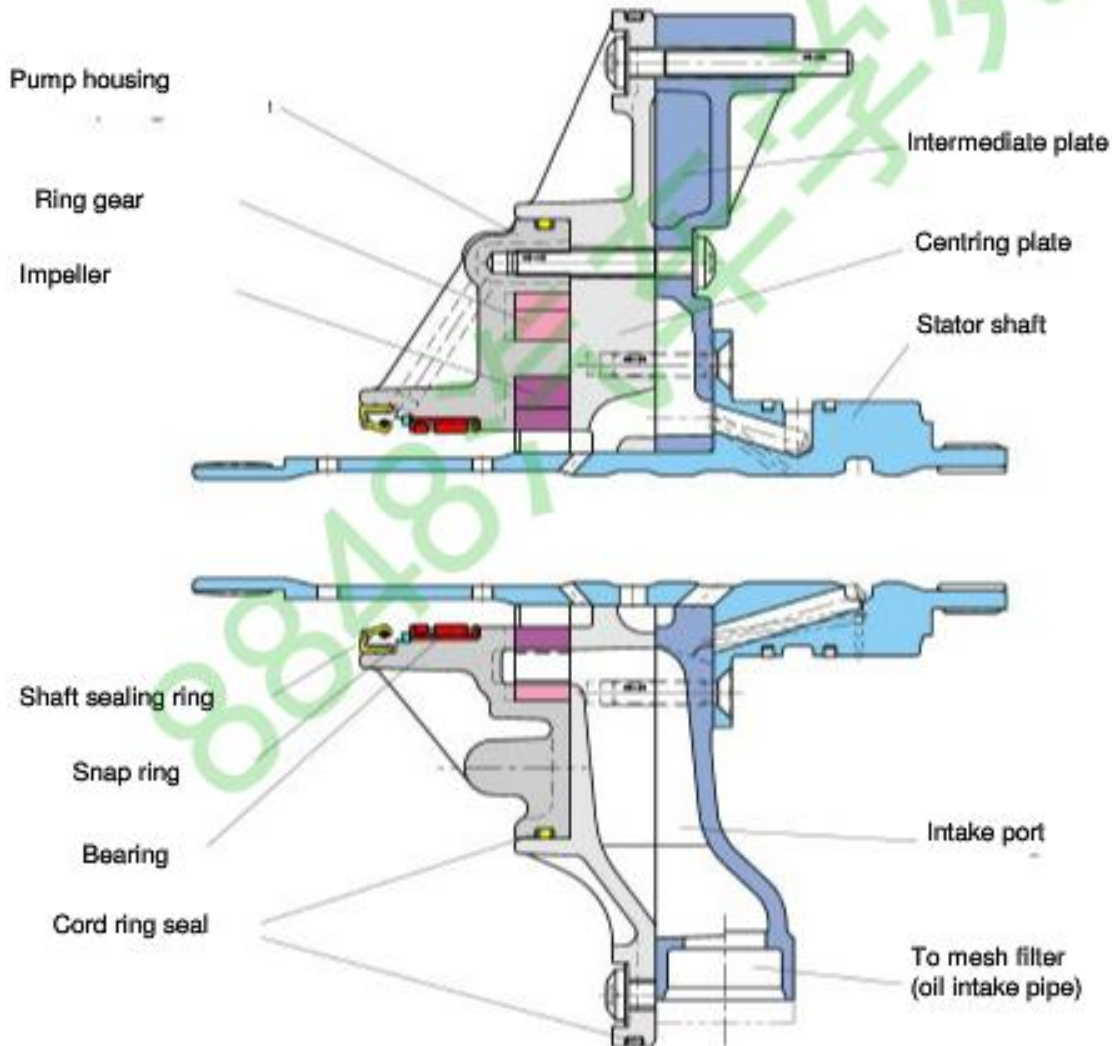

Shift elements

The other shift elements in addition to the converter lock-up clutch (WK) are:

- three rotating multi-plate clutches A, B and E
- two fixed multi-disc brakes C and D

All gear shifts from 1st to 6th or from 6th to 1st are power-on overlapping shifts, that is to say during the shift one of the clutches must continue to transmit the drive at lower main pressure until the other clutch is able to accept the input torque.

The shift elements, clutches or brakes are engaged hydraulically. The oil pressure is built up between the cylinder and the piston, thus pressing the clutch plates together.

When the oil pressure drops, the cup spring pressing against the piston moves it back to its original position.

The purpose of these shift elements is to perform in-load shifts with no interruption to traction.

Multi-plate clutches A, B and E supply power from the engine to the planetary gear train; multi-disc brakes C and D bear against the transmission housing in order to achieve a torque reaction effect.

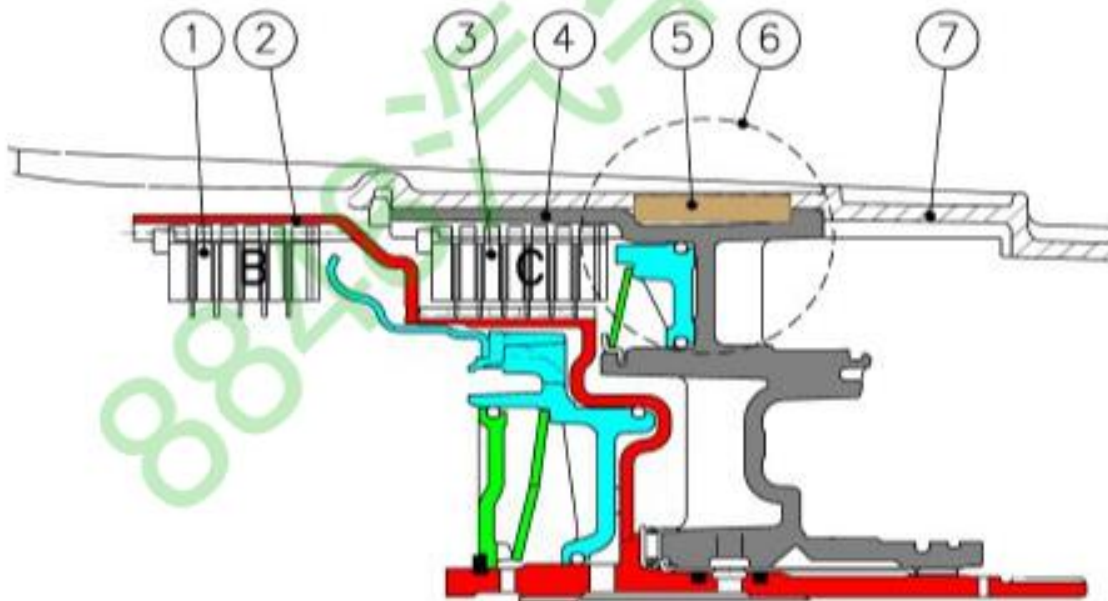

- | | |
|--|---|
| 1 Multi-plate clutch B | 5 Shaft key |
| 2 Clutch cylinder B, outer plate carrier | 6 Brake cylinder C, outer plate carrier
(bears against transmission housing) |
| 3 Multi-disc brake C | 7 Transmission housing |
| 4 Brake cylinder C, outer plate carrier | |

Example of multi-plate clutch (clutch E)

Clutch E is equalised in terms of dynamic pressure, that is to say its piston is exposed to the oil flow on both sides, in order to prevent pressure build up in the clutch as the speed increases. This equalisation process is achieved by baffle plate (1) and pressure-free oil supply via lubricating passage (2), through which the space between piston and baffle plate is filled with oil.

The advantages of this dynamic pressure equalisation are:

- reliable clutch engagement and release in all speed ranges
- improved shift refinement

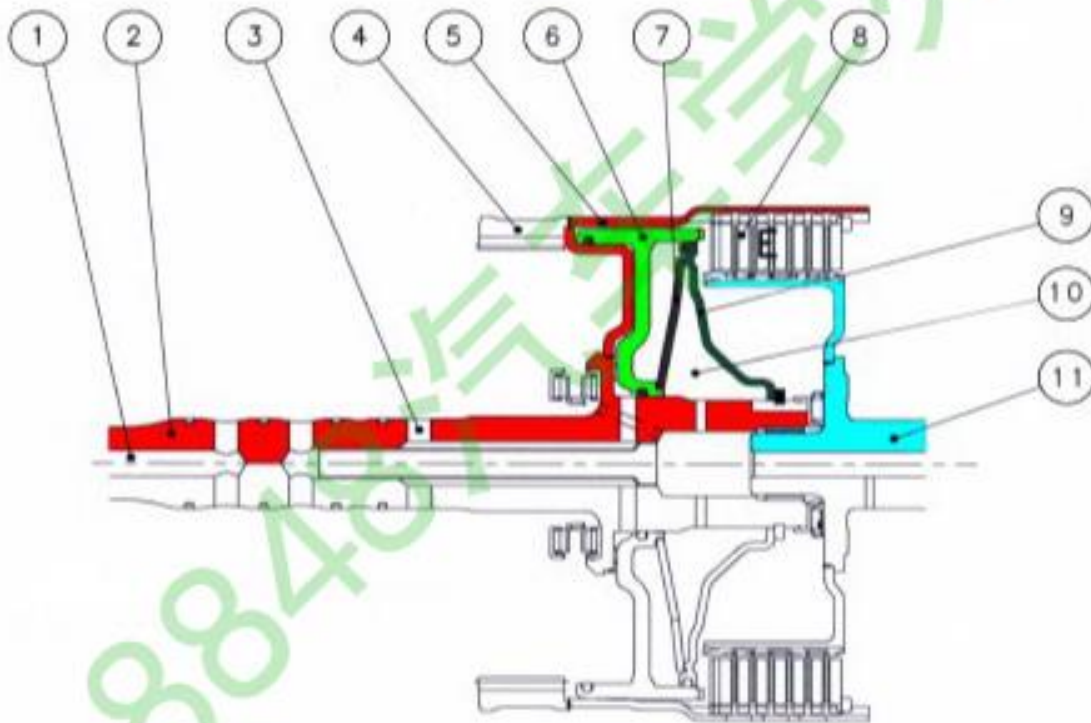

1	Lubricating oil passage	7	Cup spring
2	Turbine shaft	8	Clutch plate cluster
3	Main pressure supply to clutch E	9	Baffle plate
4	Ring gear, planetary gear set 1	10	Space for dynamic pressure equalisation
5	Cylinder E (outer plate carrier)	11	Inner plate carrier E
6	Piston E	12	Space between piston and cylinder

Action of shift elements

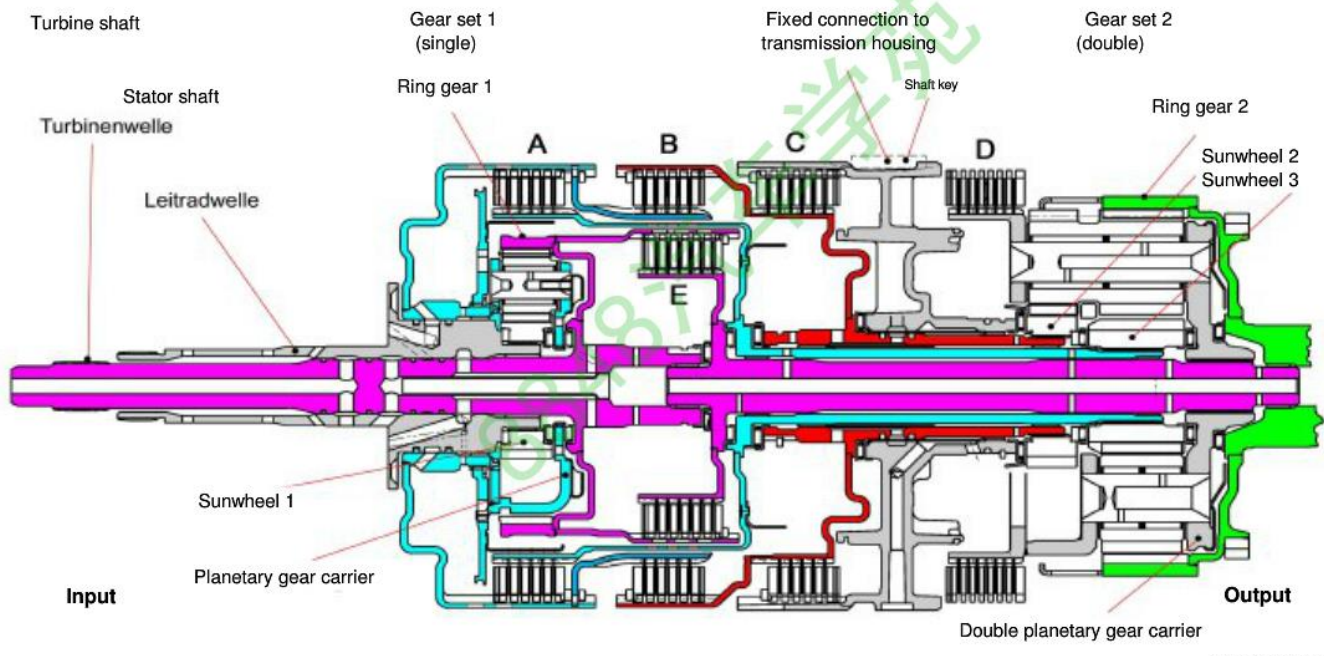

Shift overlap control

When overlap gear shifts take place, freewheels are not used but are replaced by suitable actuation of the relevant clutches (electronic-hydraulically). This enables both weight and space to be saved.

The electronic-hydraulic shift action is obtained by means of various valves in the hydraulic control unit, actuated by pressure regulators.

They engage or disengage the relevant clutches or brakes at the correct moments.

The electronic control unit is combined with the hydraulic control unit and installed as a single unit in the transmission (Mechatronik).

Schematic diagram of shift overlap control

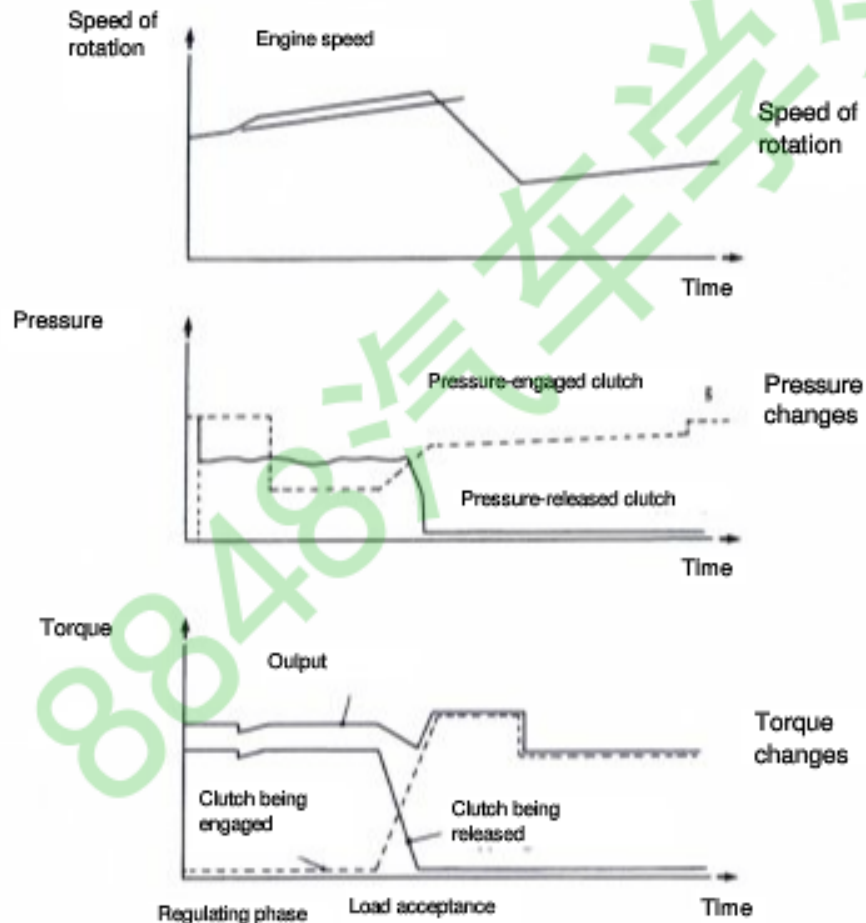

Parking lock

General:

The parking lock is a device that prevents the vehicle from rolling away out of control. It is engaged when the vehicle is standing still, either purely mechanically or electrically depending on the transmission version.

The mechanical version uses a wire cable from the selector lever unit in the vehicle to the transmission.

The electrical version is engaged by a steering-wheel pushbutton (on the SZL = steering-wheel switching centre) with a cable leading to the transmission.

The parking lock mechanism inside the transmission is as in previous versions.

The parking lock acts by inserting a pawl into the teeth of the parking lock gearwheel on the transmission output shaft; this prevents the rear wheels from turning by way of the propeller shaft and rear-axle final drive.

1.) Mechanical version:

On the purely mechanical version, the parking lock is engaged at the vehicle's selector lever, which is connected by a wire cable to the detent disc in the transmission.

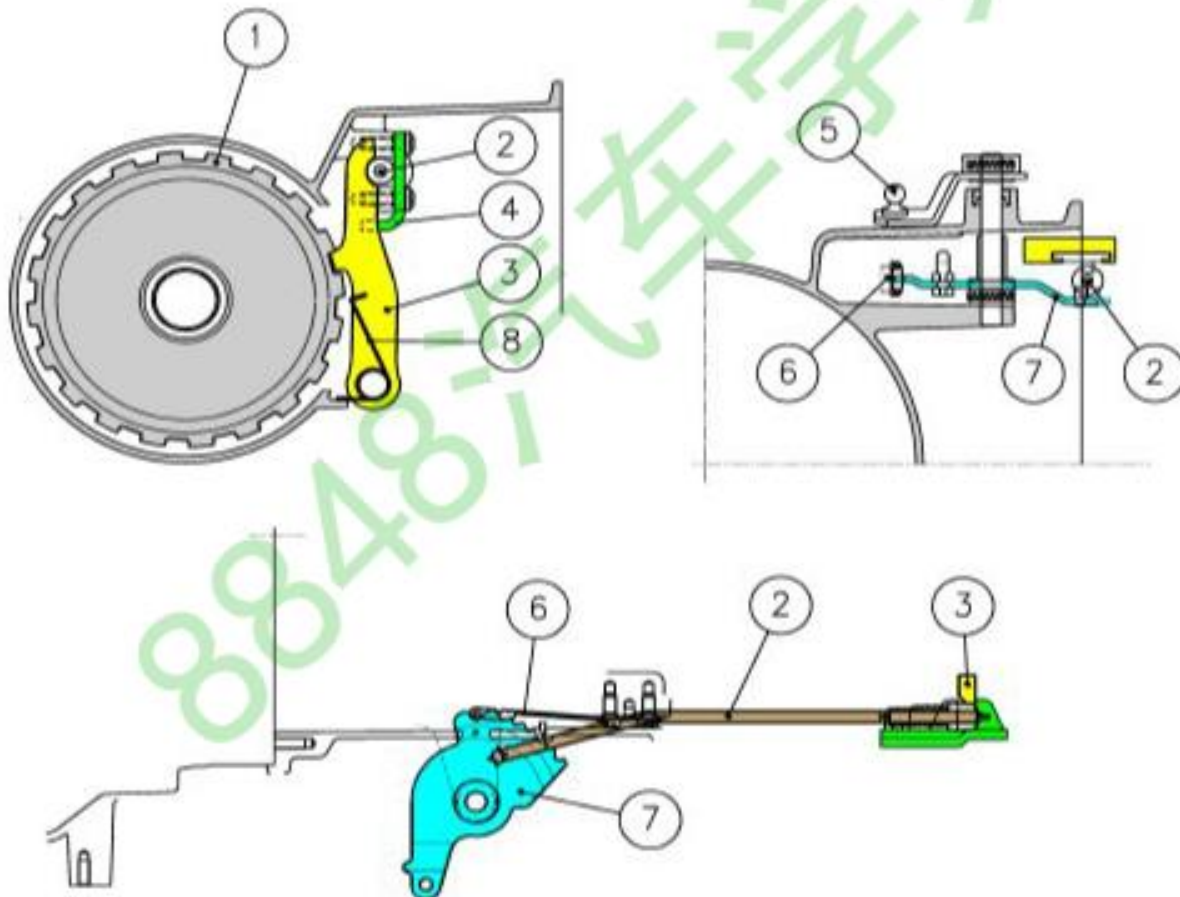

- 1 Parking lock gearwheel
- 2 Connecting rod
- 3 Parking lock pawl
- 4 Guide plate

- 5 Selector lever (gear shift lever)
- 6 Detent spring
- 7 Detent disc
- 8 Torsion spring

2.) Electrical version:

On the electrical version, the parking lock is engaged by a mechanical spring system in the transmission and secured electrically. All drive positions are also selected electrically. The detent disc in the transmission is omitted, and replaced by a parking disc and lock cylinder with solenoid valve (MV3). The parking lock is actuated by way of the position switch (hall-effect sensor) on the e-module.

Function:

When the park position is deselected, MV2 resets the parking lock valve in the hydraulic control unit. The main pressure that is present there reaches the parking lock cylinder and pushes the piston back to release the lock.

MV3 is energised and locks the piston additionally by means of the ball catches.

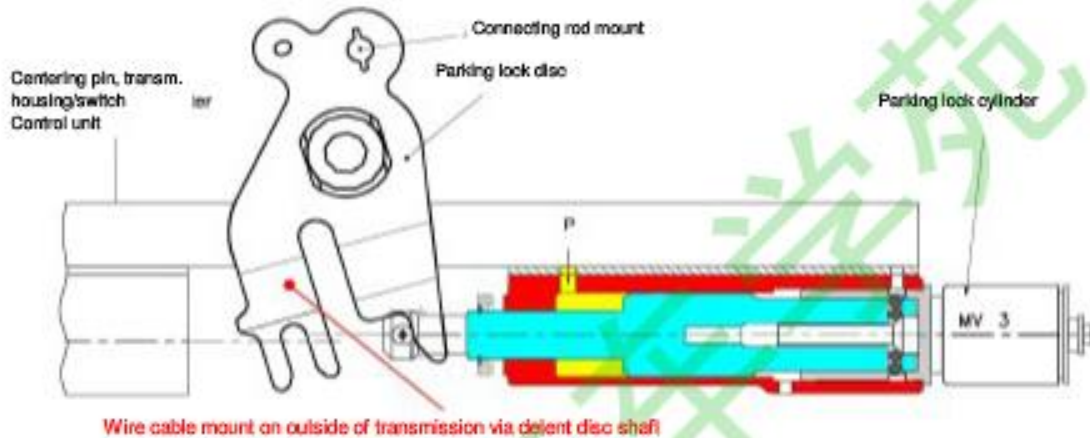

When the park position is selected, MV3 is de-energised. The mechanical piston lock at the ball catches is released and the piston is able to move. In this situation, MV2 is also de-energised. The parking lock valve returns to its rest position and vents the parking lock cylinder. The pre-tensioned torsion spring at the parking lock disc pulls the piston in the "park" direction and engages the parking lock.

An additional wire cable at the parking lock disc can be used to release the parking lock manually in certain situations (for instance an electrical failure in the emergency program).

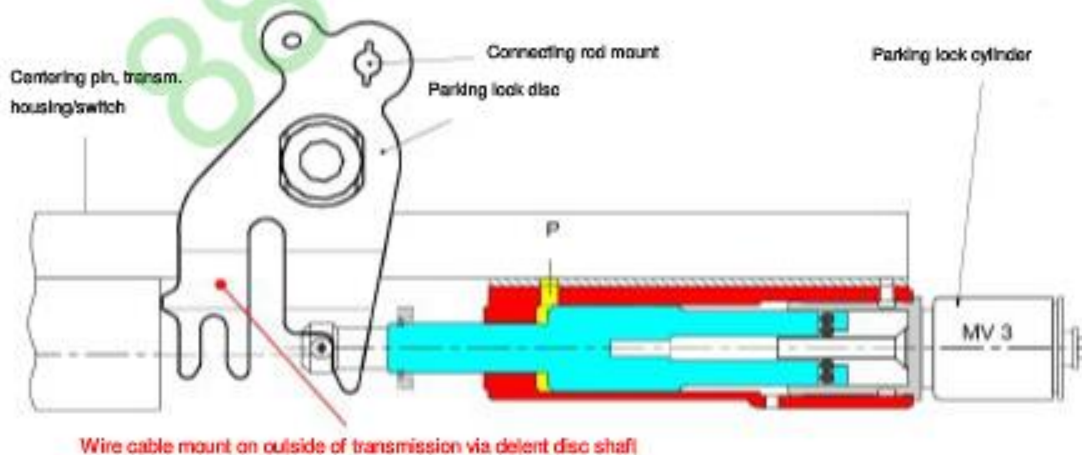

Parking lock operating elements

The wire cable or linkage to the selector gate inside the vehicle is supplied by the vehicle manufacturer.

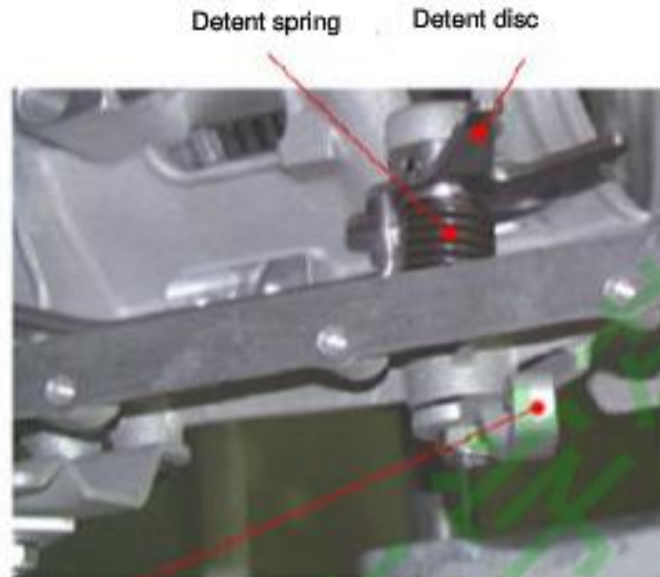

Selector lever:
 Connecting wire cable for emergency release with E shift
 Connecting wire cable to shift gate with M shift.

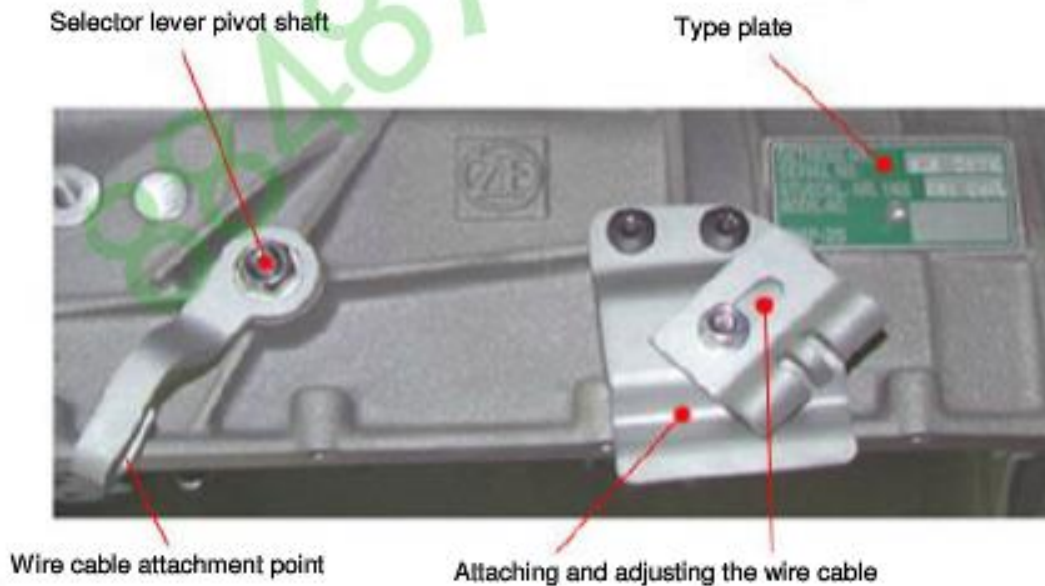

Transmission control area - BMW

Controls and gear shift display

There are various forms of control available for the 6-speed automatic transmissions. They are as specified by individual customers and either electrically or mechanically operated. The selector lever can be either on the centre console or on the steering column.

1. Mechanical shift (BMW wiring)

- * Automatic transmission with Mechatronik
- * Digital Motor / Diesel Electronics (DME / DDE)
- * Car Access System (CAS) - a development of the electronic immobiliser (EWS)
- * With Steptronic, selector lever on centre console

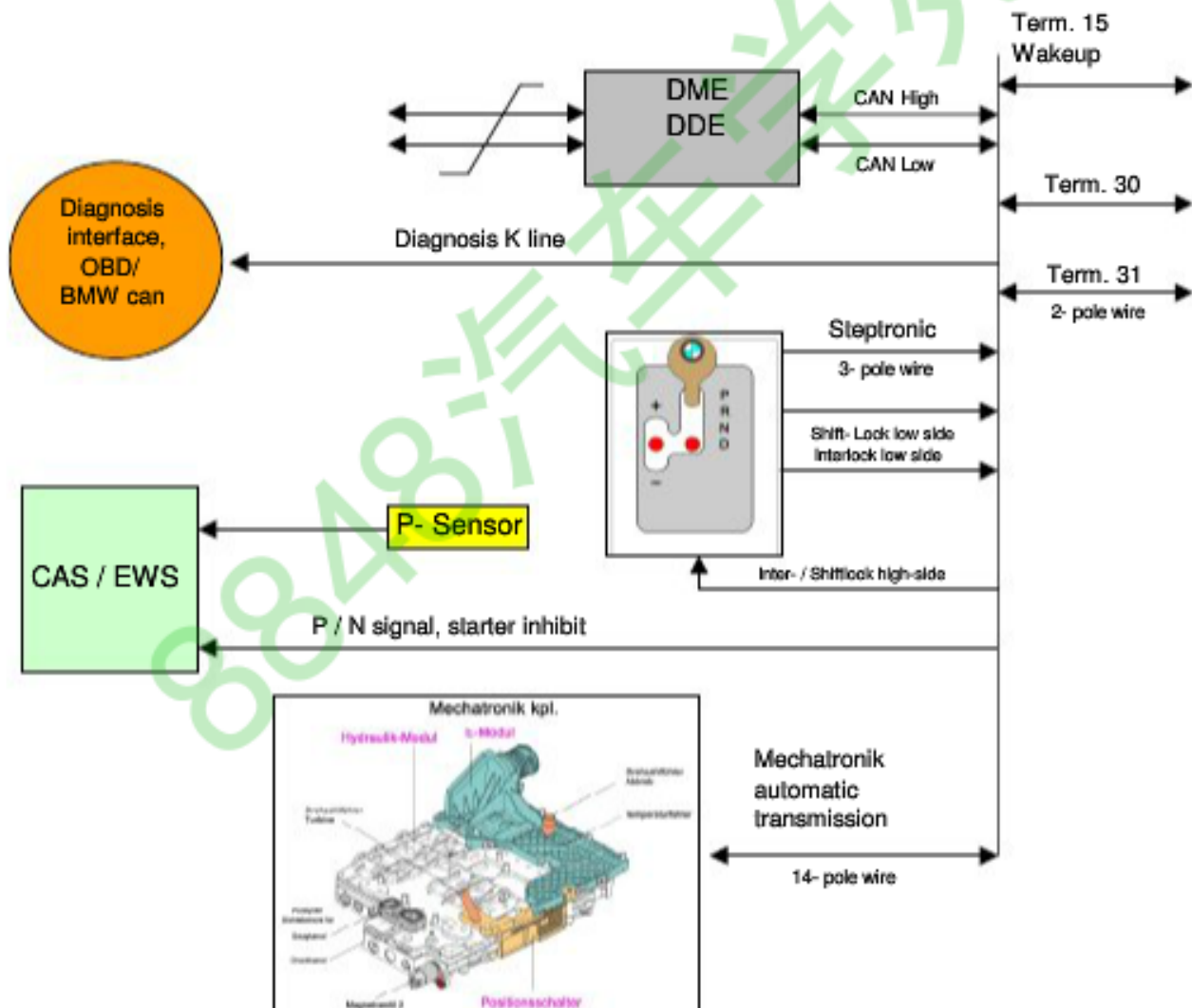

Selector lever positions (location on centre console)

The selector can be used to obtain the following gears mechanically.

Position / function

P = Park. Select only when vehicle is standing still.

Correct procedure:

First apply the handbrake, then select position P.

R = Reverse. Select only with the vehicle at a standstill and the engine idling.

N = Neutral. With the car standing still, apply the handbrake as well to prevent it from creeping forward. During the journey, only select neutral in an emergency situation in order to avoid a skid.

D = Drive. Automatic gear selection for forward travel in regular driving conditions. Shifts are automatic between 1 - 6 / 6 - 1. To select specific gears, see "Tip" mode (M program).

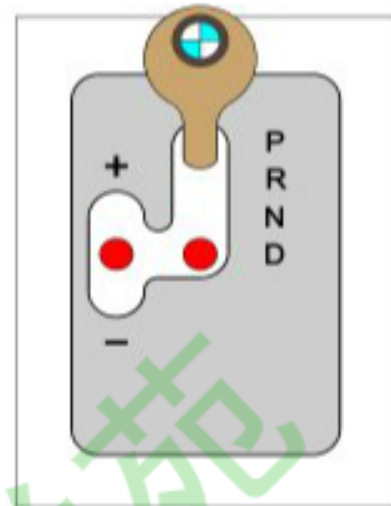

Program selection:

The various programs are selected according to the position of the lever in the gate.

Three basic programs are available:

Blue, position (D)	=	XE program (Adaptive Transmission Control AGS)
Yellow, position (S)	=	S program (Adaptive Transmission Control AGS)
Yellow, acc. to (+) or (-)	=	Tip mode (manual selection)

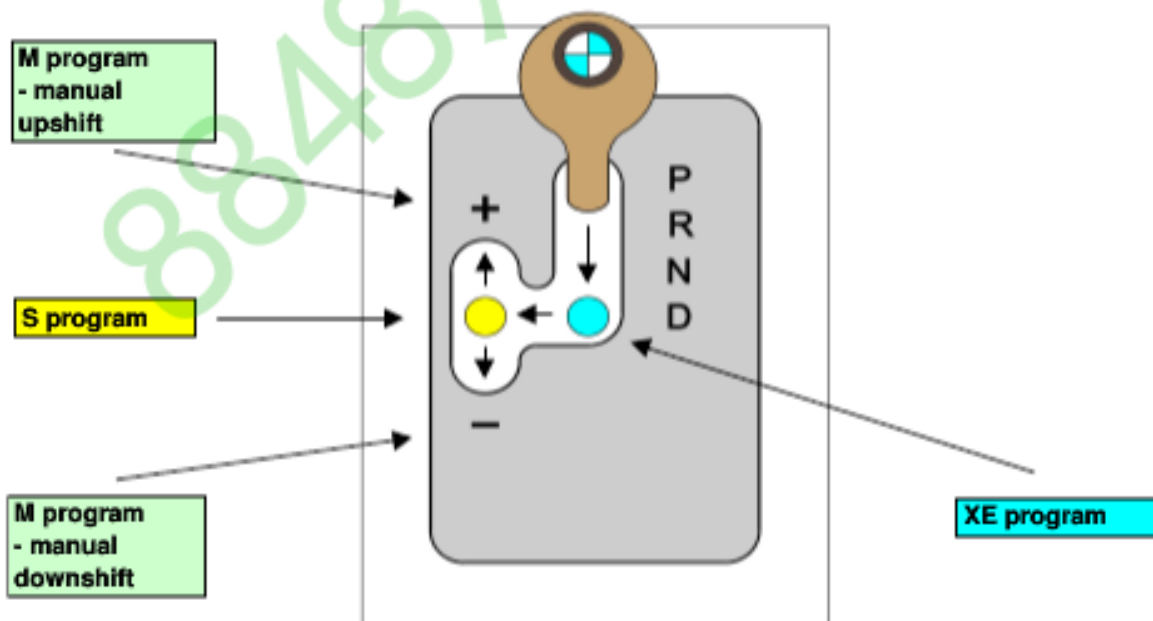

XE program (AGS)

Standard drive program in position D

The adaptive transmission control includes various driving programs, for example:

- Towing a trailer
- Hillclimb and descent
- Freeway (constant speeds)
- City driving
- Twisting roads etc.

These are selected automatically according to resistance to movement, load and accelerator pedal movement speed; depending on the driving situation, various shift characteristics are made available.

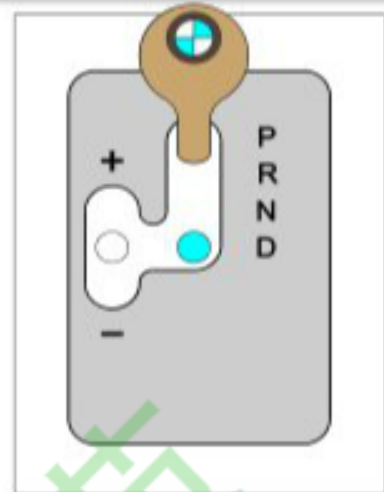
**S program (Sport program)**

The S program is a performance-oriented program, in which the shift characteristics are moved up to higher engine speeds. The program is selected by moving the selector lever across to the left gate plane but without moving it to (+) or (-).

Gears 1 - 6 and 6 - 1 are selected automatically.

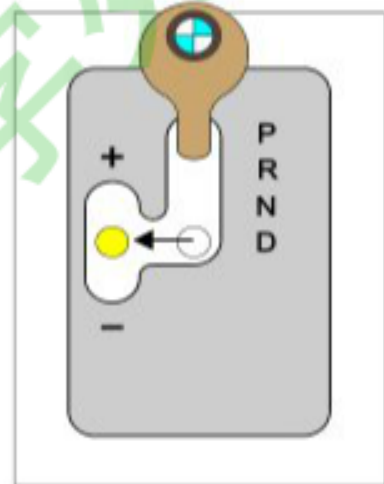
**M program (Tip mode) - manual selection**

The M program a manual selection program activated when the lever is moved to the left gate plane and then to either (+) or (-).

The car can be driven off in gears 1 - 3.

4th gear can be selected manually from app. 10 km/h,

5th gear can be selected manually from app. 35 km/h and

6th gear can be selected manually from app. 45 km/h.

Each movement to (+) causes a one-gear up-shift.

Each movement to (-) causes a one-gear downshift.

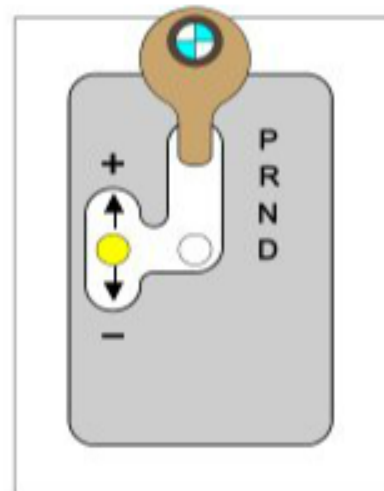

Controls and shift details

2. Electric shift (BMW overview))

The system overview below describes the principal components of the electric shift.

- * Transmission with EGS (Mechatronik)
- * Selector lever on steering column with SZL (switching centre)
- * Instrument cluster
- * Emergency mechanical release



The driver's gear shift requirement is obtained as an electrical signal from the selector lever or the buttons on the multi-functional steering wheel, and transmitted by SZL via the CAN and a redundant serial line to the transmission control unit (EGS). In the transmission the commands are implemented after taking various peripheral conditions into account. The selected gear is displayed on the instrument cluster. The parking lock is controlled electrically and activated when the ignition key is removed.

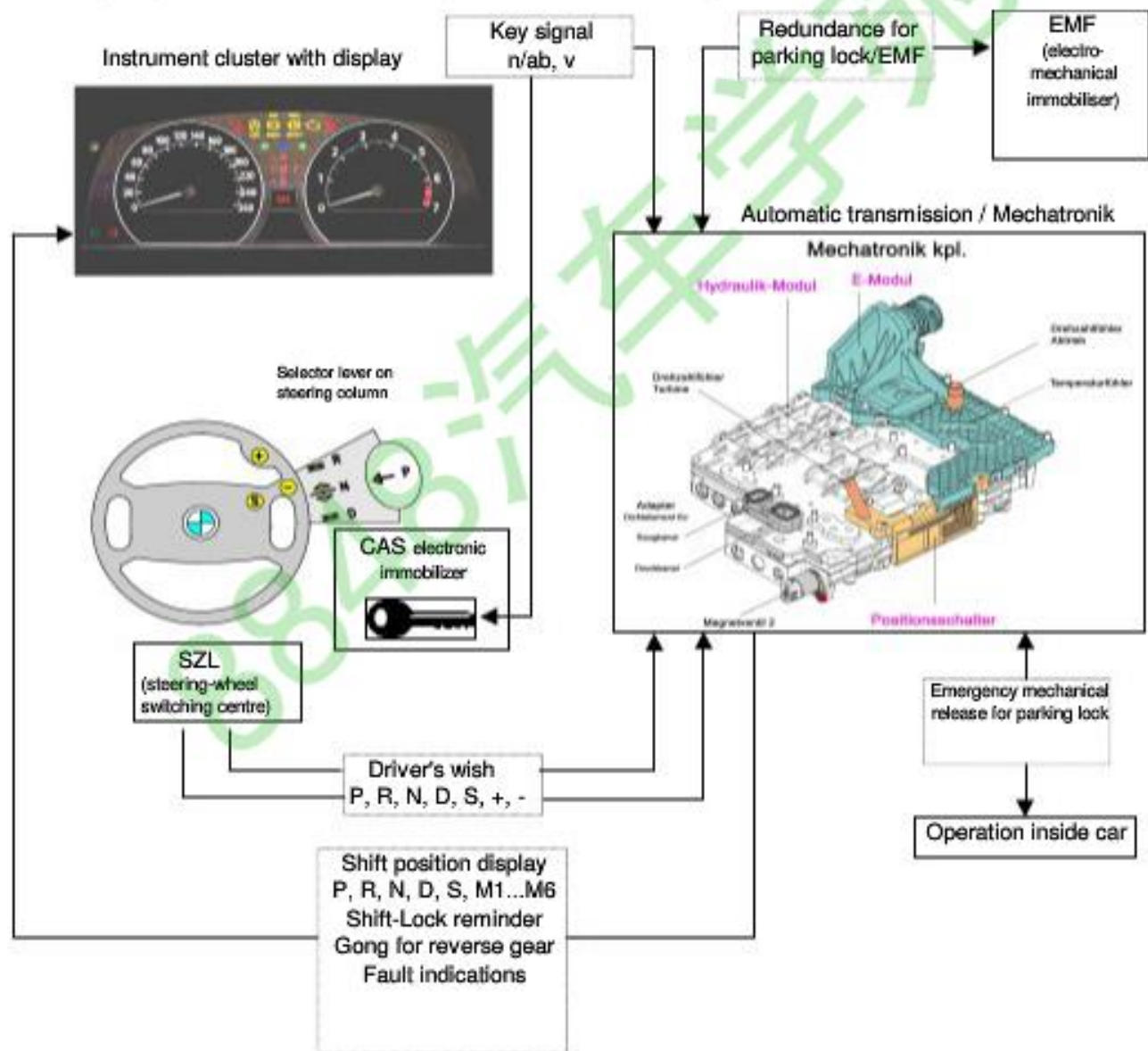

Controls and shift details

3. Electric shift (BMW wiring)

- * Transmission with EGS (Mechatronik)
- * Selector lever on steering column with SZL (steering column switching centre)
- * Car Access System CAS (development of EWS electronic immobiliser)

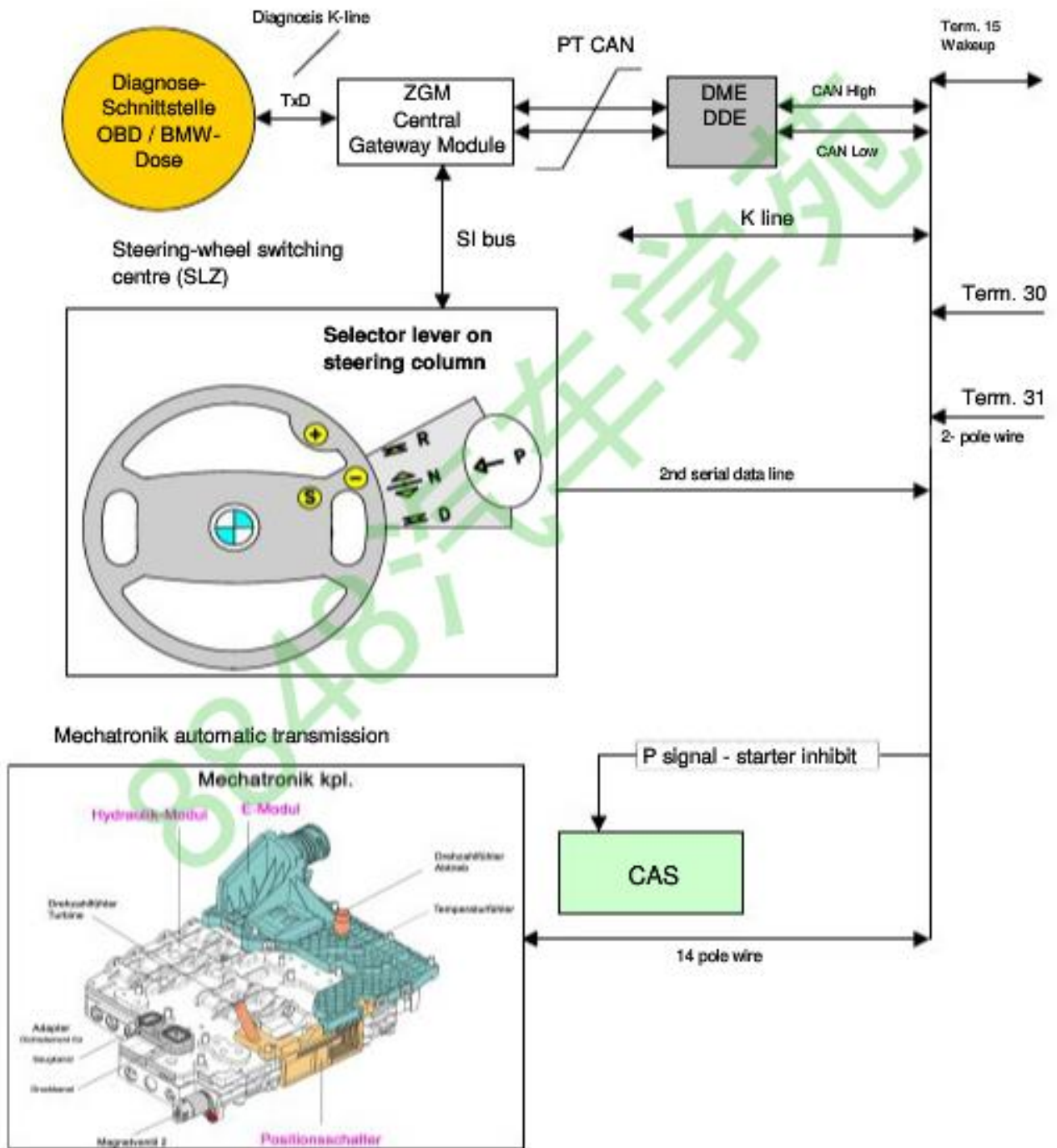

Symbols displayed in regular driving (not emergency run mode)

1. Position "P"- Park

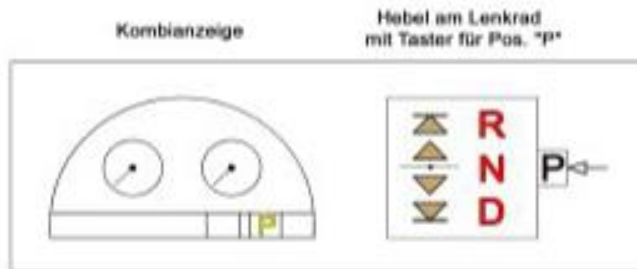

Position P is not part of the actual gear shift gate and is therefore shown on the instrument panel display as a telltale lamp when it is selected.

2. Position "R"- Reverse

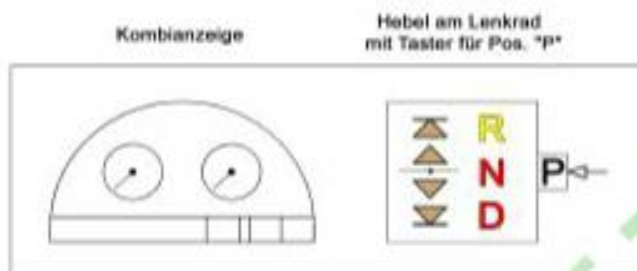

Steering wheel lever moved to R. The R position display is highlighted when reverse gear is engaged. The position display is visible when the ignition is on and if the transmission is not in the P position.

3. Position "N"- Neutral

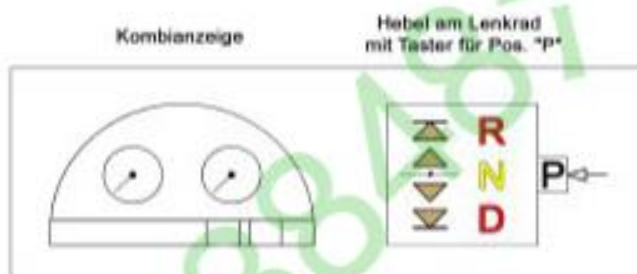

Steering wheel lever moved to N. The N position display is highlighted when neutral is selected. The position display is visible when the ignition is on and if the transmission is not in the P position.

4. Position "D"- Drive (normal forward travel)

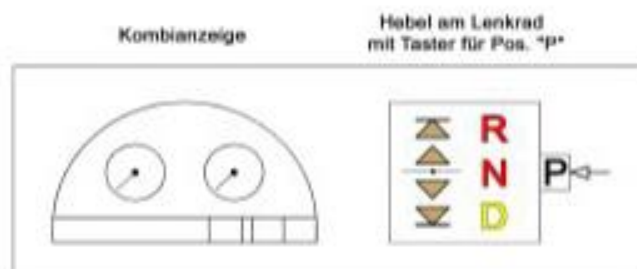

Steering wheel lever moved to D. The D position display is highlighted when normal forward travel is selected. The position display is visible when the ignition is on and if the transmission is not in the P position.

Program selection

5. Position "D", S program (sport)

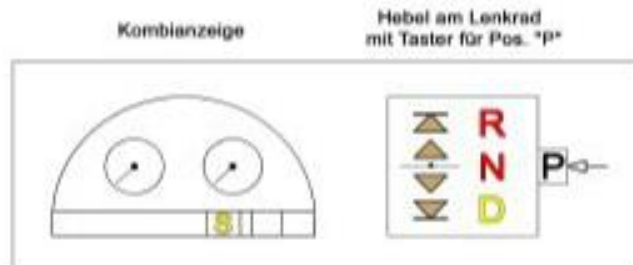

Steering wheel lever moved to D.
The D position display is highlighted when neutral is selected.
The position display is visible when the ignition is on and if the transmission is not in the P position.

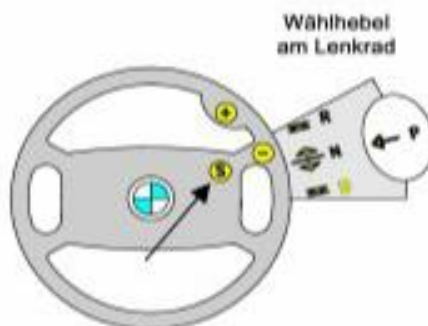

Press the S pushbutton on the multi-functional steering wheel.
The sport program is indicated by an S telltale lamp on the instrument panel.

6. Position "D"- manual selection program (Steptronic mode M1...M6)

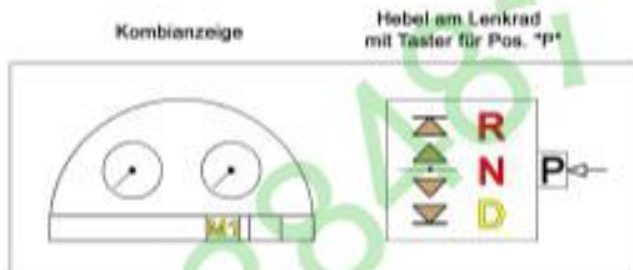

Steering wheel lever moved to D.
The D position display is highlighted when neutral is selected.
The position display is visible when the ignition is on and if the transmission is not in the P position.



Press the (+) or (-) button on the multi-functional steering wheel.
(+) = upshifts, (-) = downshifts

The sport program is shown by the M1...M6 telltale lamps on the instrument panel.

Symbols displayed in emergency run mode

Mechanical-shift transmission - emergency run with power available forwards and CAN communication

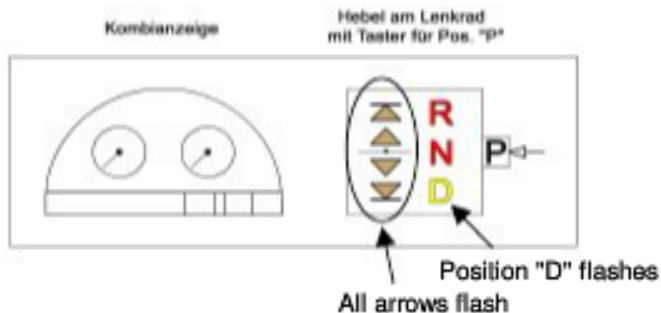

The EGS controls the instrument panel display. All arrows flash. The R, N and D position lights remain on. Position light D flashes alternately with the other position lights.

Mechanical-shift transmission - emergency run in position P with CAN communication

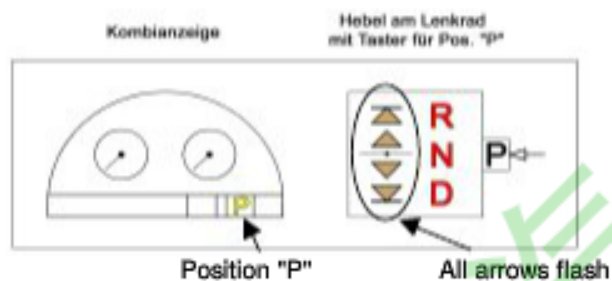

The EGS controls the instrument panel display. All arrows flash. Position lights R, N and D remain on. Position "P" is highlighted.

Mechanical or electronic transmission - emergency run without CAN communication

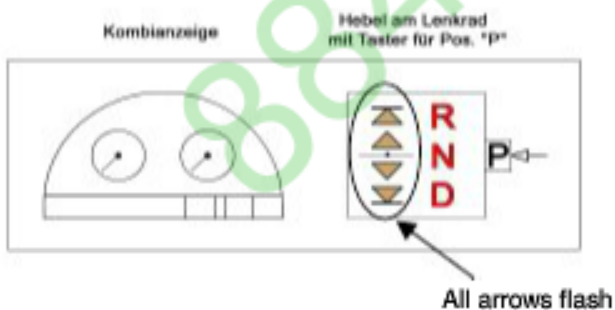

If the EGS fails completely or there is a CAN bus fault, the instrument panel itself controls the display. All arrows flash. Position lights R, N and D remain on. The position display is switched off.

When the ignition is switched on and the engine started, the gate pattern and transmission position "P" or "N" will be displayed. All arrows are shown.

In transmission positions D or R only the arrow for the permissible shift direction is shown instead of position "N".

Description of gears / power flow

Power flow in 1st gear

Shift elements:

Clutch
Brake

A
D

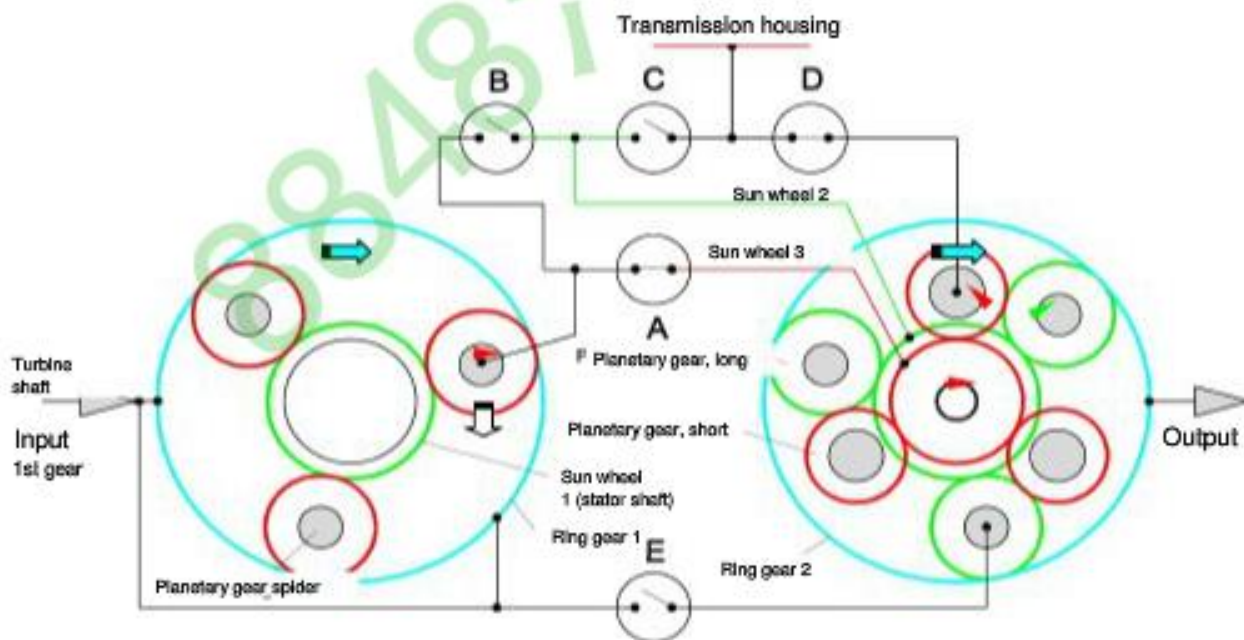
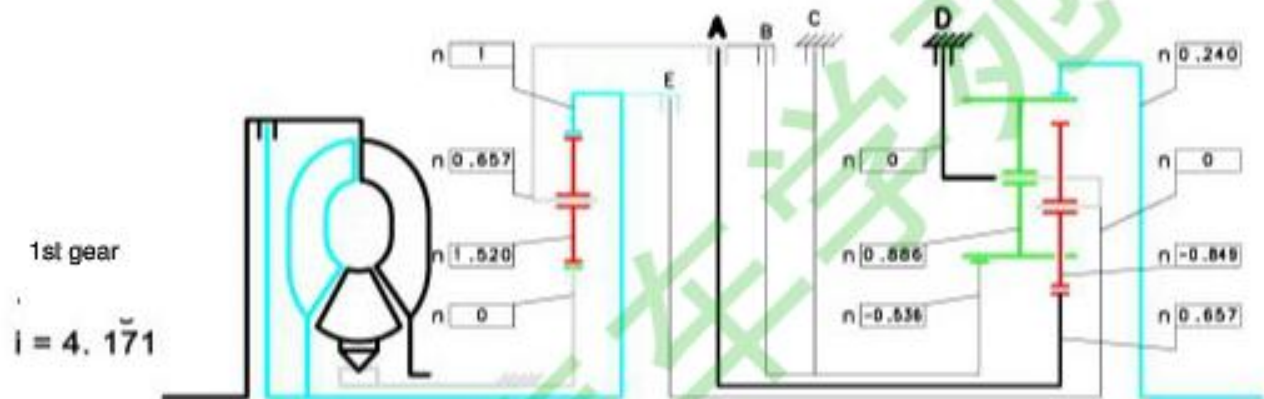

Description of 1st gear power flow

The turbine shaft drives the ring gear of the front, single planetary gear set and the outer plate carrier of clutch "E".

Ring gear 1 drives the planetary gears that roll round fixed sunwheel 1.

This drives planetary gear spider 1 and also the outer plate carrier "A" and the inner plate carrier of clutch "B".

When clutch "A" is engaged, sun wheel 3 in the double planetary gear set is driven; this meshes with the short planetary gears.

The double planetary gear set bears against the transmission housing by way of brake "D". This enables ring gear 2 (output shaft) to be driven in the same direction as the engine via the long planetary gears.

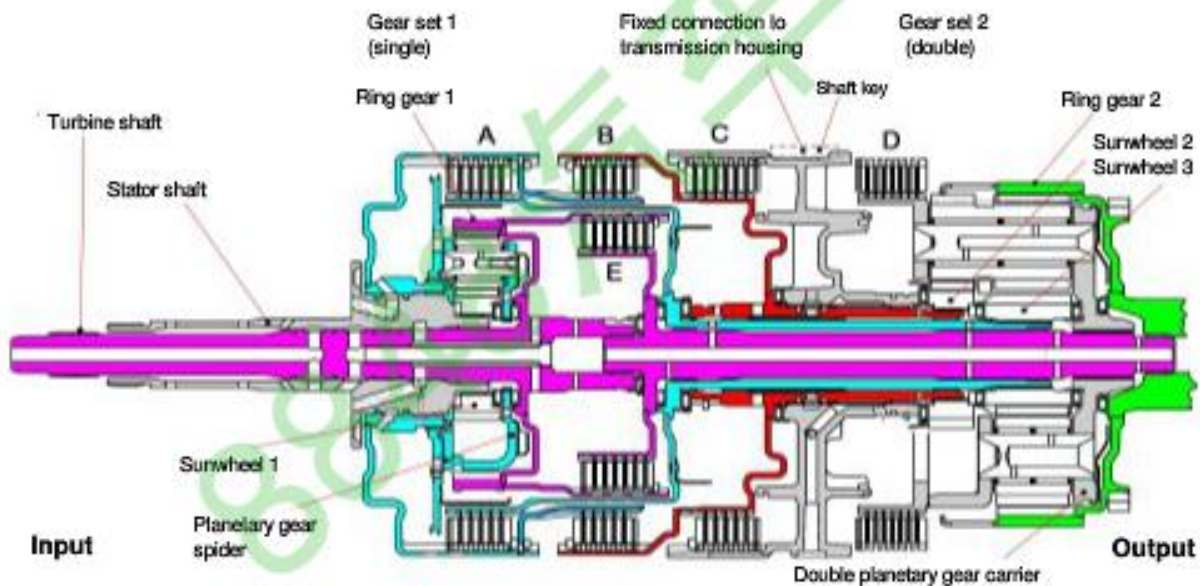

Power flow in 2nd gear

Shift elements: Clutch Brake A C

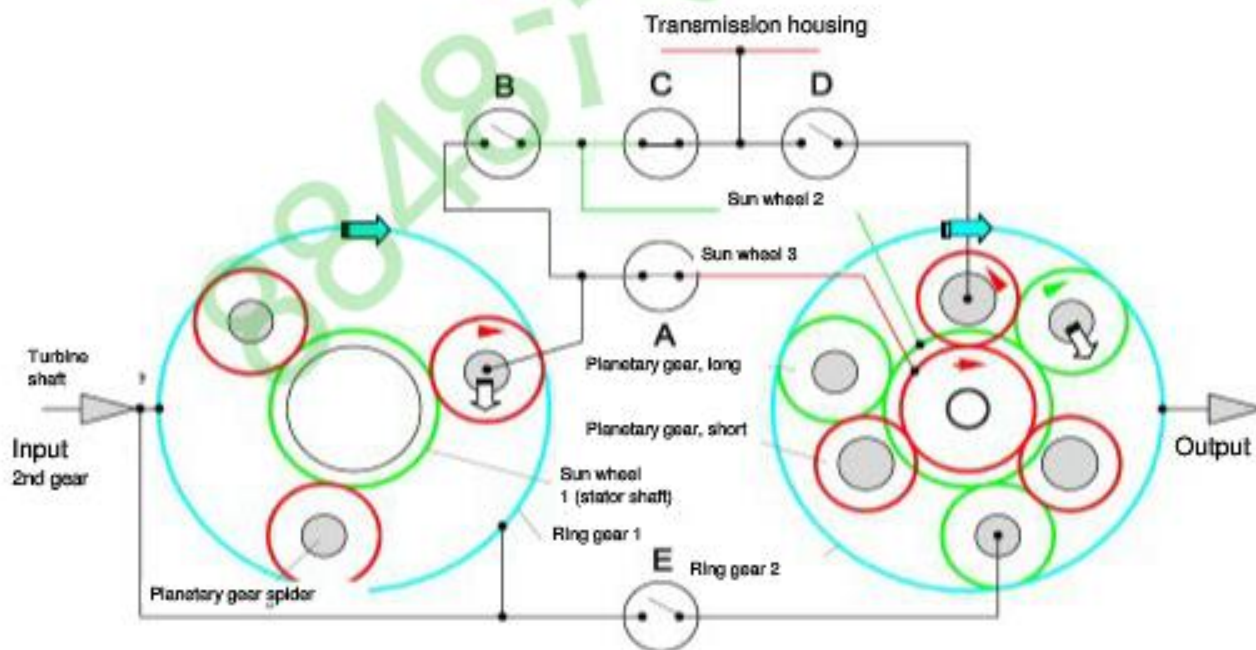
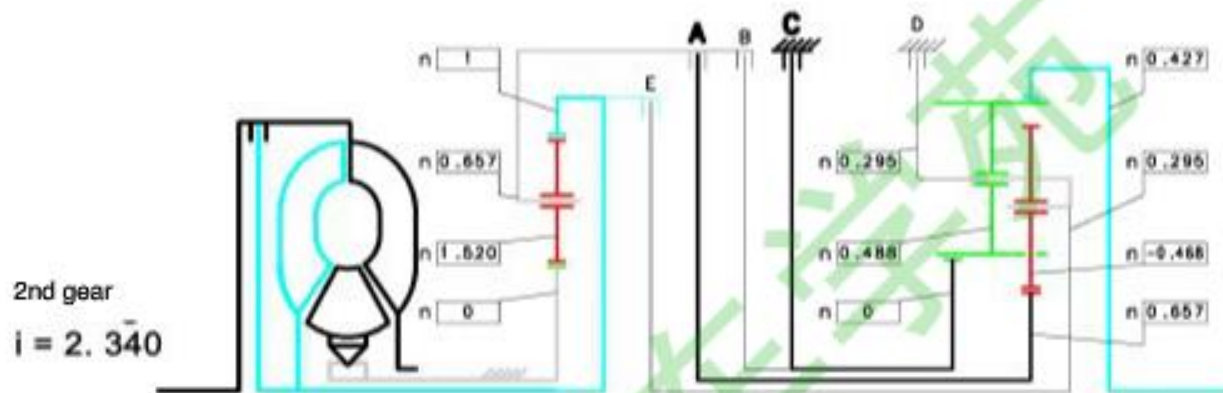

Description of 2nd gear power flow

The turbine shaft drives the ring gear of the front, single planetary gear set and the outer plate carrier of clutch "E".

Ring gear 1 drives the planetary gears that roll round fixed sunwheel 1. This drives planetary gear spider 1 and also outer plate carrier "A" and the inner plate carrier of clutch "B".

When clutch "A" is engaged, sunwheel 3 in the double planetary gear set is driven; this meshes with the short planetary gears.

Sunwheel 2 is locked to the transmission housing by brake "C". The long planetary gears, which are meshed with the short planetary gears, roll round the fixed sunwheel 2 and drive the double planetary gear spider and ring gear 2 in the direction of engine rotation.

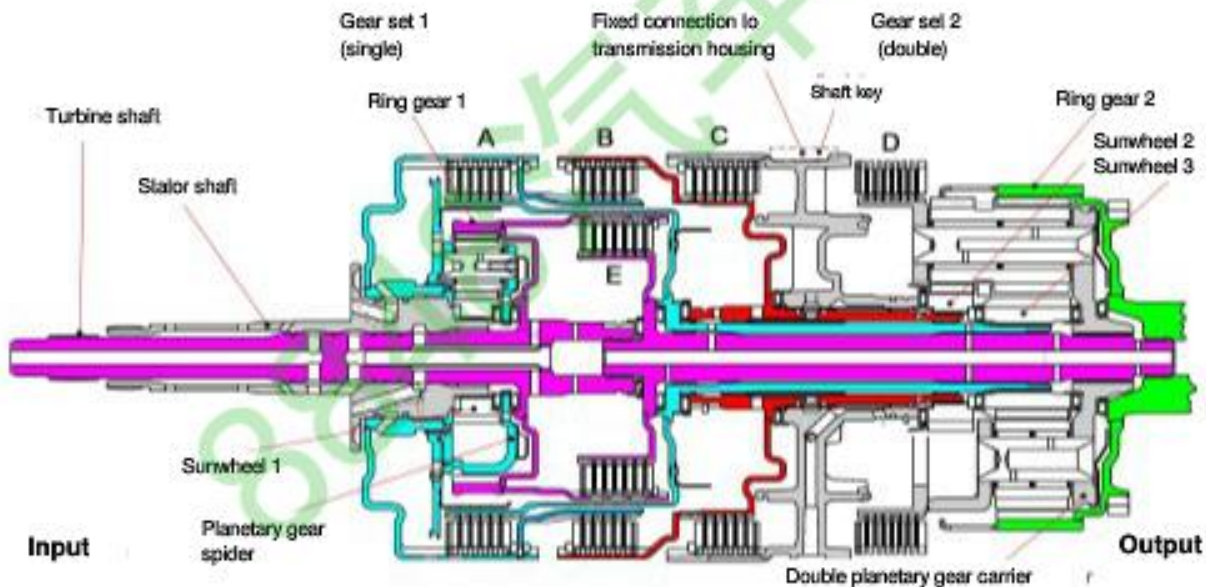

Power flow in 3rd gear

Shift elements: Clutch A B
 Clutch B

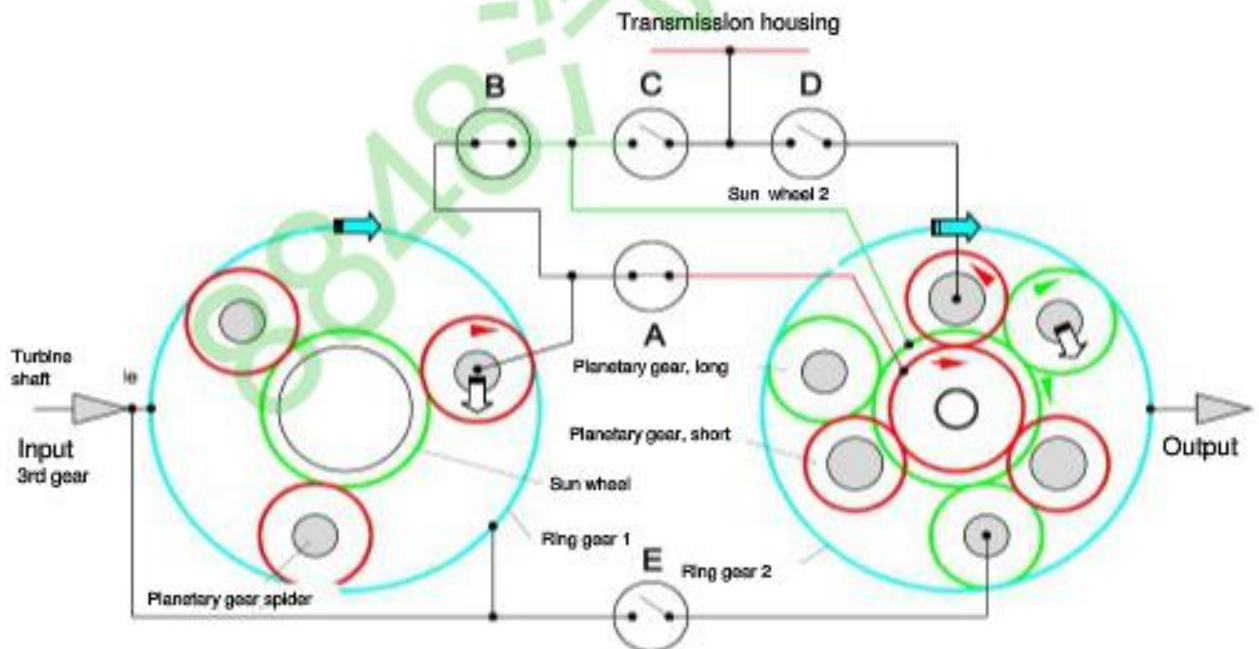
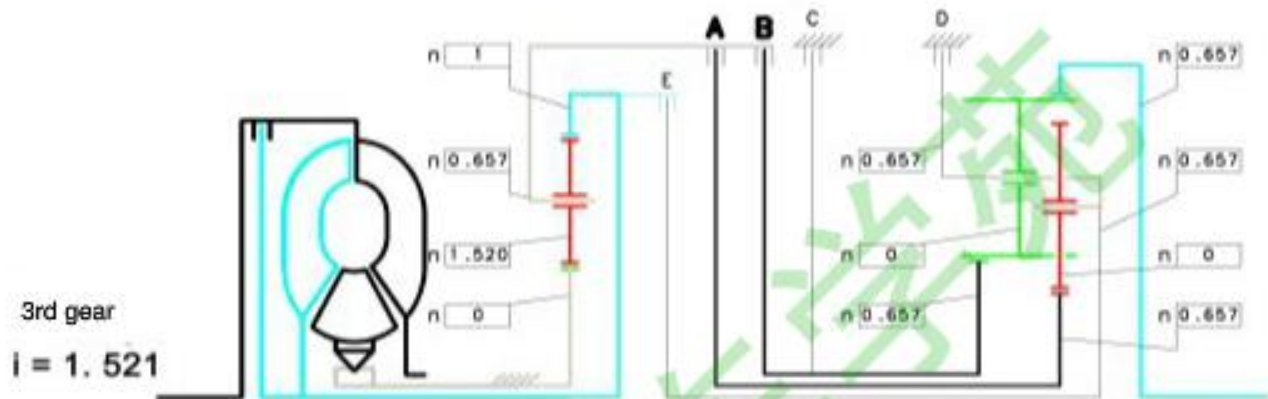

Description of 3rd gear power flow

The turbine shaft drives the ring gear of the front, single planetary gear set and the outer plate carrier of clutch "E".

Ring gear 1 drives the planetary gears, which roll round fixed sunwheel 1. This drives planetary gear spider 1 and at the same time outer plate carrier "A" and the inner plate carrier of clutch "B".

With clutch "A" engaged, sunwheel 3 in the double planetary gear set is driven; this meshes with the short planetary gears.

Sunwheel 2 is driven via engaged clutch "B".

The long planetary gears, which are in engagement with the short ones, can not roll round fixed sunwheel 2 and drive the blocked double planetary gear carrier in the direction of engine rotation.

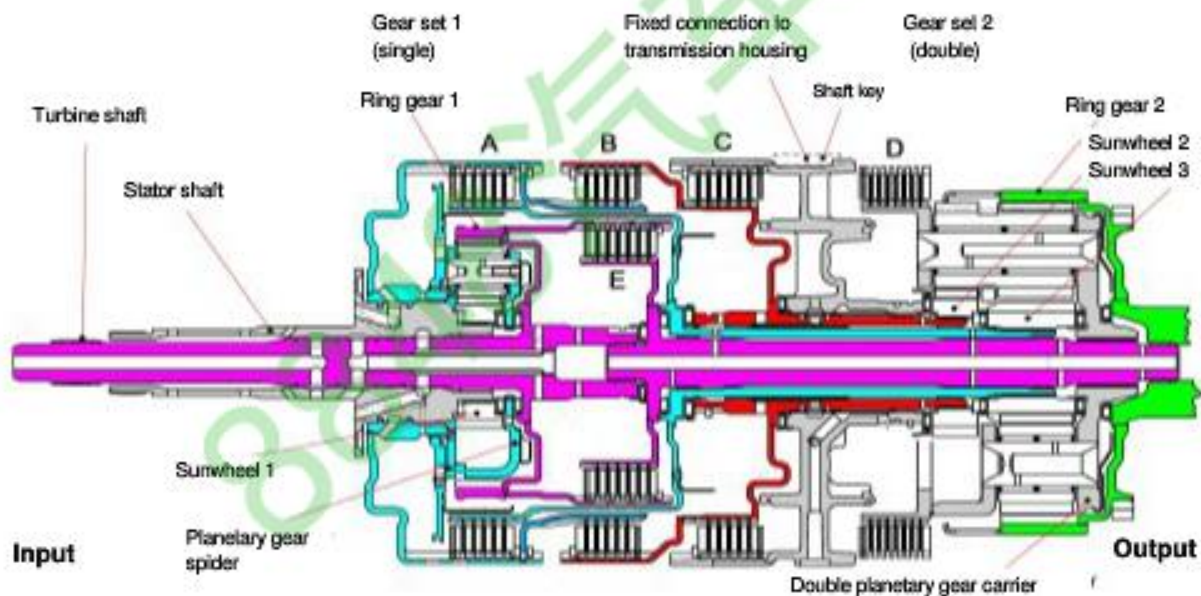

Power flow in 4th gear

Shift elements: Clutch Clutch A E

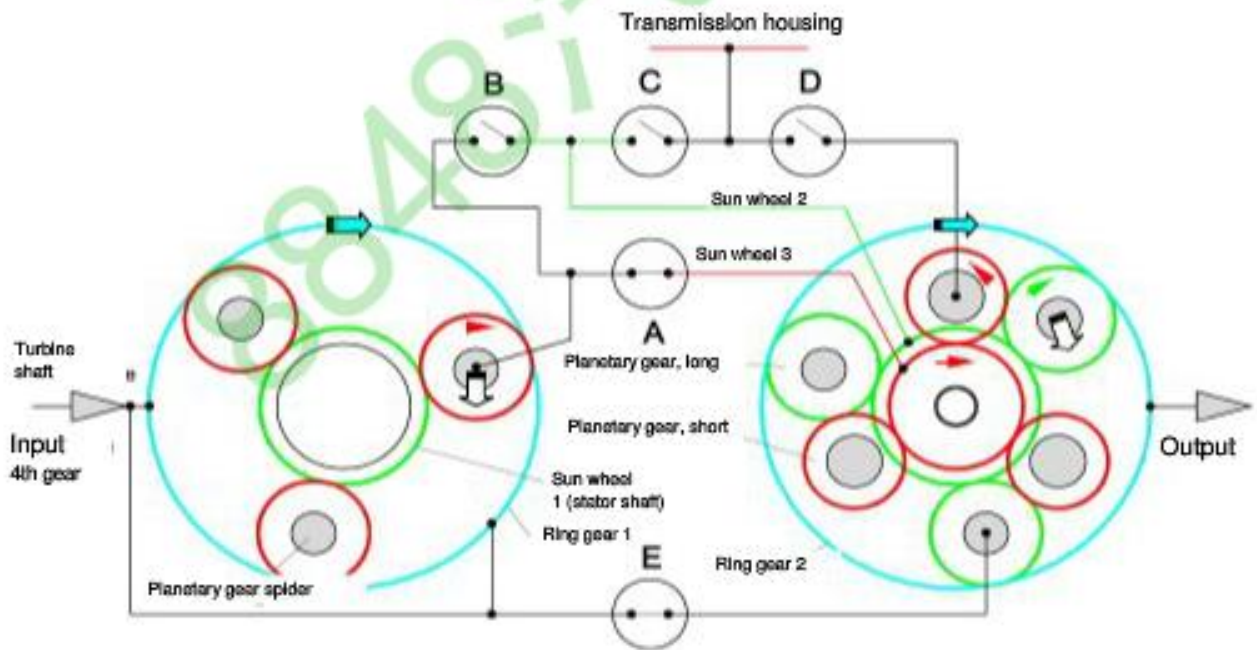
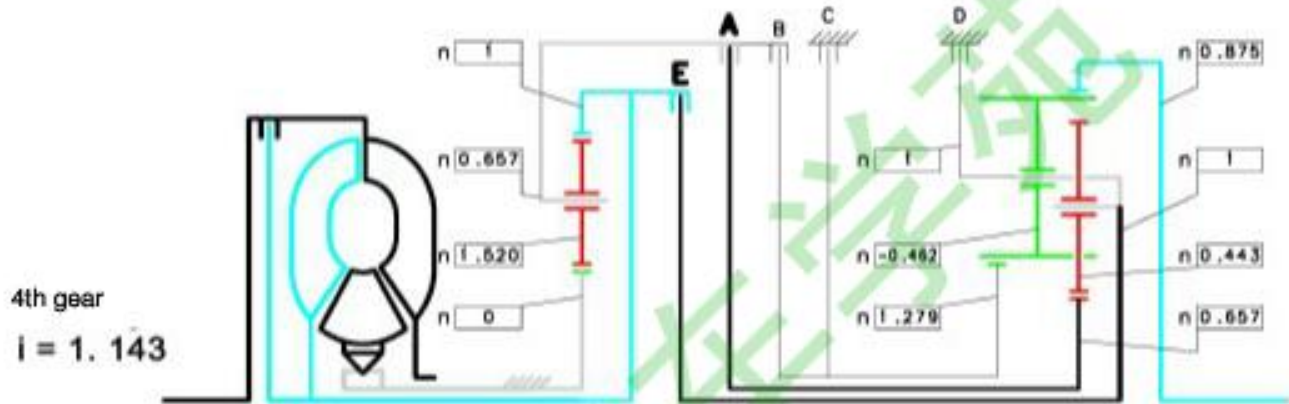

Description of 4th gear power flow

The turbine shaft drives the ring gear of the front, single planetary gear set and the outer plate carrier of clutch "E".

Ring gear 1 drives the planetary gears, which roll round fixed sunwheel 1. This drives planetary gear spider 1 and at the same time outer plate carrier "A" and the inner plate carrier of clutch "B".

With clutch "A" engaged, sunwheel 3 in the double planetary gear set is driven; this is in mesh with the short planetary gears.

The double planetary gear spider is driven via engaged clutch "E".

The long planetary gears, which are in mesh with the short ones, drive (together with the double planetary gear spider) ring gear 2 in the direction of engine rotation.

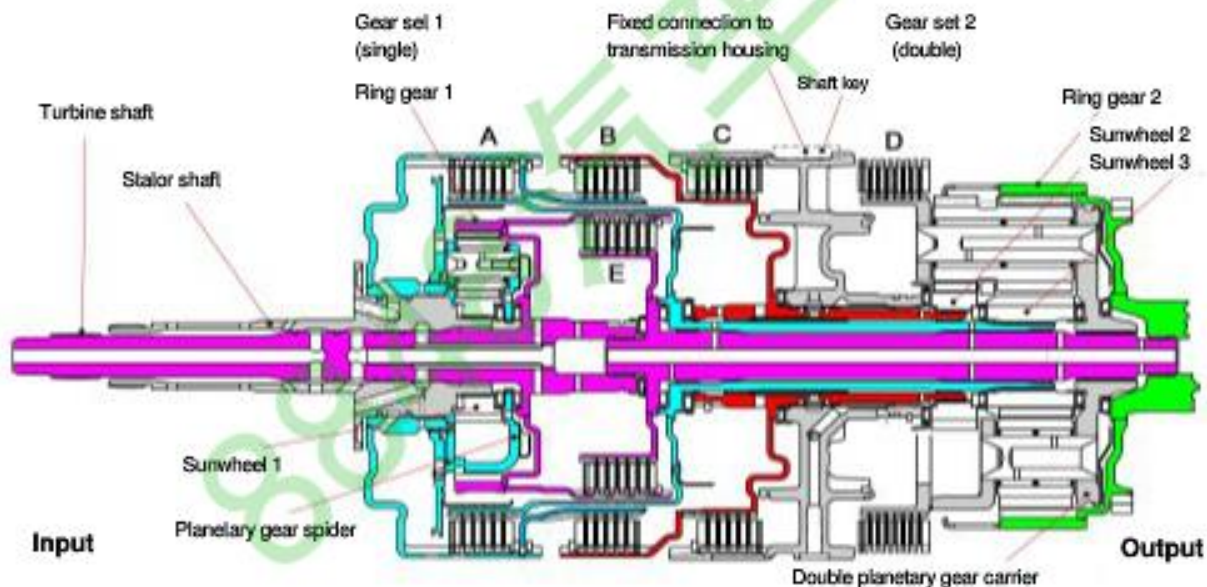

Power flow in 5th gear

Shift elements:

Clutch
Clutch

B
E

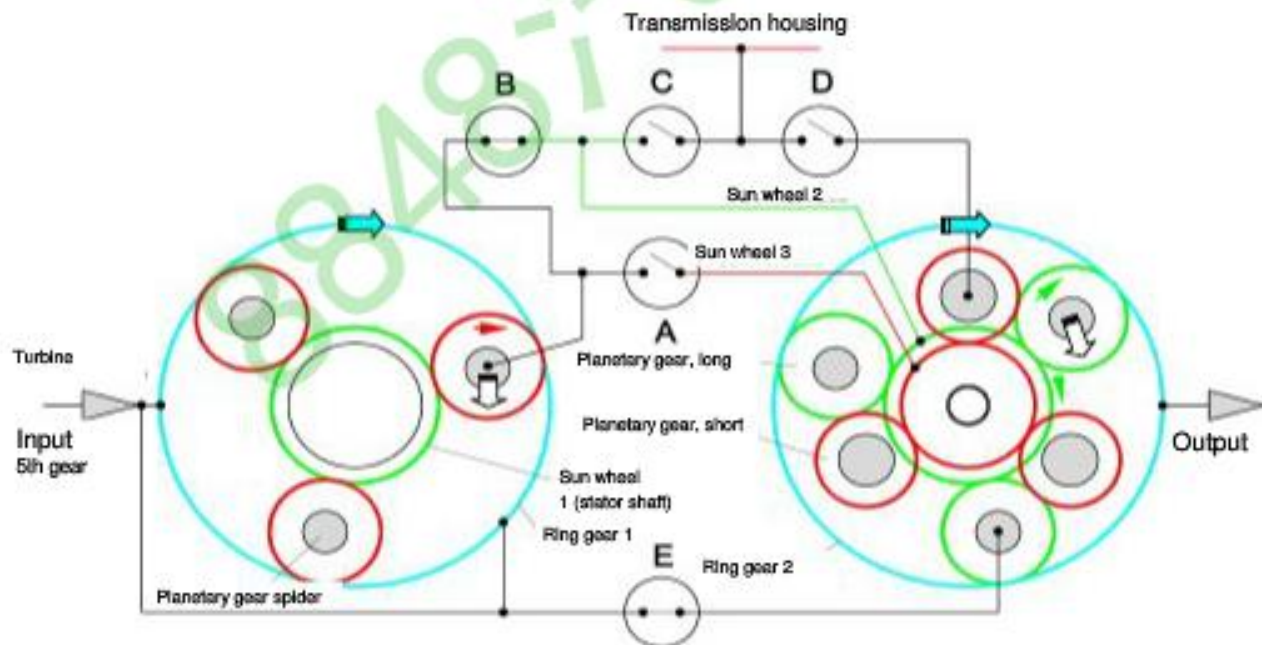
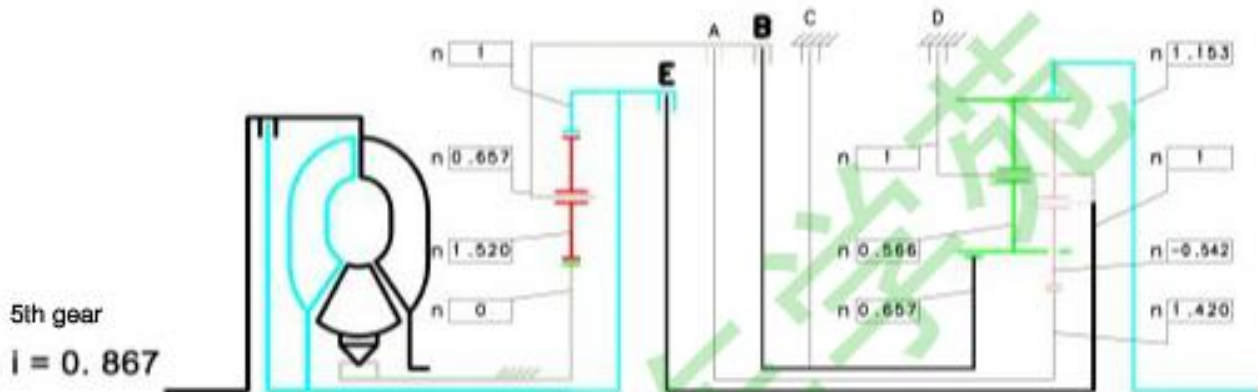

Description of 5th gear power flow

The turbine shaft drives the ring gear of the front, single planetary gear set and the outer plate carrier of clutch "E".

Ring gear 1 drives the planetary gears, which roll around fixed sunwheel 1. This drives planetary gear spider 1 and at the same time outer plate carrier "A" and the inner plate carrier of clutch "B".

With clutch "A" engaged, sunwheel 3 in the double planetary gear set is driven; this is in mesh with the short planetary gears.

The double planetary gear spider is driven via the engaged clutch "E" and sunwheel 2 via engaged clutch "B".

The long planetary gears, which are in mesh with the short ones, drive (jointly with the double planetary gear spider) ring gear in the direction of engine rotation.

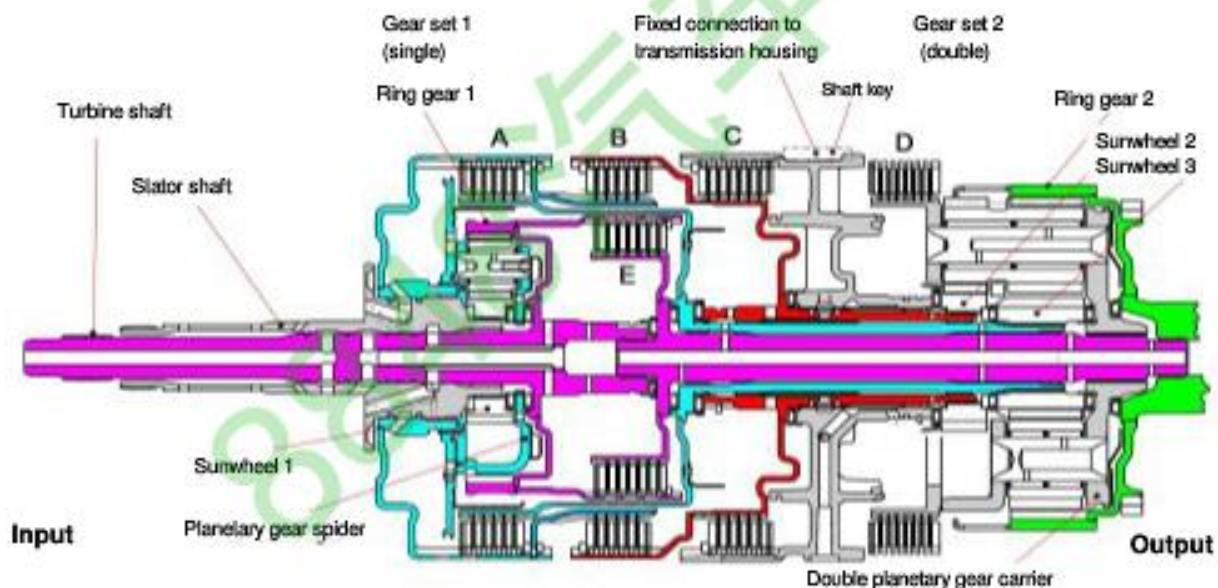

Power flow in 6th gear

Shift elements: Brake Clutch C E

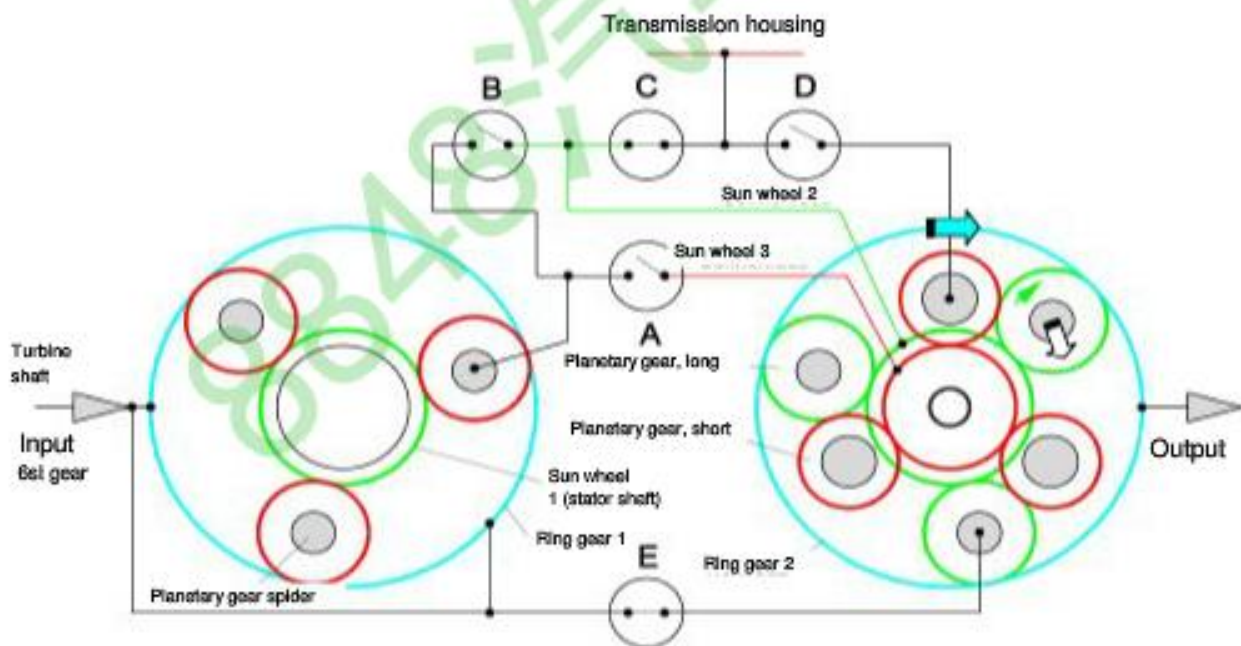
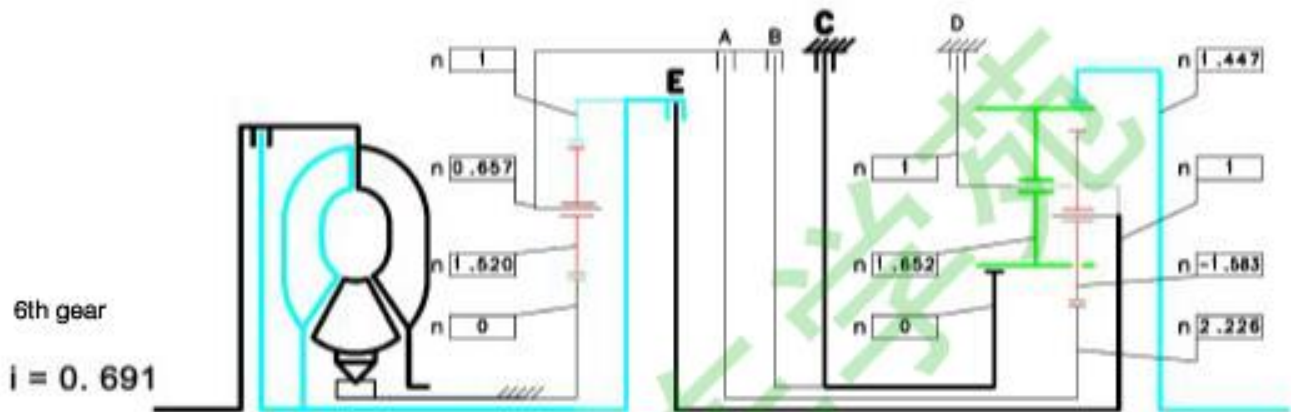

Description of 6th gear power flow

The turbine shaft drives ring gear 1 and the outer plate carrier of clutch "E".

Clutches "A" and "B" are released, so that the front planetary gear set has no effect.

Sunwheel 2 is locked to the transmission housing via brake "C", which is applied.

The double planetary gear spider is driven via engaged clutch "E", so that the long planetary gears roll round fixed sunwheel 2 and ring gear 2 is driven in the direction of engine rotation.

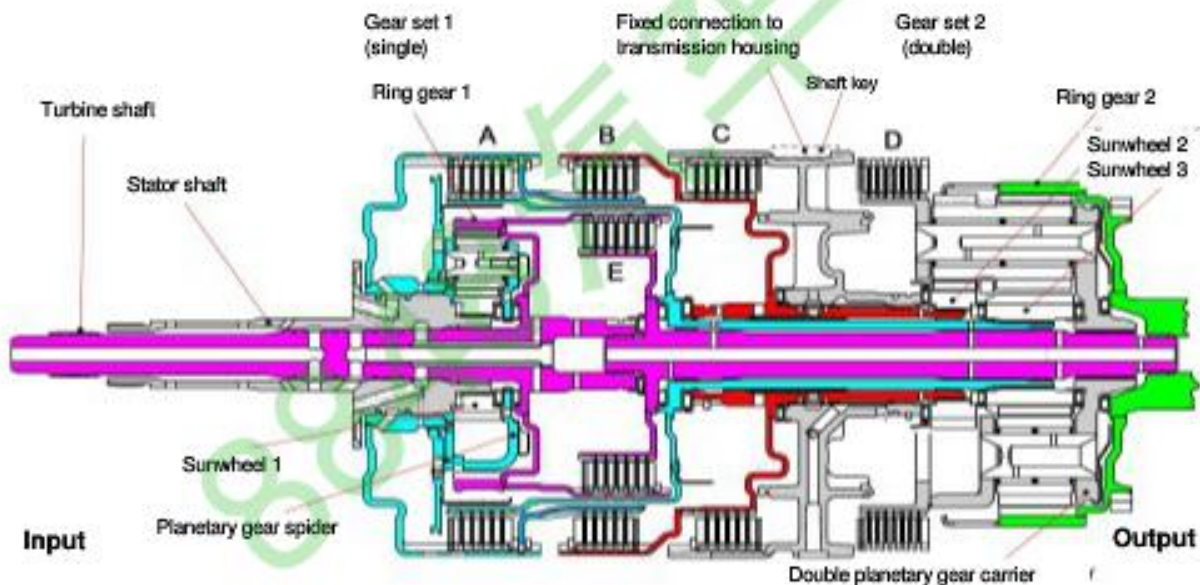

Power flow in Reverse

Shift elements: Clutch B
 Brake D

