



Fuel Filter 19.25.02

Removal  **WARNING:**
PLACE THE VEHICLE IN A QUARANTINED AREA AND ARRANGE 'NO SMOKING/PETROL FUMES' SIGNS ABOUT THE VEHICLE.

 **WARNING:**
BEFORE ANY WORK IS CARRIED OUT ON THE FUEL SYSTEM, GROUND THE VEHICLE TO EARTH AND MAINTAIN THE GROUND CONNECTION UNTIL THE WORK IS COMPLETE.

 **WARNING:**
DO NOT SMOKE OR CARRY LIGHTED TOBACCO OR OPEN FLAME OF ANY TYPE WHEN WORKING ON OR NEAR ANY FUEL RELATED COMPONENTS. HIGHLY FLAMMABLE VAPORS ARE ALWAYS PRESENT AND MAY IGNITE. FAILURE TO FOLLOW THESE INSTRUCTIONS MAY RESULT IN PERSONAL INJURY.

 **WARNING:**
THE FUEL SYSTEM REMAINS PRESSURIZED FOR A LONG TIME AFTER THE IGNITION IS SWITCHED OFF. THE FUEL PRESSURE MUST BE RELIEVED BEFORE ATTEMPTING ANY REPAIRS. FAILURE TO FOLLOW THESE INSTRUCTIONS MAY RESULT IN PERSONAL INJURY.

 **WARNING:**
AFTER CARRYING OUT REPAIRS, THE FUEL SYSTEM MUST BE CHECKED VISUALLY FOR LEAKS. FAILURE TO FOLLOW THESE INSTRUCTIONS MAY RESULT IN PERSONAL INJURY.

 **WARNING:**
THIS PROCEDURE INVOLVES FUEL HANDLING. BE PREPARED FOR FUEL SPILLAGE AT ALL TIMES AND ALWAYS OBSERVE FUEL HANDLING PRECAUTIONS. FAILURE TO FOLLOW THESE INSTRUCTIONS MAY RESULT IN PERSONAL INJURY.

 **WARNING:**
IF TAKEN INTERNALLY DO NOT INDUCE VOMITING, SEEK IMMEDIATE MEDICAL ATTENTION. FAILURE TO FOLLOW THESE INSTRUCTIONS MAY RESULT IN PERSONAL INJURY.

 **WARNING:**
IF FUEL CONTACTS THE EYES, FLUSH THE EYES WITH COLD WATER OR EYEWASH SOLUTION AND SEEK MEDICAL ATTENTION.

 **WARNING:**
WASH HANDS THOROUGHLY AFTER HANDLING, AS PROLONGED CONTACT MAY CAUSE IRRITATION. SHOULD IRRITATION DEVELOP, SEEK MEDICAL ATTENTION.

1. Release the fuel pressure. <<310-00>>
2. Raise and support the vehicle. For additional information, refer to <<100-02>>.

2004 XK RANGE - Fuel Tank and Lines - 310-01

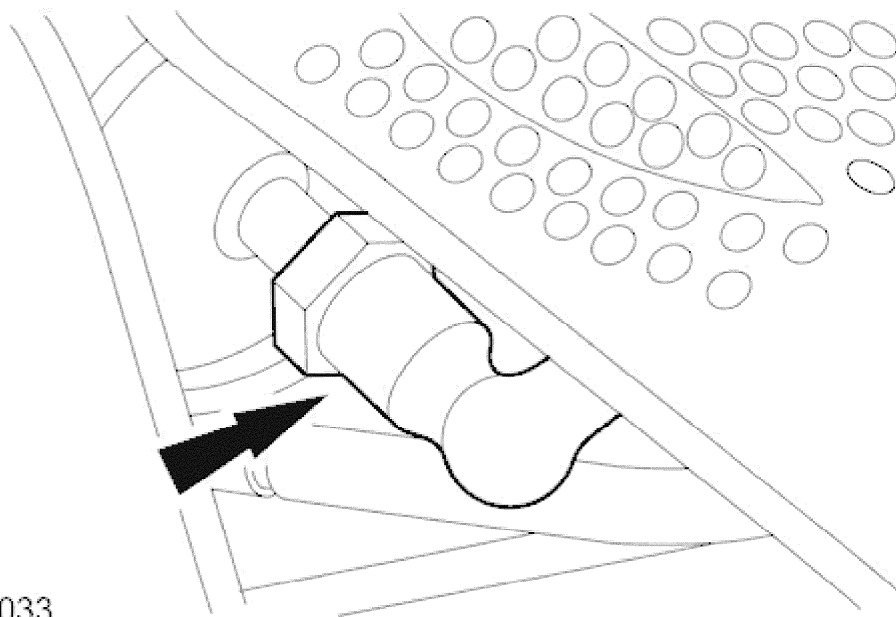

E38033

3. Disconnect the fuel filter to fuel injection supply manifold fuel line. <<310-00>>

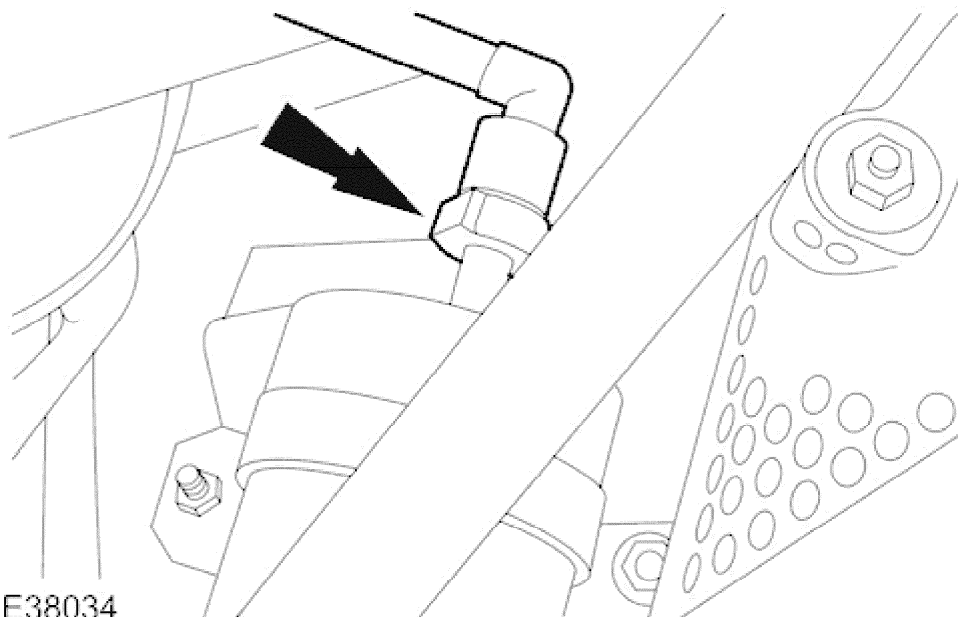

E38034

4. Disconnect the fuel tank to fuel filter fuel line. <<310-00>>

2004 XK RANGE - Fuel Tank and Lines - 310-01

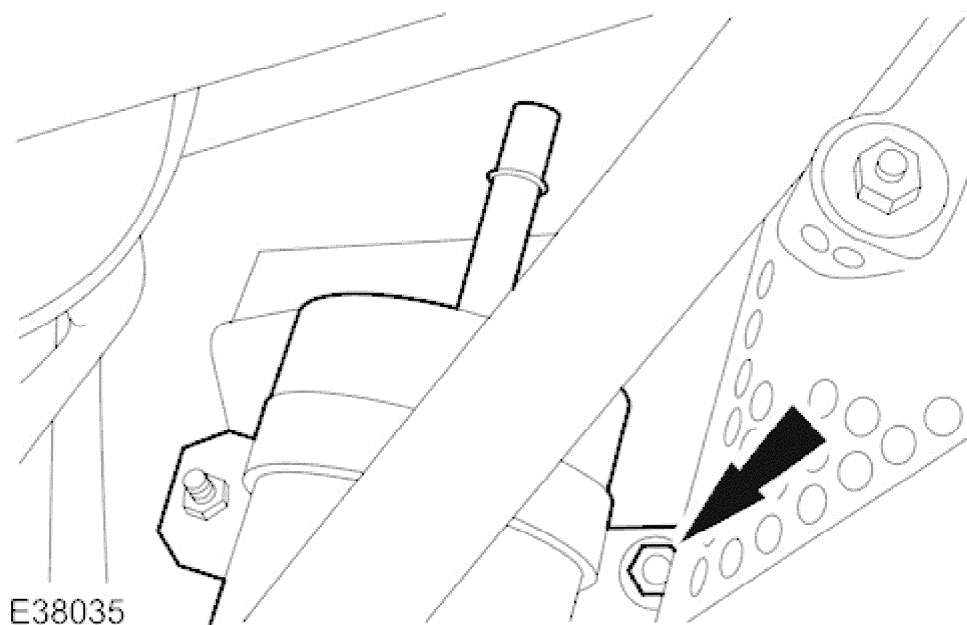

5. Remove the fuel filter and bracket.

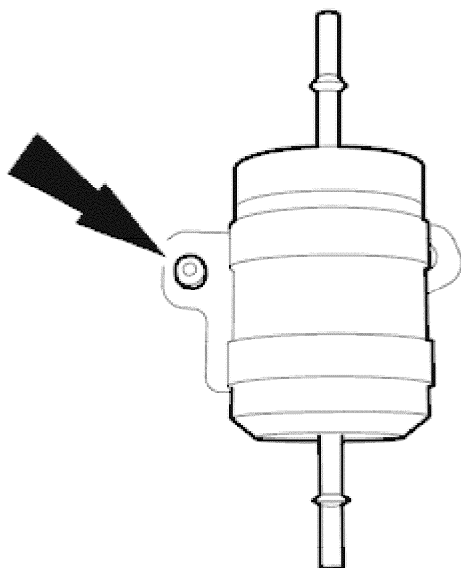

6. **NOTE:**

Observe the direction of the fuel filter fuel flow arrow.

Remove the fuel filter.

Installation

2004 XK RANGE - Fuel Tank and Lines - 310-01

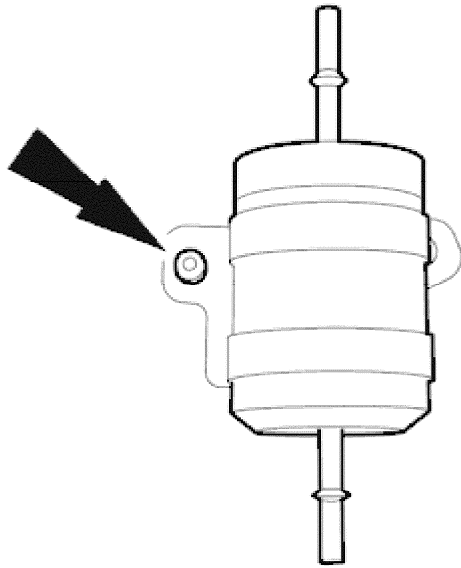

E38036

1. **NOTE:**

Make sure the fuel filter fuel flow arrow is correctly positioned.

To install, reverse the removal procedure.

- Tighten to 4 Nm.

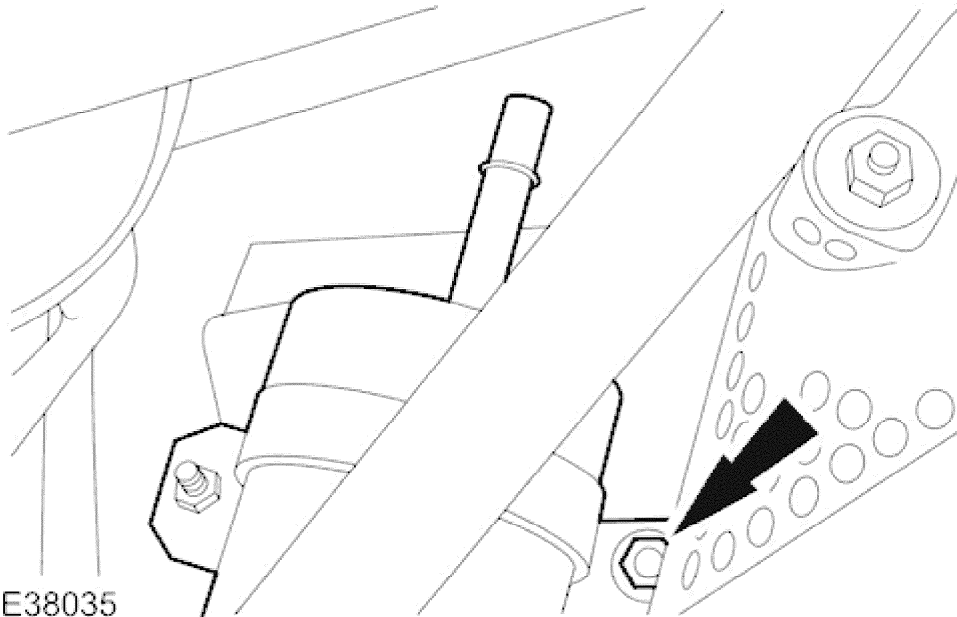

E38035

2. Tighten to 4 Nm.