

1997 XK RANGE - Seating - 501-10

Front Seat Recliner Motor 86.75.04

Removal

1. Remove battery cover and disconnect ground cable from battery terminal. Refer to <<86.15.19>>.
2. Remove front seat back finisher. Refer to <<76.70.03>>.

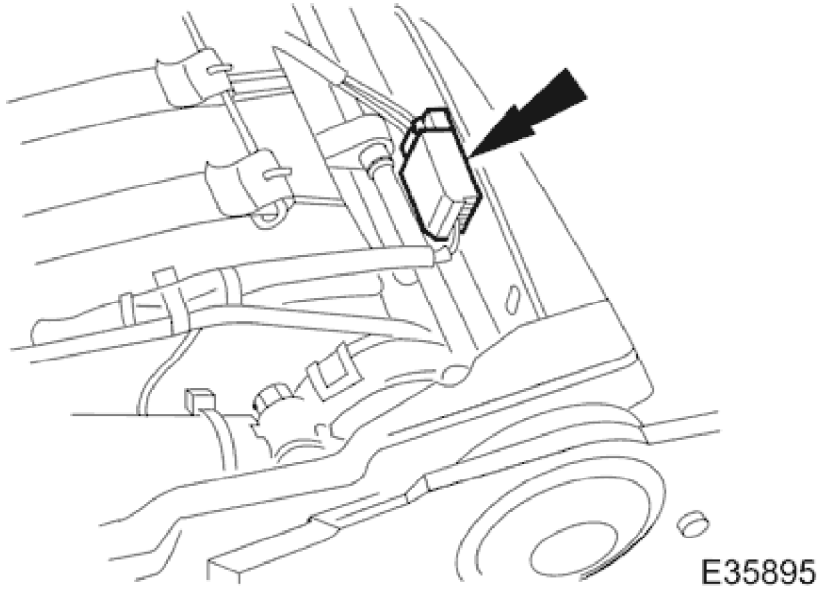

3. Detach motor harness multiplug from mounting.

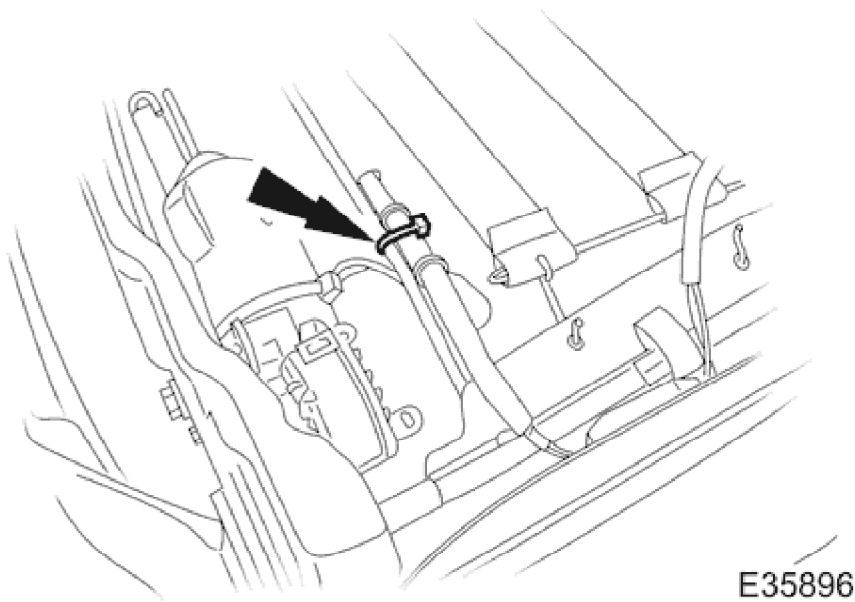

4. Disconnect harness multiplug from motor and sever and remove tiestrap securing harness to seat frame.

1997 XK RANGE - Seating - 501-10

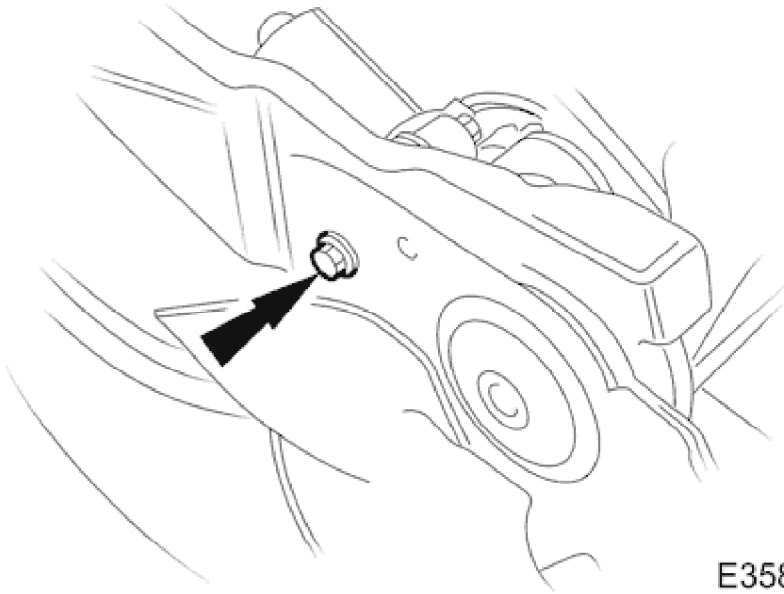

E35897

5. Remove bolt securing motor mounting bracket to seat frame.

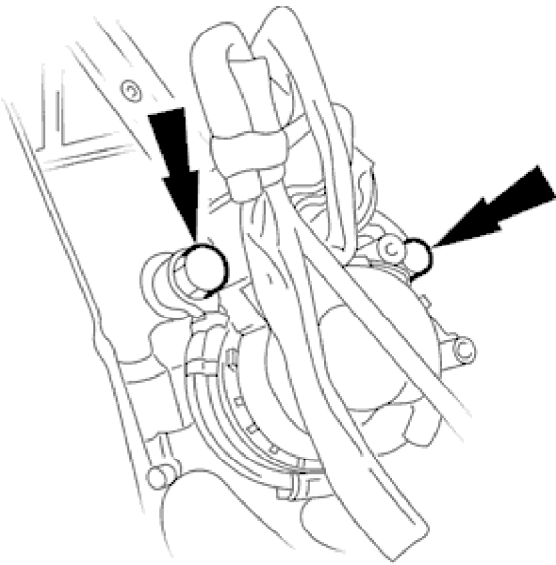

E35898

6. Position motor and mounting bracket for access and remove the two motor to bracket securing bolts.

Installation

1. Position motor on mounting bracket and install securing bolts.
2. Position motor and bracket assembly on seat frame and install securing bolt.
3. Using new tiestrap, secure motor harness to seat frame.

1997 XK RANGE - Seating - 501-10

4. Connect harness multiplug to motor and install seat multiplug on mounting.
5. Install seat back finisher. Refer to <<**76.70.03**>>.
6. Connect ground cable to battery terminal and install battery cover. Refer to <<**86.15.15**>>.