



CUSTOMER INSTRUCTIONS  
 INSTRUCTIONS CLIENT  
 ANLEITUNG FÜR DEN KUNDEN  
 INSTRUCCIONES PARA EL CLIENTE  
 ISTRUZIONI PER IL CLIENTE  
 カスタム インストラクション

XK

Wind Deflector,  
 Déflecteur, Windabweiser,  
 Deflector, Deflettore,  
 ウィンド ディフレクタ

Installation  
 Pose  
 Einbau  
 Montaje  
 Montaggio  
 取り付け

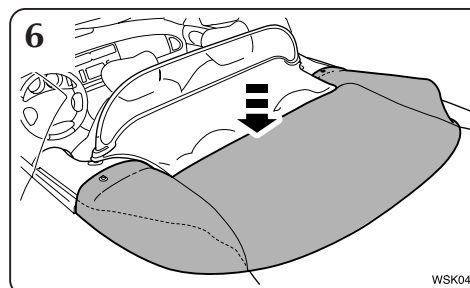
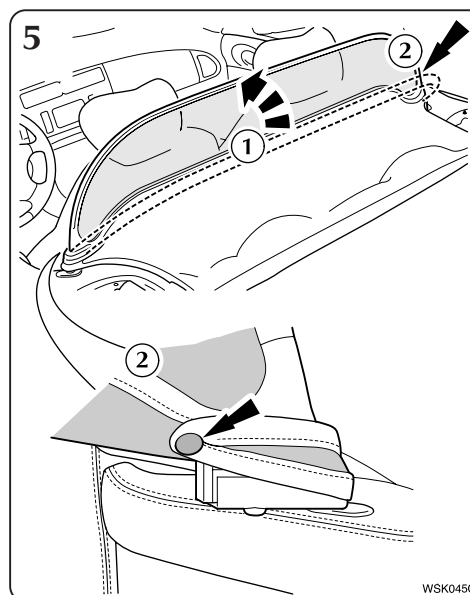
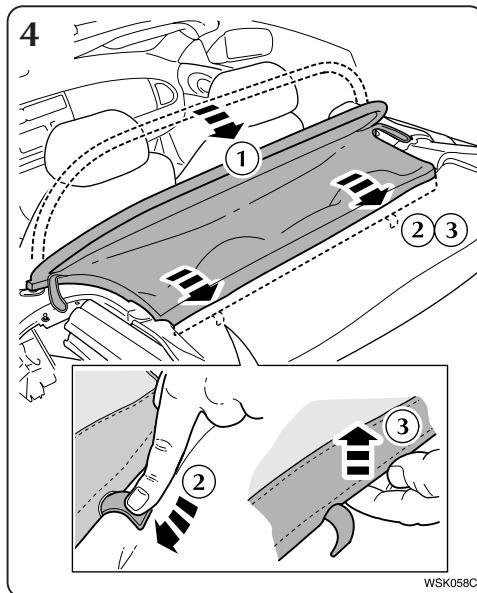
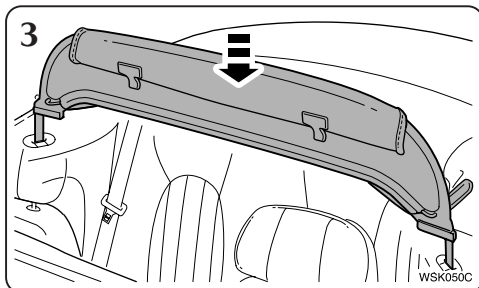
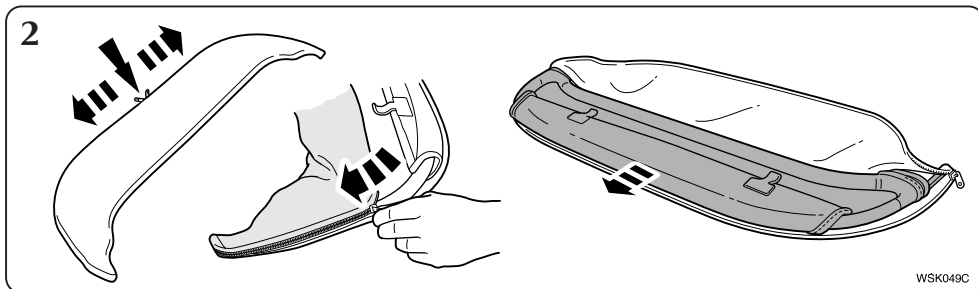
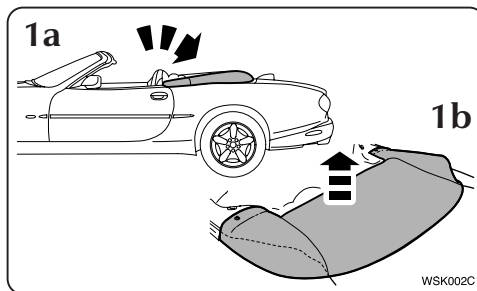

Notes: Hinweise: Note: Nota: 注:

5. Ensure cover is taut across vehicle.
5. Veiller à ce que la housse soit tendue sur toute la largeur du véhicule.
5. Korrekten Sitz der Abdeckung über Karosserieöffnung sicherstellen.
5. Asegúrese de que la cubierta quede correctamente tensada en el vehículo.
5. Accertarsi che la copertura sia tesa lungo il veicolo.
5. 車両全体でカバーがきちんとしていることを確認します。

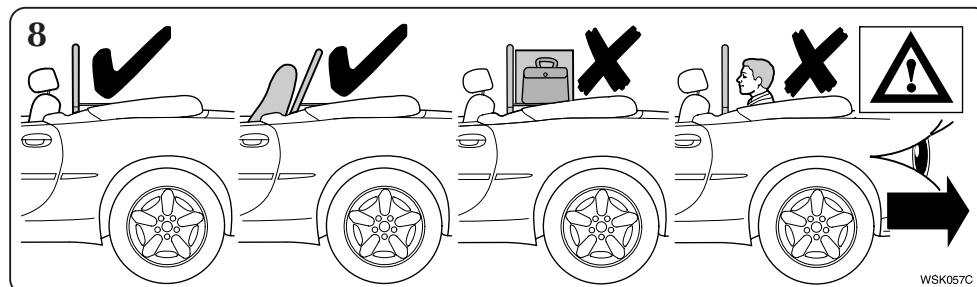
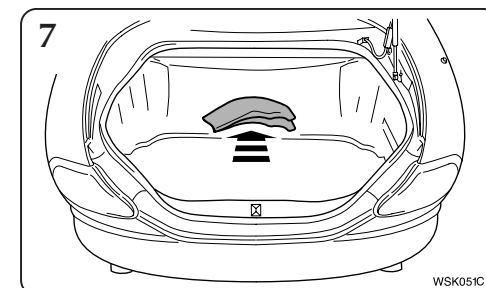



Take care when adjusting seat/headrest position with Wind Deflector installed to prevent contact.

Procéder avec précaution lors du réglage de la position du siège/de l'appui-tête afin d'éviter tout contact avec le déflecteur lorsque celui-ci est posé.

Wird bei aufgestelltem Windabweiser der Sitz bzw. die Kopfstütze eingestellt, vorsichtig vorgehen, um Berührung zu vermeiden.

Quando el vehículo vaya equipado con un deflector, tenga cuidado al ajustar la posición del asiento/reposacabezas para evitar que rocen.

Durante la regolazione della posizione del sedile/poggiatesta, fare attenzione a non venire a contatto con il deflettore montato.

ウィンドディフレクタを取り付けた状態でシート/ヘッドレストの位置を調整する際には、接触しないように注意します。

Wind Deflector must not be used for load carrying or anything other than it's designed/specified purpose.

Ne pas utiliser le déflecteur pour le transport d'une charge ou à des fins autres que celles spécifiées ou pour lesquelles il a été conçu.

Windabweiser nur wie spezifiziert verwenden und keinesfalls Lasten darauf ablegen.

No se debe utilizar el deflector para soportar ninguna carga ni para cualquier otro fin que no sea el de su función específica.

Non utilizzare il deflettore per sorreggere carico o per qualsiasi altra funzione al di fuori di quelle originariamente previste.

ウィンドディフレクタは、荷物の運搬など本来の目的とは異なることのために使用してはいけません。

**Removal**  
**Demontage**  
**Smontaggio**  
**Desmontaje**  
**取り外し**

