

# XK8 Range 2001 Model Year Electrical Guide

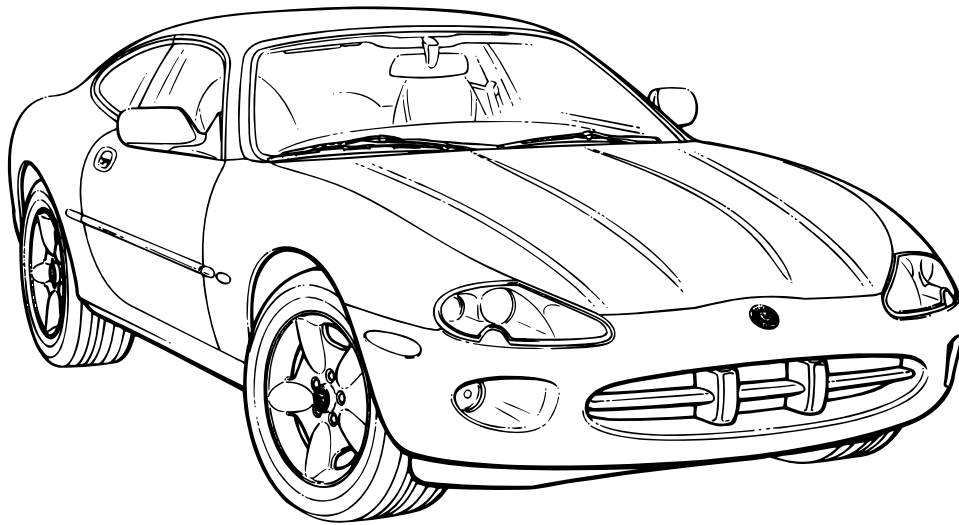

XK8 Range 2001

Publication number s,2001,XK8

Date of Issue: September 2000

© 2000Jaguar Cars

PRINTED IN USA

All rights reserved. All material contained herein is based on the latest information available at the time of publication. The right is reserved to make changes at any time without notice.





## Electrical Guide Format

This Electrical Guide is made up of two major sections. The first section, at the front of the book, provides general information for and about the use of the book, and information and illustrations to aid in the understanding of the XK8 electrical / electronic systems, as well as the location and identification of components.

The second section includes the Figures, which are the basis of the book. Each Figure is identified by a Figure Number (i.e. Fig. 01.1) and Title, and is accompanied by a page of data containing information specific to that Figure.

It is recommended that the user read through the front section of the book to develop a familiarity with the layout of the book and with the system of symbols and abbreviations used. The Table of Contents on the following pages should help to guide the user.

## Standard Abbreviations

The following abbreviations are used throughout this Electrical Guide:

ACP	Audio Control Protocol Network
B+	Battery Voltage
CAN	Controller Area Network
COUPE	Coupe Vehicles
CONV.	Convertible Vehicles
DI	Direction Indicator
LH	Left-Hand
LHD	Left-Hand Drive
N/A	Normally Aspirated
NAS	North American Specification
RH	Right-Hand
RHD	Right-Hand Drive
ROW	Rest of World
SC	Supercharged
SCP	Standard Corporate Protocol Network
VIN	Vehicle Identification Number

## Vehicle Identification Numbers (VIN)

VIN ranges are presented throughout the book in the following manner:

➔ VIN 123456 indicates "up to VIN 123456"; VIN 123456 ➔ indicates "from VIN 123456 on".

## XK8 Electrical System

The vehicle electrical system is a ground side switched system. The ignition switch switches ground circuits on / off to complete system circuits and apply power. Circuits that require ignition switch position control are supplied with "ignition switched grounds". Both power grounds (high current consumers) and logic grounds (electronic switching circuits) are used throughout the system.

Three data networks are employed in the vehicle: a high speed Controller Area Network (CAN) for the engine, drive train and related systems, a Standard Corporate Protocol network (SCP) for the body systems, and an Audio Control Protocol network (ACP) for certain In-Car Entertainment and Telephone functions. Any vehicle subsystem depicted on the figures with the CAN or SCP included uses data derived from the network, or transmits data via the network to achieve control. Messages for both networks are cataloged in the Appendix of this book. In addition to the two networks, the vehicle uses a serial data bus (ISO) for diagnostics, security sounder operation and for the programming of certain control modules.



Table of Contents: Figures .....	3 – 4
Component Index .....	5 – 9
User Instructions .....	10 – 11
Symbols and Codes .....	12 – 15
Connectors .....	16
Main Power Distribution .....	17
Harness Layout .....	18 – 19
Ground Point Location .....	20
Relay and Fuse Box Location .....	21
Control Module Location .....	22 – 23
Control Module Pin Identification .....	24 – 31
Electrical Guide Figures and Data .....	follows after page 31 (pages are numbered by Figure number)
Appendix (CAN and SCP messages) .....	follows Figures and Data



FIGURES

Fig.	Description	Variant
<b>01 Power Distribution</b>		
01.1	Main Power Distribution	All Vehicles
01.2	Battery Power Distribution: Driver and Passenger Fuse Boxes	All Vehicles
01.3	Battery Power Distribution: Trunk, Engine Compartment, EMS Fuse Boxes	All Vehicles
01.4	Ignition Switched Power Distribution	All Vehicles
01.5	Engine Management Switched Power Distribution	All Vehicles
<b>02 Ground Distribution</b>		
02.1	Ignition Switched Ground Distribution	All Vehicles
<b>03 Battery; Starter; Generator</b>		
03.1	Battery; Starter; Generator	AJ27 N/A Vehicles
03.2	Battery; Starter; Generator	AJ27 SC Vehicles
<b>04 Engine Management</b>		
04.1	AJ27 N/A Engine Management: Part 1	AJ27 N/A Vehicles
04.2	AJ27 N/A Engine Management: Part 2	AJ27 N/A Vehicles
04.3	AJ27 SC Engine Management: Part 1	AJ27 SC Vehicles
04.4	AJ27 SC Engine Management: Part 2	AJ27 SC Vehicles
<b>05 Transmission</b>		
05.1	AJ27 N/A Automatic Transmission	AJ27 N/A Vehicles
05.2	AJ27 SC Automatic Transmission	AJ27 SC Vehicles
05.3	Gear Shift Interlock	All Vehicles
<b>06 Chassis</b>		
06.1	Anti-Lock Braking; Traction Control	All Vehicles
06.2	Power Assisted Steering	All Vehicles
06.3	Suspension Adaptive Damping	Adaptive Damping Vehicles
06.4	Adaptive Speed Control	Adaptive Speed Control Vehicles
<b>07 Climate Control</b>		
07.1	Climate Control: Part 1	All Vehicles
07.2	Climate Control: Part 2	All Vehicles
<b>08 Instrumentation; Audible Warnings</b>		
08.1	Instrument Packs	All Vehicles
08.2	Audible Warnings	All Vehicles
<b>09 Exterior Lighting</b>		
09.1	Exterior Lighting: Front	All Vehicles
09.2	Exterior Lighting: Rear	All Vehicles
09.3	Headlamp Leveling	Headlamp Leveling Vehicles
<b>10 Interior Lighting</b>		
10.1	Interior Lighting	All Vehicles
10.2	Dimmer-Controlled Lighting	All Vehicles



**FIGURES**

<b>Fig.</b>	<b>Description</b>	<b>Variant</b>
<b>11</b>	<b>Steering Column; Mirrors</b>	
11.1	Steering Column Movement .....	All Vehicles
11.2	Mirror Movement and Tint .....	All Vehicles
11.3	Interior and Exterior Mirrors; Fold Back Mirrors .....	All Vehicles
<b>12</b>	<b>Seat Systems</b>	
12.1	Driver Seat: Memory .....	Memory Seat Vehicles
12.2	Driver Seat: Non Memory .....	Non Memory Seat Vehicles
12.3	Passenger Seat: 5-Way Movement .....	5-Way Movement Vehicles
12.4	Passenger Seat: 3-Way Movement .....	3-Way Movement Vehicles
<b>13</b>	<b>Door Locking / Security</b>	
13.1	Central Door Locking .....	All Vehicles
13.2	Security System: ROW .....	ROW Vehicles
13.3	Security System: NAS .....	NAS Vehicles
<b>14</b>	<b>Wash / Wipe System</b>	
14.1	Wash / Wipe System .....	All Vehicles
<b>15</b>	<b>Window Lifts; Convertible Top</b>	
15.1	Window Lifts .....	All Vehicles
15.2	Convertible Top .....	Convertible Vehicles
<b>16</b>	<b>In-Car Entertainment</b>	
16.1	Standard In-Car Entertainment .....	Standard ICE Vehicles
16.2	Premium In-Car Entertainment .....	Premium ICE Vehicles
<b>17</b>	<b>Communications; Navigation</b>	
17.1	Cellular Telephone: Portable .....	NAS Vehicles
17.2	Cellular Telephone: Fixed .....	ROW Vehicles
17.3	Navigation System .....	Navigation Only Vehicles
17.4	Navigation System with TV and VICS .....	TV and VICS Vehicles
<b>18</b>	<b>Occupant Safety</b>	
18.1	Advanced Restraint System .....	All Vehicles
<b>19</b>	<b>Driver Assist</b>	
19.1	Reverse Parking Aid .....	Reverse Parking Aid Vehicles
<b>20</b>	<b>Ancillaries</b>	
20.1	Ancillaries: Horns; Cigar Lighters; ..... Accessory Connectors; Garage Door Opener	All Vehicles
<b>21</b>	<b>Vehicle Multiplex Systems</b>	
21.1	CAN (Network); SCP Network; Serial Data Link .....	All Vehicles



ABS / Traction Control Control Module .....	Fig. 06.1	Brake Booster Pressure Sensors .....	Fig. 06.4
.....	Fig. 21.1	Brake Cancel Switch .....	Fig. 04.2
Accelerometers .....	Fig. 06.3	.....	Fig. 04.4
Active Security Sounder .....	Fig. 13.2	.....	Fig. 06.4
.....	Fig. 21.1	Brake Fluid Reservoir .....	Fig. 06.1
Adaptive Damping Control Module .....	Fig. 06.3	Brake Switch .....	Fig. 04.1
.....	Fig. 21.1	.....	Fig. 04.3
Adaptive Speed Control Booster Control Module .....	Fig. 06.4	.....	Fig. 05.3
.....	Fig. 21.1	.....	Fig. 06.1
Adaptive Speed Control Brake Booster .....	Fig. 06.4	.....	Fig. 06.3
Adaptive Speed Control Control Module .....	Fig. 06.4	.....	Fig. 09.2
.....	Fig. 21.1	Canister Close Valve (CCV) .....	Fig. 04.1
Adaptive Speed Control Master Switch .....	Fig. 06.4	.....	Fig. 04.3
Air Assist Close Valve .....	Fig. 04.1	CD Auto-Changer .....	Fig. 16.1
Air Conditioning Compressor Clutch .....	Fig. 04.2	.....	Fig. 16.2
.....	Fig. 04.4	.....	Fig. 17.3
.....	Fig. 07.2	Cellular Phone Control Module .....	Fig. 17.1
Air Conditioning Control Module .....	Fig. 04.2	.....	Fig. 17.2
.....	Fig. 04.4	Center Console Switch Pack .....	Fig. 09.1
.....	Fig. 07.1	.....	Fig. 09.2
.....	Fig. 07.2	.....	Fig. 10.2
.....	Fig. 21.1	Cigar Lighter .....	Fig. 10.2
Air Conditioning Control Panel .....	Fig. 07.1	.....	Fig. 20.1
.....	Fig. 10.2	Crankshaft Position Sensor (CKPS) .....	Fig. 04.1
Air Intake – LH & RH Blower .....	Fig. 07.1	.....	Fig. 04.3
Airbags .....	Fig. 18.1	Camshaft Position Sensors (CMPS) .....	Fig. 04.1
Ambient Temperature Sensor .....	Fig. 07.1	.....	Fig. 04.3
Antenna Motor .....	Fig. 16.1	Column Joy Stick (Column Switchgear) .....	Fig. 11.1
.....	Fig. 16.2	Convertible Top Closed Switch .....	Fig. 15.2
Aspirator Assembly .....	Fig. 07.1	Convertible Top Down Switch .....	Fig. 15.2
Audible Warning Speaker (Column Switchgear) .....	Fig. 08.2	Convertible Top Latch Closed Switch .....	Fig. 15.2
Auto Tilt Switch (Column Switchgear) .....	Fig. 11.1	Convertible Top Pump .....	Fig. 15.2
Battery .....	Fig. 03.1	Convertible Top Raised Switch .....	Fig. 15.2
.....	Fig. 03.2	Convertible Top Ready-To-Latch Switch .....	Fig. 15.2
Blower Motors .....	Fig. 07.2	Convertible Top Switch .....	Fig. 10.2
Body Processor Module .....	Fig. 03.1	.....	Fig. 15.2
.....	Fig. 03.2	Coolant Level Switch .....	Fig. 08.1
.....	Fig. 05.3	Crash Sensors .....	Fig. 18.1
.....	Fig. 08.2	D – 4 Switch .....	Fig. 05.1
.....	Fig. 09.1	Damper Solenoids .....	Fig. 06.3
.....	Fig. 09.2	Data Link Connector .....	Fig. 21.1
.....	Fig. 10.1	Dimmer Control (Column Switchgear) .....	Fig. 10.2
.....	Fig. 11.1	Dimmer Module .....	Fig. 10.2
.....	Fig. 11.2	Diode (BT29) – Trunk Switch .....	Fig. 10.1
.....	Fig. 11.3	Door Control Module – Driver .....	Fig. 10.1
.....	Fig. 12.1	.....	Fig. 11.1
.....	Fig. 12.2	.....	Fig. 11.2
.....	Fig. 12.3	.....	Fig. 11.3
.....	Fig. 12.4	.....	Fig. 12.1
.....	Fig. 13.1	.....	Fig. 13.1
.....	Fig. 13.2	.....	Fig. 13.2
.....	Fig. 13.3	.....	Fig. 13.3
.....	Fig. 14.1	.....	Fig. 15.1
.....	Fig. 15.1	.....	Fig. 15.2
.....	Fig. 15.2	.....	Fig. 15.1
.....	Fig. 20.1	.....	Fig. 15.2
.....	Fig. 21.1	.....	Fig. 21.1



Door Control Module – Passenger .....	Fig. 10.1	External Trunk Release Switch .....	Fig. 13.1
.....	Fig. 11.2	Fascia Accessory Connector .....	Fig. 20.1
.....	Fig. 13.1	Footwell Lamps .....	Fig. 10.1
.....	Fig. 13.2	Front Fog Lamps .....	Fig. 09.1
.....	Fig. 13.3	Front Lamp Units .....	Fig. 09.1
.....	Fig. 15.1	Front Side Markers (NAS only) .....	Fig. 09.1
.....	Fig. 15.2	Fuel Tank Pressure Sensor (FTPS) .....	Fig. 04.1
.....	Fig. 21.1	.....	Fig. 04.3
Door Lock Actuator – Driver .....	Fig. 13.1	Fuel Fill Flap Solenoid .....	Fig. 13.1
Door Lock Actuator – Passenger .....	Fig. 13.1	Fuel Injectors .....	Fig. 04.2
Door Lock Switch – Passenger .....	Fig. 13.1	.....	Fig. 04.4
Door Lock Switches – Driver .....	Fig. 10.1	Fuel Level Sensor .....	Fig. 08.1
.....	Fig. 13.1	Fuel Pump .....	Fig. 04.2
.....	Fig. 13.2	Fuel Pumps .....	Fig. 04.4
.....	Fig. 13.3	Fuse Box – Driver Side .....	Fig. 01.2
.....	Fig. 15.1	.....	Fig. 01.4
Door Mirror Motors – Driver .....	Fig. 11.2	Fuse Box – Engine Compartment .....	Fig. 01.3
Door Mirror Motors – Passenger .....	Fig. 11.2	.....	Fig. 01.4
Door Mirror – Driver .....	Fig. 11.3	.....	Fig. 07.2
Door Mirror – Passenger .....	Fig. 11.3	.....	Fig. 09.1
Door Switch – Driver .....	Fig. 10.1	.....	Fig. 13.2
.....	Fig. 11.1	.....	Fig. 13.3
.....	Fig. 11.2	.....	Fig. 14.1
.....	Fig. 13.1	.....	Fig. 20.1
.....	Fig. 13.2	Fuse Box – Engine Management .....	Fig. 01.3
.....	Fig. 13.3	.....	Fig. 01.5
Door Switch – Passenger .....	Fig. 10.1	Fuse Box – Passenger Side .....	Fig. 01.2
.....	Fig. 13.1	.....	Fig. 01.4
.....	Fig. 13.2	Fuse Box – Trunk .....	Fig. 01.3
.....	Fig. 13.3	.....	Fig. 01.4
Driver Seat Track Switch .....	Fig. 18.1	.....	Fig. 04.2
Dual Linear Switch .....	Fig. 03.2	.....	Fig. 04.4
.....	Fig. 05.2	.....	Fig. 07.2
ECM and TCM Cooling Fan .....	Fig. 04.1	.....	Fig. 09.2
.....	Fig. 04.3	.....	Fig. 20.1
Engine Coolant Temperature Sensor (ECTS) .....	Fig. 04.1	Garage Door Opener (Roof Console) .....	Fig. 20.1
.....	Fig. 04.3	Gear Selector Illumination Module .....	Fig. 05.1
Engine Coolant Temperature Sensor (ECTS) .....	Fig. 04.1	.....	Fig. 05.2
.....	Fig. 04.3	.....	Fig. 05.3
EGR Valve .....	Fig. 04.3	.....	Fig. 10.2
Engine Compartment Security Switch .....	Fig. 13.2	.....	Fig. 21.1
.....	Fig. 13.3	Gearshift Interlock Solenoid .....	Fig. 05.3
Engine Control Module .....	Fig. 03.1	Generator .....	Fig. 03.1
.....	Fig. 03.2	Glass Breakage Sensor (Roof Console) .....	Fig. 13.2
.....	Fig. 04.1	Glove Box Lamp .....	Fig. 10.1
.....	Fig. 04.2	Head Restraint Control Module – Driver .....	Fig. 12.1
.....	Fig. 04.3	.....	Fig. 12.2
.....	Fig. 04.4	.....	Fig. 21.1
.....	Fig. 05.3	Head Restraint Control Module – Passenger .....	Fig. 12.3
.....	Fig. 06.4	.....	Fig. 12.4
.....	Fig. 07.2	.....	Fig. 21.1
.....	Fig. 13.2	Head Restraint Motor – Driver .....	Fig. 12.1
.....	Fig. 13.3	.....	Fig. 12.2
.....	Fig. 21.1	Head Restraint Motor – Passenger .....	Fig. 12.3
Engine Oil Temperature Sensor (EOTS) .....	Fig. 04.1	.....	Fig. 12.4
.....	Fig. 04.3		
Evaporator / Heater Matrix Assembly .....	Fig. 07.1		
Evaporative Emission Control Valve (EVAPP) .....	Fig. 04.1		
.....	Fig. 04.3		





Headlamp Leveling Actuators .....	Fig. 09.3	Major Instrument Pack .....	Fig. 05.3
Heated Backlight .....	Fig. 07.2	.....	Fig. 08.1
Heater Pump .....	Fig. 07.2	.....	Fig. 09.1
Heater Valve .....	Fig. 07.2	.....	Fig. 09.2
High Mount Stop Lamp .....	Fig. 09.2	.....	Fig. 10.2
High Power Protection Module .....	Fig. 03.1	.....	Fig. 11.2
.....	Fig. 03.2	.....	Fig. 11.3
Heated Oxygen Sensors (HO2S) .....	Fig. 04.1	.....	Fig. 13.2
.....	Fig. 04.3	.....	Fig. 13.3
Horn Switches (Steering Wheel) .....	Fig. 20.1	.....	Fig. 15.1
Horns .....	Fig. 13.2	.....	Fig. 15.2
.....	Fig. 13.3	.....	Fig. 16.1
.....	Fig. 20.1	.....	Fig. 16.2
Intake Air Temperature Sensor 2 (IATS 2) .....	Fig. 04.3	.....	Fig. 17.3
Ignition Coils .....	Fig. 04.2	.....	Fig. 17.4
.....	Fig. 04.4	.....	Fig. 21.1
Ignition Switch (Key-In Switch) .....	Fig. 02.1	Manifold Absolute Pressure Sensor (MAPS) .....	Fig. 04.3
.....	Fig. 03.1	Minor Instrument Pack .....	Fig. 08.1
.....	Fig. 03.2	.....	Fig. 10.2
.....	Fig. 10.1	Mirror Joy Stick (Driver Door Switch Pack) .....	Fig. 11.3
.....	Fig. 11.1	.....	Fig. 11.2
.....	Fig. 13.1	Mirrors .....	Fig. 07.2
Ignitors (Airbag) .....	Fig. 18.1	Mode Switch (Transmission) .....	Fig. 05.1
Inclination Sensor .....	Fig. 13.2	.....	Fig. 05.2
Inertia Switch .....	Fig. 02.1	.....	Fig. 10.2
Intercooler Pump .....	Fig. 04.4	Navigation Control Module .....	Fig. 10.2
Interior Rear View Mirror .....	Fig. 11.3	.....	Fig. 17.3
.....	Fig. 14.1	.....	Fig. 17.4
Key Fob Antenna .....	Fig. 13.1	Navigation Display .....	Fig. 10.2
.....	Fig. 13.2	.....	Fig. 17.3
.....	Fig. 13.3	.....	Fig. 17.4
Key Transponder Module .....	Fig. 03.1	Navigation GPS Antenna .....	Fig. 17.3
.....	Fig. 03.2	.....	Fig. 17.4
.....	Fig. 13.2	Neutral Switch .....	Fig. 03.1
.....	Fig. 13.3	Not-In-Park Microswitch .....	Fig. 05.3
.....	Fig. 21.1	.....	Fig. 11.1
Keylock Solenoid (Column Switchgear) .....	Fig. 05.3	.....	Fig. 11.2
Kickdown Switch .....	Fig. 05.2	.....	Fig. 13.1
Knock Sensors (KS) .....	Fig. 04.1	Number Plate Lamps .....	Fig. 09.2
.....	Fig. 04.3	Occupancy Sensors .....	Fig. 18.1
Latch Control Valve .....	Fig. 15.2	Occupancy Sensing Module .....	Fig. 18.1
Leveling Switch (Center Console Switch Pack) .....	Fig. 09.3	Oil Pressure Switch .....	Fig. 08.1
Lighting Stalk (Column Switchgear) .....	Fig. 09.1	Oxygen Sensors (O2S) .....	Fig. 04.1
.....	Fig. 09.2	Parking Aid Sensors .....	Fig. 19.1
.....	Fig. 10.2	Parking Aid Sounder .....	Fig. 19.1
.....	Fig. 11.3	Parking Brake Switch .....	Fig. 04.1
.....	Fig. 14.1	.....	Fig. 17.4
Mass Air Flow Sensor (MAFS) .....	Fig. 04.1	Passenger Airbag Deactivated Indicator Lamp .....	Fig. 18.1
.....	Fig. 04.3	Passenger Seat Weight Pressure Sensor .....	Fig. 18.1
Main Control Valve .....	Fig. 15.2	Passenger Seat Weight Sensing Module .....	Fig. 18.1
		Passive Security Sounder .....	Fig. 13.2
		.....	Fig. 13.3
		Power Amplifier .....	Fig. 16.2
		.....	Fig. 17.3
		.....	Fig. 17.4
		Power Assisted Steering Control Module .....	Fig. 06.2



Powerwash Pump .....	Fig. 14.1	Seat Control Module – Driver .....	Fig. 11.3
Pedal Position Sensors (PPS) .....	Fig. 04.1	.....	Fig. 12.1
.....	Fig. 04.3	.....	Fig. 12.2
Puddle Lamps .....	Fig. 10.1	.....	Fig. 21.1
Quarter Light Lifts .....	Fig. 15.2	Seat Control Module – Passenger .....	Fig. 11.3
Radiator Fan Control Relay Module .....	Fig. 04.2	.....	Fig. 12.3
.....	Fig. 04.4	.....	Fig. 12.4
.....	Fig. 07.2	.....	Fig. 21.1
Radiator Fans .....	Fig. 04.2	Seat Cushion (Heater) – Driver .....	Fig. 12.1
.....	Fig. 04.4	.....	Fig. 12.2
.....	Fig. 07.2	Seat Cushion (Heater) – Passenger .....	Fig. 12.3
Radio / Cassette Head Unit .....	Fig. 10.2	.....	Fig. 12.4
.....	Fig. 16.1	Seat Heater Switch (Center Console Switch Pack) .....	Fig. 12.1
.....	Fig. 16.2	.....	Fig. 12.2
.....	Fig. 17.3	.....	Fig. 12.3
.....	Fig. 17.4	.....	Fig. 12.4
Radio Antenna .....	Fig. 16.1	Seat Lumbar Pump – Driver .....	Fig. 12.1
.....	Fig. 16.2	.....	Fig. 12.2
Radio Control Switches (Steering Wheel) .....	Fig. 16.1	Seat Lumbar Pump – Passenger .....	Fig. 12.3
.....	Fig. 16.2	.....	Fig. 12.4
Rain Sensing Module .....	Fig. 14.1	Seat Motors – Driver .....	Fig. 12.1
Rain Sensor .....	Fig. 14.1	.....	Fig. 12.2
Reader / Exciter Coil (Column Switchgear) .....	Fig. 13.2	Seat Motors – Passenger .....	Fig. 12.3
.....	Fig. 13.3	.....	Fig. 12.4
Rear Interior Lamp (Coupe Only) .....	Fig. 10.1	Security Active Indicator .....	Fig. 13.2
Rear Side Markers (NAS Only) .....	Fig. 09.2	.....	Fig. 13.3
Refrigerant 4-Way Pressure Switch .....	Fig. 04.2	Security and Locking Control Module .....	Fig. 09.2
.....	Fig. 04.4	.....	Fig. 11.3
.....	Fig. 07.2	.....	Fig. 13.1
Regulator (Generator) .....	Fig. 03.1	.....	Fig. 13.2
.....	Fig. 03.2	.....	Fig. 13.3
Restraints Control Module .....	Fig. 18.1	.....	Fig. 15.1
.....	Fig. 21.1	.....	Fig. 15.2
Reverse Parking Aid Control Module .....	Fig. 19.1	.....	Fig. 21.1
Roof Console .....	Fig. 10.1	Side DI Repeaters (ROW) .....	Fig. 09.1
.....	Fig. 10.2	Solar Sensor .....	Fig. 07.1
.....	Fig. 13.3	Speakers – Mid-Bass .....	Fig. 16.1
Seat Back Latch Switch – Driver .....	Fig. 12.1	.....	Fig. 16.2
.....	Fig. 12.2	Speakers – Tweeter .....	Fig. 16.2
Seat Back Latch Switch – Passenger .....	Fig. 12.3	Speakers – Fascia .....	Fig. 16.1
.....	Fig. 12.4	.....	Fig. 16.2
Seat Back Tilt Switch – Driver .....	Fig. 12.1	Speakers – Rear (Convertible) .....	Fig. 16.1
.....	Fig. 12.2	.....	Fig. 16.2
Seat Back Tilt Switch – Passenger .....	Fig. 12.3	Speakers – Rear Quarter .....	Fig. 16.1
.....	Fig. 12.4	.....	Fig. 16.2
Seat Belt Comfort Solenoid – Driver .....	Fig. 12.1	Speaker – Rear (Coupe) .....	Fig. 16.2
.....	Fig. 12.2	Speed Control On / Off Switch .....	Fig. 04.2
Seat Belt Comfort Solenoid – Passenger .....	Fig. 12.3	.....	Fig. 04.4
.....	Fig. 12.4	.....	Fig. 10.2
Seat Belt Switch – Driver .....	Fig. 12.1	Speed Control Switches (Steering Wheel) .....	Fig. 04.2
.....	Fig. 12.2	.....	Fig. 04.4
.....	Fig. 18.1	.....	Fig. 06.4
Seat Belt Switch – Passenger .....	Fig. 12.3	Squab (Heater) – Driver .....	Fig. 12.1
.....	Fig. 12.4	.....	Fig. 12.2
.....	Fig. 18.1	Squab (Heater) – Passenger .....	Fig. 12.3
		.....	Fig. 12.4
		Stability / Traction Control Switch .....	Fig. 06.1



Starter Motor .....	Fig. 03.1	Vehicle Information Control Infrared Sensor .....	Fig. 17.4
.....	Fig. 03.2	Vehicle Information Control Module .....	Fig. 17.4
Steering Column Motors .....	Fig. 11.1	Vent Assembly .....	Fig. 07.1
Suppression Module .....	Fig. 03.1	Variable Valve Timing Solenoid Valves (VVT Solenoid Valves) .....	Fig. 04.1
.....	Fig. 03.2	Wash / Wipe Stalk (Column Switchgear) .....	Fig. 14.1
Switch Pack – Driver Door .....	Fig. 10.2	Wheel Speed Sensors .....	Fig. 06.1
Switch Pack – Driver Door Memory .....	Fig. 10.2	Window Lift Switches – Driver Door .....	Fig. 15.1
.....	Fig. 11.1	Window Lift Switches – Passenger Door .....	Fig. 15.1
.....	Fig. 11.2	Window Lift – Driver .....	Fig. 15.1
.....	Fig. 12.1	Window Lift – Passenger .....	Fig. 15.1
Switch Pack – Driver Seat .....	Fig. 12.1	Windshield Heaters .....	Fig. 07.2
.....	Fig. 12.2	Windshield Wash Pump and Fluid Level Sensor .....	Fig. 14.1
Switch Pack – Passenger Door .....	Fig. 10.2	Wiper Motor .....	Fig. 14.1
Switch Pack – Passenger Seat .....	Fig. 12.3		
.....	Fig. 12.4		
Tail Lamp Units .....	Fig. 09.2		
Telephone Antenna .....	Fig. 17.1		
.....	Fig. 17.2		
Telephone Handset .....	Fig. 17.1		
.....	Fig. 17.2		
Telephone Microphone .....	Fig. 17.1		
.....	Fig. 17.2		
Television Antenna Amplifier .....	Fig. 17.4		
Television Antennas .....	Fig. 17.4		
Television Module .....	Fig. 17.4		
Throttle Motor .....	Fig. 04.1		
.....	Fig. 04.3		
Throttle Position Sensors (TPS) .....	Fig. 04.1		
.....	Fig. 04.3		
Transmission Control Module: AJ27 N/A .....	Fig. 05.1		
.....	Fig. 06.4		
.....	Fig. 21.1		
Transmission Control Module: AJ27 SC .....	Fig. 05.2		
.....	Fig. 21.1		
Transmission Rotary Switch .....	Fig. 05.1		
Trip Computer Switch Pack .....	Fig. 08.1		
.....	Fig. 10.2		
Trip Cycle Switch (Column Switchgear) .....	Fig. 08.1		
Trunk Accessory Connector .....	Fig. 20.1		
Trunk and Fuel Fill Release Switch .....	Fig. 10.2		
.....	Fig. 13.1		
Trunk Lamps .....	Fig. 10.1		
Trunk Release Solenoid .....	Fig. 13.1		
Trunk Switch .....	Fig. 10.1		
.....	Fig. 13.1		
.....	Fig. 13.2		
.....	Fig. 13.3		
Valet Switch .....	Fig. 10.2		
.....	Fig. 13.1		
.....	Fig. 13.2		
.....	Fig. 13.3		
Vanity Lamps .....	Fig. 10.1		
Variable Steering Converter .....	Fig. 06.2		
Vehicle Information Control Beacon Module .....	Fig. 17.4		



## Figure and Data Page Layout

### Figure Pages

Each Figure represents a specific electrical system of the vehicle. The Figures are arranged numerically by system (**01 – Power Distribution**, **02 – Ground Distribution**, etc.) with variations in the system identified by a numeral following a decimal point (**01.1**, **01.2**, etc.). Refer to the Table of Contents for a complete list of the Figures.

The Figures **01 – Power Distribution** detail the distribution of power to each of the systems. Numbered reference symbols refer the user *to* a specific Figure and *from* a specific Figure back to the Power Distribution Figures. This method eliminates the need to include detailed Power Distribution information on each of the Figures. Similarly, the Figure **02 – Ground Distribution** details the ignition switched ground distribution. The reference symbols are defined on page 12.

Each Figure appears on a right-hand page with a corresponding Data page to the left. The Figure and Data pages are folding pages. The user must fold out both pages in order to access all the information provided.

### Data Pages

The Data page includes information to assist the user in identifying and locating components, connectors and grounds. This information is supplemented by the illustrations in this front section of the book.

When network data is required for the understanding of a particular circuit, the user is directed to the Appendix.

Where circuits include a Control Module, Pin Out information is provided with values for “active” and “inactive” states. The values listed are approximately those that can be expected at the control module connector pins with all circuit connections made and all components connected and fitted. “Active” means a load is applied or a switch is ON; “inactive” means a load is not applied or a switch is OFF. This information is provided to assist the user in understanding circuit operation and should be used FOR REFERENCE ONLY.



CONTROL MODULE PIN OUT INFORMATION	FIGURE NUMBER	COMPONENT, RELAY, CONNECTOR AND GROUND INFORMATION																																																																																																																																								
<p><b>CONTROL MODULE PIN OUT INFORMATION</b></p> <p><b>BODY PROCESSOR MODULE</b></p> <table border="1"> <tr> <th>Pin</th> <th>Description</th> <th>Active</th> <th>Inactive</th> </tr> <tr> <td>FC147</td> <td>MULTIPLY SWITCH SIGNAL</td> <td>GROUND (B)</td> <td>B-PK 0.4 L R</td> </tr> <tr> <td>FC148</td> <td>SECURITY KNOWLEDGE</td> <td>ENCLOSED COMMUNICATIONS</td> <td>B-</td> </tr> <tr> <td>FC149</td> <td>STARTER CHARGE REQUEST</td> <td>GROUND (COMMON)</td> <td>B-</td> </tr> <tr> <td>FC150</td> <td>STARTER CHARGE REQUEST</td> <td>GROUND (COMMON)</td> <td>B-</td> </tr> <tr> <td>FC151</td> <td>BATTERY SUPPLY VOLTAGE</td> <td>B-</td> <td></td> </tr> <tr> <td>FC152</td> <td>ENCLOSED COMMUNICATIONS</td> <td>B-</td> <td></td> </tr> </table> <p><b>ENGINE CONTROL MODULE</b></p> <table border="1"> <tr> <th>Pin</th> <th>Description</th> <th>Active</th> <th>Inactive</th> </tr> <tr> <td>EM102</td> <td>FASE SIGNAL INDICATION</td> <td>B-PK 0.6</td> <td>GROUND (B) 0.4 L R</td> </tr> <tr> <td>EM107</td> <td>ENGINE GEAR</td> <td>GROUND (COMMON)</td> <td></td> </tr> <tr> <td>EM108</td> <td>ON-TIMEOUT</td> <td>ENCLOSED COMMUNICATIONS</td> <td></td> </tr> <tr> <td>EM109</td> <td>SECURITY KNOWLEDGE</td> <td>ENCLOSED COMMUNICATIONS</td> <td></td> </tr> </table> <p><b>KEY TRANSMITTER MODULE</b></p> <table border="1"> <tr> <th>Pin</th> <th>Description</th> <th>Active</th> <th>Inactive</th> </tr> <tr> <td>FC149</td> <td>STARTER CHARGE REQUEST (ENCLOSED COMMUNICATIONS)</td> <td></td> <td></td> </tr> <tr> <td>FC150</td> <td>STARTER CHARGE REQUEST (ENCLOSED COMMUNICATIONS)</td> <td></td> <td></td> </tr> <tr> <td>FC151</td> <td>BATTERY SUPPLY VOLTAGE (ENCLOSED COMMUNICATIONS)</td> <td></td> <td></td> </tr> <tr> <td>FC152</td> <td>SECURITY KNOWLEDGE (ENCLOSED COMMUNICATIONS)</td> <td></td> <td></td> </tr> </table>	Pin	Description	Active	Inactive	FC147	MULTIPLY SWITCH SIGNAL	GROUND (B)	B-PK 0.4 L R	FC148	SECURITY KNOWLEDGE	ENCLOSED COMMUNICATIONS	B-	FC149	STARTER CHARGE REQUEST	GROUND (COMMON)	B-	FC150	STARTER CHARGE REQUEST	GROUND (COMMON)	B-	FC151	BATTERY SUPPLY VOLTAGE	B-		FC152	ENCLOSED COMMUNICATIONS	B-		Pin	Description	Active	Inactive	EM102	FASE SIGNAL INDICATION	B-PK 0.6	GROUND (B) 0.4 L R	EM107	ENGINE GEAR	GROUND (COMMON)		EM108	ON-TIMEOUT	ENCLOSED COMMUNICATIONS		EM109	SECURITY KNOWLEDGE	ENCLOSED COMMUNICATIONS		Pin	Description	Active	Inactive	FC149	STARTER CHARGE REQUEST (ENCLOSED COMMUNICATIONS)			FC150	STARTER CHARGE REQUEST (ENCLOSED COMMUNICATIONS)			FC151	BATTERY SUPPLY VOLTAGE (ENCLOSED COMMUNICATIONS)			FC152	SECURITY KNOWLEDGE (ENCLOSED COMMUNICATIONS)			<p><b>Fig. 03.1</b></p> <table border="1"> <thead> <tr> <th>Component</th> <th>Connector / Type / Color</th> <th>Location / Access</th> </tr> </thead> <tbody> <tr> <td>BATTERY</td> <td>B14a-EYELET B14b-EYELET</td> <td>TRUNK, RIGHT HAND SIDE</td> </tr> <tr> <td>BODY PROCESSOR MODULE</td> <td>FC147-18 AWG AMP (20) - WHITE FC148-17 AWG AMP (20) - NATURAL FC149-18 AWG AMP (20) - NATURAL FC150-18 AWG AMP (20) - NATURAL FC151-18 AWG AMP (20) - NATURAL FC152-18 AWG AMP (20) - WHITE</td> <td>FRONT/REAR SIDE PANEL (HARNESS BUNDLE) ENGINE COMPARTMENT (CONTROL MODULE ENCLOSURE)</td> </tr> <tr> <td>GENERATOR</td> <td>AN1-EYELET AN2-EYELET AN3-EYELET AN4-EYELET AN5-EYELET</td> <td>ENGINE COMPARTMENT (RIGHT FRONT)</td> </tr> <tr> <td>HIGH POWER PROTECTION MODULE</td> <td>AN1-EYELET AN2-EYELET AN3-EYELET AN4-EYELET AN5-EYELET</td> <td>TRUNK (ADJACENT TO BATTERY)</td> </tr> <tr> <td>STARTER SWITCH (KEY IN SWITCH)</td> <td>FC22-18 AWG MULTICOLORED (3) - WHITE FC23-18 AWG MULTICOLORED (4) - GREEN FC24-18 AWG MULTICOLORED (4) - RED FC25-18 AWG MULTICOLORED (4) - BLACK FC26-18 AWG MULTICOLORED (4) - BLACK</td> <td>STEERING COLUMN ADJACENT TO CHARGE METER FUSE BOX CLASH DETECTION ADJUSTMENT</td> </tr> <tr> <td>KEY TRANSMITTER MODULE</td> <td>FC149-18 AWG AMP (20) - NATURAL FC150-18 AWG AMP (20) - NATURAL FC151-18 AWG AMP (20) - NATURAL FC152-18 AWG AMP (20) - NATURAL</td> <td>ENGINE COMPARTMENT (TRANSMITTER)</td> </tr> <tr> <td>STARTER MOTOR</td> <td>ST1-EYELET ST2-EYELET</td> <td>ENGINE BLOCK</td> </tr> <tr> <td>SUPPRESSION MODULE</td> <td>AN1-18 AWG COAXIAL (8) - RED</td> <td>REARWARD OF RIGHT FRONT HEADLAMP</td> </tr> </tbody> </table> <table border="1"> <thead> <tr> <th>Relay</th> <th>Color / Stripe</th> <th>Connector / Color</th> <th>Location / Access</th> </tr> </thead> <tbody> <tr> <td>STARTER RELAY</td> <td>GREEN</td> <td>B501 - GREEN</td> <td>IN ENCLOSURE (RELAYS)</td> </tr> </tbody> </table> <table border="1"> <thead> <tr> <th>Harness-to-harness Connectors</th> <th>Type / Color</th> <th>Location / Access</th> </tr> </thead> <tbody> <tr> <td>B14a</td> <td>EYELET</td> <td>ENGINE COMPARTMENT (FALSE BULKHEAD, RIGHT HAND SIDE)</td> </tr> <tr> <td>B14b</td> <td>EYELET</td> <td>ENGINE COMPARTMENT (FALSE BULKHEAD, RIGHT HAND SIDE)</td> </tr> <tr> <td>B14c</td> <td>18 AWG MULTICOLORED (4) - WHITE</td> <td>ENGINE COMPARTMENT (ADJACENT TO RIGHT HAND ENCLOSURE)</td> </tr> <tr> <td>B14d</td> <td>18 AWG MULTICOLORED (4) - YELLOW</td> <td>ENGINE COMPARTMENT (ADJACENT TO RIGHT HAND ENCLOSURE)</td> </tr> <tr> <td>B14e</td> <td>18 AWG MULTICOLORED (4) - GREEN</td> <td>ENGINE COMPARTMENT (ADJACENT TO RIGHT HAND ENCLOSURE)</td> </tr> <tr> <td>B14f</td> <td>18 AWG COAXIAL (8) - RED</td> <td>ENGINE COMPARTMENT (REARWARD OF RIGHT FRONT HEADLAMP)</td> </tr> <tr> <td>B14g</td> <td>18 AWG COAXIAL (8) - BLACK</td> <td>ENGINE COMPARTMENT (REARWARD OF RIGHT FRONT HEADLAMP)</td> </tr> <tr> <td>B14h</td> <td>18 AWG MULTICOLORED (4) - BLACK</td> <td>ENGINE COMPARTMENT (FALSE BULKHEAD, RIGHT HAND SIDE)</td> </tr> </tbody> </table> <table border="1"> <thead> <tr> <th>Ground</th> <th>Location / Type</th> </tr> </thead> <tbody> <tr> <td>B14</td> <td>BATTERY GROUND (3-TUD)</td> </tr> <tr> <td>FC149</td> <td>EYELET (3-PIN) - RIGHT WHEEL (TRANSMISSION TUNNEL, LEFT HAND SIDE)</td> </tr> </tbody> </table> <p>FOR CONTROL MODULE PIN OUT INFORMATION, UNFOLD PAGE TO LEFT.</p>	Component	Connector / Type / Color	Location / Access	BATTERY	B14a-EYELET B14b-EYELET	TRUNK, RIGHT HAND SIDE	BODY PROCESSOR MODULE	FC147-18 AWG AMP (20) - WHITE FC148-17 AWG AMP (20) - NATURAL FC149-18 AWG AMP (20) - NATURAL FC150-18 AWG AMP (20) - NATURAL FC151-18 AWG AMP (20) - NATURAL FC152-18 AWG AMP (20) - WHITE	FRONT/REAR SIDE PANEL (HARNESS BUNDLE) ENGINE COMPARTMENT (CONTROL MODULE ENCLOSURE)	GENERATOR	AN1-EYELET AN2-EYELET AN3-EYELET AN4-EYELET AN5-EYELET	ENGINE COMPARTMENT (RIGHT FRONT)	HIGH POWER PROTECTION MODULE	AN1-EYELET AN2-EYELET AN3-EYELET AN4-EYELET AN5-EYELET	TRUNK (ADJACENT TO BATTERY)	STARTER SWITCH (KEY IN SWITCH)	FC22-18 AWG MULTICOLORED (3) - WHITE FC23-18 AWG MULTICOLORED (4) - GREEN FC24-18 AWG MULTICOLORED (4) - RED FC25-18 AWG MULTICOLORED (4) - BLACK FC26-18 AWG MULTICOLORED (4) - BLACK	STEERING COLUMN ADJACENT TO CHARGE METER FUSE BOX CLASH DETECTION ADJUSTMENT	KEY TRANSMITTER MODULE	FC149-18 AWG AMP (20) - NATURAL FC150-18 AWG AMP (20) - NATURAL FC151-18 AWG AMP (20) - NATURAL FC152-18 AWG AMP (20) - NATURAL	ENGINE COMPARTMENT (TRANSMITTER)	STARTER MOTOR	ST1-EYELET ST2-EYELET	ENGINE BLOCK	SUPPRESSION MODULE	AN1-18 AWG COAXIAL (8) - RED	REARWARD OF RIGHT FRONT HEADLAMP	Relay	Color / Stripe	Connector / Color	Location / Access	STARTER RELAY	GREEN	B501 - GREEN	IN ENCLOSURE (RELAYS)	Harness-to-harness Connectors	Type / Color	Location / Access	B14a	EYELET	ENGINE COMPARTMENT (FALSE BULKHEAD, RIGHT HAND SIDE)	B14b	EYELET	ENGINE COMPARTMENT (FALSE BULKHEAD, RIGHT HAND SIDE)	B14c	18 AWG MULTICOLORED (4) - WHITE	ENGINE COMPARTMENT (ADJACENT TO RIGHT HAND ENCLOSURE)	B14d	18 AWG MULTICOLORED (4) - YELLOW	ENGINE COMPARTMENT (ADJACENT TO RIGHT HAND ENCLOSURE)	B14e	18 AWG MULTICOLORED (4) - GREEN	ENGINE COMPARTMENT (ADJACENT TO RIGHT HAND ENCLOSURE)	B14f	18 AWG COAXIAL (8) - RED	ENGINE COMPARTMENT (REARWARD OF RIGHT FRONT HEADLAMP)	B14g	18 AWG COAXIAL (8) - BLACK	ENGINE COMPARTMENT (REARWARD OF RIGHT FRONT HEADLAMP)	B14h	18 AWG MULTICOLORED (4) - BLACK	ENGINE COMPARTMENT (FALSE BULKHEAD, RIGHT HAND SIDE)	Ground	Location / Type	B14	BATTERY GROUND (3-TUD)	FC149	EYELET (3-PIN) - RIGHT WHEEL (TRANSMISSION TUNNEL, LEFT HAND SIDE)	<p><b>DATA PAGE</b></p>
Pin	Description	Active	Inactive																																																																																																																																							
FC147	MULTIPLY SWITCH SIGNAL	GROUND (B)	B-PK 0.4 L R																																																																																																																																							
FC148	SECURITY KNOWLEDGE	ENCLOSED COMMUNICATIONS	B-																																																																																																																																							
FC149	STARTER CHARGE REQUEST	GROUND (COMMON)	B-																																																																																																																																							
FC150	STARTER CHARGE REQUEST	GROUND (COMMON)	B-																																																																																																																																							
FC151	BATTERY SUPPLY VOLTAGE	B-																																																																																																																																								
FC152	ENCLOSED COMMUNICATIONS	B-																																																																																																																																								
Pin	Description	Active	Inactive																																																																																																																																							
EM102	FASE SIGNAL INDICATION	B-PK 0.6	GROUND (B) 0.4 L R																																																																																																																																							
EM107	ENGINE GEAR	GROUND (COMMON)																																																																																																																																								
EM108	ON-TIMEOUT	ENCLOSED COMMUNICATIONS																																																																																																																																								
EM109	SECURITY KNOWLEDGE	ENCLOSED COMMUNICATIONS																																																																																																																																								
Pin	Description	Active	Inactive																																																																																																																																							
FC149	STARTER CHARGE REQUEST (ENCLOSED COMMUNICATIONS)																																																																																																																																									
FC150	STARTER CHARGE REQUEST (ENCLOSED COMMUNICATIONS)																																																																																																																																									
FC151	BATTERY SUPPLY VOLTAGE (ENCLOSED COMMUNICATIONS)																																																																																																																																									
FC152	SECURITY KNOWLEDGE (ENCLOSED COMMUNICATIONS)																																																																																																																																									
Component	Connector / Type / Color	Location / Access																																																																																																																																								
BATTERY	B14a-EYELET B14b-EYELET	TRUNK, RIGHT HAND SIDE																																																																																																																																								
BODY PROCESSOR MODULE	FC147-18 AWG AMP (20) - WHITE FC148-17 AWG AMP (20) - NATURAL FC149-18 AWG AMP (20) - NATURAL FC150-18 AWG AMP (20) - NATURAL FC151-18 AWG AMP (20) - NATURAL FC152-18 AWG AMP (20) - WHITE	FRONT/REAR SIDE PANEL (HARNESS BUNDLE) ENGINE COMPARTMENT (CONTROL MODULE ENCLOSURE)																																																																																																																																								
GENERATOR	AN1-EYELET AN2-EYELET AN3-EYELET AN4-EYELET AN5-EYELET	ENGINE COMPARTMENT (RIGHT FRONT)																																																																																																																																								
HIGH POWER PROTECTION MODULE	AN1-EYELET AN2-EYELET AN3-EYELET AN4-EYELET AN5-EYELET	TRUNK (ADJACENT TO BATTERY)																																																																																																																																								
STARTER SWITCH (KEY IN SWITCH)	FC22-18 AWG MULTICOLORED (3) - WHITE FC23-18 AWG MULTICOLORED (4) - GREEN FC24-18 AWG MULTICOLORED (4) - RED FC25-18 AWG MULTICOLORED (4) - BLACK FC26-18 AWG MULTICOLORED (4) - BLACK	STEERING COLUMN ADJACENT TO CHARGE METER FUSE BOX CLASH DETECTION ADJUSTMENT																																																																																																																																								
KEY TRANSMITTER MODULE	FC149-18 AWG AMP (20) - NATURAL FC150-18 AWG AMP (20) - NATURAL FC151-18 AWG AMP (20) - NATURAL FC152-18 AWG AMP (20) - NATURAL	ENGINE COMPARTMENT (TRANSMITTER)																																																																																																																																								
STARTER MOTOR	ST1-EYELET ST2-EYELET	ENGINE BLOCK																																																																																																																																								
SUPPRESSION MODULE	AN1-18 AWG COAXIAL (8) - RED	REARWARD OF RIGHT FRONT HEADLAMP																																																																																																																																								
Relay	Color / Stripe	Connector / Color	Location / Access																																																																																																																																							
STARTER RELAY	GREEN	B501 - GREEN	IN ENCLOSURE (RELAYS)																																																																																																																																							
Harness-to-harness Connectors	Type / Color	Location / Access																																																																																																																																								
B14a	EYELET	ENGINE COMPARTMENT (FALSE BULKHEAD, RIGHT HAND SIDE)																																																																																																																																								
B14b	EYELET	ENGINE COMPARTMENT (FALSE BULKHEAD, RIGHT HAND SIDE)																																																																																																																																								
B14c	18 AWG MULTICOLORED (4) - WHITE	ENGINE COMPARTMENT (ADJACENT TO RIGHT HAND ENCLOSURE)																																																																																																																																								
B14d	18 AWG MULTICOLORED (4) - YELLOW	ENGINE COMPARTMENT (ADJACENT TO RIGHT HAND ENCLOSURE)																																																																																																																																								
B14e	18 AWG MULTICOLORED (4) - GREEN	ENGINE COMPARTMENT (ADJACENT TO RIGHT HAND ENCLOSURE)																																																																																																																																								
B14f	18 AWG COAXIAL (8) - RED	ENGINE COMPARTMENT (REARWARD OF RIGHT FRONT HEADLAMP)																																																																																																																																								
B14g	18 AWG COAXIAL (8) - BLACK	ENGINE COMPARTMENT (REARWARD OF RIGHT FRONT HEADLAMP)																																																																																																																																								
B14h	18 AWG MULTICOLORED (4) - BLACK	ENGINE COMPARTMENT (FALSE BULKHEAD, RIGHT HAND SIDE)																																																																																																																																								
Ground	Location / Type																																																																																																																																									
B14	BATTERY GROUND (3-TUD)																																																																																																																																									
FC149	EYELET (3-PIN) - RIGHT WHEEL (TRANSMISSION TUNNEL, LEFT HAND SIDE)																																																																																																																																									

The following abbreviations are used to represent values for Control Module Pin-Out data

I	Input	SG	Sensor Ground	S	SCP Network	V	Voltage (DC)
O	Output	A	ACP Network	D	D Serial and Encoded Data	Hz	Frequency
SS	Sensor Supply V	C	CAN (Network)	B+	Battery Voltage	KHz	Frequency x 1000

**CAUTION:** The information on this data page is furnished to aid the user in understanding circuit operation. THIS INFORMATION SHOULD BE USED FOR REFERENCE ONLY.

**NOTE:** The values listed are approximately those that can be expected at the control module connector pins with all circuit connections made and all components connected and fitted. "Active" means a load is applied or a switch is ON; "Inactive" means a load is not applied or a switch is OFF.

Refer to the front of this book for detailed information and illustrations regarding the location and identification of harnesses, relays, grounds, control modules and control module pins.

DATE OF ISSUE: September 2000

DATE OF ISSUE

FIGURE	MODEL RANGE AND YEAR	TITLE	FIGURE NUMBER
	XK8 Range 2001	Battery: Starter: Generator: AJ27 N/A	Fig. 03.1

KEY TO REFERENCE SYMBOLS

--	--	--	--	--	--	--	--	--	--	--	--	--	--	--	--	--	--	--	--

VARIANT: AJ27 N/A Vehicles  
VIN RANGE: A1101 ->  
DATE OF ISSUE: September 2000

**FIGURE PAGE**

DATE OF ISSUE: September 2000

11



**NOTE:** In the examples shown on this page, an 'X' is used where a number would appear on an actual Figure.

## Reference Symbols

Reference symbols are used for three purposes:

- to allow the user to complete the individual system circuit to power supply or ground
- to refer the user to a related circuit
- to identify control module inputs, outputs and signal grounds

### **Battery Power Supply**

This symbol represents a direct battery power supply and refers the user to Figure 01.1, 01.2 or 01.3.

### **Ignition Switched Power Supply**

This symbol represents ignition switched power supply and refers the user to Figure 01.1, 01.4 or 01.5.

The suffix I indicates auxiliary power. Power is supplied in ignition switch key positions I (AUXILIARY) and II (IGNITION).

The suffix II indicates ignition power. Power is supplied in ignition switch key positions II (IGNITION) and III (ENGINE CRANK).

The suffix E indicates engine management switched power. Power is supplied in ignition switch key positions II (IGNITION) and III (ENGINE CRANK) under ECM control.

### **Ignition Switched Ground**

This symbol represents an ignition switched ground and refers the user to Figure 02.1.

This symbol without a suffix indicates CRANK. Ground is completed in ignition switch key position III (ENGINE CRANK).

The suffix I indicates auxiliary ground. Ground is completed in ignition switch key positions I (AUXILIARY) and II (IGNITION).

The suffix II indicates ignition ground. Ground is completed in ignition switch key positions II (IGNITION) and III (ENGINE CRANK).

### **Figure Number Reference Flag**

This symbol refers the reader to a figure number only. It does not refer to a flag with the same number on a different figure.

As used in Figures 01.1 through 02.1, the reference flag refers the user to a continuation of the circuit. In this instance, the user matches the number to a Power Supply or Ground symbol to trace the circuit.

In most other cases, it is not necessary to refer to another figure for completion of a circuit, as the reference flags are used to indicate parallel circuits and circuits that share components. Most of the circuits where this situation occurs are overlapped to avoid the necessity for cross-referencing to another figure. Exceptions to this rule are instances where signals are transmitted to or received from other system circuits. When circuits are not overlapped, they are noted by (CIRCUIT CONTINUED).

**BPM** Because the Body Processor Module appears numerous times, the abbreviation BPM is used in the reference flags on Figures 01.2 and 02.1 in order to conserve space.

## Control Module Input, Output, Data Link, Signal Ground and Network(s)

 Input

 Sensor Supply V

 ACP

 SCP

 Output

 Sensor Ground

 CAN

 Serial and Encoded Data

These six symbols are employed to assist the user in visualizing the 'logic' of circuits containing control modules. The symbols identify control module input, output, data link, signal ground and network pins. These symbols are also employed on the corresponding data page.



### Wiring Symbols

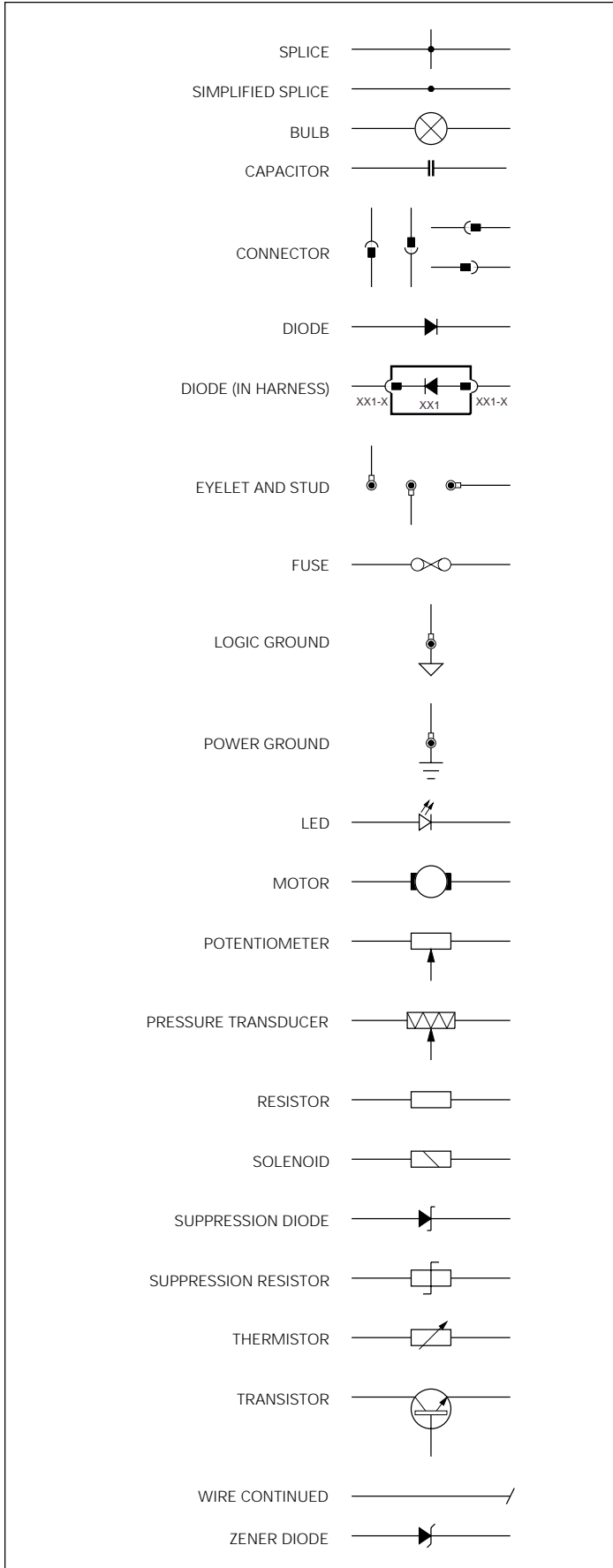

### Wiring Color Codes

N	Brown	O	Orange
B	Black	S	Slate
W	White	L	Light
K	Pink	U	Blue
G	Green	P	Purple
R	Red	BRD	Braid
Y	Yellow		

When a wire has two color code letters, the first letter indicates the main color and the subsequent letter indicates the tracer color.

### Wiring Harness Codes

Code	Description
AC	Air Conditioning (Climate Control)
AN	Generator Suppression Module
AS	Generator to Starter
BB	Trunk Bridging Link
BC	Main Power Distribution
BL	Trunk Lid
BT	Trunk
DD	Door, Driver
DP	Door, Passenger
EL	Engine Management Speed Control Link
EM	Engine Management
EN	Engine Management Side Marker Link
FC	Fascia
FL	LH Front Wheel
FR	RH Front Wheel
IC	In-Car Entertainment
IS	Inclination Sensor Link
LF	Left Forward
LL	Power Steering Link
PI	Engine
QL	Convertible LH Quarter Light Link
QR	Convertible RH Quarter Light Link
RF	Roof
RH	Rearward
RL	LH Rear Wheel
RR	RH Rear Wheel
RT	Radio Telephone
SA	Starter to Generator Link
SC	Column Switchgear
SD	Seat, Driver
SP	Seat, Passenger
SW	Steering Wheel
TL	Telephone

### Code Numbering

When numbering connectors, grounds and splices, Jaguar Engineering uses a three-position format: AC001, AC002, etc. Because space is limited in this Electrical Guide, the codes have been shortened. Thus AC001-001 becomes AC1-1, AC002-001 becomes AC2-1, etc.



## Harness Component Numbers

### Connectors

HARNESS CODE + CONNECTOR NUMBER + PIN NUMBER

EXAMPLE: FC7-24 (pin number is separated by a dash)

Where the pin number differs from LHD to RHD, the connector number will be further identified by (LHD) or (RHD).

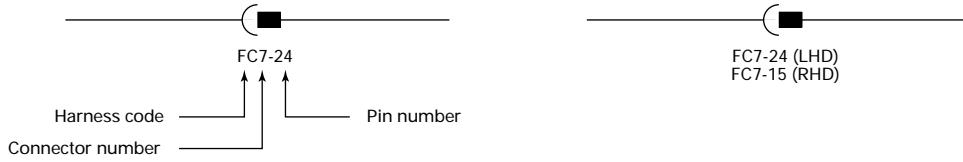

### Splices

HARNESS CODE + S (SPLICE) + SPLICE NUMBER

EXAMPLE: RHS3 (no dash is used)

NOTE: In order to avoid unnecessary circuit complication, multiple splices (more than two wires) within components, in wires leading from input components to multiple circuits and in harness 'ground' sides, are simplified so as not to show wires from other circuits.

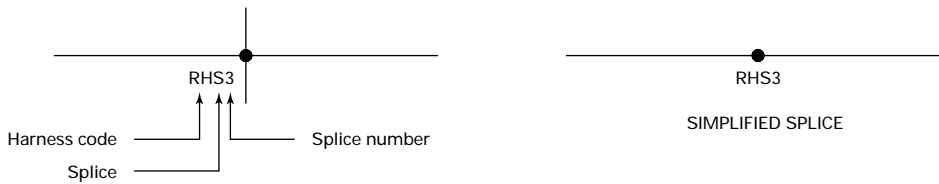

### Diodes

Harness diodes occur at connectors and are depicted as components and identified by a connector number.

EXAMPLE:



### Relay Connectors

Relay connector numbers are shown within the relay. The connector number is shown in the upper portion of the relay; the pin (terminal) number is shown adjacent to the pin. Certain relays are paired and share a modular connector. In this instance, the connector number remains the same for both relays while the pin numbers of the second relay are identified by numbers 6 – 10.

EXAMPLE:

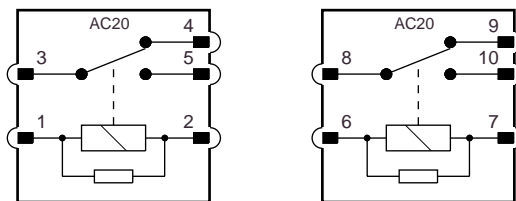





**Grounds**

HARNESS CODE + GROUND STUD NUMBER + EYELET STUD POSITION (A,B,C) + EYELET DESIGNATION (S,L,R)

**Eyelet stud position**

There may be up to three eyelets on one stud. A, B and C are used to indicate the position of the eyelet on the stud: A – first (bottom), B – second (middle), C – third (top).

**Eyelet designation**

Two eyelet variations are used: a single eyelet and an eyelet pair. The single eyelet has a single 'leg', which is identified by an S; the eyelet pair has two 'legs', identified as L (left) or R (right).



SINGLE EYELET

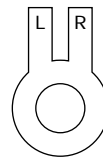

EYELET PAIR

**EXAMPLES:**

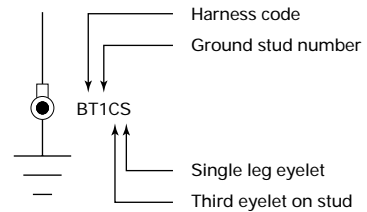
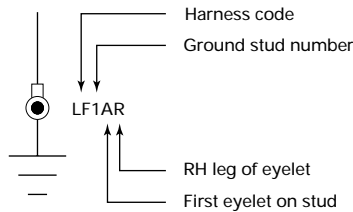
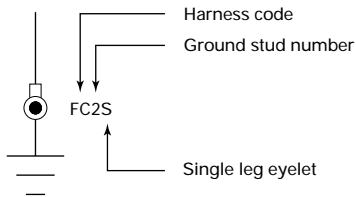

Where the ground designation differs from LHD to RHD, the RHD ground is shown in parentheses. If the ground designation is the same for LHD and RHD, only one ground designation is used.

**EXAMPLES:**

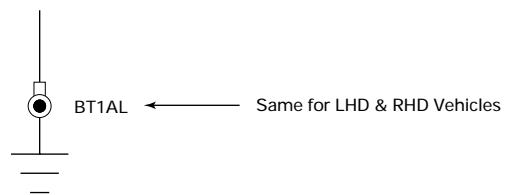
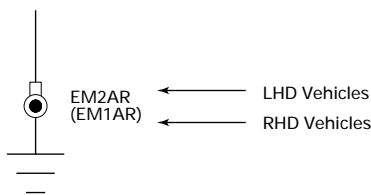



The following connectors are the common harness-to-harness connectors used throughout the vehicle.

**Multilock 040**

Low current (used as harness and 'direct' connection connector).

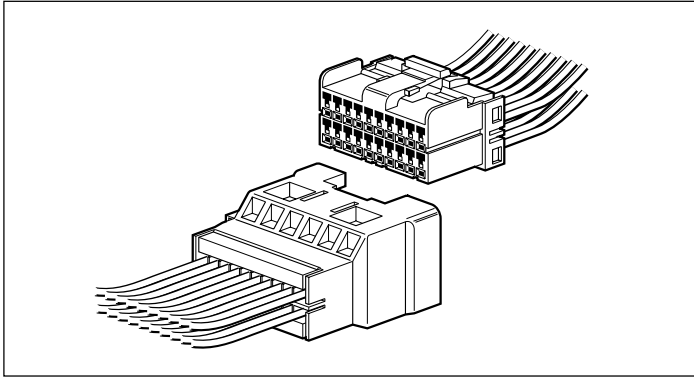
**Multilock 070**

High current (used as harness and 'direct' connection connector).

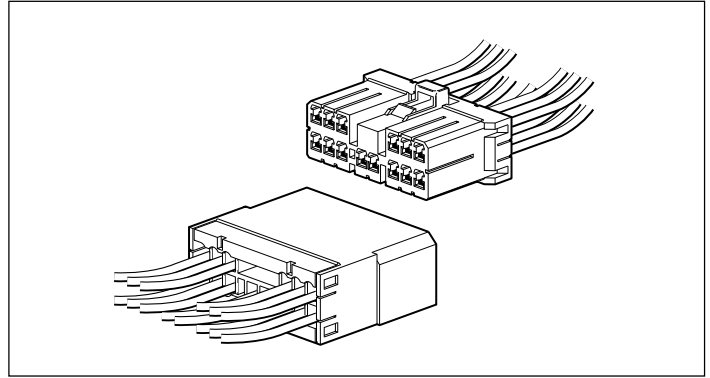
**Econoseal III LC**

Low current sealed connector.

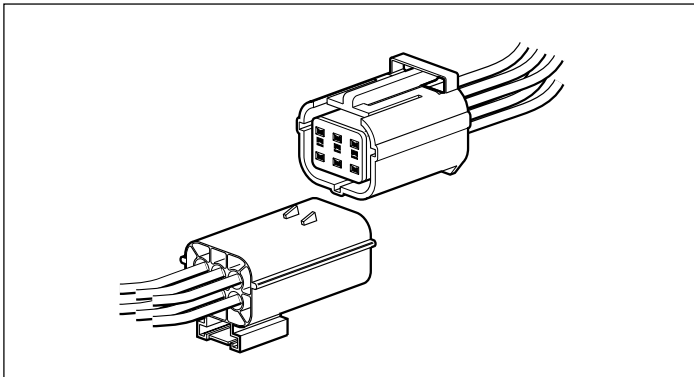
**Econoseal III HC**

High current sealed connector.

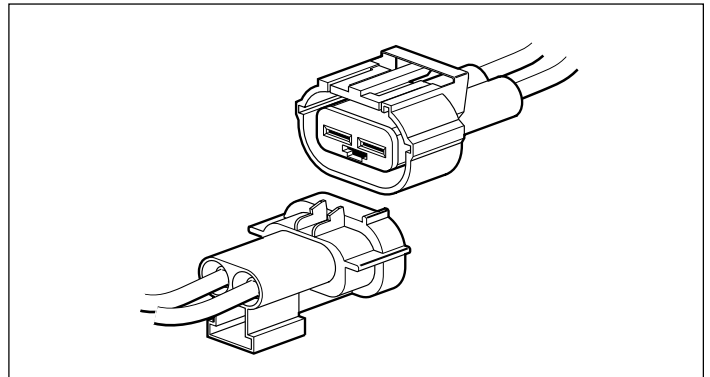
**Ford Card**

Used for SRS only.

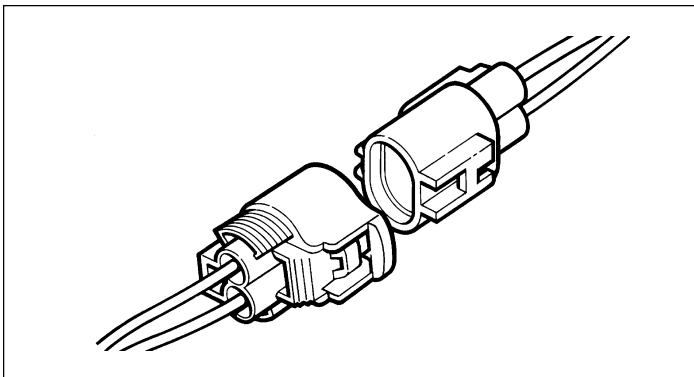

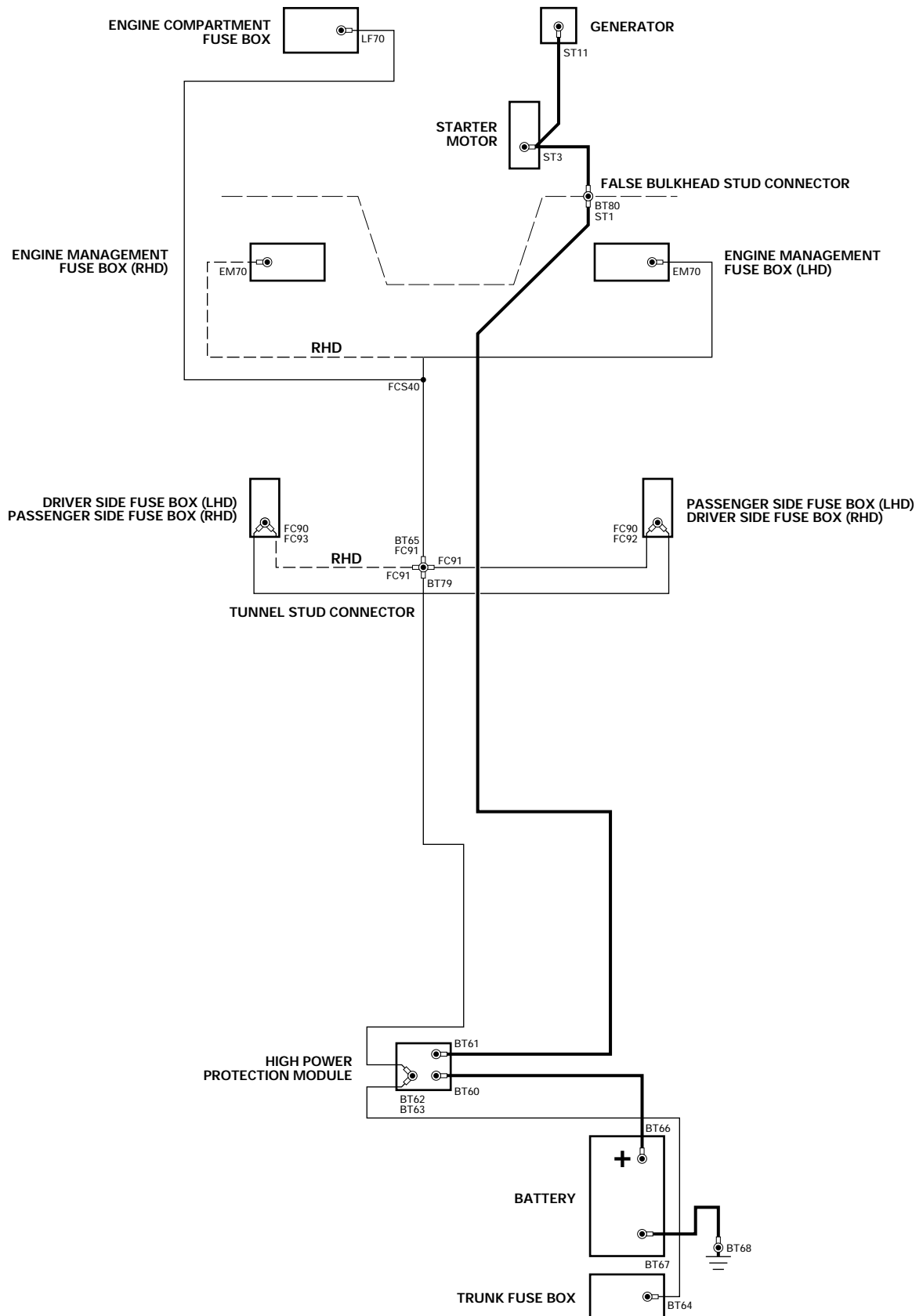



# LHD

FRONT OF VEHICLE

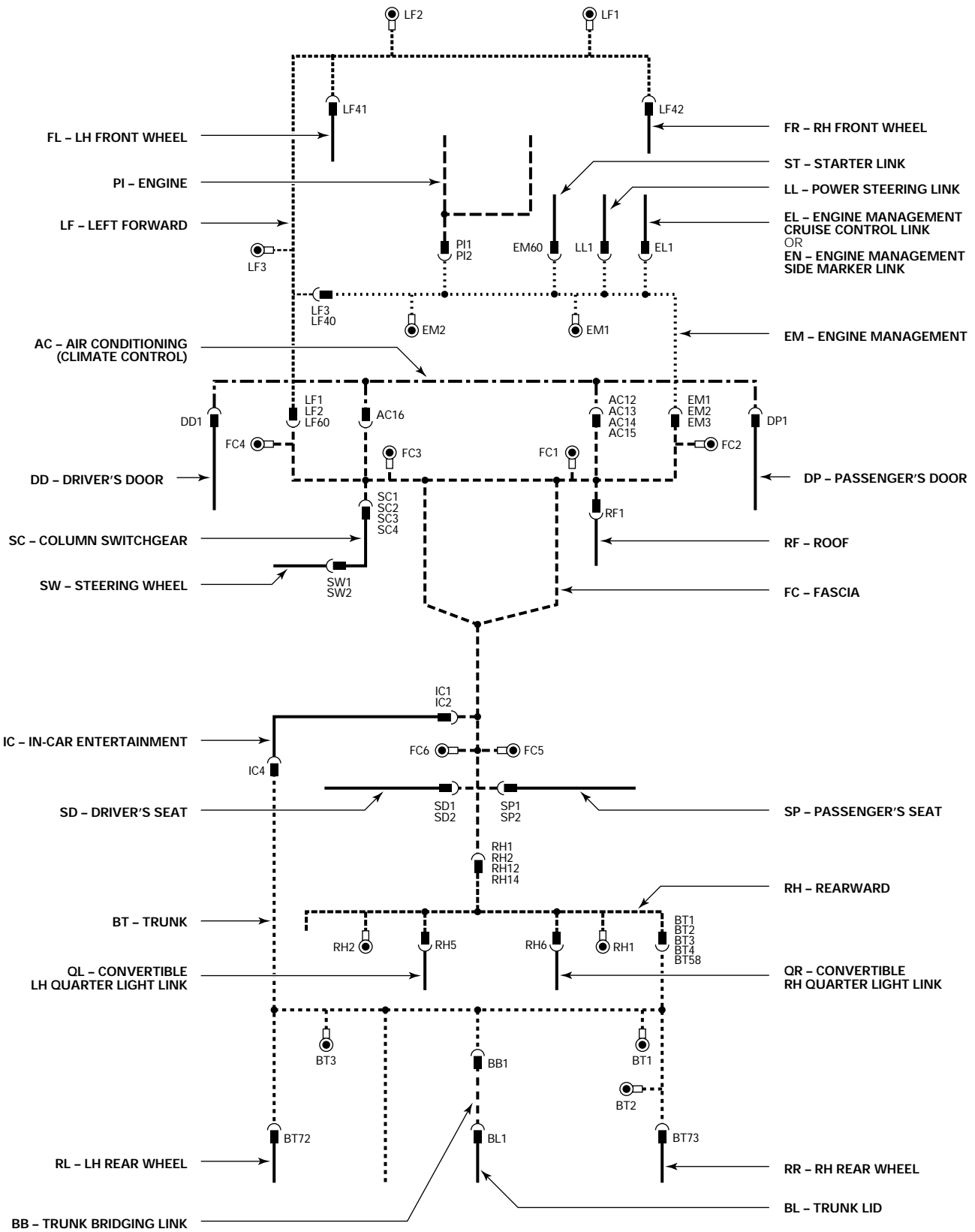



# RHD

FRONT OF VEHICLE

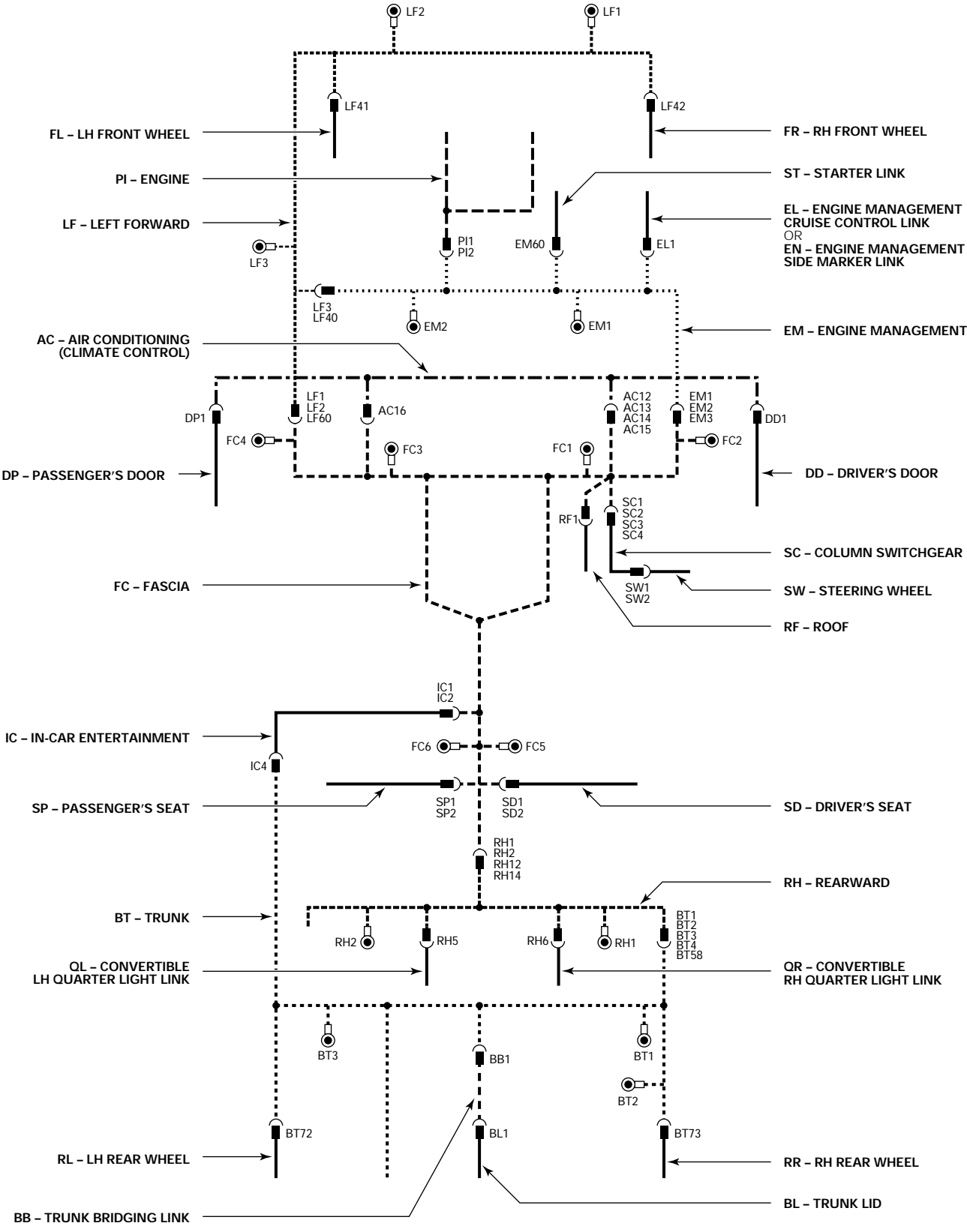

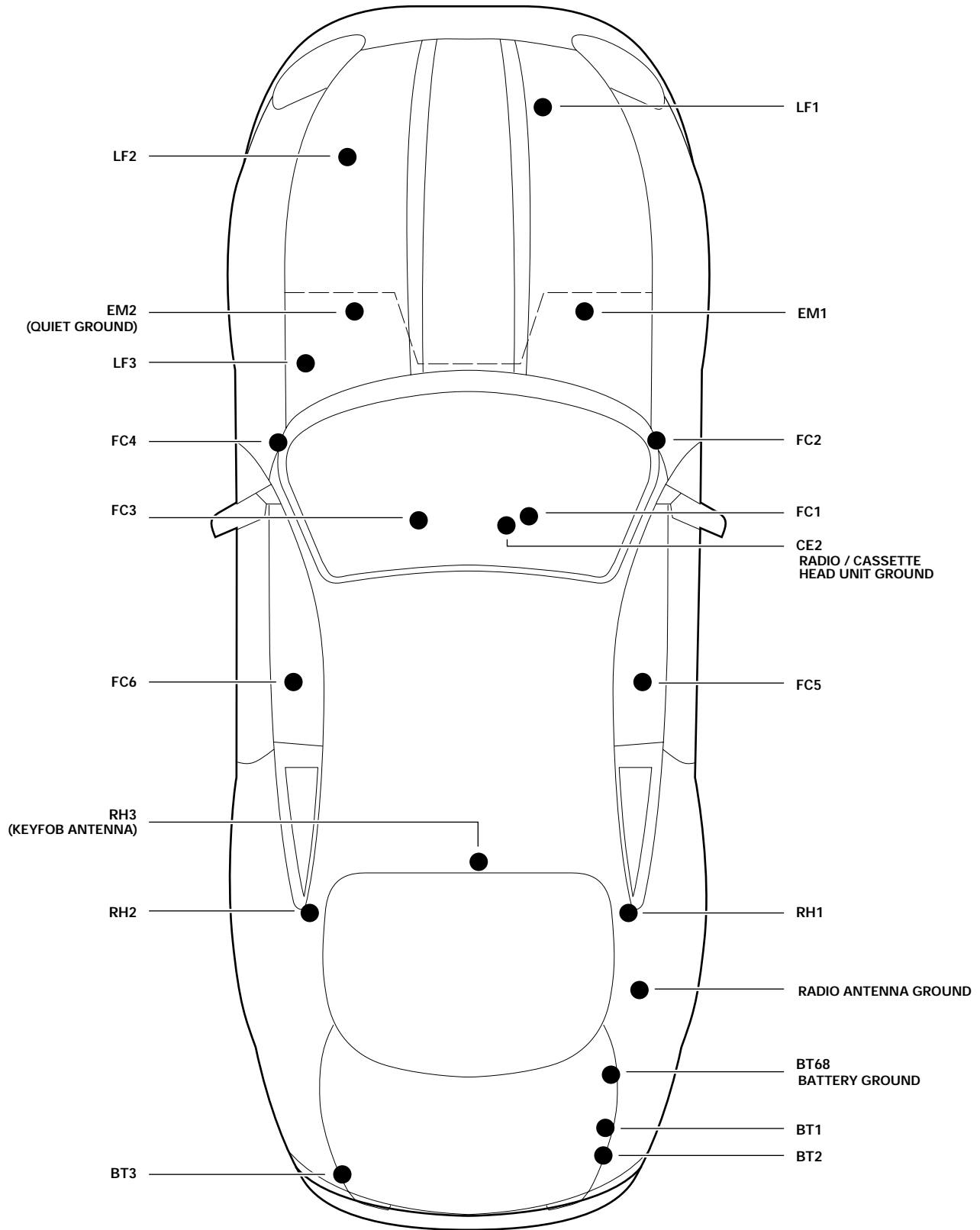

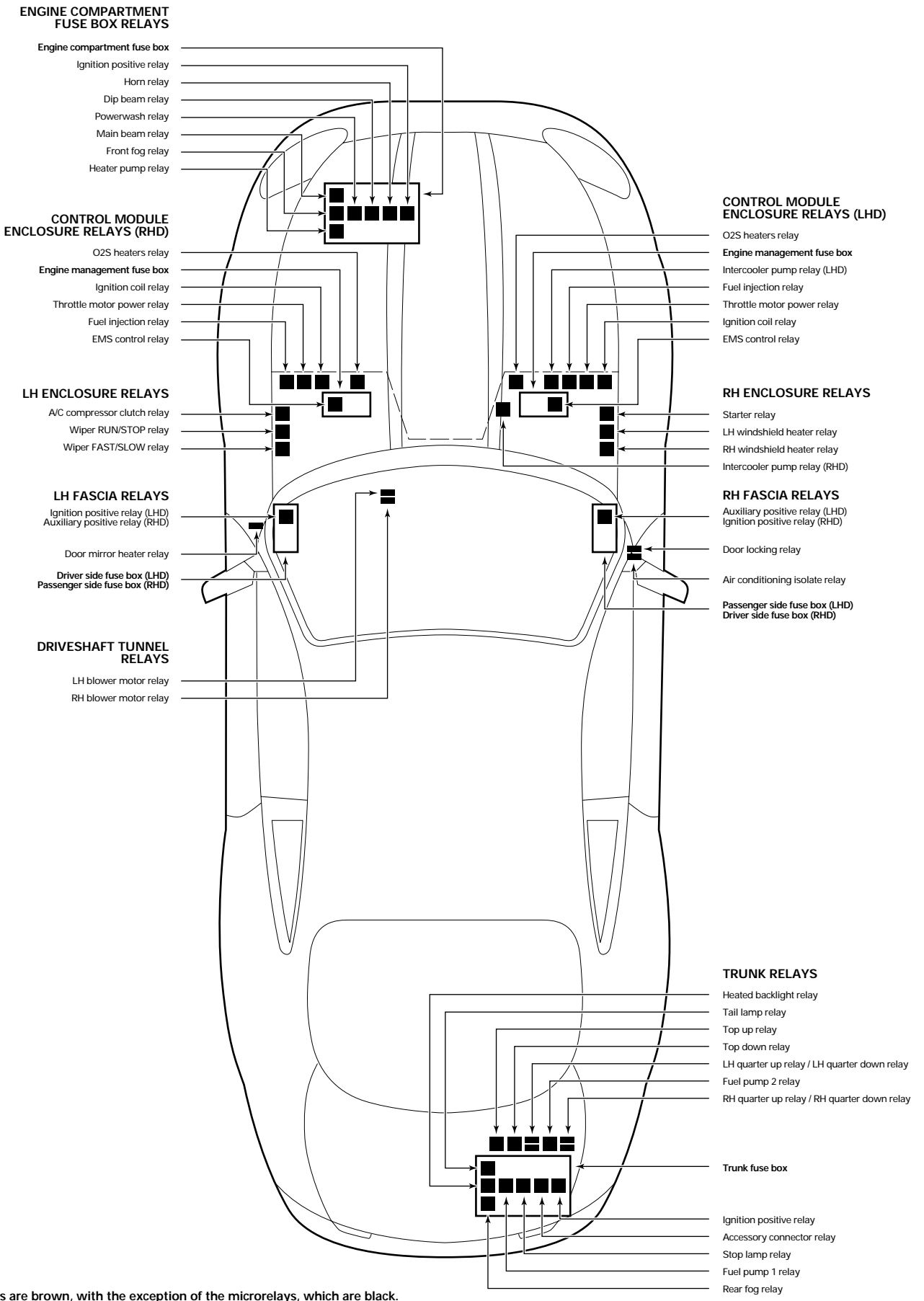

NOTE: All relays are brown, with the exception of the microrelays, which are black.



# LHD

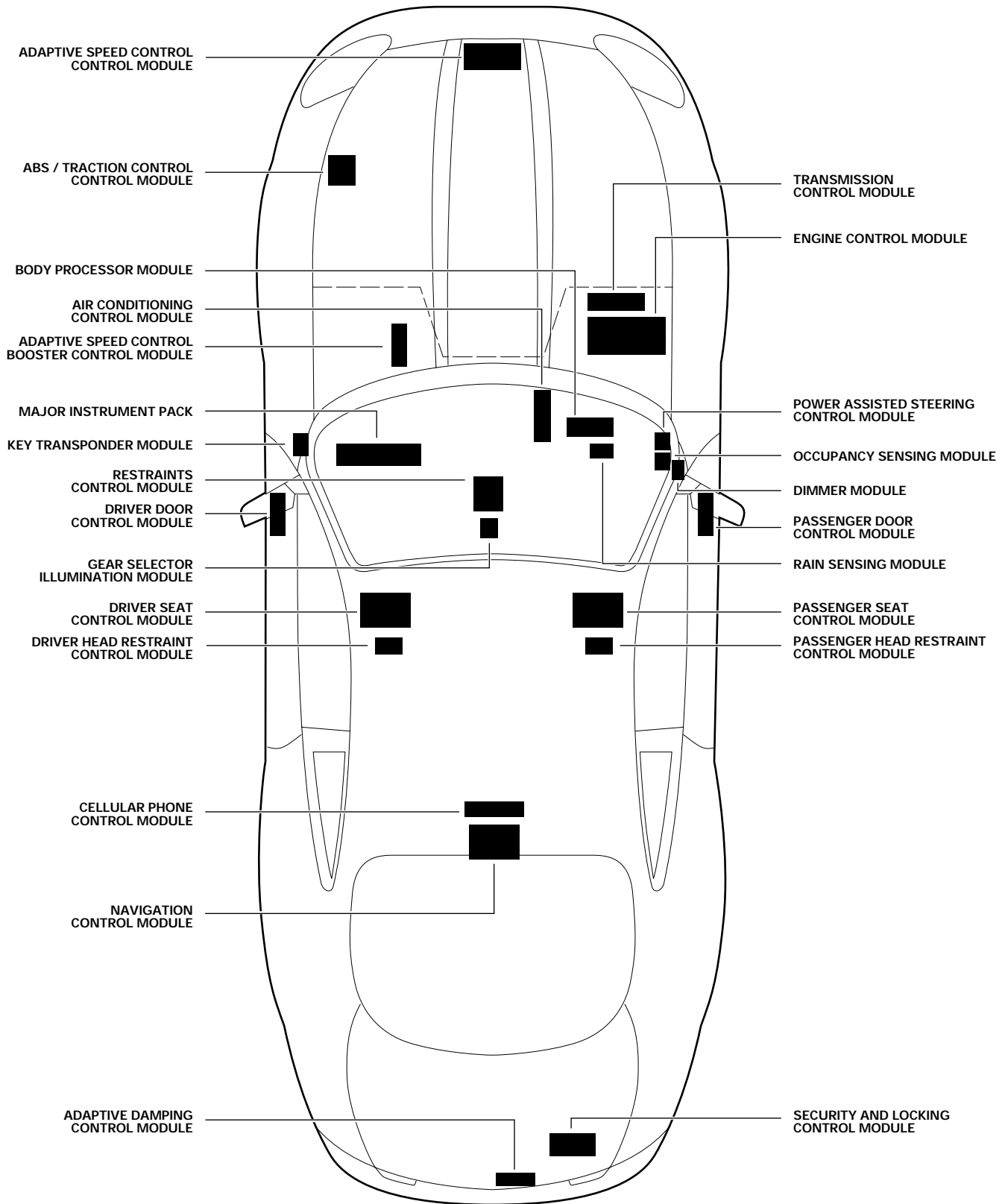





# RHD

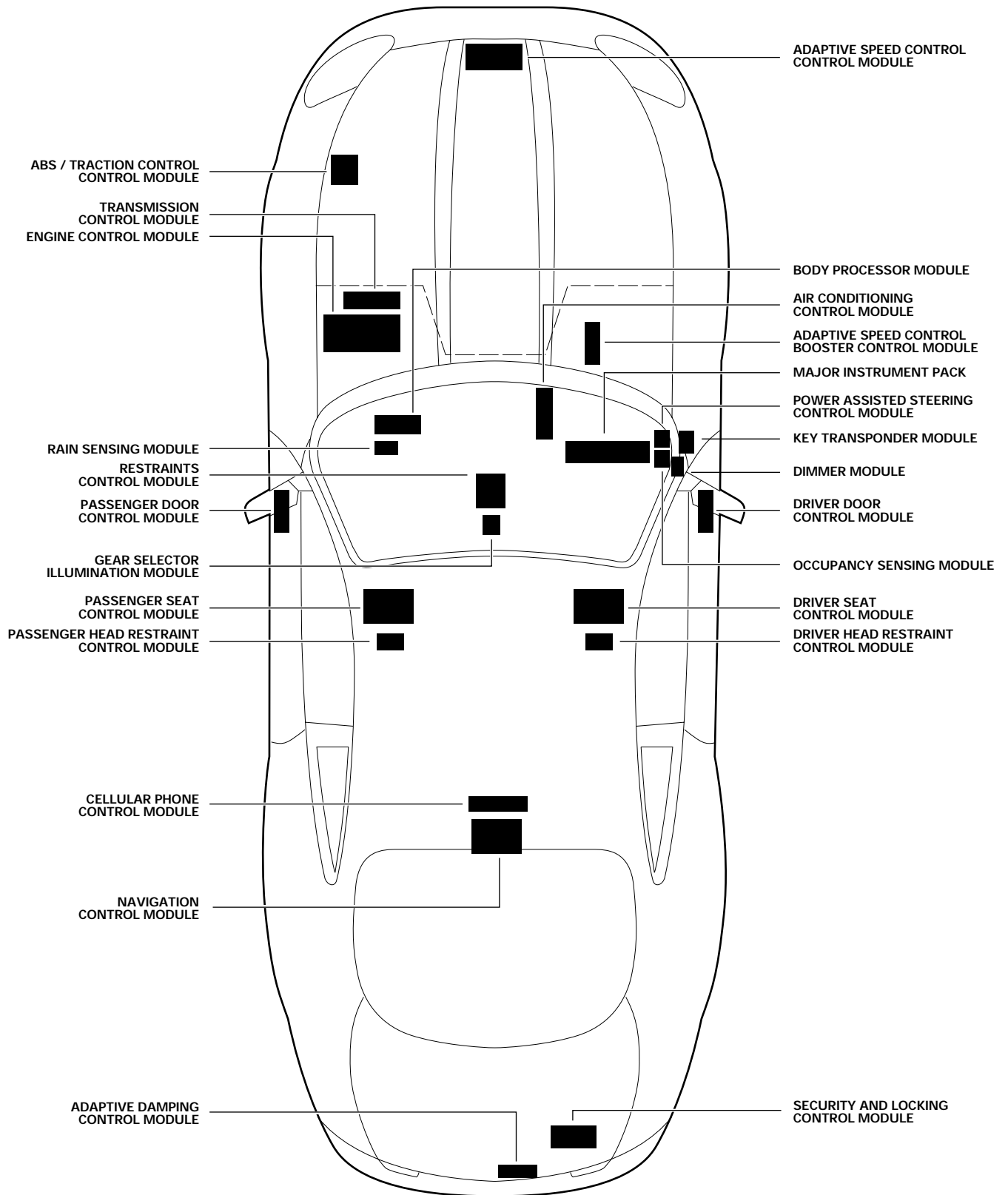



ENGINE CONTROL MODULE: AJ27 N/A

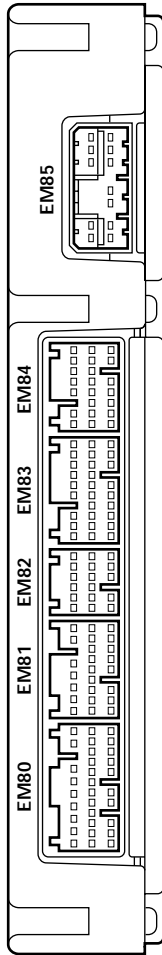

EM80 / 31-WAY / NATURAL

9	GW	8	GW
10	UY	1	UY
11	UY	2	O*
12	UY	3	B
13	YG	4	G
14	YG	5	G
15	YG	6	B
16	YU	7	R
17	O	8	R
18	W	9	R
19	W	10	W
20	U	11	W
21	BK	12	W
22	UY	13	W
23	UY	14	W
24	UY	15	W
25	UY	16	W
26	UY	17	W
27	UY	18	W
28	UY	19	W
29	UY	20	W
30	UY	21	W
31	UY	22	W

EM81 / 24-WAY / NATURAL

7	RG	1	RW
8	OG	2	OY
9	YR	3	WU
10	YR	4	WU
11	YR	5	WU
12	YR	6	WU
13	YR	7	WU
14	YR	8	WU
15	YR	9	WU
16	YR	10	WU
17	YR	11	WU
18	YR	12	WU
19	YR	13	WU
20	YR	14	WU
21	YR	15	WU
22	YR	16	WU
23	YR	17	WU
24	YR	18	WU
25	YR	19	WU
26	YR	20	WU
27	YR	21	WU
28	YR	22	WU
29	YR	23	WU
30	YR	24	WU

EM82 / 17-WAY / NATURAL

6	GR	1	GO
7	G	2	OY
8	N	3	W
9	N	4	W
10	N	5	W
11	N	6	W
12	N	7	W
13	N	8	W
14	N	9	W
15	N	10	W
16	N	11	W
17	N	12	W
18	N	13	W
19	N	14	W
20	N	15	W
21	N	16	W
22	N	17	W

EM83 / 28-WAY / NATURAL

9	N	1	—
10	N	2	—
11	N	3	—
12	N	4	—
13	N	5	—
14	N	6	—
15	N	7	—
16	N	8	—
17	N	9	—
18	N	10	—
19	N	11	—
20	N	12	—
21	N	13	—
22	N	14	—
23	N	15	—
24	N	16	—
25	N	17	—
26	N	18	—
27	N	19	—
28	N	20	—
29	N	21	—
30	N	22	—
31	N	23	—
32	N	24	—
33	N	25	—
34	N	26	—
35	N	27	—
36	N	28	—

EM84 / 22-WAY / NATURAL

7	U	1	—
8	BW	2	—
9	UY	3	—
10	UY	4	—
11	UY	5	—
12	UY	6	—
13	UY	7	—
14	UY	8	—
15	UY	9	—
16	UY	10	—
17	UY	11	—
18	UY	12	—
19	UY	13	—
20	UY	14	—
21	UY	15	—
22	UY	16	—
23	UY	17	—
24	UY	18	—
25	UY	19	—
26	UY	20	—
27	UY	21	—
28	UY	22	—

\* Not used - ROW Vehicles.

EM85 / 12-WAY / WHITE

5	—	1	—
6	—	2	—
7	—	3	—
8	—	4	—
9	—	5	—
10	—	6	—
11	—	7	—
12	—	8	—
13	—	9	—
14	—	10	—
15	—	11	—
16	—	12	—

ENGINE CONTROL MODULE: AJ27 SC

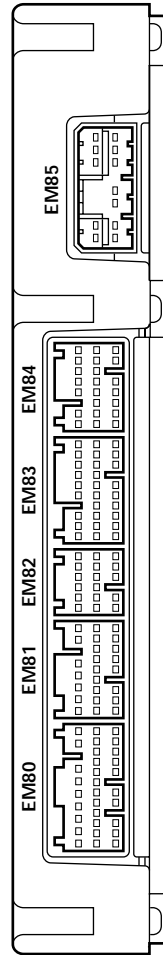

EM80 / 31-WAY / NATURAL

9	GW	8	GW
10	UY	1	UY
11	UY	2	O*
12	UY	3	B
13	YG	4	G
14	YG	5	G
15	YG	6	B
16	YU	7	R
17	O	8	R
18	W	9	R
19	W	10	W
20	U	11	W
21	BK	12	W
22	UY	13	W
23	UY	14	W
24	UY	15	W
25	UY	16	W
26	UY	17	W
27	UY	18	W
28	UY	19	W
29	UY	20	W
30	UY	21	W
31	UY	22	W

EM81 / 24-WAY / NATURAL

7	—	1	—
8	RG	2	—
9	YG	3	—
10	YR	4	—
11	YR	5	—
12	YR	6	—
13	YR	7	—
14	YR	8	—
15	YR	9	—
16	YR	10	—
17	YR	11	—
18	YR	12	—
19	YR	13	—
20	YR	14	—
21	YR	15	—
22	YR	16	—
23	YR	17	—
24	YR	18	—
25	YR	19	—
26	YR	20	—
27	YR	21	—
28	YR	22	—
29	YR	23	—
30	YR	24	—

EM82 / 17-WAY / NATURAL

6	GR	1	GO
7	G	2	OY
8	N	3	W
9	N	4	W
10	N	5	W
11	N	6	W
12	N	7	W
13	N	8	W
14	N	9	W
15	N	10	W
16	N	11	W
17	N	12	W
18	N	13	W
19	N	14	W
20	N	15	W
21	N	16	W
22	N	17	W

EM83 / 28-WAY / NATURAL

9	N	1	—
10	N	2	—
11	N	3	—
12	N	4	—
13	N	5	—
14	N	6	—
15	N	7	—
16	N	8	—
17	N	9	—
18	N	10	—
19	N	11	—
20	N	12	—
21	N	13	—
22	N	14	—
23	N	15	—
24	N	16	—
25	N	17	—
26	N	18	—
27	N	19	—
28	N	20	—
29	N	21	—
30	N	22	—
31	N	23	—
32	N	24	—
33	N	25	—
34	N	26	—
35	N	27	—
36	N	28	—

EM84 / 22-WAY / NATURAL

7	U	1	—
8	BW	2	—
9	UY	3	—
10	UY	4	—
11	UY	5	—
12	UY	6	—
13	UY	7	—
14	UY	8	—
15	UY	9	—
16	UY	10	—
17	UY	11	—
18	UY	12	—
19	UY	13	—
20	UY	14	—
21	UY	15	—
22	UY	16	—
23	UY	17	—
24	UY	18	—
25	UY	19	—
26	UY	20	—
27	UY	21	—
28	UY	22	—

\* Not used - ROW Vehicles.

EM85 / 12-WAY / WHITE

5	—	1	—
6	—	2	—
7	—	3	—
8	—	4	—
9	—	5	—
10	—	6	—
11	—	7	—
12	—	8	—
13	—	9	—
14	—	10	—
15	—	11	—
16	—	12	—





ABS / TRACTION CONTROL CONTROL MODULE

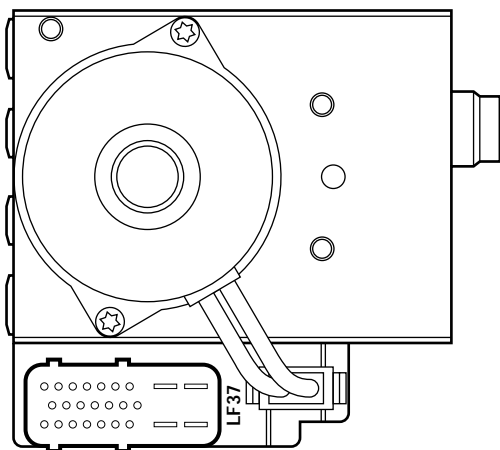

LF37 / 25-WAY / BLACK

1	UY	17	W
2	OG	18	R
3	Y	19	O
4	G	20	WU
5	Y	21	W
6	R	22	U
7	O	23	—
8	B	24	B
9	NR	25	NW

ADAPTIVE DAMPING CONTROL MODULE

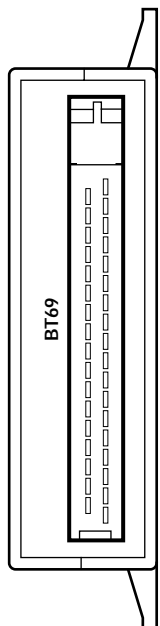

BT69 / 35-WAY / BLACK

1	YR	2	—	3	OY	4	—	5	—	6	—	7	—	8	—	9	—	10	O	11	WR	12	—	13	R	14	OG	15	OG	16	—	17	—	18	B
19	—	20	BC	21	U	22	R	23	—	24	OG	25	U	26	OG	27	NW	28	W	29	—	30	O	31	OY	32	O	33	GU	34	OY	35	—		





MAJOR INSTRUMENT PACK

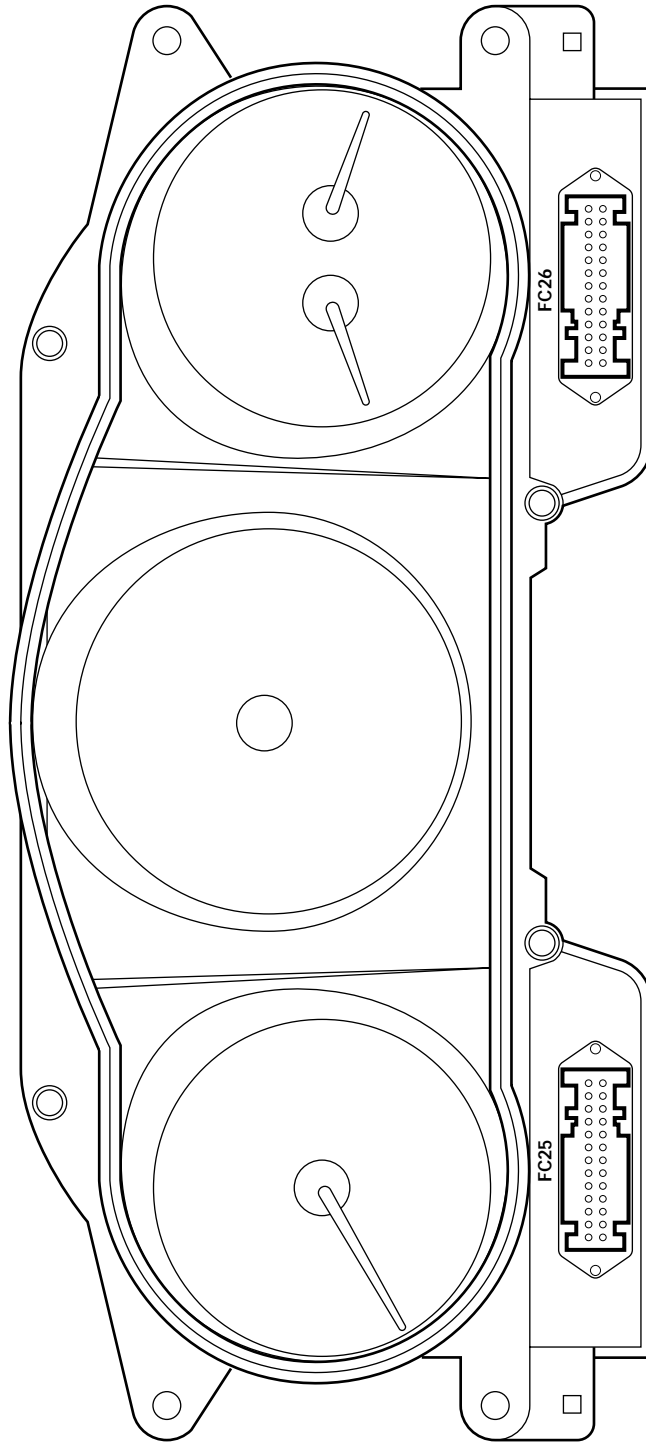

FC25 / 26-WAY / BLACK

1	WG	2	RG	3	YR	4	BK	5	—	6	RU	7	YB	8	UY	9	R	10	Y	11	Y	12	—	13	Y
14	U	15	R	16	B	17	RW	18	Y	19	O	20	—	21	—	22	—	23	G	24	G	25	BR	26	—

FC26 / 26-WAY / YELLOW

1	RW	2	RW	3	RW	4	YG	5	OY	6	U	7	OG	8	RG	9	Y	10	O	11	G	12	RU	13	BW
14	RW	15	UY	16	Y	17	OY	18	G	19	G	20	OG	21	RG	22	Y	23	OG	24	—	25	—	26	—



BODY PROCESSOR MODULE

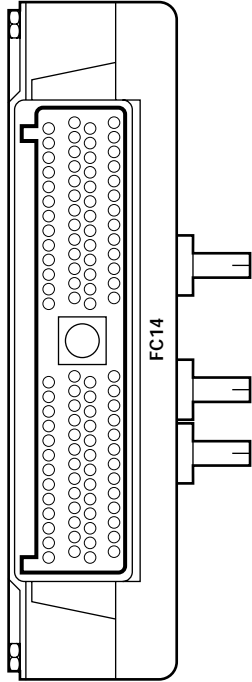

FC14 / 104-WAY / GREY

79	80	81	82	83	84	85	86	87	88	89	90	91	92	93	94	95	96	97	98	99	100	101	102	103	104	
NG	N	GR	GR	GB	U	Y	OG	Y	YG	GR	BG	BW	YB	Y	G	RU	N	WG	GB	UY	BR	RW	N	—	—	
53	54	55	56	57	58	59	60	61	62	63	64	65	66	67	68	69	70	71	72	73	74	75	76	77	78	
R	G	YU	OY	—	YB	Y	RW	WG	GU	Y	—	—	RU	O	OG	YR	—	GO	YR	—	GO	RW	—	GO	GU	U
27	28	29	30	31	32	33	34	35	36	37	38	39	40	41	42	43	44	45	46	47	48	49	50	51	52	
GO	RW	Y	U	Y	WR	RG	GO	G	GW	GR	RU	Y	WU	RW	UY	BG	U	U	—	—	OG	—	GW	RW	BW	
1	2	3	4	5	6	7	8	9	10	11	12	13	14	15	16	17	18	19	20	21	22	23	24	25	26	
BG	GW	W	GU	YR	Y	RU	BW	GU	YR	YB	W	GO	O	WU	RW	OY	YB	WG	OG	—	WB	WU	NW	B	YG	

SECURITY AND LOCKING CONTROL MODULE

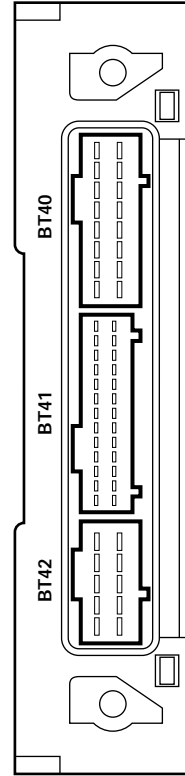

BT42 / 10-WAY / BLACK

5	4	3	2	1
RU	RU	RG	U	OY
10	9	8	7	6
R	RW	R	UY	O

BT41 / 26-WAY / BLACK

13	12	11	10	9	8	7	6	5	4	3	2	1
RW	RW	—	BK	—	GW	YU	RU	RW	—	GW*	—	—
26	25	24	23	22	21	20	19	18	17	16	15	14
YR	—	—	—	—	—	YR	—	—	—	—	—	—

BT40 / 16-WAY / BLACK

8	7	6	5	4	3	2	1
Y	OG	NR	Y	GW*	U*	O	O
16	15	14	13	12	11	10	9
U	NW	BK	BK	—	—	UY*	GR*

KEY TRANSPONDER MODULE

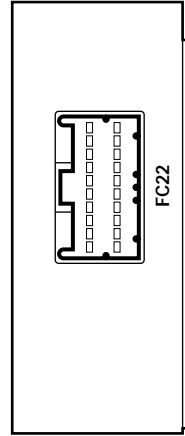

FC22 / 20-WAY / GREEN

10	9	8	7	6	5	4	3	2	1
—	YB	OG	O	O	—	NR	—	—	YB
20	19	18	17	16	15	14	13	12	11
—	—	—	Y	O	—	WU	WR	BK	—

\* Not used - COUPE Vehicles.



RESTRAINTS CONTROL MODULE

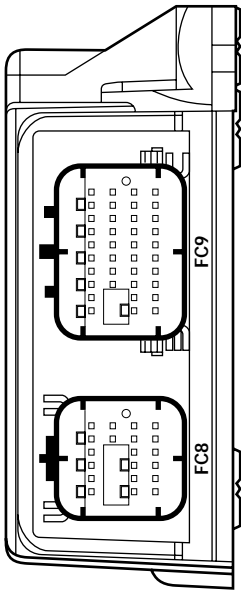

FC8 / 24-WAY / BLACK

1	WR	RU	3	RW	4	BW	5	INW	6	NG	11	12	O	W	
13	14	15	16	17	18	19	20	21	22	23	24	27	28	29	30
RW	BW	Y	BK	—	—	—	—	—	—	—	—	—	—	—	—
19	20	21	22	23	24	27	28	29	30	31	32	33	34	35	36
YB	OG	OG	BW	—	—	—	—	—	—	—	—	—	—	—	—

FC9 / 40-WAY / BLACK

1	2	3	4	5	6	7	8	9	10
—	—	—	—	—	—	—	—	—	—
13	14	15	16	17	18	19	20	21	22
UY	OY	BW	RW	YU	YG	W	G	WU	GU
31	32	33	34	35	36	37	38	39	40
RW	BW	RW	BW	—	—	—	—	—	—

(RHD)

27	28	29	30
WU	GU	W	G

FC10 / 26-WAY / YELLOW

14	15	16	17	18	19	20	21	22	23	24	25	26
—	—	—	—	—	—	—	—	—	—	—	—	—
1	2	3	4	5	6	7	8	9	10	11	12	13
W	G	W	Y	W	U	N	G	—	—	U	O	—

OCCUPANCY SENSING MODULE

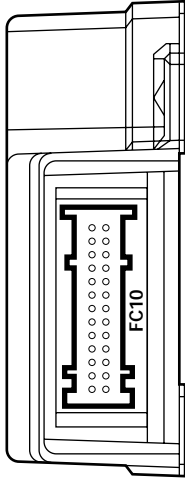

DRIVER DOOR CONTROL MODULE

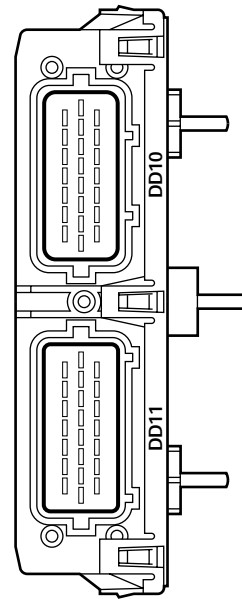

DD11 / 22-WAY / BLACK

7	6	5	4	3	2	1	
BR	WU	GU	NG	YR	U	NR	
15	14	13	12	11	10	9	8
WG	—	—	OY	—	WB	Y	BK
21	20	19	18	17	16	—	—
UY	O	GW	—	—	O	—	—

DD10 / 22-WAY / BLUE

7	6	5	4	3	2	1	
O	YB	Y	UY	U	BW	N	
15	14	13	12	11	10	9	8
OY	GW	UY	RW	U	BG	U	BK
22	21	20	19	18	17	16	15
OG	RU	WU	GB	BO	B	Y	—

PASSENGER DOOR CONTROL MODULE

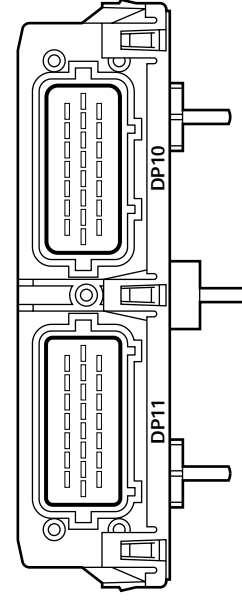

DP11 / 22-WAY / BLACK

7	6	5	4	3	2	1	
—	—	GU	—	—	—	—	
15	14	13	12	11	10	9	8
—	—	—	—	—	—	—	—
22	21	20	19	18	17	16	15
—	—	GW	—	—	—	—	—

DP10 / 22-WAY / BLUE

7	6	5	4	3	2	1	
O	YB	Y	UY	U	BW	N	
15	14	13	12	11	10	9	8
OY	GW	UY	RW	U	BG	U	BK
22	21	20	19	18	17	16	15
OG	RU	WU	—	BO	B	Y	—





DRIVER HEAD RESTRAINT CONTROL MODULE

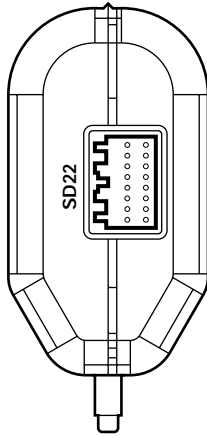

SD22 / 16-WAY / BLACK

8	7	6	5	4	3	2	1
B	B	G	UY	RU	OG	—	N
16	15	14	13	12	11	10	9
BW	BG	Y	U	YU	W	WG	NG

PASSENGER HEAD RESTRAINT CONTROL MODULE

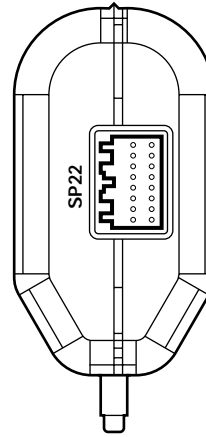

SP22 / 16-WAY / BLACK

8	7	6	5	4	3	2	1
—	B	G	UY	RU	OG	—	N
16	15	14	13	12	11	10	9
BW	BG	Y	U	YU	W	WG	NG

DRIVER SEAT CONTROL MODULE

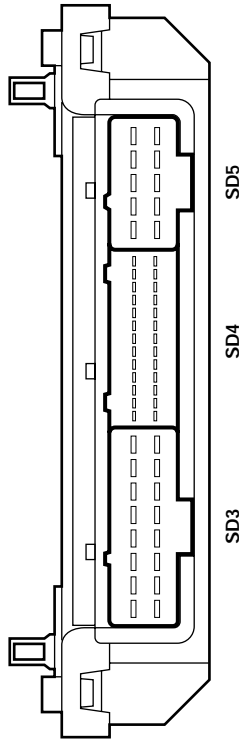

SD3 / 16-WAY / BLACK

9	10	11	12	13	14	15	16
UY	OY	W	WG	GU	GR	GW	NR
1	2	3	4	5	6	7	8
GO	BG	O	R	G	GR	WU	WR

SD4 / 26-WAY / BLACK

14	15	16	17	18	19	20	21	22	23	24	25	26
WU	YG	—	—	WR	YB	—	—	—	—	—	—	—
1	2	3	4	5	6	7	8	9	10	11	12	13
WG	BG	—	—	W	WB	—	Y	—	WR	W	BO	—

SD5 / 10-WAY / BLACK

6	7	8	9	10
—	—	G	Y	U
1	2	3	4	5
BO	B	OG	UY	NR

PASSENGER SEAT CONTROL MODULE

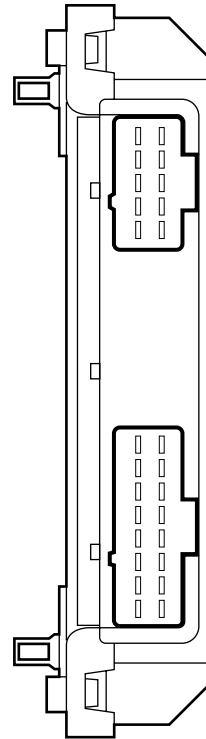

SP3 / 16-WAY / BLACK

9	10	11	12	13	14	15	16
UY	OY	W	WG	W	WG	GW	NR
1	2	3	4	5	6	7	8
GO	NG	O	R	G	GR	WU	WR

SP5 / 10-WAY / BLACK

6	7	8	9	10
—	—	G	Y	U
1	2	3	4	5
—	B	OG	OY	NR

# Fig. 01.1

## COMPONENTS

Component	Connector / Type / Color	Location / Access
BATTERY	BT66 / EYELET	TRUNK, RIGHT HAND SIDE
BODY PROCESSOR MODULE	BT67 / EYELET	
FUSE BOX - DRIVER SIDE	FC14 / 104-WAY AMP EEEC / GREY FC5 / 10-WAY U.T.A. FUSEBOX / NATURAL FC6 / 10-WAY U.T.A. FUSEBOX / BLACK FC90 / EYELET FC92 / EYELET FC94 / EYELET	PASSENGER SIDE FASCIA / AIRBAG BRACKET FASCIA / DRIVER SIDE
FUSE BOX - ENGINE COMPARTMENT	LF5 / 10-WAY U.T.A. FUSEBOX / NATURAL LF6 / 10-WAY U.T.A. FUSEBOX / BLACK LF7 / 10-WAY U.T.A. FUSEBOX / GREEN LF8 / 10-WAY U.T.A. FUSEBOX / BLUE LF70 / EYELET	ENGINE COMPARTMENT / LEFT FRONT
FUSE BOX - ENGINE MANAGEMENT	EM19 / 10-WAY U.T.A. FUSEBOX / NATURAL EM20 / 10-WAY U.T.A. FUSEBOX / BLACK EM70 / EYELET	ENGINE COMPARTMENT / CONTROL MODULE ENCLOSURE
FUSE BOX - PASSENGER SIDE	FC20 / 10-WAY U.T.A. FUSEBOX / NATURAL FC21 / 10-WAY U.T.A. FUSEBOX / BLACK FC90 / EYELET FC93 / EYELET	FASCIA / PASSENGER SIDE
FUSE BOX - TRUNK	BT10 / 10-WAY U.T.A. FUSEBOX / NATURAL BT11 / 10-WAY U.T.A. FUSEBOX / BLACK BT12 / 10-WAY U.T.A. FUSEBOX / GREEN BT13 / 10-WAY U.T.A. FUSEBOX / BLUE BT64 / EYELET	TRUNK / ELECTRICAL CARRIER
HIGH POWER PROTECTION MODULE	BT60 / EYELET BT61 / EYELET BT62 / EYELET BT63 / EYELET	TRUNK / ADJACENT TO BATTERY
TRANSIT ISOLATION DEVICE	BT44 / 2-WAY ECONOSEAL III HC / BLACK BT49 / 1-WAY LUCAR BT66 / EYELET	TRUNK / ADJACENT TO BATTERY

## RELAYS

Relay	Color / Stripe	Connector / Color	Location / Access
AUXILIARY POSITIVE RELAY	BROWN	BUS	PASSENGER SIDE FUSE BOX
EMS CONTROL RELAY	BROWN	BUS	ENGINE MANAGEMENT FUSE BOX
IGNITION POSITIVE RELAY	BROWN	BUS	DRIVER SIDE FUSE BOX
IGNITION POSITIVE RELAY	BROWN	BUS	ENGINE COMPARTMENT FUSE BOX
IGNITION POSITIVE RELAY	BROWN	BUS	TRUNK FUSE BOX

## HARNESS-TO-HARNESS CONNECTORS

Connector	Type / Color	Location / Access
BT2	20-WAY MULTILOCK 070 / WHITE	TRUNK / ABOVE RIGHT HAND REAR WHEEL ARCH
BT65	EYELET	TRANSMISSION TUNNEL
BT79	EYELET	TRANSMISSION TUNNEL
BT80	EYELET	ENGINE COMPARTMENT / FALSE BULKHEAD, RIGHT HAND SIDE
FC91	EYELET	TRANSMISSION TUNNEL
RH2	20-WAY MULTILOCK 070 / WHITE	REAR OF CENTER CONSOLE ASSEMBLY
ST1	EYELET	ENGINE COMPARTMENT / FALSE BULKHEAD, RIGHT HAND SIDE

## GROUND

Ground	Location / Type
BT68	BATTERY GROUND STUD
BT2BR	EYELET (PAIR) - RIGHT HAND LEG / TRUNK, RIGHT REAR
BT2BS	EYELET (SINGLE) / TRUNK, RIGHT REAR

Refer to the front of this book for detailed information and illustrations regarding the location and identification of harnesses, relays, grounds, control modules and control module pins.

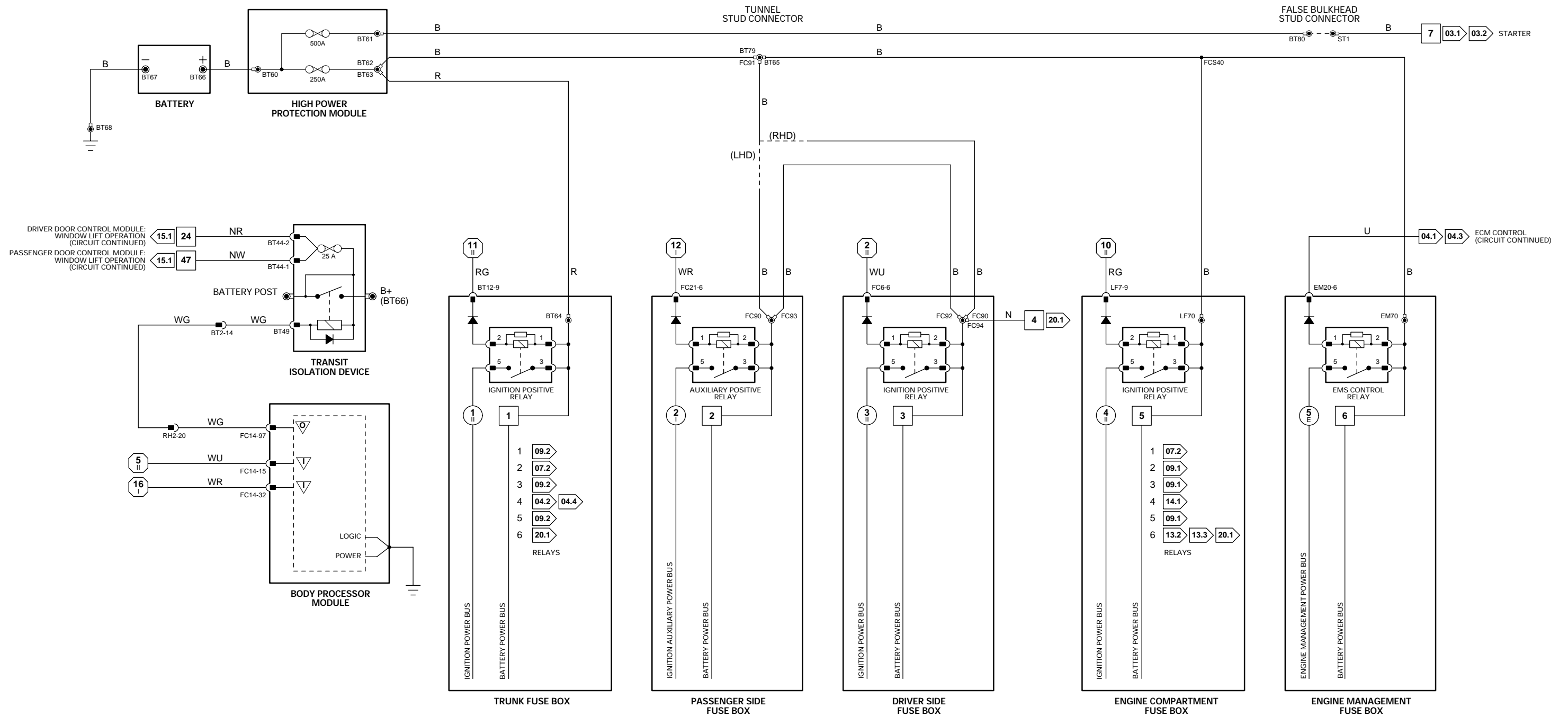

**Fig. 01.2****COMPONENTS****Component**

FUSE BOX – DRIVER SIDE

**Connector / Type / Color**FC5 / 10-WAY U.T.A. FUSEBOX / NATURAL  
FC6 / 10-WAY U.T.A. FUSEBOX / BLACK  
FC90 / EYELET  
FC92 / EYELET  
FC94 / EYELET**Location / Access**

FASCIA / DRIVER SIDE

FUSE BOX – PASSENGER SIDE

FC20 / 10-WAY U.T.A. FUSEBOX / NATURAL  
FC21 / 10-WAY U.T.A. FUSEBOX / BLACK  
FC90 / EYELET  
FC93 / EYELET

FASCIA / PASSENGER SIDE

**HARNESS-TO-HARNESS CONNECTORS****Connector**

AC12

AC13

AC14

AC15

AC16

BT2

BT58

DD1

DP1

IC2

LF1

RF1

RH14

RH2

SD1

SP1

**Type / Color**

20-WAY MULTILOCK 070 / WHITE

20-WAY MULTILOCK 070 / YELLOW

14-WAY MULTILOCK 070 / GREY

20-WAY MULTILOCK 070 / GREY

6-WAY MULTILOCK 070 / YELLOW

20-WAY MULTILOCK 070 / WHITE

4-WAY ECONOSEAL III HC / BLACK

23-WAY AMP – FORD / BLACK

23-WAY AMP – FORD / BLACK

14-WAY MULTILOCK 070 / WHITE

20-WAY MULTILOCK 070 / GREY

24-WAY CONNECTOR / BLACK

2-WAY ECONOSEAL III HC / BLACK

20-WAY MULTILOCK 070 / WHITE

14-WAY MULTILOCK 070 / YELLOW

14-WAY MULTILOCK 070 / YELLOW

**Location / Access**

FASCIA TOP CONNECTOR MOUNTING BRACKET / RIGHT HAND SIDE

FASCIA BOTTOM CONNECTOR MOUNTING BRACKET / RIGHT HAND SIDE

FASCIA BOTTOM CONNECTOR MOUNTING BRACKET / RIGHT HAND SIDE

FASCIA BOTTOM CONNECTOR MOUNTING BRACKET / RIGHT HAND SIDE

LEFT HAND 'A' POST CONNECTOR MOUNTING BRACKET / 'A' POST TRIM

TRUNK / ABOVE RIGHT HAND REAR WHEEL ARCH

TRUNK / ABOVE RIGHT HAND REAR WHEEL ARCH

DRIVER SIDE 'A' POST MOUNTING BRACKET / 'A' POST TRIM

PASSENGER SIDE 'A' POST / 'A' POST TRIM

BELOW CENTER CONSOLE GLOVE BOX

LEFT HAND 'A' POST CONNECTOR MOUNTING BRACKET / 'A' POST TRIM

RIGHT HAND 'A' POST CONNECTOR MOUNTING BRACKET / 'A' POST TRIM

REAR OF CENTER CONSOLE ASSEMBLY

REAR OF CENTER CONSOLE ASSEMBLY

BELOW DRIVER SEAT

BELOW PASSENGER SEAT

Refer to the front of this book for detailed information and illustrations regarding the location and identification of harnesses, relays, grounds, control modules and control module pins.

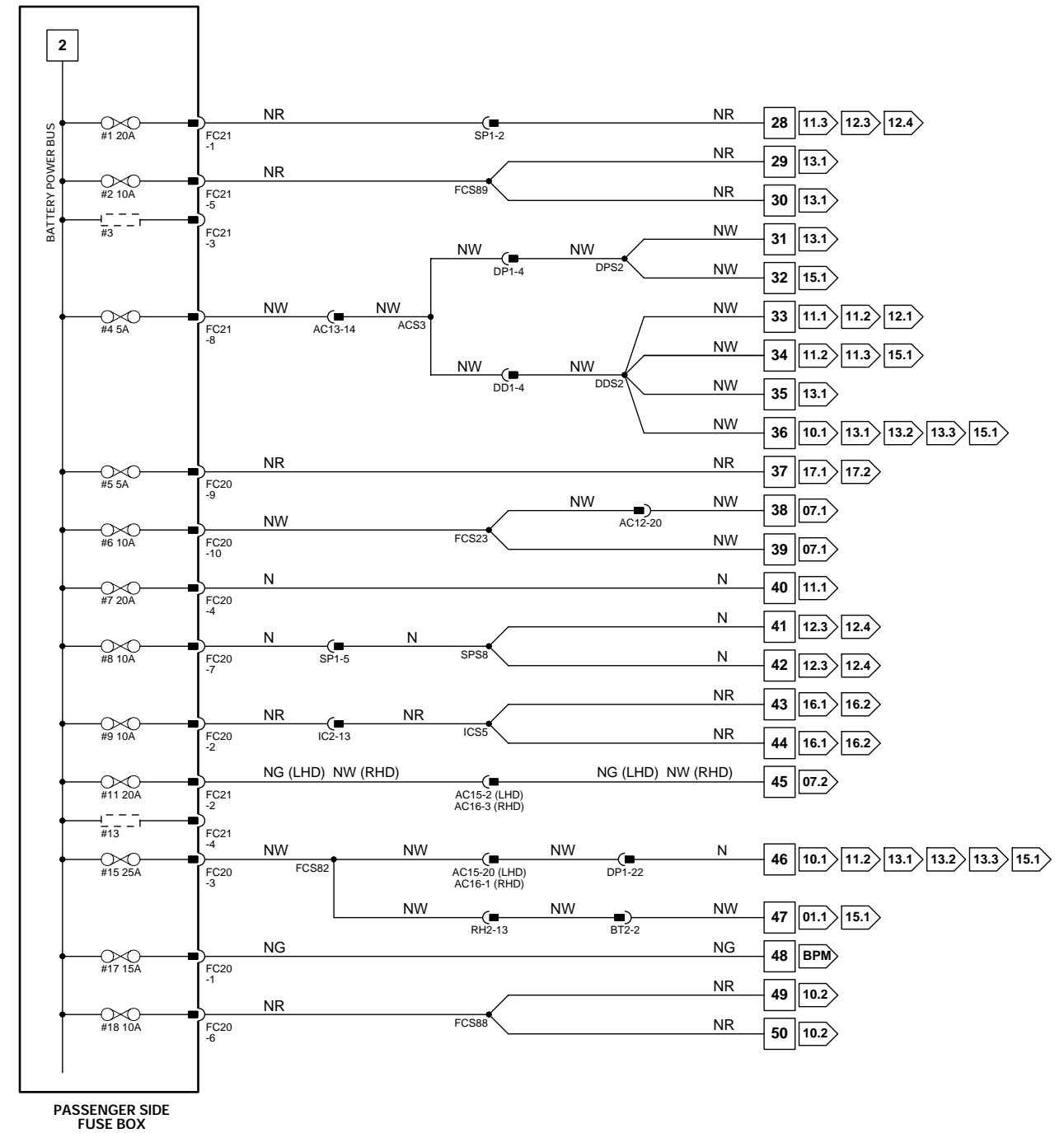
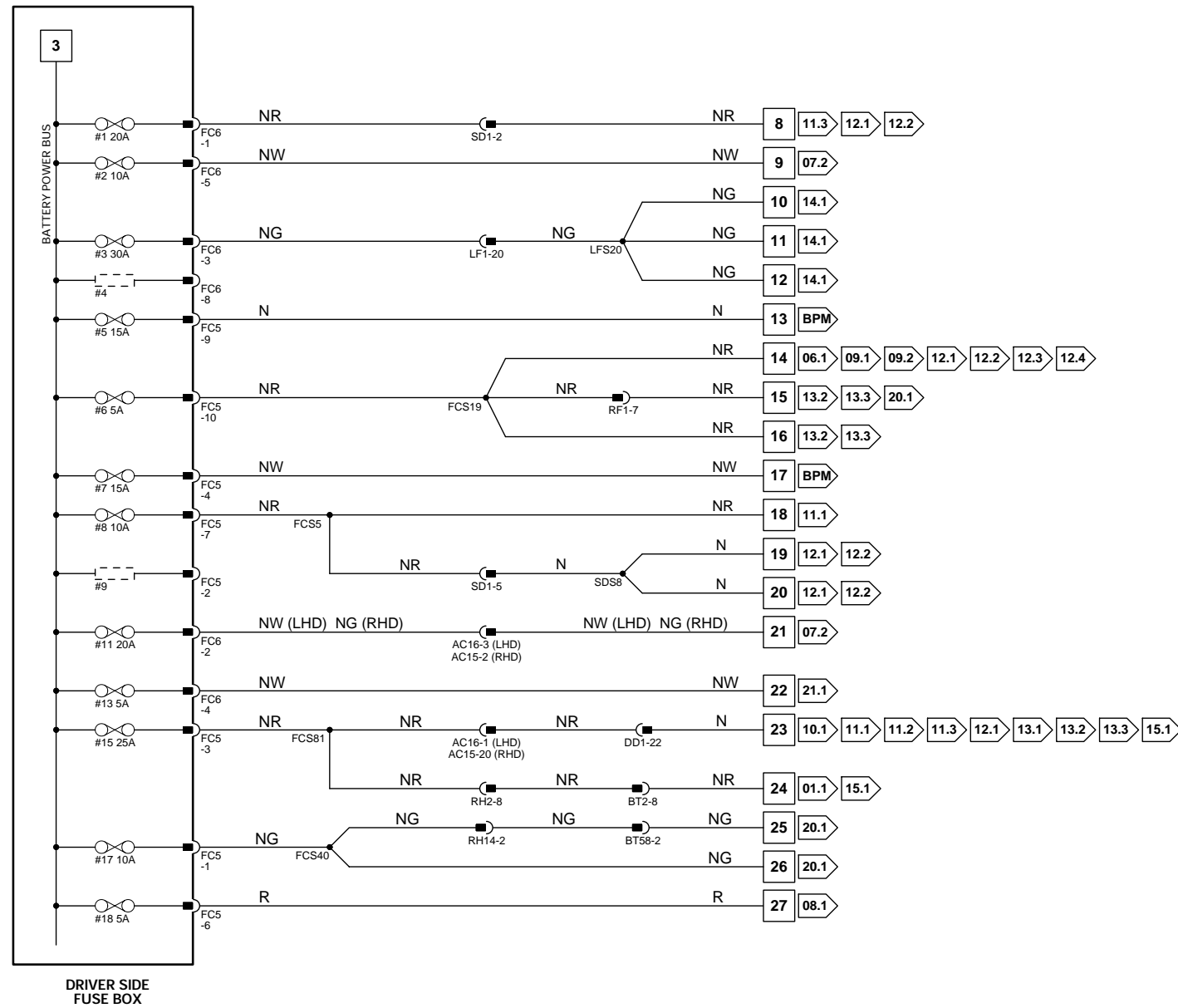

**BPM** NOTE: Body Processor Module appears in numerous Figures.

**Fig. 01.3**

**COMPONENTS**

<b>Component</b>	<b>Connector / Type / Color</b>	<b>Location / Access</b>
FUSE BOX – ENGINE COMPARTMENT	LF5 / 10-WAY U.T.A. FUSEBOX / NATURAL LF6 / 10-WAY U.T.A. FUSEBOX / BLACK LF7 / 10-WAY U.T.A. FUSEBOX / GREEN LF8 / 10-WAY U.T.A. FUSEBOX / BLUE LF70 / EYELET	ENGINE COMPARTMENT / LEFT FRONT
FUSE BOX – ENGINE MANAGEMENT	EM19 / 10-WAY U.T.A. FUSEBOX / NATURAL EM20 / 10-WAY U.T.A. FUSEBOX / BLACK EM70 / EYELET	ENGINE COMPARTMENT / CONTROL MODULE ENCLOSURE
FUSE BOX – TRUNK	BT10 / 10-WAY U.T.A. FUSEBOX / NATURAL BT11 / 10-WAY U.T.A. FUSEBOX / BLACK BT12 / 10-WAY U.T.A. FUSEBOX / GREEN BT13 / 10-WAY U.T.A. FUSEBOX / BLUE BT64 / EYELET	TRUNK / ELECTRICAL CARRIER

**HARNESS-TO-HARNESS CONNECTORS**

<b>Connector</b>	<b>Type / Color</b>	<b>Location / Access</b>
BT1	20-WAY MULTILOCK 070 / WHITE	TRUNK / ABOVE RIGHT HAND REAR WHEEL ARCH
IC4	4-WAY MULTILOCK 070 / WHITE	TRUNK / LEFT OF ANTENNA ASSEMBLY
RH12	18-WAY MULTILOCK 070 / YELLOW	REAR OF CENTER CONSOLE ASSEMBLY

Refer to the front of this book for detailed information and illustrations regarding the location and identification of harnesses, relays, grounds, control modules and control module pins.

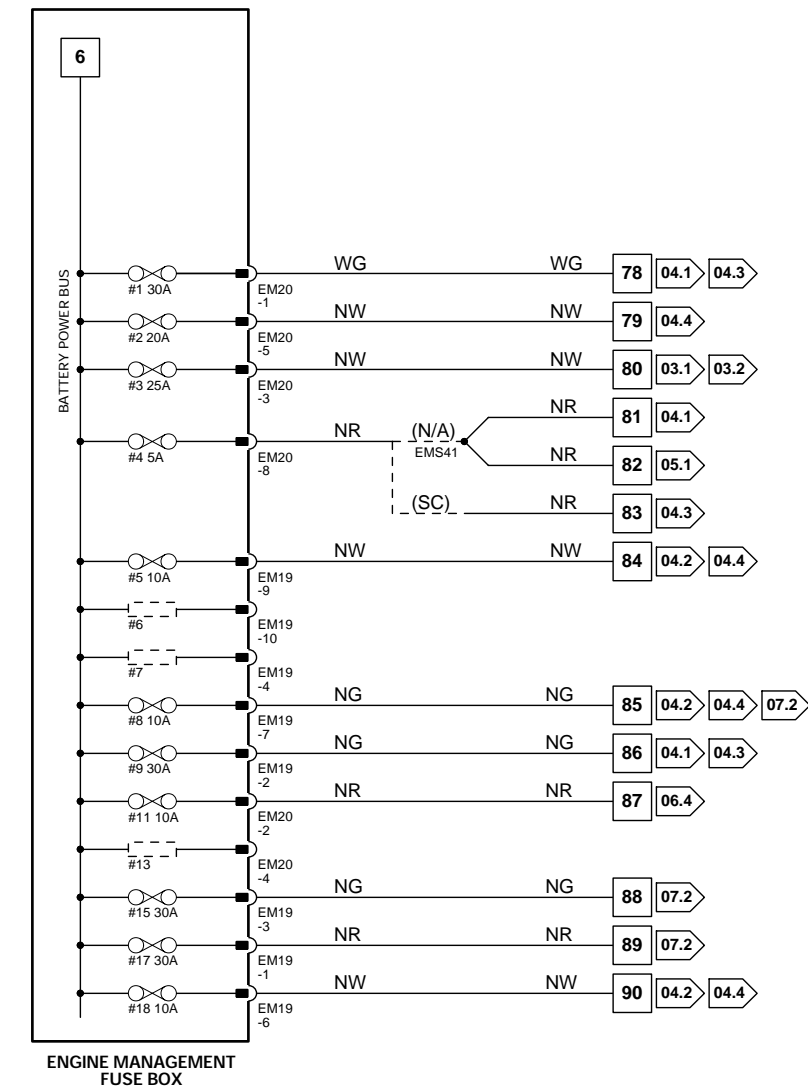
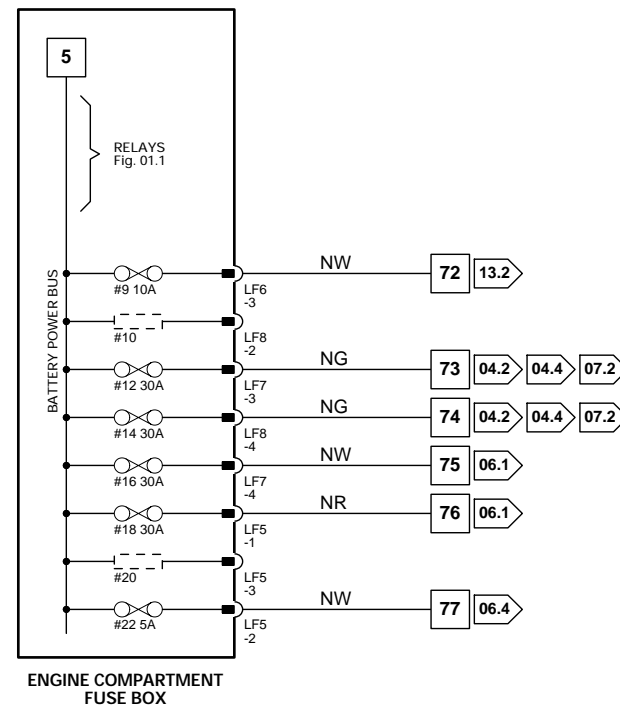
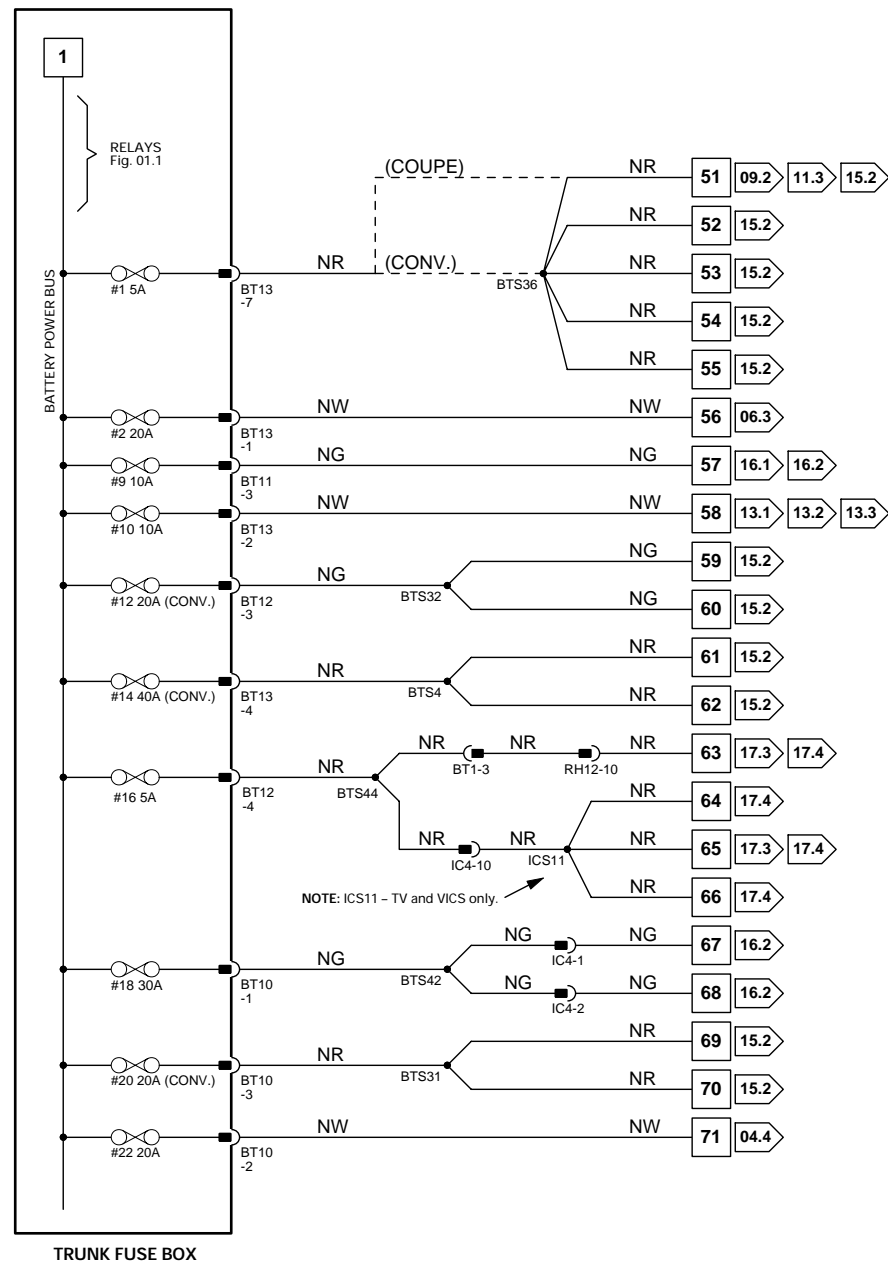

**Fig. 01.4**

**COMPONENTS**

Component	Connector / Type / Color	Location / Access
FUSE BOX – DRIVER SIDE	FC5 / 10-WAY U.T.A. FUSEBOX / NATURAL FC6 / 10-WAY U.T.A. FUSEBOX / BLACK FC90 / EYELET FC92 / EYELET FC94 / EYELET	FASCIA / DRIVER SIDE
FUSE BOX – ENGINE COMPARTMENT	LF5 / 10-WAY U.T.A. FUSEBOX / NATURAL LF6 / 10-WAY U.T.A. FUSEBOX / BLACK LF7 / 10-WAY U.T.A. FUSEBOX / GREEN LF8 / 10-WAY U.T.A. FUSEBOX / BLUE LF70 / EYELET	ENGINE COMPARTMENT / LEFT FRONT
FUSE BOX – PASSENGER SIDE	FC20 / 10-WAY U.T.A. FUSEBOX / NATURAL FC21 / 10-WAY U.T.A. FUSEBOX / BLACK FC90 / EYELET FC93 / EYELET	FASCIA / PASSENGER SIDE
FUSE BOX – TRUNK	BT10 / 10-WAY U.T.A. FUSEBOX / NATURAL BT11 / 10-WAY U.T.A. FUSEBOX / BLACK BT12 / 10-WAY U.T.A. FUSEBOX / GREEN BT13 / 10-WAY U.T.A. FUSEBOX / BLUE BT64 / EYELET	TRUNK / ELECTRICAL CARRIER

**HARNESSTO-HARNESSTO CONNECTORS**

Connector	Type / Color	Location / Access
AC15	20-WAY MULTILOCK 070 / GREY	FASCIA BOTTOM CONNECTOR MOUNTING BRACKET / RIGHT HAND SIDE
BT1	20-WAY MULTILOCK 070 / WHITE	TRUNK / ABOVE RIGHT HAND REAR WHEEL ARCH
EM2	18-WAY MULTILOCK 070 / YELLOW	ENGINE COMPARTMENT / ADJACENT TO RIGHT HAND ENCLOSURE
IC2	14-WAY MULTILOCK 070 / WHITE	BELOW CENTER CONSOLE GLOVE BOX
IC3	14-WAY MULTILOCK 070 / GREY	BELOW CENTER CONSOLE GLOVE BOX
LF3	13-WAY ECONOSEAL III LC / WHITE	LHD: ENGINE COMPARTMENT / ADJACENT TO BRAKE SERVO RHD: ENGINE COMPARTMENT / CONTROL MODULE ENCLOSURE
LF40	13-WAY ECONOSEAL III LC / BLACK	LHD: ENGINE COMPARTMENT / FORWARD OF BRAKE FLUID RESERVOIR RHD: ENGINE COMPARTMENT / BELOW CONTROL MODULE ENCLOSURE
LF60	20-WAY MULTILOCK 070 / WHITE	LEFT HAND 'A' POST CONNECTOR MOUNTING BRACKET / 'A' POST TRIM
PI2	13-WAY ECONOSEAL III LC / BLACK	ENGINE COMPARTMENT / BRACKET ON TOP OF TRANSMISSION
RF1	24-WAY CONNECTOR / BLACK	RIGHT HAND 'A' POST CONNECTOR MOUNTING BRACKET / 'A' POST TRIM
RH2	20-WAY MULTILOCK 070 / WHITE	REAR OF CENTER CONSOLE ASSEMBLY
RH9	20-WAY MULTILOCK 070 / YELLOW	BELOW CENTER CONSOLE
SD1	14-WAY MULTILOCK 070 / YELLOW	BELOW DRIVER SEAT
SP1	14-WAY MULTILOCK 070 / YELLOW	BELOW PASSENGER SEAT

Refer to the front of this book for detailed information and illustrations regarding the location and identification of harnesses, relays, grounds, control modules and control module pins.



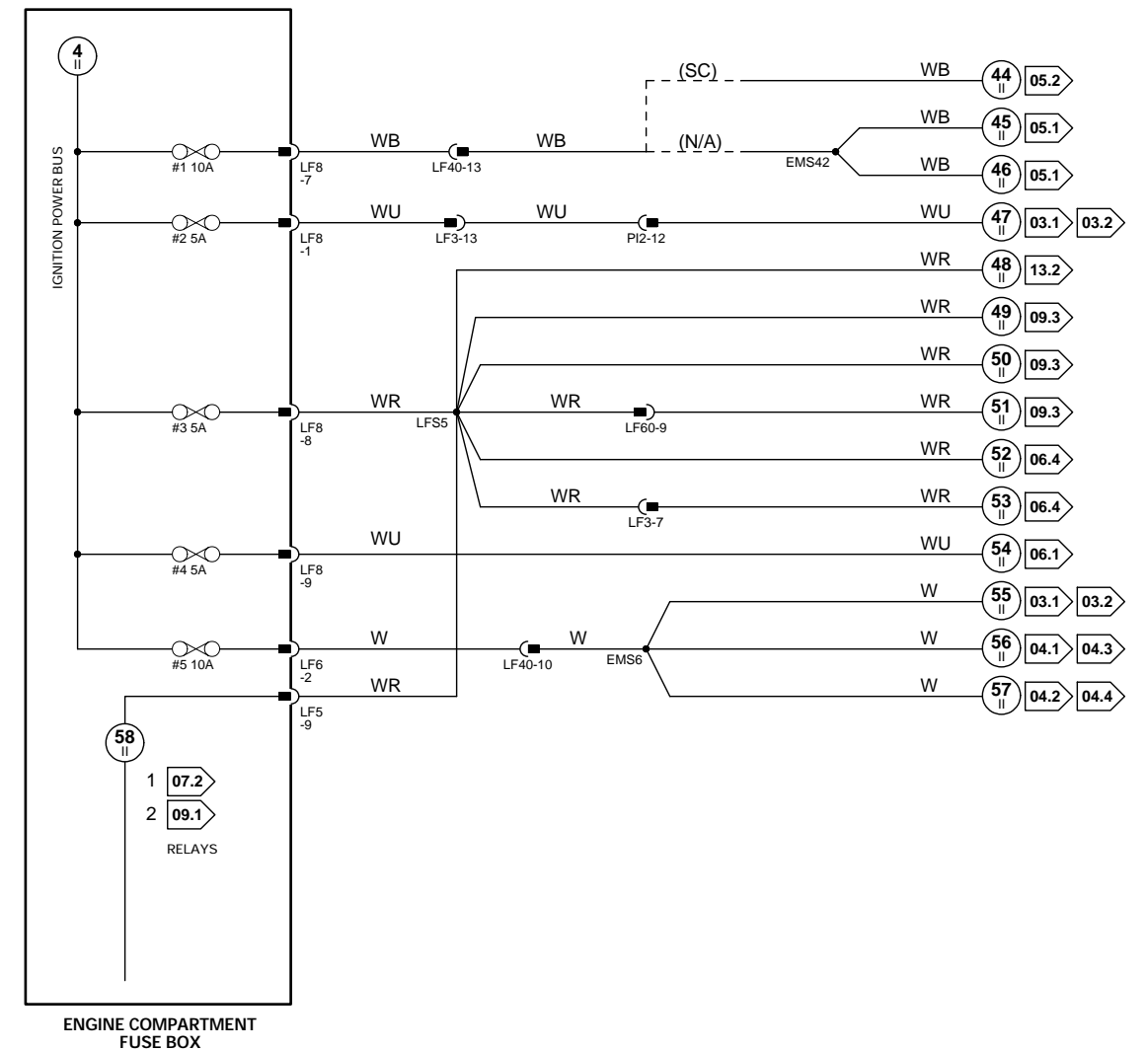
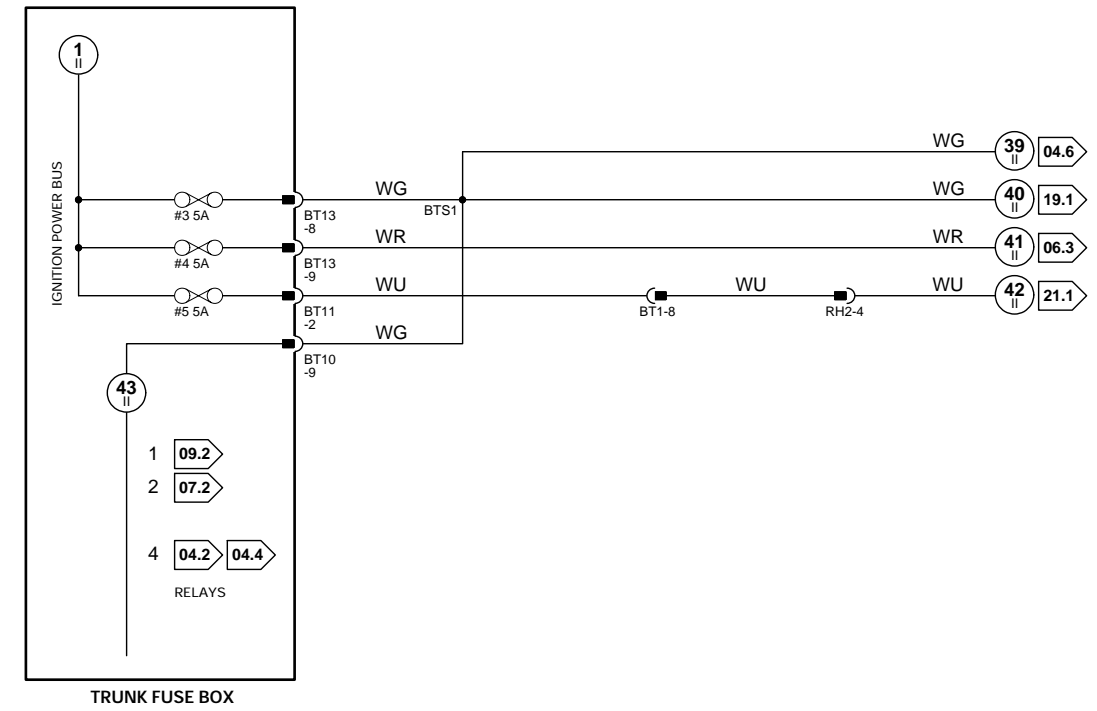
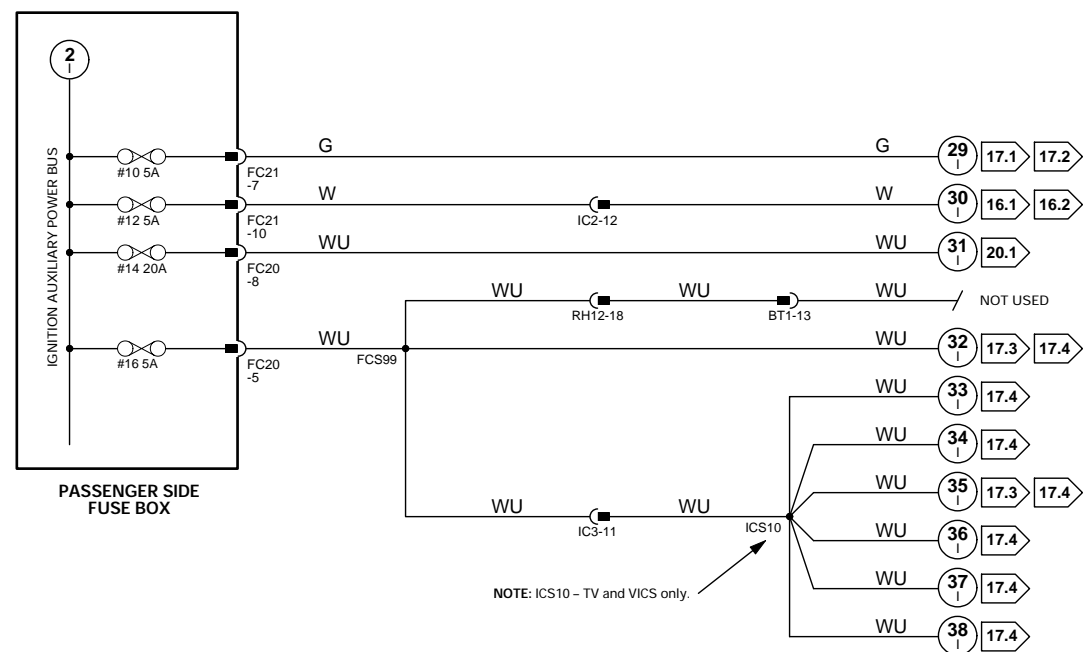
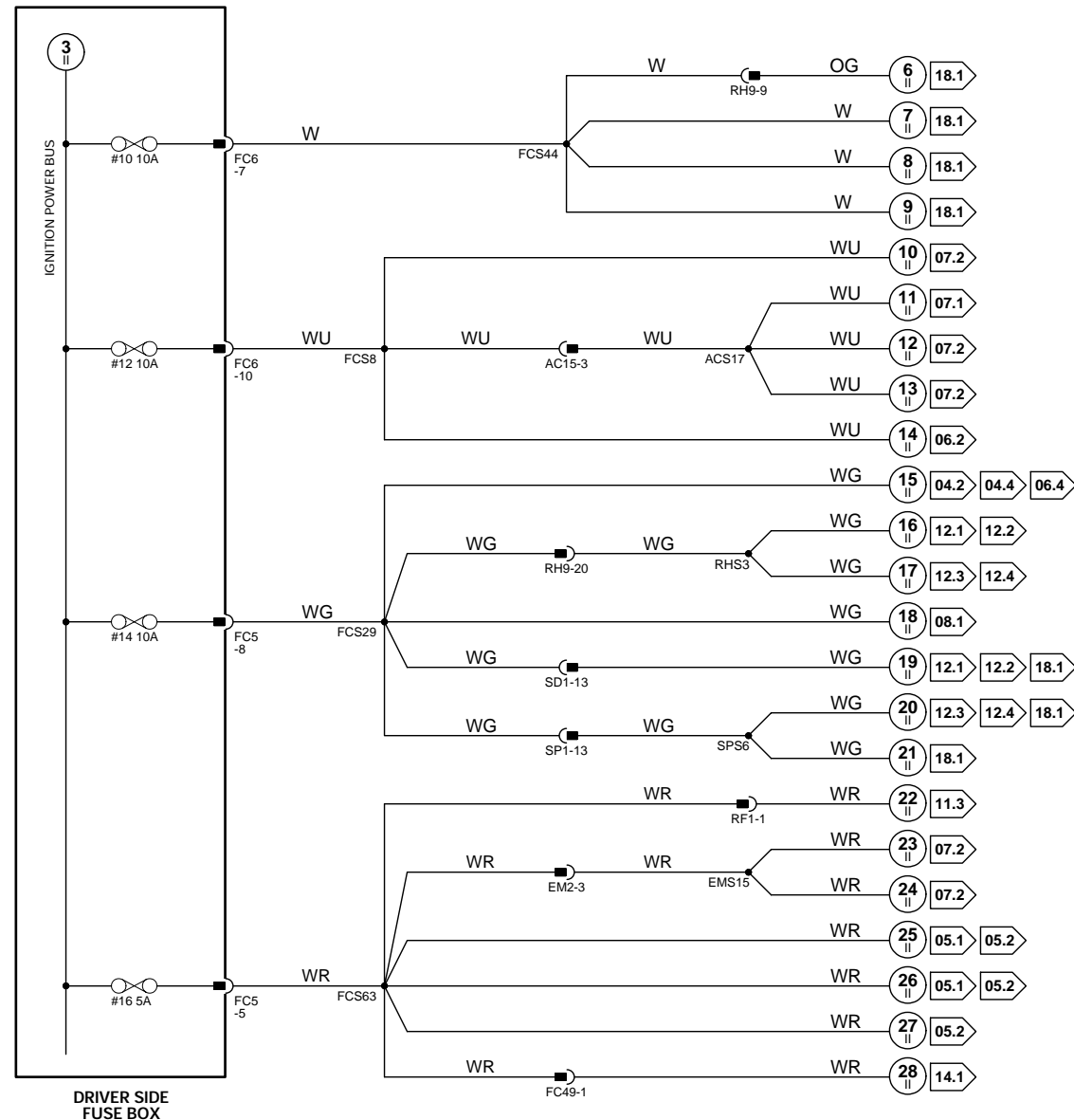

**Fig. 01.5****COMPONENTS****Component**

FUSE BOX – ENGINE MANAGEMENT

**Connector / Type / Color**EM19 / 10-WAY U.T.A. FUSEBOX / NATURAL  
EM20 / 10-WAY U.T.A. FUSEBOX / BLACK  
EM70 / EYELET**Location / Access**

ENGINE COMPARTMENT / CONTROL MODULE ENCLOSURE

**HARNESS-TO-HARNESS CONNECTORS****Connector**BT1  
EM3  
LF3  
  
LF40  
  
PI1  
RH2**Type / Color**20-WAY MULTILOCK 070 / WHITE  
14-WAY MULTILOCK 070 / GREY  
13-WAY ECONOSEAL III LC / WHITE  
  
13-WAY ECONOSEAL III LC / BLACK  
  
57-WAY SUMITOMO TS090 / BLACK  
20-WAY MULTILOCK 070 / WHITE**Location / Access**TRUNK / ABOVE RIGHT HAND REAR WHEEL ARCH  
ENGINE COMPARTMENT / ADJACENT TO RIGHT HAND ENCLOSURE  
LHD: ENGINE COMPARTMENT / ADJACENT TO BRAKE SERVO  
RHD: ENGINE COMPARTMENT / CONTROL MODULE ENCLOSURE  
LHD: ENGINE COMPARTMENT / FORWARD OF BRAKE FLUID RESERVOIR  
RHD: ENGINE COMPARTMENT / BELOW CONTROL MODULE ENCLOSURE  
ENGINE COMPARTMENT / BRACKET ON TOP OF TRANSMISSION  
REAR OF CENTER CONSOLE ASSEMBLY

Refer to the front of this book for detailed information and illustrations regarding the location and identification of harnesses, relays, grounds, control modules and control module pins.

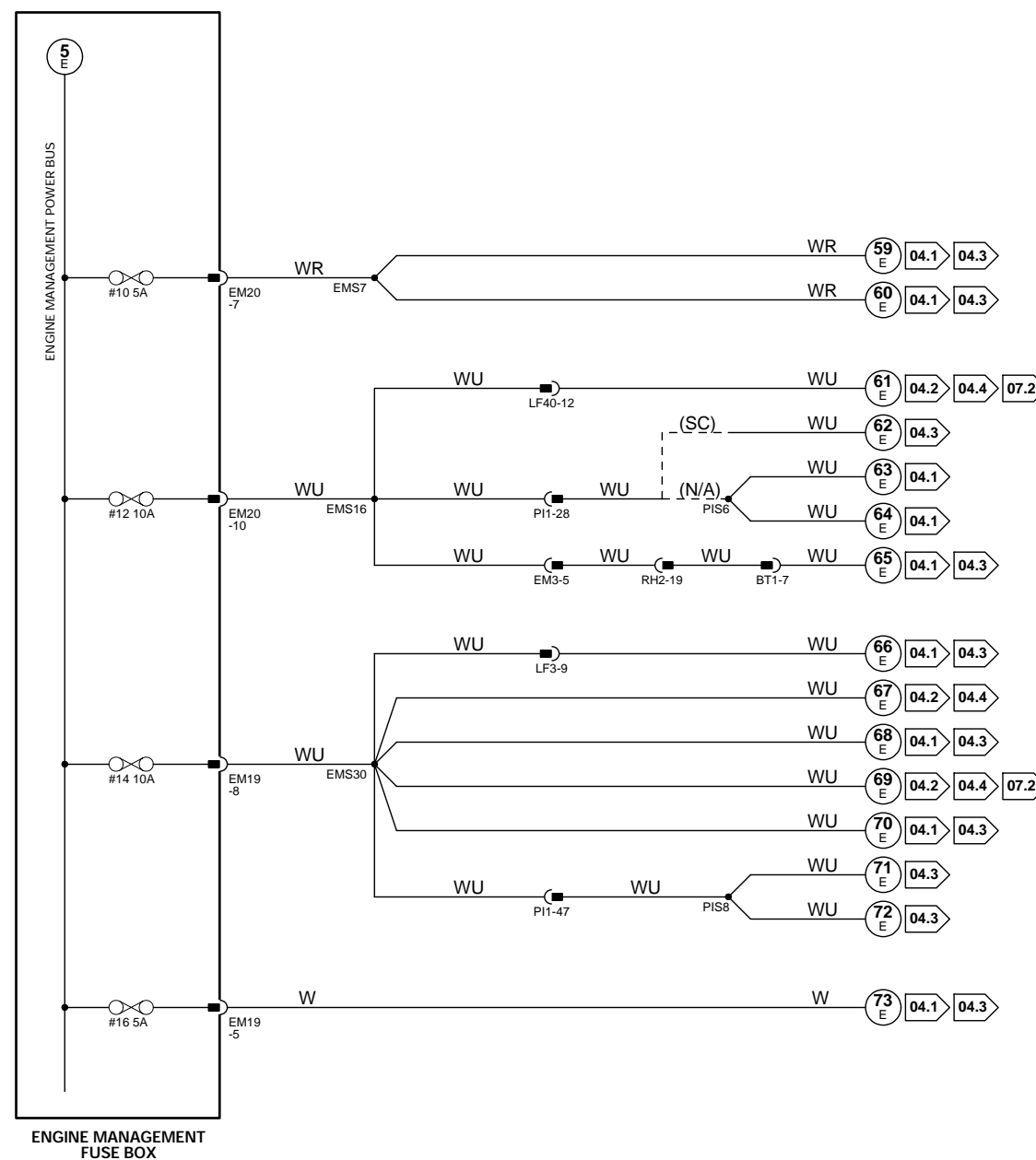

**Fig. 02.1**

**COMPONENTS**

**Component**

IGNITION SWITCH (KEY-IN SWITCH)  
INERTIA SWITCH

**Connector / Type / Color**

FC4 / 8-WAY MULTILOCK 070 / WHITE  
FC46 / 3-WAY ECONOSEAL III LC / BLACK

**Location / Access**

STEERING COLUMN  
ADJACENT TO LEFT HAND FASCIA FUSE BOX

**HARNESS-TO-HARNESS CONNECTORS**

**Connector**

AC13  
BT1  
LF60  
RH2

**Type / Color**

20-WAY MULTILOCK 070 / YELLOW  
20-WAY MULTILOCK 070 / WHITE  
20-WAY MULTILOCK 070 / WHITE  
20-WAY MULTILOCK 070 / WHITE

**Location / Access**

FASCIA BOTTOM CONNECTOR MOUNTING BRACKET / RIGHT HAND SIDE  
TRUNK / ABOVE RIGHT HAND REAR WHEEL ARCH  
LEFT HAND 'A' POST CONNECTOR MOUNTING BRACKET / 'A' POST TRIM  
REAR OF CENTER CONSOLE ASSEMBLY

**GROUNDS**

**Ground**

FC3BL

**Location / Type**

EYELET (PAIR) – LEFT HAND LEG / TRANSMISSION TUNNEL, LEFT HAND SIDE

Refer to the front of this book for detailed information and illustrations regarding the location and identification of harnesses, relays, grounds, control modules and control module pins.

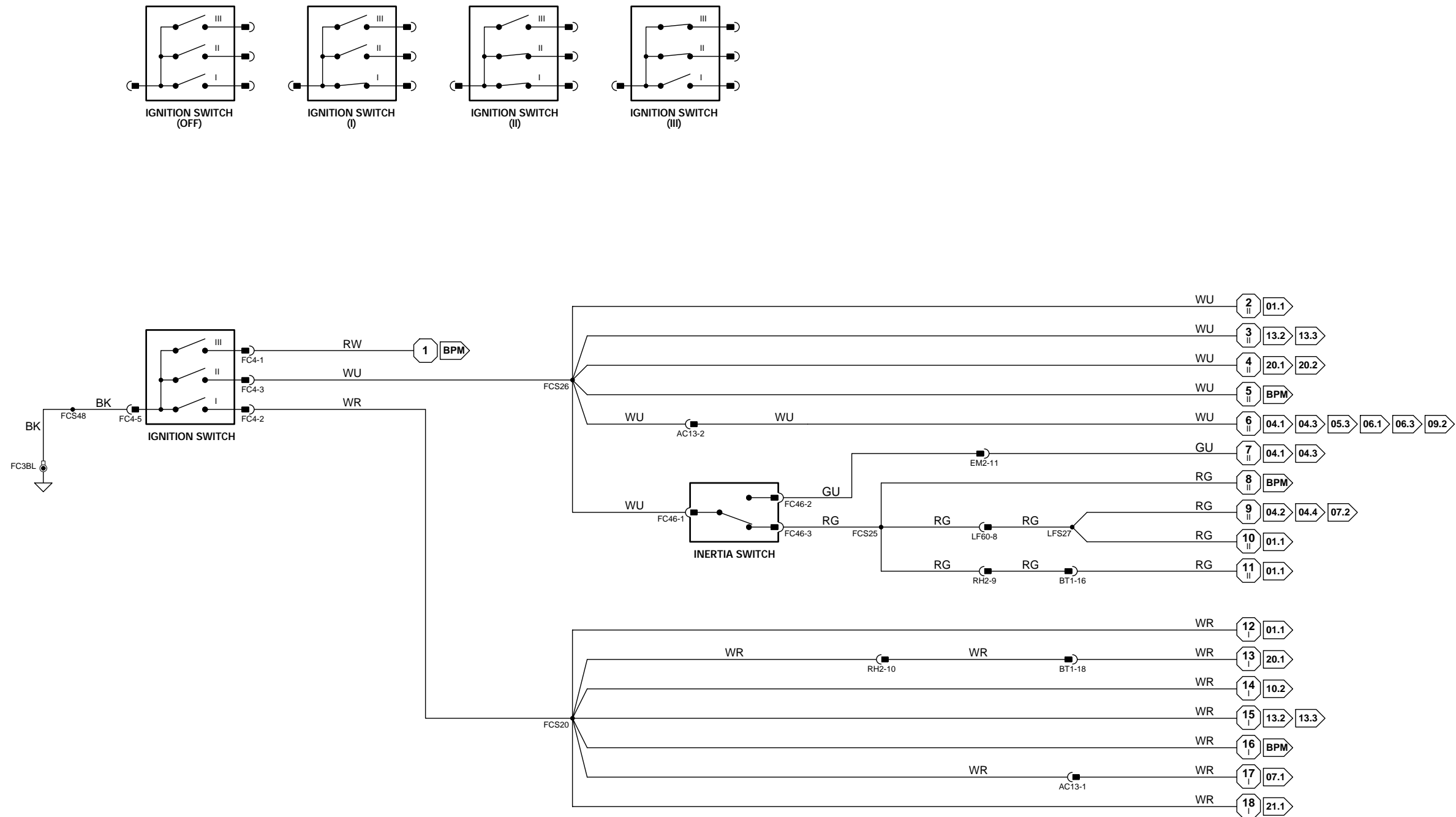

**BPM** NOTE: Body Processor Module appears in numerous Figures.

**CONTROL MODULE PIN OUT INFORMATION**

**Fig. 03.1**

**BODY PROCESSOR MODULE**

Pin	Description	Active	Inactive
I FC14-7	NEUTRAL SWITCH STATUS	GROUND (N)	B+ (P, R, D, 4, 3, 2)
D FC14-39	SECURITY ACKNOWLEDGE	ENCODED COMMUNICATIONS	
I FC14-41	STARTER ENGAGE REQUEST	GROUND (CRANKING)	B+
O FC14-73	STARTER RELAY ACTIVATE	GROUND (CRANKING)	B+
I FC14-80	BATTERY SUPPLY VOLTAGE	B+	B+
D FC14-92	ENCODED COMMUNICATIONS		

**ENGINE CONTROL MODULE**

Pin	Description	Active	Inactive
I EM81-12	PARK / NEUTRAL CONFIRMATION	B+ (P, N)	GROUND (R,D,4,3,2)
I EM82-2	ENGINE CRANK	GROUND (CRANKING)	
D EM82-15	OK TO START	ENCODED COMMUNICATIONS	
D EM82-16	SECURITY ACKNOWLEDGE	ENCODED COMMUNICATIONS	

**KEY TRANSPONDER MODULE**

Pin	Description	Active	Inactive
D FC22-9	GLASS BREAKAGE / OK TO START (ENCODED COMMUNICATION)		
D FC22-16	OK TO START (ENCODED COMMUNICATION)		
D FC22-17	SECURITY ACKNOWLEDGE (ENCODED COMMUNICATION)		

**COMPONENTS**

Component	Connector / Type / Color	Location / Access
BATTERY	BT66 / EYELET BT67 / EYELET	TRUNK, RIGHT HAND SIDE
BODY PROCESSOR MODULE ENGINE CONTROL MODULE	FC14 / 104-WAY AMP EEEEC / GREY EM80 / 31-WAY AMP 403 / NATURAL EM81 / 24-WAY AMP 403 / NATURAL EM82 / 17-WAY AMP 403 / NATURAL EM83 / 28-WAY AMP 403 / NATURAL EM84 / 22-WAY AMP 403 / NATURAL EM85 / 12-WAY MULTILOCK 070 / WHITE	PASSENGER SIDE FASCIA / AIRBAG BRACKET ENGINE COMPARTMENT / CONTROL MODULE ENCLOSURE
GENERATOR	AN1 / EYELET AN2 / EYELET ST11 / EYELET	ENGINE COMPARTMENT / RIGHT FRONT
HIGH POWER PROTECTION MODULE	BT60 / EYELET BT61 / EYELET BT62 / EYELET BT63 / EYELET	TRUNK / ADJACENT TO BATTERY
IGNITION SWITCH (KEY-IN SWITCH) KEY TRANSPONDER MODULE NEUTRAL SWITCH REGULATOR (GENERATOR) STARTER MOTOR	FC4 / 8-WAY MULTILOCK 070 / WHITE FC22 / 20-WAY MULTILOCK 040 / GREEN FC89 / 3-WAY MULTILOCK 070 / GREY PI50 / 3-WAY SUMITOMO 0902 / BLACK ST3 / EYELET ST10 / EYELET	STEERING COLUMN ADJACENT TO DRIVER SIDE FUSE BOX GEAR SELECTOR ASSEMBLY ENGINE COMPARTMENT / GENERATOR ENGINE BLOCK
SUPPRESSION MODULE	AN3 / 2-WAY ECONOSEAL III LC/ RED	REARWARD OF RIGHT FRONT HEADLAMP

**RELAYS**

Relay	Color / Stripe	Connector / Color	Location / Access
STARTER RELAY	BROWN	EM50 / BROWN	RH ENCLOSURE RELAYS

**HARNESS-TO-HARNESS CONNECTORS**

Connector	Type / Color	Location / Access
BT80	EYELET	ENGINE COMPARTMENT / FALSE BULKHEAD, RIGHT HAND SIDE
EM1	20-WAY MULTILOCK 070 / WHITE	ENGINE COMPARTMENT / ADJACENT TO RIGHT HAND ENCLOSURE
EM2	18-WAY MULTILOCK 070 / YELLOW	ENGINE COMPARTMENT / ADJACENT TO RIGHT HAND ENCLOSURE
EM3	14-WAY MULTILOCK 070 / GREY	ENGINE COMPARTMENT / ADJACENT TO RIGHT HAND ENCLOSURE
EM60	2-WAY ECONOSEAL III HC / BLACK	ENGINE COMPARTMENT / BEHIND LEFT INNER FENDER HEAT SHIELD
PI1	57-WAY SUMITOMO TS090 / BLACK	ENGINE COMPARTMENT / BRACKET ON TOP OF TRANSMISSION
ST1	EYELET	ENGINE COMPARTMENT / FALSE BULKHEAD, RIGHT HAND SIDE

**GROUND**

Ground	Location / Type
BT68	BATTERY GROUND STUD
FC3BR	EYELET (PAIR) – RIGHT HAND LEG / TRANSMISSION TUNNEL, LEFT HAND SIDE

FOR CONTROL MODULE PIN OUT INFORMATION, UNFOLD PAGE TO LEFT.

The following abbreviations are used to represent values for Control Module Pin-Out data

I	Input	SG	Sensor Ground	S	SCP Network	V	Voltage (DC)
O	Output	A	ACP Network	D	Serial and Encoded Data	Hz	Frequency
SS	Sensor Supply V	C	CAN (Network)	B+	Battery Voltage	kHz	Frequency x 1000

CAUTION: The information on this data page is furnished to aid the user in understanding circuit operation. THIS INFORMATION SHOULD BE USED FOR REFERENCE ONLY.

NOTE: The values listed are approximately those that can be expected at the control module connector pins with all circuit connections made and all components connected and fitted. "Active" means a load is applied or a switch is ON; "Inactive" means a load is not applied or a switch is OFF.

Refer to the front of this book for detailed information and illustrations regarding the location and identification of harnesses, relays, grounds, control modules and control module pins.

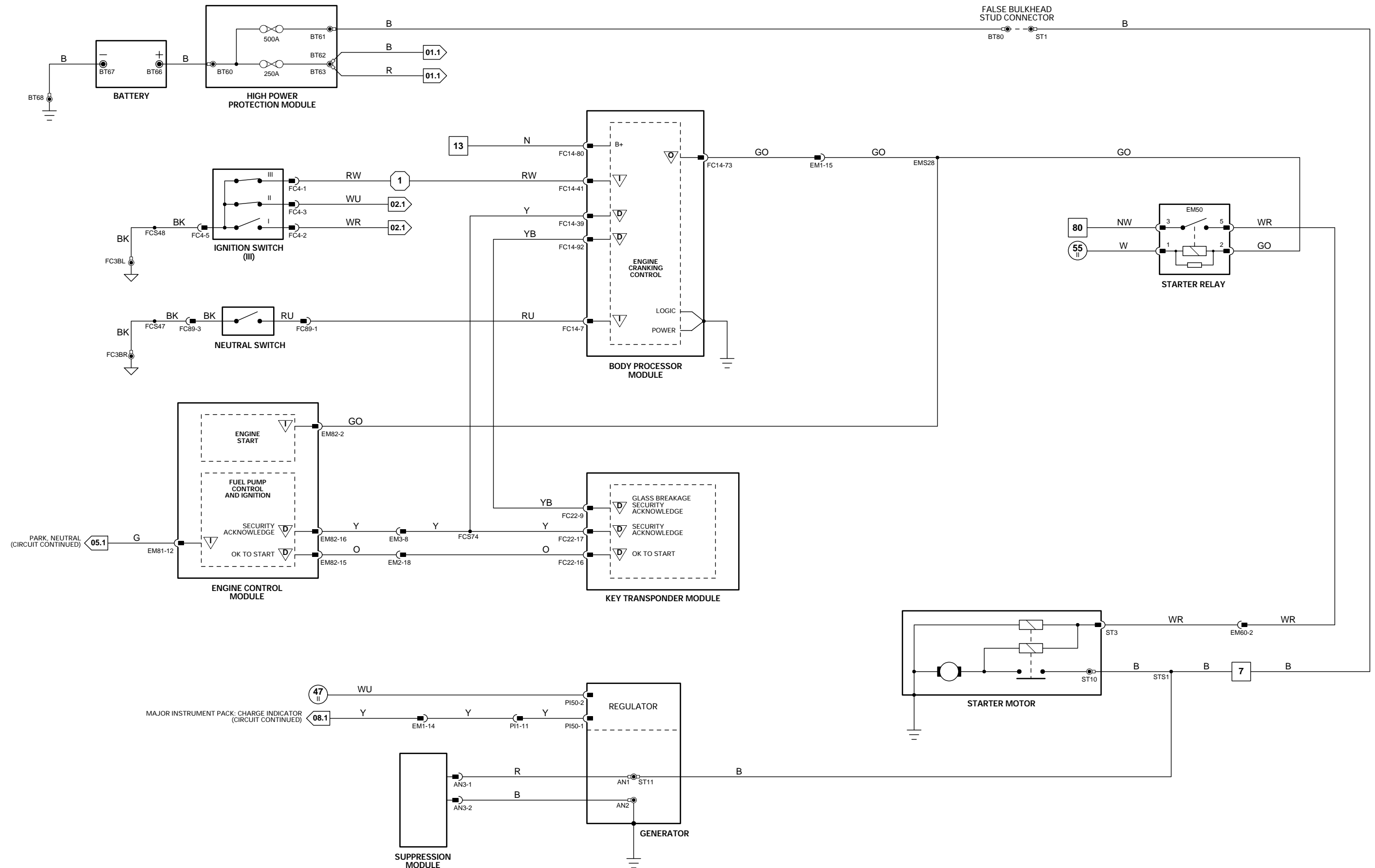

1 → 7 Fig. 01.1   
 1 → 5 Fig. 01.1   
 8 → 50 Fig. 01.2   
 51 → 90 Fig. 01.3   
 6 → 58 Fig. 01.4   
 59 → 73 Fig. 01.5   
 1 → 18 Fig. 02.1

▽ Input    ⚡ Sensor Supply V    ⚠ ACP    ⚠ SCP  
 ▽ Output    ⚠ Sensor Ground    ⚠ CAN    ⚠ Serial and Encoded Data

**VARIANT:** AJ27 N/A Vehicles  
**VIN RANGE:** A11051 →  
**DATE OF ISSUE:** September 2000

**CONTROL MODULE PIN OUT INFORMATION**

**Fig. 03.2**

**BODY PROCESSOR MODULE**

Pin	Description	Active	Inactive
I FC14-7	NEUTRAL SWITCH STATUS	GROUND (N)	B+ (P, R, D, 4, 3, 2)
D FC14-39	SECURITY ACKNOWLEDGE	ENCODED COMMUNICATIONS	
I FC14-41	STARTER ENGAGE REQUEST	GROUND (CRANKING)	B+
O FC14-73	STARTER RELAY ACTIVATE	GROUND (CRANKING)	B+
I FC14-80	BATTERY SUPPLY VOLTAGE	B+	B+
D FC14-92	ENCODED COMMUNICATIONS		

**ENGINE CONTROL MODULE**

Pin	Description	Active	Inactive
I EM81-12	PARK / NEUTRAL CONFIRMATION	B+ (P, N)	GROUND (R,D,4,3,2)
I EM82-2	ENGINE CRANK	GROUND (CRANKING)	
D EM82-15	OK TO START	ENCODED COMMUNICATIONS	
D EM82-16	SECURITY ACKNOWLEDGE	ENCODED COMMUNICATIONS	

**KEY TRANSPONDER MODULE**

Pin	Description	Active	Inactive
D FC22-9	GLASS BREAKAGE / OK TO START (ENCODED COMMUNICATION)		
D FC22-16	OK TO START (ENCODED COMMUNICATION)		
D FC22-17	SECURITY ACKNOWLEDGE (ENCODED COMMUNICATION)		

**COMPONENTS**

Component	Connector / Type / Color	Location / Access
BATTERY	BT66 / EYELET BT67 / EYELET	TRUNK, RIGHT HAND SIDE
BODY PROCESSOR MODULE DUAL LINEAR SWITCH ENGINE CONTROL MODULE	FC14 / 104-WAY AMP EEEEC / GREY FC100 / 12-WAY / MULTILOCK 070 / GREY EM80 / 31-WAY AMP 403 / NATURAL EM81 / 24-WAY AMP 403 / NATURAL EM82 / 17-WAY AMP 403 / NATURAL EM83 / 28-WAY AMP 403 / NATURAL EM84 / 22-WAY AMP 403 / NATURAL EM85 / 12-WAY MULTILOCK 070 / WHITE	PASSENGER SIDE FASCIA / AIRBAG BRACKET LEFT HAND SIDE OF GEAR SELECTOR / CENTER CONSOLE ENGINE COMPARTMENT / CONTROL MODULE ENCLOSURE
GENERATOR	AN1 / EYELET AN2 / EYELET ST11 / EYELET	ENGINE COMPARTMENT / RIGHT FRONT
HIGH POWER PROTECTION MODULE	BT60 / EYELET BT61 / EYELET BT62 / EYELET BT63 / EYELET	TRUNK / ADJACENT TO BATTERY
IGNITION SWITCH (KEY-IN SWITCH) KEY TRANSPONDER MODULE REGULATOR (GENERATOR) STARTER MOTOR	FC4 / 8-WAY MULTILOCK 070 / WHITE FC22 / 20-WAY MULTILOCK 040 / GREEN PI50 / 3-WAY SUMITOMO 0902 / BLACK ST3 / EYELET ST10 / EYELET	STEERING COLUMN ADJACENT TO DRIVER SIDE FUSE BOX ENGINE COMPARTMENT / GENERATOR ENGINE BLOCK
SUPPRESSION MODULE	AN3 / 2-WAY ECONOSEAL III LC/ RED	REARWARD OF RIGHT FRONT HEADLAMP

**RELAYS**

Relay	Color / Stripe	Connector / Color	Location / Access
STARTER RELAY	BROWN	EM50 / BROWN	RH ENCLOSURE RELAYS

**HARNESS-TO-HARNESS CONNECTORS**

Connector	Type / Color	Location / Access
BT80	EYELET	ENGINE COMPARTMENT / FALSE BULKHEAD, RIGHT HAND SIDE
EM1	20-WAY MULTILOCK 070 / WHITE	ENGINE COMPARTMENT / ADJACENT TO RIGHT HAND ENCLOSURE
EM2	18-WAY MULTILOCK 070 / YELLOW	ENGINE COMPARTMENT / ADJACENT TO RIGHT HAND ENCLOSURE
EM3	14-WAY MULTILOCK 070 / GREY	ENGINE COMPARTMENT / ADJACENT TO RIGHT HAND ENCLOSURE
EM60	2-WAY ECONOSEAL III HC / BLACK	ENGINE COMPARTMENT / BEHIND LEFT INNER FENDER HEAT SHIELD
PI1	57-WAY SUMITOMO TS090 / BLACK	ENGINE COMPARTMENT / BRACKET ON TOP OF TRANSMISSION
ST1	EYELET	ENGINE COMPARTMENT / FALSE BULKHEAD, RIGHT HAND SIDE

**GROUND**

Ground	Location / Type
BT68	BATTERY GROUND STUD
EM1AR	EYELET (PAIR) – RIGHT HAND LEG / ENGINE COMPARTMENT, RIGHT HAND ENCLOSURE
EM2AL	EYELET (PAIR) – LEFT HAND LEG / ENGINE COMPARTMENT, LEFT HAND ENCLOSURE

FOR CONTROL MODULE PIN OUT INFORMATION, UNFOLD PAGE TO LEFT.

The following abbreviations are used to represent values for Control Module Pin-Out data

I	Input	SG	Sensor Ground	S	SCP Network	V	Voltage (DC)
O	Output	A	ACP Network	D	Serial and Encoded Data	Hz	Frequency
SS	Sensor Supply V	C	CAN (Network)	B+	Battery Voltage	kHz	Frequency x 1000

CAUTION: The information on this data page is furnished to aid the user in understanding circuit operation. THIS INFORMATION SHOULD BE USED FOR REFERENCE ONLY.

NOTE: The values listed are approximately those that can be expected at the control module connector pins with all circuit connections made and all components connected and fitted. "Active" means a load is applied or a switch is ON; "Inactive" means a load is not applied or a switch is OFF.

Refer to the front of this book for detailed information and illustrations regarding the location and identification of harnesses, relays, grounds, control modules and control module pins.



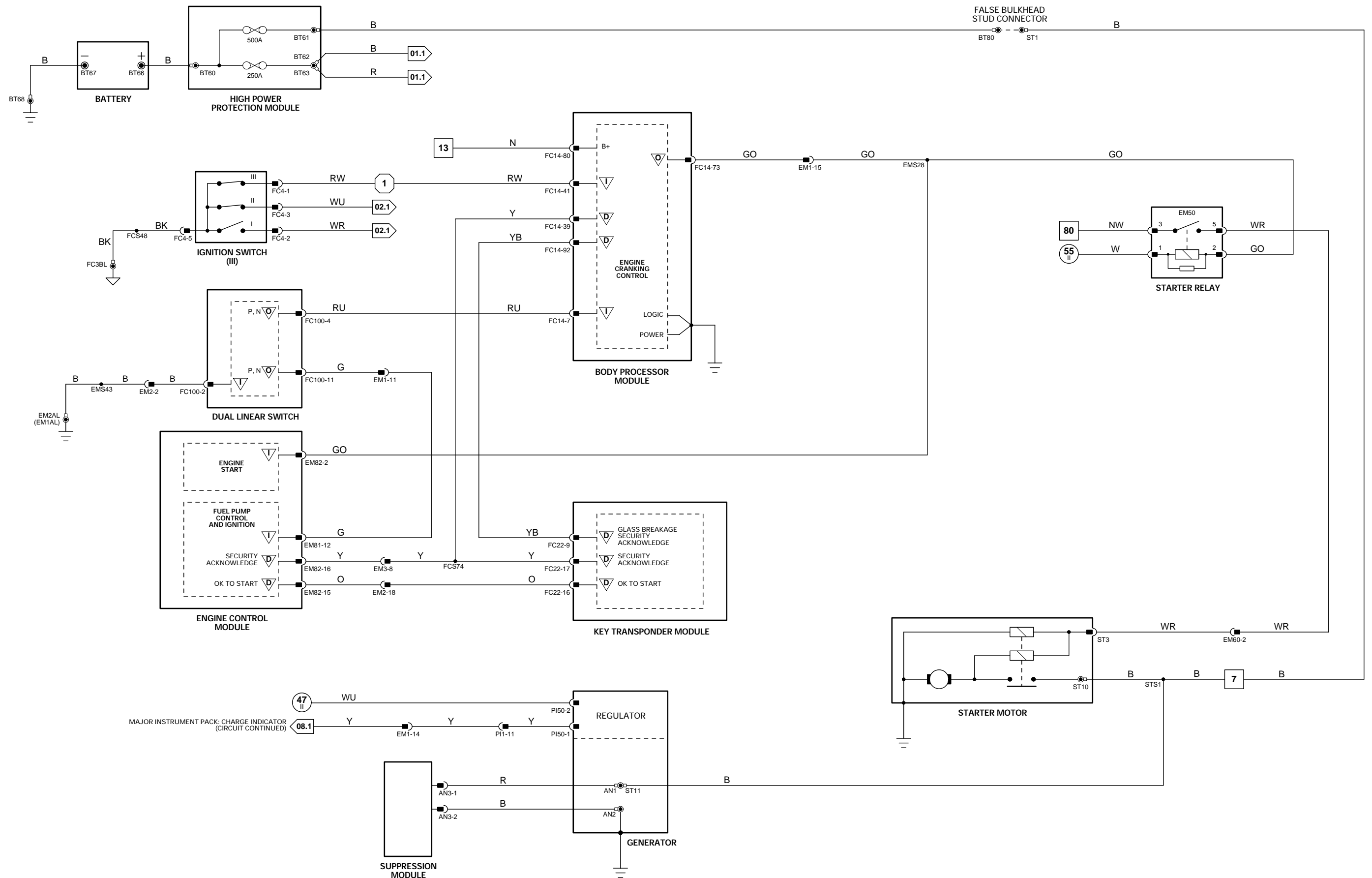

1 → 7 Fig. 01.1   
 1 → 5 Fig. 01.1   
 8 → 50 Fig. 01.2   
 51 → 90 Fig. 01.3   
 6 → 58 Fig. 01.4   
 59 → 73 Fig. 01.5   
 1 → 18 Fig. 02.1

▽ Input    + Sensor Supply V    ▽ ACP    ▽ SCP  
 ▽ Output    ▽ Sensor Ground    ▽ CAN    ▽ Serial and Encoded Data

**VARIANT:** AJ27 SC Vehicles  
**VIN RANGE:** A11051 →  
**DATE OF ISSUE:** September 2000

## CONTROL MODULE PIN OUT INFORMATION

### ENGINE CONTROL MODULE

Pin	Description	Active	Inactive
O	EM80-01	EVAP VALVE ACTIVATE	GROUND (VALVE OPEN)
O	EM80-02	CANISTER CLOSE VALVE ACTIVATE	GROUND
I	EM80-03	GROUND (POWER)	GROUND
O	EM80-04	THROTTLE MOTOR POWER SUPPLY	B+
O	EM80-05	THROTTLE MOTOR POWER SUPPLY	B+
O	EM80-06	THROTTLE MOTOR POWER SUPPLY	B+
O	EM80-07	THROTTLE MOTOR POWER SUPPLY	B+
I	EM80-08	THROTTLE MOTOR POWER SUPPLY	B+
I	EM80-09	THROTTLE MOTOR POWER SUPPLY	B+
I	EM80-15	EOT SIGNAL	2.5 V @ 34 °C; 0.5 V @ 90 °C; (DECREASING VOLTAGE WITH TEMPERATURE INCREASE)
D	EM80-17	SERIAL COMMUNICATIONS	
D	EM80-18	SERIAL COMMUNICATIONS	
D	EM80-19	ECM PROGRAMMING	
I	EM80-21	GROUND (THROTTLE MOTOR 1)	GROUND
D	EM80-27	ECM PROGRAMMING	
I	EM80-29	GROUND (LOGIC 2)	GROUND
I	EM80-31	GROUND (THROTTLE MOTOR 2)	GROUND
O	EM81-01	VARIABLE VALVE TIMING SOLENOID + 'A' BANK	B+ (12% DUTY CYCLE @ IDLE) ((INCREASING WITH ADVANCE)
SG	EM81-02	VARIABLE VALVE TIMING SOLENOID - 'A' BANK	GROUND
O	EM81-03	EMS CONTROLLED RELAY ACTIVATE	GROUND
O	EM81-06	VARIABLE VALVE TIMING SOLENOID + 'B' BANK	B+ (12% DUTY CYCLE @ IDLE) ((INCREASING WITH ADVANCE)
SG	EM81-07	VARIABLE VALVE TIMING SOLENOID - 'B' BANK	GROUND
I	EM81-08	GROUND (POWER)	GROUND
I	EM81-09	PEDAL POSITION SIGNAL (PPS/1)	0.6 V = FOOT OFF; 3.8 V = PEDAL FULLY DEPRESSED
I	EM81-10	TPS SIGNAL (TPS/1)	0.5 V = IDLE; 4.75 V = WOT
I	EM81-12	PARK / NEUTRAL CONFIRMATION	B+ (P, N)
I	EM81-16	FUEL TANK PRESSURE SENSOR SIGNAL	4.9 V = LOW PRESSURE, 0.2 V = HIGH PRESSURE
I	EM81-17	EMS SWITCHED POWER SUPPLY 1	B+
I	EM81-18	PEDAL POSITION SIGNAL (PPS/2)	0.8 V = FOOT OFF; 2.4 V = PEDAL FULLY DEPRESSED
I	EM81-19	TPS SIGNAL (TPS/2)	0.6 V = IDLE; 4.85 V = WOT
I	EM81-21	GROUND (LOGIC 1)	GROUND
I	EM81-22	PARKING BRAKE SWITCH	GROUND (APPLIED)
SG	EM81-24	PEDAL POSITION / THROTTLE POSITION SENSORS SHIELD	GROUND
SS	EM82-01	SENSOR SUPPLY VOLTAGE 1	5 V
I	EM82-02	ENGINE CRANK	GROUND (CRANKING)
I	EM82-04	HO2S, UPSTREAM 'A' BANK - VARIABLE CURRENT (µA)	3.5 V
I	EM82-05	HO2S, UPSTREAM 'B' BANK - VARIABLE CURRENT (µA)	3.5 V
O	EM82-06	THROTTLE MOTOR POWER RELAY ACTIVATE	GROUND
SG	EM82-07	SENSORS SIGNAL GROUND 1	GROUND
I	EM82-08	BRAKE SWITCH	GROUND
I	EM82-09	IGNITION SWITCHED POWER SUPPLY	B+
SS	EM82-10	HO2S, UPSTREAM 'A' BANK - CONSTANT	3.8 V
SS	EM82-11	HO2S, UPSTREAM 'B' BANK - CONSTANT	3.8 V
I	EM82-12	INERTIA SWITCH ACTIVATED (VEHICLE IMPACT)	GROUND
I	EM82-13	EMS SWITCHED POWER SUPPLY 2	B+
I	EM82-14	ECT SIGNAL	0.41 V @ 90 °C (DECREASING VOLTAGE WITH TEMPERATURE INCREASE)
D	EM82-15	OK TO START	ENCODED COMMUNICATIONS
D	EM82-16	SECURITY ACKNOWLEDGE	ENCODED COMMUNICATIONS
I	EM82-17	IATS SIGNAL	0.98 V @ 10 °C (DECREASING VOLTAGE WITH TEMPERATURE INCREASE)
O	EM83-03	AIR ASSIST CLOSE VALVE ACTIVATE	8 V @ IDLE (78% DUTY CYCLE)
SS	EM83-05	SENSOR SUPPLY VOLTAGE 2	5 V
SG	EM83-06	SENSOR SHIELD	GROUND
SG	EM83-07	CKPS SIGNAL GROUND	GROUND
I	EM83-08	CKPS SIGNAL	5 V @ 1000 RPM = 45 Hz; 2000 RPM = 90 Hz
SG	EM83-09	CMPS, 'A' BANK SIGNAL GROUND	GROUND
SG	EM83-12	HO2S SHIELD	GROUND
SG	EM83-13	SENSORS SIGNAL GROUND 2	GROUND
I	EM83-14	KNOCK SENSOR, 'A' BANK SIGNAL	0 kHz = NO KNOCK, 2 - 20 kHz = KNOCK
C	EM83-15	CAN NETWORK	15 - 1500 Hz
C	EM83-16	CAN NETWORK	15 - 1500 Hz
SG	EM83-17	CMPS, 'B' BANK SIGNAL GROUND	GROUND
I	EM83-18	CMPS, 'B' BANK SIGNAL	0.7 - 1 VAC @ 1000 RPM = 43 Hz; 2000 RPM = 72 Hz
I	EM83-19	CMPS, 'A' BANK SIGNAL	0.7 - 1 VAC @ 1000 RPM = 43 Hz; 2000 RPM = 72 Hz
I	EM83-20	BATTERY POWER SUPPLY	B+
I	EM83-21	HO2S, 'A' BANK DOWNSTREAM	0.1 - 0.9 V @ IDLE (SWING)
I	EM83-22	HO2S, 'B' BANK DOWNSTREAM	0.1 - 0.9 V @ IDLE (SWING)
I	EM83-23	KNOCK SENSOR, 'B' BANK SIGNAL	0 kHz = NO KNOCK, 2 - 20 kHz = KNOCK
C	EM83-24	CAN NETWORK	15 - 1500 Hz
C	EM83-25	CAN NETWORK	15 - 1500 Hz
SG	EM83-26	MAFS REFERENCE GROUND	GROUND
SG	EM83-27	MAFS REFERENCE GROUND	GROUND
I	EM83-28	MAFS SIGNAL	1.2 V @ IDLE, INCREASING WITH RPM INCREASE
I	EM84-01	GROUND (DOWNSTREAM HO2S HEATERS)	GROUND
O	EM84-07	HO2S HEATER, 'A' BANK DOWNSTREAM CONTROL	GROUND (20 - 60% DUTY CYCLE)
O	EM84-15	HO2S HEATER, 'B' BANK DOWNSTREAM CONTROL	GROUND (20 - 60% DUTY CYCLE)
I	EM84-16	GROUND (INJECTORS 1A, 2B, 3B, 4A)	GROUND
I	EM84-22	GROUND (INJECTORS 1B, 2A, 3A, 4B)	GROUND
O	EM85-01	HO2S HEATER, 'A' BANK UPSTREAM CONTROL	GROUND (85 - 90% DUTY CYCLE AT IDLE)
O	EM85-02	HO2S HEATER, 'B' BANK UPSTREAM CONTROL	GROUND (85 - 90% DUTY CYCLE AT IDLE)
O	EM85-05	"COOL BOX" COOLING FAN ACTIVATE	GROUND
I	EM85-06	GROUND (HO2S A UPSTREAM HEATER)	GROUND
I	EM85-07	GROUND (HO2S B UPSTREAM HEATER)	GROUND
I	EM85-08	HO2S HEATERS OBD MONITOR	HEATERS ACTIVE = B+ V

**NOTE:** Refer to the Appendix at the rear of this book for CAN and SCP Network Messages.

The following abbreviations are used to represent values for Control Module Pin-Out data

I	Input	SG	Sensor Ground	S	SCP Network	V	Voltage (DC)
O	Output	A	ACP Network	D	Serial and Encoded Data	Hz	Frequency
SS	Sensor Supply V	C	CAN (Network)	B+	Battery Voltage	kHz	Frequency x 1000

**CAUTION:** The information on this data page is furnished to aid the user in understanding circuit operation. THIS INFORMATION SHOULD BE USED FOR REFERENCE ONLY.

**NOTE:** The values listed are approximately those that can be expected at the control module connector pins with all circuit connections made and all components connected and fitted. "Active" means a load is applied or a switch is ON; "Inactive" means a load is not applied or a switch is OFF.

## Fig. 04.1

### COMPONENTS

Component	Connector / Type / Color	Location / Access
AIR ASSIST CLOSE VALVE	PI29 / 3-WAY SUMITOMO SS / GREY	ENGINE COMPARTMENT / THROTTLE ASSEMBLY
BRAKE SWITCH	AC24 / 4-WAY MULTILOCK 070 / WHITE	TOP OF BRAKE PEDAL
CCV: CANISTER CLOSE VALVE	BT14 / 2-WAY YAZAKI 090 / BLACK	BEHIND REAR AXLE / RIGHT HAND SIDE
CKPS: CRANKSHAFT POSITION SENSOR	PI17 / 3-WAY ECONOSEAL III LC / BLACK	ENGINE / REAR OF BED PLATE
CMPS: CAMSHAFT POSITION SENSOR - A BANK	PI16 / 2-WAY YAZAKI 090 / BLACK	'A' BANK CYLINDER HEAD, REAR
CMPS: CAMSHAFT POSITION SENSOR - B BANK	PI15 / 2-WAY YAZAKI 090 / BLACK	'B' BANK CYLINDER HEAD, REAR
ECM AND TCM COOLING FAN	EM64 / 2-WAY MULTILOCK 070 / WHITE	ENGINE COMPARTMENT / CONTROL MODULE ENCLOSURE
ECTS: ENGINE COOLANT TEMPERATURE SENSOR	PI4 / 2-WAY ECONOSEAL E J2 / GREY	ENGINE COMPARTMENT / REAR OF ENGINE TOP HOSE
ENGINE CONTROL MODULE	EM80 / 31-WAY AMP 403 / NATURAL EM81 / 24-WAY AMP 403 / NATURAL EM82 / 17-WAY AMP 403 / NATURAL EM83 / 28-WAY AMP 403 / NATURAL EM84 / 22-WAY AMP 403 / NATURAL EM85 / 12-WAY MULTILOCK 070 / WHITE	ENGINE COMPARTMENT / CONTROL MODULE ENCLOSURE
EOTS: ENGINE OIL TEMPERATURE SENSOR	PI38 / 2-WAY ECONOSEAL EC J2 / GREY	ENGINE BLOCK / BELOW GENERATOR
EVAPP: EVAPORATIVE EMISSION CONTROL VALVE	LF58 / 2-WAY ECONOSEAL J2 / BLACK	BEHIND LEFT HAND WHEEL ARCH LINER
FTPS: FUEL TANK PRESSURE SENSOR	FT2 / 3-WAY ECONOSEAL III LC / BLACK	TRUNK / FUEL TANK EVAPORATIVE FLANGE
HO2S: HEATED OXYGEN SENSOR - A DOWNSTREAM	EM22 / 2-WAY SUMITOMO 090 II / BLACK	'A' BANK CATALYTIC CONVERTER
HO2S: HEATED OXYGEN SENSOR - A UPSTREAM	EM21 / 4-WAY SUMITOMO 090 II / GREY	'A' BANK CATALYTIC CONVERTER
HO2S: HEATED OXYGEN SENSOR - B DOWNSTREAM	EM24 / 2-WAY SUMITOMO 090 II / BLACK	'B' BANK CATALYTIC CONVERTER
HO2S: HEATED OXYGEN SENSOR - B UPSTREAM	EM23 / 4-WAY SUMITOMO 090 II / GREY	'B' BANK CATALYTIC CONVERTER
KS: KNOCK SENSOR - A BANK	PI26 / 2-WAY ECONOSEAL III LC / BLACK	ENGINE VEE / UNDER INTAKE MANIFOLD
KS: KNOCK SENSOR - B BANK	PI27 / 2-WAY ECONOSEAL III LC / BLACK	ENGINE VEE / UNDER INTAKE MANIFOLD
MAFS: MASS AIR FLOW SENSOR	PI35 / 5-WAY YAZAKI 0902 / BLACK	ENGINE COMPARTMENT / REARWARD OF AIR CLEANER
PARKING BRAKE SWITCH	FC19 / 1-WAY LUCAR POSILOCK / BLACK	BELOW PARKING BRAKE LEVER
PPS: PEDAL POSITION SENSORS	PI42 / 5-WAY SUMITOMO TS090 / BLACK	ENGINE COMPARTMENT / THROTTLE ASSEMBLY
THROTTLE MOTOR	PI33 / 2-WAY SUMITOMO HM250 / BLACK	ENGINE COMPARTMENT / THROTTLE ASSEMBLY
TPS: THROTTLE POSITION SENSORS	PI6 / 4-WAY ECONOSEAL J2T / BLACK	ENGINE COMPARTMENT / THROTTLE ASSEMBLY
VVT SOLENOID VALVE: VARIABLE VALVE TIMING SOLENOID VALVE - A	PI31 / 2-WAY AMP JUNIOR POWER TIMER / BLACK	ENGINE COMPARTMENT / 'A' BANK CYLINDER HEAD, FRONT
VVT SOLENOID VALVE: VARIABLE VALVE TIMING SOLENOID VALVE - B	PI32 / 2-WAY AMP JUNIOR POWER TIMER / BLACK	ENGINE COMPARTMENT / 'B' BANK CYLINDER HEAD, FRONT

### RELAYS

Relay	Color / Stripe	Connector / Color	Location / Access
THROTTLE MOTOR POWER RELAY	BROWN	EM16 / BROWN	CONTROL MODULE ENCLOSURE RELAYS
O2S HEATERS RELAY	BROWN	EM61 / BROWN	CONTROL MODULE ENCLOSURE RELAYS

### HARNESS-TO-HARNESS CONNECTORS

Connector	Type / Color	Location / Access
AC13	20-WAY MULTILOCK 070 / YELLOW	FASCIA BOTTOM CONNECTOR MOUNTING BRACKET / RIGHT HAND SIDE
BT1	20-WAY MULTILOCK 070 / WHITE	TRUNK / ABOVE RIGHT HAND REAR WHEEL ARCH
BT2	20-WAY MULTILOCK 070 / WHITE	TRUNK / ABOVE RIGHT HAND REAR WHEEL ARCH
EM1	20-WAY MULTILOCK 070 / WHITE	ENGINE COMPARTMENT / ADJACENT TO RIGHT HAND ENCLOSURE
EM2	18-WAY MULTILOCK 070 / YELLOW	ENGINE COMPARTMENT / ADJACENT TO RIGHT HAND ENCLOSURE
EM3	14-WAY MULTILOCK 070 / GREY	ENGINE COMPARTMENT / ADJACENT TO RIGHT HAND ENCLOSURE
FT1	10-WAY MULTILOCK 070 / WHITE	FUEL TANK / REAR
LF3	13-WAY ECONOSEAL III LC / WHITE	LHD: ENGINE COMPARTMENT / ADJACENT TO BRAKE SERVO RHD: ENGINE COMPARTMENT / CONTROL MODULE ENCLOSURE
PI1	57-WAY SUMITOMO TS090 / BLACK	ENGINE COMPARTMENT / BRACKET ON TOP OF TRANSMISSION
PI2	13-WAY ECONOSEAL III LC / BLACK	ENGINE COMPARTMENT / BRACKET ON TOP OF TRANSMISSION
RH1	20-WAY MULTILOCK 070 / GREY	BEHIND GLOVE BOX
RH2	20-WAY MULTILOCK 070 / WHITE	REAR OF CENTER CONSOLE ASSEMBLY

### GROUNDS

Ground	Location / Type
EM1AL	EYELET (PAIR) - LEFT HAND LEG / ENGINE COMPARTMENT, RIGHT HAND ENCLOSURE
EM1AR	EYELET (PAIR) - RIGHT HAND LEG / ENGINE COMPARTMENT, RIGHT HAND ENCLOSURE
EM1BR	EYELET (PAIR) - RIGHT HAND LEG / ENGINE COMPARTMENT, RIGHT HAND ENCLOSURE
EM1BS	EYELET (SINGLE) / ENGINE COMPARTMENT, RIGHT HAND ENCLOSURE
EM2AL	EYELET (PAIR) - LEFT HAND LEG / ENGINE COMPARTMENT, LEFT HAND ENCLOSURE
EM2AR	EYELET (PAIR) - RIGHT HAND LEG / ENGINE COMPARTMENT, LEFT HAND ENCLOSURE
EM2BR	EYELET (PAIR) - RIGHT HAND LEG / ENGINE COMPARTMENT, LEFT HAND ENCLOSURE
EM2BS	EYELET (SINGLE) / ENGINE COMPARTMENT, LEFT HAND ENCLOSURE

FOR CONTROL MODULE PIN OUT INFORMATION, UNFOLD PAGE TO LEFT.

Refer to the front of this book for detailed information and illustrations regarding the location and identification of harnesses, relays, grounds, control modules and control module pins.

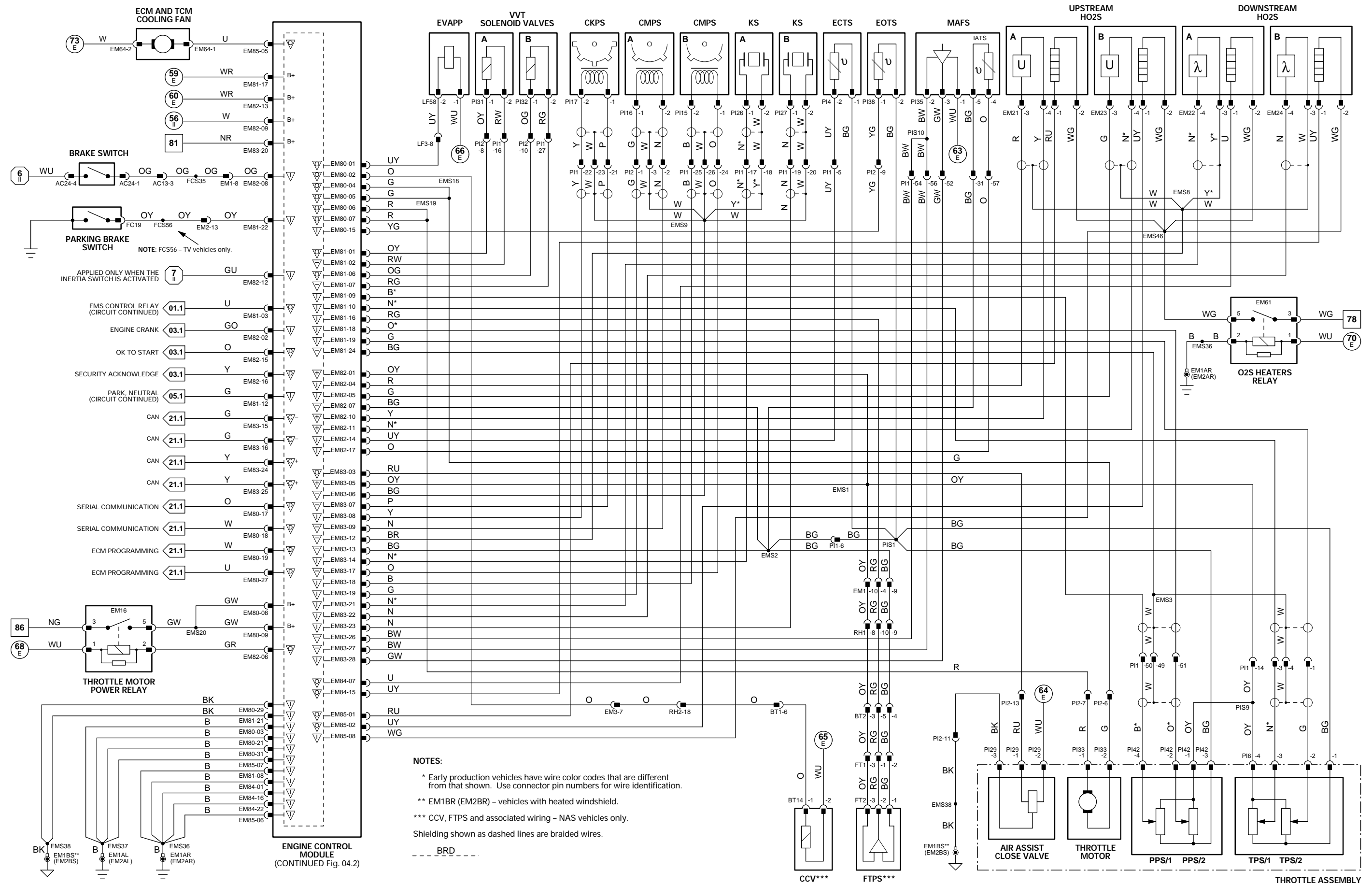

## CONTROL MODULE PIN OUT INFORMATION

### AIR CONDITIONING CONTROL MODULE

Pin	Description	Active
I	AC1-1	COMPRESSOR CLUTCH STATUS
O	AC3-1	AIR CONDITIONING ELECTRICAL LOAD SIGNAL
I	AC4-7	LOAD INHIBIT
O	AC4-9	COMPRESSOR CLUTCH ON REQUEST
I	AC4-17	REFRIGERANT 4-WAY PRESSURE SWITCH

Inactive
0 V
0 V
B+
0 V
B+
0 V (2 - 30 BAR)

### ENGINE CONTROL MODULE

Pin	Description	Active
I	EM80-10	REFRIGERANT 4-WAY PRESSURE SWITCH HIGH PRESSURE
I	EM80-11	A/CCM COMPRESSOR CLUTCH REQUEST
O	EM80-12	ELECTRICAL LOAD INHIBIT
O	EM80-16	SPEED CONTROL ON STATUS LED
I	EM80-20	SPEED CONTROL BRAKE CANCEL REQUEST
I	EM80-22	REFRIGERANT 4-WAY PRESSURE SWITCH HIGH PRESSURE
I	EM80-23	A/CCM ELECTRICAL LOAD REQUEST (HEATED WINDSHIELD)
O	EM80-25	AIR CONDITIONING COMPRESSOR RELAY ACTIVATE
O	EM81-04	PARALLEL (HIGH) SPEED FAN ACTIVATE
O	EM81-05	SERIES (LOW) SPEED FAN ACTIVATE
I	EM81-13	SPEED CONTROL ON REQUEST
I	EM81-14	SPEED CONTROL SET +/-
I	EM81-15	SPEED CONTROL CANCEL / RESUME
O	EM83-04	FUEL PUMP RELAY ACTIVATE
I	EM83-10	IGNITION MODULES 1A, 2B, 3B, 4A OBD MONITOR
I	EM83-11	IGNITION MODULES 1B, 2A, 3A, 4B OBD MONITOR
O	EM84-02	INJECTOR 1A ACTIVATE
O	EM84-03	INJECTOR 3B ACTIVATE
O	EM84-04	INJECTOR 2B ACTIVATE
O	EM84-05	INJECTOR 4A ACTIVATE
O	EM84-06	INJECTOR 1B ACTIVATE
O	EM84-09	IGNITION MODULE 4A SWITCHING
O	EM84-10	IGNITION MODULE 3A SWITCHING
O	EM84-11	IGNITION MODULE 2A SWITCHING
O	EM84-12	IGNITION MODULE 1A SWITCHING
O	EM84-13	INJECTOR 4B ACTIVATE
O	EM84-14	INJECTOR 3A ACTIVATE
O	EM84-17	IGNITION MODULE 4B SWITCHING
O	EM84-18	IGNITION MODULE 3B SWITCHING
O	EM84-19	IGNITION MODULE 2B SWITCHING
O	EM84-20	IGNITION MODULE 1B SWITCHING
O	EM84-21	INJECTOR 2A ACTIVATE

Inactive
GROUND @ 20 BAR (290 PSI)
B+
GROUND
GROUND
GROUND
GROUND @ 12 BAR (174 PSI)
B+
GROUND
GROUND
GROUND
7.3 V = (+), 8.8 V = (-)B+
7.3 V = RESUME, 8.8 V = CANCEL B+
GROUND
23 Hz @ IDLE (5 V)
23 Hz @ IDLE (5 V)
GROUND
GROUND
GROUND
GROUND
GROUND (85 - 90% DUTY CYCLE @ IDLE)
GROUND (85 - 90% DUTY CYCLE @ IDLE)
GROUND (85 - 90% DUTY CYCLE @ IDLE)
GROUND (85 - 90% DUTY CYCLE @ IDLE)
GROUND
GROUND
GROUND (85 - 90% DUTY CYCLE @ IDLE)
GROUND (85 - 90% DUTY CYCLE @ IDLE)
GROUND (85 - 90% DUTY CYCLE @ IDLE)
GROUND (85 - 90% DUTY CYCLE @ IDLE)
GROUND
GROUND

## Fig. 04.2

### COMPONENTS

Component	Connector / Type / Color	Location / Access
AIR CONDITIONING COMPRESSOR CLUTCH	PI36 / 1-WAY SUMITOMO 090 A-TYPE / BLACK	ENGINE COMPARTMENT / A/C COMPRESSOR
AIR CONDITIONING CONTROL MODULE	AC1 / 26-WAY MULTILOCK 47 / GREY AC2 / 16-WAY MULTILOCK 47 / GREY AC3 / 12-WAY MULTILOCK 47 / GREY AC4 / 22-WAY MULTILOCK 47 / GREY AC24 / 4-WAY MULTILOCK 070 / WHITE FC63 / 10-WAY AMP MQL / NATURAL SW3 / 3-WAY EPC / BLACK EM80 / 31-WAY AMP 403 / NATURAL EM81 / 24-WAY AMP 403 / NATURAL EM82 / 17-WAY AMP 403 / NATURAL EM83 / 28-WAY AMP 403 / NATURAL EM84 / 22-WAY AMP 403 / NATURAL EM85 / 12-WAY MULTILOCK 070 / WHITE	A/C UNIT / RIGHT HAND SIDE
BRAKE CANCEL SWITCH	PI7 / 2-WAY AMP JUNIOR POWER TIMER / BLACK	TOP OF BRAKE PEDAL
SPEED CONTROL ON / OFF SWITCH	PI11 / 2-WAY AMP JUNIOR POWER TIMER / BLACK	REARWARD OF GEAR SELECTOR
SPEED CONTROL SWITCHES (STEERING WHEEL)	PI8 / 2-WAY AMP JUNIOR POWER TIMER / BLACK PI12 / 2-WAY AMP JUNIOR POWER TIMER / BLACK PI9 / 2-WAY AMP JUNIOR POWER TIMER / BLACK PI13 / 2-WAY AMP JUNIOR POWER TIMER / BLACK PI10 / 2-WAY AMP JUNIOR POWER TIMER / BLACK PI14 / 2-WAY AMP JUNIOR POWER TIMER / BLACK	CENTER OF STEERING WHEEL
ENGINE CONTROL MODULE	FT3 / 6-WAY SUMITOMO DL090 / NATURAL BT10 / 10-WAY U.T.A. FUSEBOX / NATURAL BT11 / 10-WAY U.T.A. FUSEBOX / BLACK BT12 / 10-WAY U.T.A. FUSEBOX / GREEN BT13 / 10-WAY U.T.A. FUSEBOX / BLUE BT64 / EYELET	ENGINE COMPARTMENT / CONTROL MODULE ENCLOSURE
FUEL INJECTOR - 1A	PI51 / 4-WAY YAZAKI / BLACK	INTAKE MANIFOLD / FUEL RAIL
FUEL INJECTOR - 1B	PI55 / 4-WAY YAZAKI / BLACK	INTAKE MANIFOLD / FUEL RAIL
FUEL INJECTOR - 2A	PI52 / 4-WAY YAZAKI / BLACK	INTAKE MANIFOLD / FUEL RAIL
FUEL INJECTOR - 2B	PI56 / 4-WAY YAZAKI / BLACK	INTAKE MANIFOLD / FUEL RAIL
FUEL INJECTOR - 3A	PI53 / 4-WAY YAZAKI / BLACK	INTAKE MANIFOLD / FUEL RAIL
FUEL INJECTOR - 3B	PI57 / 4-WAY YAZAKI / BLACK	INTAKE MANIFOLD / FUEL RAIL
FUEL INJECTOR - 4A	PI54 / 4-WAY YAZAKI / BLACK	INTAKE MANIFOLD / FUEL RAIL
FUEL INJECTOR - 4B	PI58 / 4-WAY YAZAKI / BLACK	INTAKE MANIFOLD / FUEL RAIL
FUEL PUMP	LF9 / 8-WAY TRW / BLACK	FUEL TANK EVAPORATIVE FLANGE
FUSE BOX - TRUNK	LF13 / 2-WAY REINSHAGEN METRI 630 / BLACK LF12 / 2-WAY REINSHAGEN METRI 630 / BLACK LF57 / 6-WAY ECONOSEAL III LC / BLACK	TRUNK / ELECTRICAL CARRIER
IGNITION COIL - 1A	PI51 / 4-WAY YAZAKI / BLACK	ENGINE COMPARTMENT / CAMSHAFT COVER
IGNITION COIL - 1B	PI55 / 4-WAY YAZAKI / BLACK	ENGINE COMPARTMENT / CAMSHAFT COVER
IGNITION COIL - 2A	PI52 / 4-WAY YAZAKI / BLACK	ENGINE COMPARTMENT / CAMSHAFT COVER
IGNITION COIL - 2B	PI56 / 4-WAY YAZAKI / BLACK	ENGINE COMPARTMENT / CAMSHAFT COVER
IGNITION COIL - 3A	PI53 / 4-WAY YAZAKI / BLACK	ENGINE COMPARTMENT / CAMSHAFT COVER
IGNITION COIL - 3B	PI57 / 4-WAY YAZAKI / BLACK	ENGINE COMPARTMENT / CAMSHAFT COVER
IGNITION COIL - 4A	PI54 / 4-WAY YAZAKI / BLACK	ENGINE COMPARTMENT / CAMSHAFT COVER
IGNITION COIL - 4B	PI58 / 4-WAY YAZAKI / BLACK	ENGINE COMPARTMENT / CAMSHAFT COVER
RADIATOR FAN CONTROL RELAY MODULE	LF9 / 8-WAY TRW / BLACK	ADJACENT TO LEFT HAND HORN
RADIATOR FAN - LH	LF13 / 2-WAY REINSHAGEN METRI 630 / BLACK	ENGINE COMPARTMENT / FRONT
RADIATOR FAN - RH	LF12 / 2-WAY REINSHAGEN METRI 630 / BLACK	ENGINE COMPARTMENT / FRONT
REFRIGERANT 4-WAY PRESSURE SWITCH	LF57 / 6-WAY ECONOSEAL III LC / BLACK	ENGINE COMPARTMENT / REARWARD OF RADIATOR

### RELAYS

Relay	Color / Stripe	Connector / Color	Location / Access
AIR CONDITIONING COMPRESSOR CLUTCH RELAY	BROWN	EM17	LH ENCLOSURE RELAYS
FUEL INJECTION RELAY	BROWN	EM5 / BROWN	CONTROL MODULE ENCLOSURE RELAYS
FUEL PUMP RELAY (#4)	BROWN	BUS	TRUNK FUSE BOX
IGNITION COIL RELAY	BROWN	EM26 / BROWN	CONTROL MODULE ENCLOSURE RELAYS

### HARNESS-TO-HARNESS CONNECTORS

Connector	Type / Color	Location / Access
AC12	20-WAY MULTILOCK 070 / WHITE	FASCIA TOP CONNECTOR MOUNTING BRACKET / RIGHT HAND SIDE
AC13	20-WAY MULTILOCK 070 / YELLOW	FASCIA BOTTOM CONNECTOR MOUNTING BRACKET / RIGHT HAND SIDE
BT2	20-WAY MULTILOCK 070 / WHITE	TRUNK / ABOVE RIGHT HAND REAR WHEEL ARCH
EM1	20-WAY MULTILOCK 070 / WHITE	ENGINE COMPARTMENT / ADJACENT TO RIGHT HAND ENCLOSURE
EM2	18-WAY MULTILOCK 070 / YELLOW	ENGINE COMPARTMENT / ADJACENT TO RIGHT HAND ENCLOSURE
EM3	14-WAY MULTILOCK 070 / GREY	ENGINE COMPARTMENT / ADJACENT TO RIGHT HAND ENCLOSURE
FT1	10-WAY MULTILOCK 070 / WHITE	FUEL TANK / REAR
LF3	13-WAY ECONOSEAL III LC / WHITE	LHD: ENGINE COMPARTMENT / ADJACENT TO BRAKE SERVO RHD: ENGINE COMPARTMENT / CONTROL MODULE ENCLOSURE
LF40	13-WAY ECONOSEAL III LC / BLACK	LHD: ENGINE COMPARTMENT / FORWARD OF BRAKE FLUID RESERVOIR RHD: ENGINE COMPARTMENT / BELOW CONTROL MODULE ENCLOSURE
PI1	57-WAY SUMITOMO TS090 / BLACK	ENGINE COMPARTMENT / BRACKET ON TOP OF TRANSMISSION
PI2	13-WAY ECONOSEAL III LC / BLACK	ENGINE COMPARTMENT / BRACKET ON TOP OF TRANSMISSION
RH1	20-WAY MULTILOCK 070 / GREY	BEHIND GLOVE BOX
SC3	12-WAY MULTILOCK 070 / GREY	RIGHT HAND SIDE OF STEERING COLUMN
SW1	12-WAY MULTILOCK 040 / BLACK	INSIDE STEERING COLUMN COWL
SW2	6-WAY JST / WHITE	CENTER OF STEERING WHEEL

### GROUND

Ground	Location / Type
BT2AL	EYELET (PAIR) - LEFT HAND LEG / TRUNK, RIGHT REAR
EM1AL	EYELET (PAIR) - LEFT HAND LEG / ENGINE COMPARTMENT, RIGHT HAND ENCLOSURE
EM1AR	EYELET (PAIR) - RIGHT HAND LEG / ENGINE COMPARTMENT, RIGHT HAND ENCLOSURE
EM2AL	EYELET (PAIR) - LEFT HAND LEG / ENGINE COMPARTMENT, LEFT HAND ENCLOSURE
EM2AR	EYELET (PAIR) - RIGHT HAND LEG / ENGINE COMPARTMENT, LEFT HAND ENCLOSURE
FC3BL	EYELET (PAIR) - LEFT HAND LEG / TRANSMISSION TUNNEL, LEFT HAND SIDE
LF2AL	EYELET (PAIR) - LEFT HAND LEG / ENGINE COMPARTMENT, FORWARD OF LEFT HAND HOOD CATCH
LF2AR	EYELET (PAIR) - RIGHT HAND LEG / ENGINE COMPARTMENT, FORWARD OF LEFT HAND HOOD CATCH
LF2BL	EYELET (PAIR) - LEFT HAND LEG / ENGINE COMPARTMENT, FORWARD OF LEFT HAND HOOD CATCH

The following abbreviations are used to represent values for Control Module Pin-Out data

I	Input	SG	Sensor Ground	S	SCP Network	V	Voltage (DC)
O	Output	A	ACP Network	D	Serial and Encoded Data	Hz	Frequency
SS	Sensor Supply V	C	CAN (Network)	B+	Battery Voltage	kHz	Frequency x 1000

**CAUTION:** The information on this data page is furnished to aid the user in understanding circuit operation. THIS INFORMATION SHOULD BE USED FOR REFERENCE ONLY.

**NOTE:** The values listed are approximately those that can be expected at the control module connector pins with all circuit connections made and all components connected and fitted. "Active" means a load is applied or a switch is ON; "Inactive" means a load is not applied or a switch is OFF.

FOR CONTROL MODULE PIN OUT INFORMATION, UNFOLD PAGE TO LEFT.

Refer to the front of this book for detailed information and illustrations regarding the location and identification of harnesses, relays, grounds, control modules and control module pins.

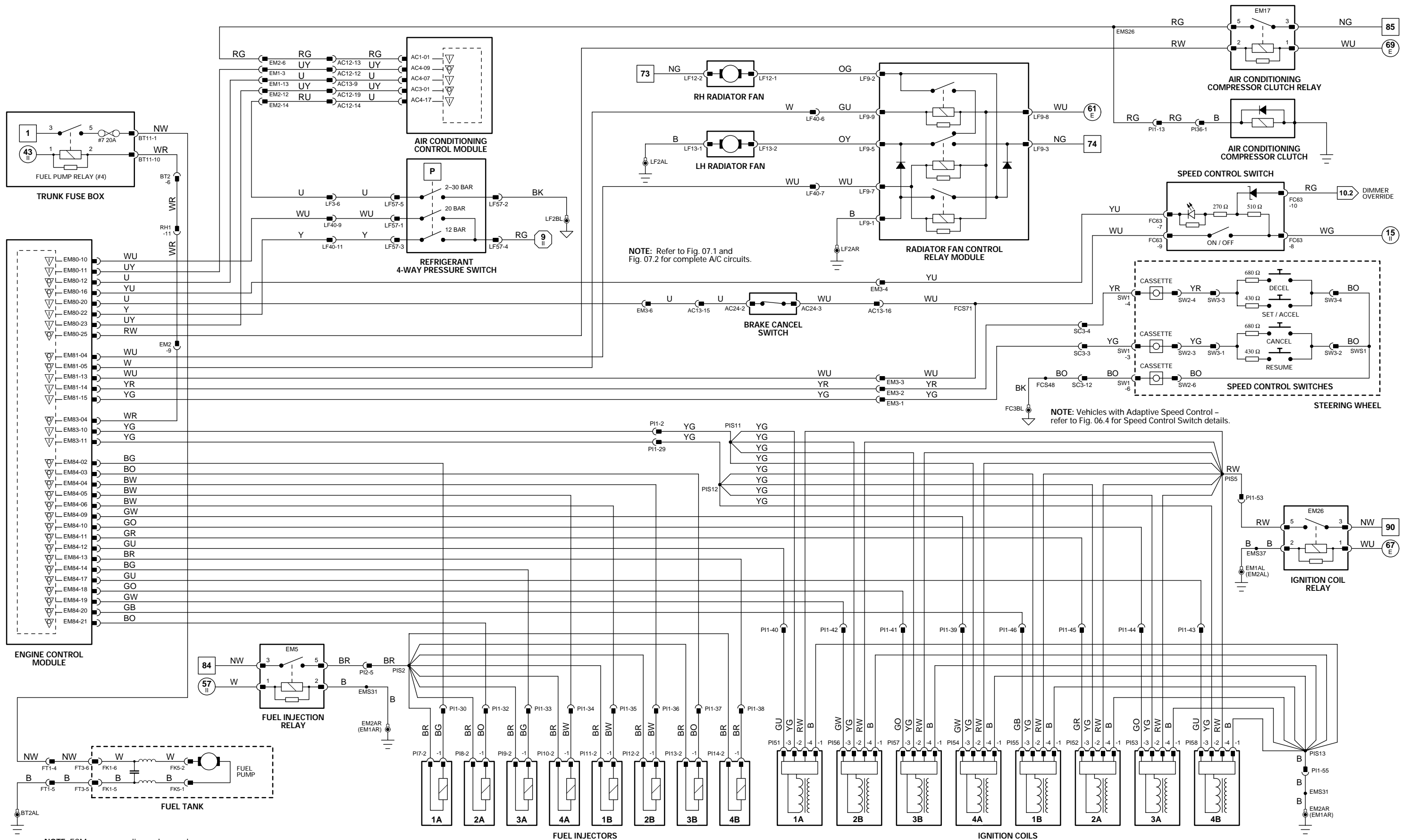

NOTE: Refer to Fig. 07.1 and Fig. 07.2 for complete A/C circuits.

NOTE: Vehicles with Adaptive Speed Control - refer to Fig. 06.4 for Speed Control Switch details.

NOTE: ECM power supplies and grounds shown on Fig. 04.1.

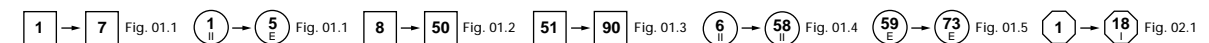

VARIANT: AJ27 N/A Vehicles  
 VIN RANGE: A11051 →  
 DATE OF ISSUE: September 2000

**CONTROL MODULE PIN OUT INFORMATION**

**ENGINE CONTROL MODULE**

Pin	Description	Active	Inactive
O	EM80-01	EVAP VALVE ACTIVATE	GROUND (VALVE OPEN)
O	EM80-02	CANISTER CLOSE VALVE ACTIVATE	GROUND
I	EM80-03	GROUND (POWER)	GROUND
O	EM80-04	THROTTLE MOTOR POWER SUPPLY	B+
O	EM80-05	THROTTLE MOTOR POWER SUPPLY	B+
O	EM80-06	THROTTLE MOTOR POWER SUPPLY	B+
O	EM80-07	THROTTLE MOTOR POWER SUPPLY	B+
I	EM80-08	THROTTLE MOTOR POWER SUPPLY	B+
I	EM80-09	THROTTLE MOTOR POWER SUPPLY	B+
I	EM80-15	EOT SIGNAL	2.5 V @ 34 °C; 0.5 V @ 90 °C; (DECREASING VOLTAGE WITH TEMPERATURE INCREASE)
D	EM80-17	SERIAL COMMUNICATIONS	
D	EM80-18	SERIAL COMMUNICATIONS	
D	EM80-19	ECM PROGRAMMING	
I	EM80-21	GROUND (THROTTLE MOTOR 1)	GROUND
D	EM80-27	ECM PROGRAMMING	
I	EM80-28	MAPS SIGNAL	1.2 V = IDLE; 3.6 V = ENGINE SWITCHED OFF
I	EM80-29	GROUND (LOGIC 2)	GROUND
I	EM80-31	GROUND (THROTTLE MOTOR 2)	GROUND
O	EM81-03	EMS CONTROLLED RELAY ACTIVATE	GROUND
I	EM81-08	GROUND (POWER)	GROUND
I	EM81-09	PEDAL POSITION SIGNAL (PPS/1)	0.8 V = FOOT OFF; 3.8 V = PEDAL FULLY DEPRESSED
I	EM81-10	TPS SIGNAL (TPS/1)	0.5 V = IDLE; 4.75 V = WOT
I	EM81-12	PARK / NEUTRAL CONFIRMATION	B+ (P, N)
I	EM81-16	FUEL TANK PRESSURE SENSOR SIGNAL	4.9 V = LOW PRESSURE, 0.2 V = HIGH PRESSURE
I	EM81-17	EMS SWITCHED POWER SUPPLY 1	B+
I	EM81-18	PEDAL POSITION SIGNAL (PPS/2)	0.8 V = FOOT OFF; 2.4 V = PEDAL FULLY DEPRESSED
I	EM81-19	TPS SIGNAL (TPS/2)	0.6 V = IDLE; 4.85 V = WOT
I	EM81-21	GROUND (LOGIC 1)	GROUND
I	EM81-22	PARKING BRAKE SWITCH	GROUND (APPLIED)
I	EM81-23	IATS 2 SIGNAL	2.38 V @ 20 °C, (DECREASING VOLTAGE WITH TEMPERATURE INCREASE)
SG	EM81-24	PEDAL POSITION / THROTTLE POSITION SENSORS SHIELD	GROUND
SS	EM82-01	SENSOR SUPPLY VOLTAGE 1	5 V
I	EM82-02	ENGINE CRANK	GROUND (CRANKING)
I	EM82-04	HO2S, UPSTREAM 'A' BANK – VARIABLE CURRENT (µA)	3.5 V
I	EM82-05	HO2S, UPSTREAM 'B' BANK – VARIABLE CURRENT (µA)	3.5 V
O	EM82-06	THROTTLE MOTOR POWER RELAY ACTIVATE	GROUND
SG	EM82-07	SENSORS SIGNAL GROUND 1	GROUND
I	EM82-08	BRAKE SWITCH	GROUND
I	EM82-09	IGNITION SWITCHED POWER SUPPLY	B+
SS	EM82-10	HO2S, UPSTREAM 'A' BANK – CONSTANT	3.8 V
SS	EM82-11	HO2S, UPSTREAM 'B' BANK – CONSTANT	3.8 V
I	EM82-12	INERTIA SWITCH ACTIVATED (VEHICLE IMPACT)	GROUND
I	EM82-13	EMS SWITCHED POWER SUPPLY 2	B+
I	EM82-14	ECT SIGNAL	0.41 V @ 90 °C (DECREASING VOLTAGE WITH TEMPERATURE INCREASE)
D	EM82-15	OK TO START	ENCODED COMMUNICATIONS
D	EM82-16	SECURITY ACKNOWLEDGE	ENCODED COMMUNICATIONS
I	EM82-17	IATS SIGNAL	0.98 V @ 10 °C, (DECREASING VOLTAGE WITH TEMPERATURE INCREASE)
SS	EM83-05	SENSOR SUPPLY VOLTAGE 2	5 V
SG	EM83-06	SENSOR SHIELD	GROUND
SG	EM83-07	CKPS SIGNAL GROUND	GROUND
I	EM83-08	CKPS SIGNAL	5 V @ 1000 RPM = 45 Hz; 2000 RPM = 90 Hz
SG	EM83-09	CMPS, 'A' BANK SIGNAL GROUND	GROUND
SG	EM83-12	HO2S SHIELD	GROUND
SG	EM83-13	SENSORS SIGNAL GROUND 2	GROUND
I	EM83-14	KNOCK SENSOR, 'A' BANK SIGNAL	0 kHz = NO KNOCK, 2 – 20 kHz = KNOCK
C	EM83-15	CAN NETWORK	15 – 1500 Hz
C	EM83-16	CAN NETWORK	15 – 1500 Hz
SG	EM83-17	CMPS, 'B' BANK SIGNAL GROUND	GROUND
I	EM83-18	CMPS, 'B' BANK SIGNAL	0.7 – 1 VAC @ 1000 RPM = 43 Hz; 2000 RPM = 72 Hz
I	EM83-19	CMPS, 'A' BANK SIGNAL	0.7 – 1 VAC @ 1000 RPM = 43 Hz; 2000 RPM = 72 Hz
I	EM83-20	BATTERY POWER SUPPLY	B+
I	EM83-21	HO2S, 'A' BANK DOWNSTREAM	0.1 – 0.9 V @ IDLE (SWING)
I	EM83-22	HO2S, 'B' BANK DOWNSTREAM	0.1 – 0.9 V @ IDLE (SWING)
I	EM83-23	KNOCK SENSOR, 'B' BANK SIGNAL	0 kHz = NO KNOCK, 2 – 20 kHz = KNOCK
C	EM83-24	CAN NETWORK	15 – 1500 Hz
C	EM83-25	CAN NETWORK	15 – 1500 Hz
SG	EM83-26	MAFS REFERENCE GROUND	GROUND
SG	EM83-27	MAFS REFERENCE GROUND	GROUND
I	EM83-28	MAFS SIGNAL	1.2 V @ IDLE, INCREASING WITH RPM INCREASE
I	EM84-01	GROUND (DOWNSTREAM HO2S HEATERS)	GROUND
O	EM84-07	HO2S HEATER, 'A' BANK DOWNSTREAM CONTROL	GROUND (20 – 60% DUTY CYCLE)
O	EM84-15	HO2S HEATER, 'B' BANK DOWNSTREAM CONTROL	GROUND (20 – 60% DUTY CYCLE)
I	EM84-16	GROUND (INJECTORS 1A, 2B, 3B, 4A)	GROUND
I	EM84-22	GROUND (INJECTORS 1B, 2A, 3A, 4B)	GROUND
O	EM85-01	HO2S HEATER, 'A' BANK UPSTREAM CONTROL	GROUND (85 – 90% DUTY CYCLE AT IDLE)
O	EM85-02	HO2S HEATER, 'B' BANK UPSTREAM CONTROL	GROUND (85 – 90% DUTY CYCLE AT IDLE)
O	EM85-03	EGR STEPPER MOTOR 'S1' WINDING SUPPLY	GROUND
O	EM85-04	EGR STEPPER MOTOR 'S2' WINDING SUPPLY	GROUND
O	EM85-05	"COOL BOX" COOLING FAN ACTIVATE	GROUND
I	EM85-06	GROUND (HO2S A UPSTREAM HEATER)	GROUND
I	EM85-07	GROUND (HO2S B UPSTREAM HEATER)	GROUND
I	EM85-08	HO2S HEATERS OBD MONITOR	HEATERS ACTIVE = B+ V
O	EM85-09	EGR STEPPER MOTOR 'S3' WINDING SUPPLY	GROUND
O	EM85-10	EGR STEPPER MOTOR 'S4' WINDING SUPPLY	GROUND

**NOTE:** Refer to the Appendix at the rear of this book for CAN and SCP Network Messages.

The following abbreviations are used to represent values for Control Module Pin-Out data

<b>I</b>	<b>Input</b>	<b>SG</b>	<b>Sensor Ground</b>	<b>S</b>	<b>SCP Network</b>	<b>V</b>	<b>Voltage (DC)</b>
<b>O</b>	<b>Output</b>	<b>A</b>	<b>ACP Network</b>	<b>D</b>	<b>Serial and Encoded Data</b>	<b>Hz</b>	<b>Frequency</b>
<b>SS</b>	<b>Sensor Supply V</b>	<b>C</b>	<b>CAN (Network)</b>	<b>B+</b>	<b>Battery Voltage</b>	<b>kHz</b>	<b>Frequency x 1000</b>

**CAUTION:** The information on this data page is furnished to aid the user in understanding circuit operation. THIS INFORMATION SHOULD BE USED FOR REFERENCE ONLY.

**NOTE:** The values listed are approximately those that can be expected at the control module connector pins with all circuit connections made and all components connected and fitted. "Active" means a load is applied or a switch is ON; "Inactive" means a load is not applied or a switch is OFF.

**Fig. 04.3**

**COMPONENTS**

Component	Connector / Type / Color	Location / Access
BRAKE SWITCH	AC24 / 4-WAY MULTILOCK 070 / WHITE	TOP OF BRAKE PEDAL
CCV: CANISTER CLOSE VALVE	BT14 / 2-WAY YAZAKI 090 / BLACK	BEHIND REAR AXLE / RIGHT HAND SIDE
CKPS: CRANKSHAFT POSITION SENSOR	PI17 / 3-WAY ECONOSEAL III LC / BLACK	ENGINE / REAR OF BED PLATE
CMPS: CAMSHAFT POSITION SENSOR – A BANK	PI16 / 2-WAY YAZAKI 090 / BLACK	'A' BANK CYLINDER HEAD, REAR
CMPS: CAMSHAFT POSITION SENSOR – B BANK	PI15 / 2-WAY YAZAKI 090 / BLACK	'B' BANK CYLINDER HEAD, REAR
ECM AND TCM COOLING FAN	EM64 / 2-WAY MULTILOCK 070 / WHITE	ENGINE COMPARTMENT / CONTROL MODULE ENCLOSURE
ECTS: ENGINE COOLANT TEMPERATURE SENSOR	PI4 / 2-WAY ECONOSEAL E J2 / GREY	ENGINE COMPARTMENT / REAR OF ENGINE TOP HOSE
EGR VALVE	PI34 / 6-WAY / SUMITOMO 92 / GREY	ENGINE COMPARTMENT / REAR OF THROTTLE ASSEMBLY
ENGINE CONTROL MODULE	EM80 / 31-WAY AMP 403 / NATURAL EM81 / 24-WAY AMP 403 / NATURAL EM82 / 17-WAY AMP 403 / NATURAL EM83 / 28-WAY AMP 403 / NATURAL EM84 / 22-WAY AMP 403 / NATURAL EM85 / 12-WAY MULTILOCK 070 / WHITE	ENGINE COMPARTMENT / CONTROL MODULE ENCLOSURE
EOTS: ENGINE OIL TEMPERATURE SENSOR	PI38 / 2-WAY ECONOSEAL EC J2 / GREY	ENGINE BLOCK / BELOW GENERATOR
EVAPP: EVAPORATIVE EMISSION CONTROL VALVE	LF58 / 2-WAY ECONOSEAL J2 / BLACK	BEHIND LEFT HAND WHEEL ARCH LINER
FTPS: FUEL TANK PRESSURE SENSOR	FT2 / 3-WAY ECONOSEAL III LC / BLACK	TRUNK / FUEL TANK EVAPORATIVE FLANGE
HO2S: HEATED OXYGEN SENSOR – A DOWNSTREAM	EM22 / 2-WAY SUMITOMO 090 II / BLACK	'A' BANK CATALYTIC CONVERTER
HO2S: HEATED OXYGEN SENSOR – A UPSTREAM	EM21 / 4-WAY SUMITOMO 090 II / GREY	'A' BANK CATALYTIC CONVERTER
HO2S: HEATED OXYGEN SENSOR – B DOWNSTREAM	EM24 / 2-WAY SUMITOMO 090 II / BLACK	'B' BANK CATALYTIC CONVERTER
HO2S: HEATED OXYGEN SENSOR – B UPSTREAM	EM23 / 4-WAY SUMITOMO 090 II / GREY	'B' BANK CATALYTIC CONVERTER
IATS 2: INTAKE AIR TEMPERATURE SENSOR 2	PI3 / 2-WAY AMP JUNIOR POWER TIMER / BLACK	ENGINE COMPARTMENT / 'A' BANK INTERCOOLER / REAR
KS: KNOCK SENSOR – A BANK	PI26 / 2-WAY ECONOSEAL III LC / BLACK	ENGINE VEE / UNDER INTAKE MANIFOLD
KS: KNOCK SENSOR – B BANK	PI27 / 2-WAY ECONOSEAL III LC / BLACK	ENGINE VEE / UNDER INTAKE MANIFOLD
MAFS: MASS AIR FLOW SENSOR	PI35 / 5-WAY YAZAKI 0902 / BLACK	ENGINE COMPARTMENT / REARWARD OF AIR CLEANER
MAPS: MANIFOLD ABSOLUTE PRESSURE SENSOR	EM10 / 3-WAY SUMITOMO / BLACK	ENGINE COMPARTMENT / CONTROL MODULE ENCLOSURE
PPS: PEDAL POSITION SENSORS	PI42 / 5-WAY SUMITOMO TS090 / BLACK	ENGINE COMPARTMENT / THROTTLE ASSEMBLY
THROTTLE MOTOR	PI33 / 2-WAY SUMITOMO HM250 / BLACK	ENGINE COMPARTMENT / THROTTLE ASSEMBLY
TPS: THROTTLE POSITION SENSORS	PI6 / 4-WAY ECONOSEAL J2T / BLACK	ENGINE COMPARTMENT / THROTTLE ASSEMBLY

**RELAYS**

Relay	Color / Stripe	Connector / Color	Location / Access
O2S HEATERS RELAY	BROWN	EM61 / BROWN	CONTROL MODULE ENCLOSURE RELAYS
THROTTLE MOTOR POWER RELAY	BROWN	EM16 / BROWN	CONTROL MODULE ENCLOSURE RELAYS

**HARNESSTO-HARNESSTO CONNECTORS**

Connector	Type / Color	Location / Access
AC13	20-WAY MULTILOCK 070 / YELLOW	FASCIA BOTTOM CONNECTOR MOUNTING BRACKET / RIGHT HAND SIDE
BT1	20-WAY MULTILOCK 070 / WHITE	TRUNK / ABOVE RIGHT HAND REAR WHEEL ARCH
BT2	20-WAY MULTILOCK 070 / WHITE	TRUNK / ABOVE RIGHT HAND REAR WHEEL ARCH
EM1	20-WAY MULTILOCK 070 / WHITE	ENGINE COMPARTMENT / ADJACENT TO RIGHT HAND ENCLOSURE
EM2	18-WAY MULTILOCK 070 / YELLOW	ENGINE COMPARTMENT / ADJACENT TO RIGHT HAND ENCLOSURE
EM3	14-WAY MULTILOCK 070 / GREY	ENGINE COMPARTMENT / ADJACENT TO RIGHT HAND ENCLOSURE
FT1	10-WAY MULTILOCK 070 / WHITE	FUEL TANK / REAR
LF3	13-WAY ECONOSEAL III LC / WHITE	LHD: ENGINE COMPARTMENT / ADJACENT TO BRAKE SERVO RHD: ENGINE COMPARTMENT / CONTROL MODULE ENCLOSURE
PI1	57-WAY SUMITOMO TS090 / BLACK	ENGINE COMPARTMENT / BRACKET ON TOP OF TRANSMISSION
PI2	13-WAY ECONOSEAL III LC / BLACK	ENGINE COMPARTMENT / BRACKET ON TOP OF TRANSMISSION
RH1	20-WAY MULTILOCK 070 / GREY	BEHIND GLOVE BOX
RH2	20-WAY MULTILOCK 070 / WHITE	REAR OF CENTER CONSOLE ASSEMBLY

**GROUNDS**

Ground	Location / Type
EM1AL	EYELET (PAIR) – LEFT HAND LEG / ENGINE COMPARTMENT, RIGHT HAND ENCLOSURE
EM1AR	EYELET (PAIR) – RIGHT HAND LEG / ENGINE COMPARTMENT, RIGHT HAND ENCLOSURE
EM1BR	EYELET (PAIR) – RIGHT HAND LEG / ENGINE COMPARTMENT, RIGHT HAND ENCLOSURE
EM1BS	EYELET (SINGLE) / ENGINE COMPARTMENT, RIGHT HAND ENCLOSURE
EM2AL	EYELET (PAIR) – LEFT HAND LEG / ENGINE COMPARTMENT, LEFT HAND ENCLOSURE
EM2AR	EYELET (PAIR) – RIGHT HAND LEG / ENGINE COMPARTMENT, LEFT HAND ENCLOSURE
EM2BR	EYELET (PAIR) – RIGHT HAND LEG / ENGINE COMPARTMENT, LEFT HAND ENCLOSURE
EM2BS	EYELET (SINGLE) / ENGINE COMPARTMENT, LEFT HAND ENCLOSURE

**FOR CONTROL MODULE PIN OUT INFORMATION, UNFOLD PAGE TO LEFT.**

Refer to the front of this book for detailed information and illustrations regarding the location and identification of harnesses, relays, grounds, control modules and control module pins.

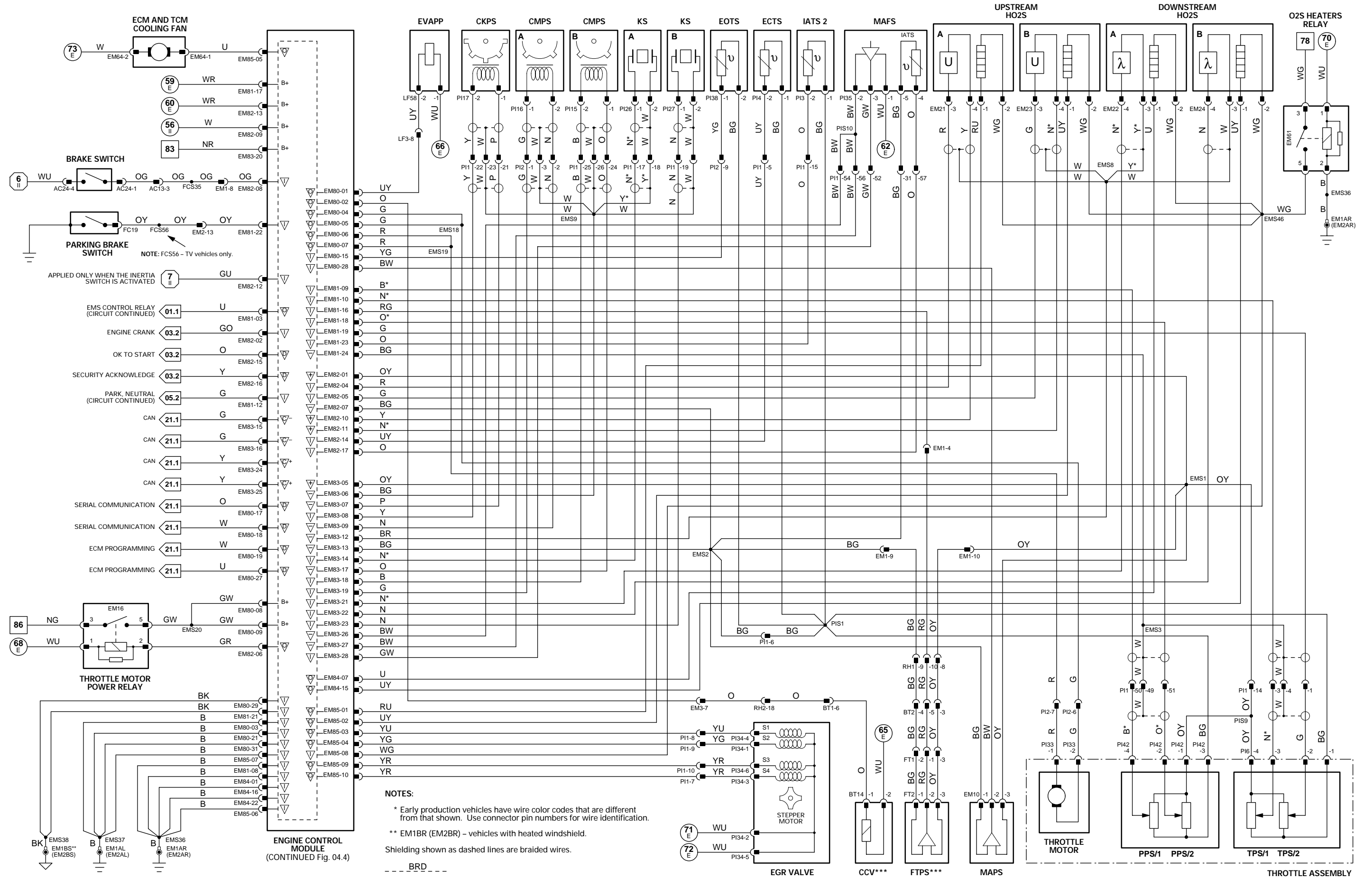

**NOTES:**

- \* Early production vehicles have wire color codes that are different from that shown. Use connector pin numbers for wire identification.
- \*\* EM1BR (EM2BR) – vehicles with heated windshield.

Shielding shown as dashed lines are braided wires.

--- BRD ---

## CONTROL MODULE PIN OUT INFORMATION

### AIR CONDITIONING CONTROL MODULE

Pin	Description	Active	Inactive
I AC1-1	COMPRESSOR CLUTCH STATUS	B+ (ON)	0 V
O AC3-1	AIR CONDITIONING ELECTRICAL LOAD SIGNAL	B+	0 V
I AC4-7	LOAD INHIBIT	0 V	B+
O AC4-9	COMPRESSOR CLUTCH ON REQUEST	B+	0 V
I AC4-17	REFRIGERANT 4-WAY PRESSURE SWITCH	0 V (2 – 30 BAR)	B+ (OUT OF ACTIVE RANGE)

### ENGINE CONTROL MODULE

Pin	Description	Active	Inactive
I EM80-10	REFRIGERANT 4-WAY PRESSURE SWITCH HIGH PRESSURE	GROUND @ 20 BAR (290 PSI)	
I EM80-11	A/CCM COMPRESSOR CLUTCH REQUEST	B+	GROUND
O EM80-12	ELECTRICAL LOAD INHIBIT	GROUND	B+
O EM80-14	INTERCOOLER PUMP RELAY ACTIVATE	GROUND	B+
O EM80-16	SPEED CONTROL ON STATUS LED	GROUND	B+
I EM80-20	SPEED CONTROL BRAKE CANCEL REQUEST	GROUND	B+
I EM80-22	REFRIGERANT 4-WAY PRESSURE SWITCH HIGH PRESSURE	GROUND @ 12 BAR (174 PSI)	
I EM80-23	A/CCM ELECTRICAL LOAD REQUEST (HEATED WINDSHIELD)	B+	GROUND
O EM80-25	AIR CONDITIONING COMPRESSOR RELAY ACTIVATE	GROUND	B+
O EM81-04	PARALLEL (HIGH) SPEED FAN ACTIVATE	GROUND	B+
O EM81-05	SERIES (LOW) SPEED FAN ACTIVATE	GROUND	B+
I EM81-13	SPEED CONTROL ON REQUEST	B+	GROUND
I EM81-14	SPEED CONTROL SET +/-	7.3 V = (+), 8.8 V = (-)B+	
I EM81-15	SPEED CONTROL CANCEL / RESUME	7.3 V = RESUME, 8.8 V = CANCEL B+	
O EM82-03	FUEL PUMP RELAY 2 ACTIVATE	GROUND	B+
O EM83-04	FUEL PUMP RELAY ACTIVATE	GROUND	B+
I EM83-10	IGNITION MODULES 1A, 2B, 3B, 4A OBD MONITOR	23 Hz @ IDLE (5 V)	
I EM83-11	IGNITION MODULES 1B, 2A, 3A, 4B OBD MONITOR	23 Hz @ IDLE (5 V)	
O EM84-02	INJECTOR 1A ACTIVATE	GROUND	B+
O EM84-03	INJECTOR 3B ACTIVATE	GROUND	B+
O EM84-04	INJECTOR 2B ACTIVATE	GROUND	B+
O EM84-05	INJECTOR 4A ACTIVATE	GROUND	B+
O EM84-06	INJECTOR 1B ACTIVATE	GROUND	B+
O EM84-09	IGNITION MODULE 4A SWITCHING	GROUND (85 – 90% DUTY CYCLE @ IDLE)	B+
O EM84-10	IGNITION MODULE 3A SWITCHING	GROUND (85 – 90% DUTY CYCLE @ IDLE)	B+
O EM84-11	IGNITION MODULE 2A SWITCHING	GROUND (85 – 90% DUTY CYCLE @ IDLE)	B+
O EM84-12	IGNITION MODULE 1A SWITCHING	GROUND (85 – 90% DUTY CYCLE @ IDLE)	B+
O EM84-13	INJECTOR 4B ACTIVATE	GROUND	B+
O EM84-14	INJECTOR 3A ACTIVATE	GROUND	B+
O EM84-17	IGNITION MODULE 4B SWITCHING	GROUND (85 – 90% DUTY CYCLE @ IDLE)	B+
O EM84-18	IGNITION MODULE 3B SWITCHING	GROUND (85 – 90% DUTY CYCLE @ IDLE)	B+
O EM84-19	IGNITION MODULE 2B SWITCHING	GROUND (85 – 90% DUTY CYCLE @ IDLE)	B+
O EM84-20	IGNITION MODULE 1B SWITCHING	GROUND (85 – 90% DUTY CYCLE @ IDLE)	B+
O EM84-21	INJECTOR 2A ACTIVATE	GROUND	B+

## Fig. 04.4

### COMPONENTS

Component	Connector / Type / Color	Location / Access
AIR CONDITIONING COMPRESSOR CLUTCH	PI36 / 1-WAY SUMITOMO 090 A-TYPE / BLACK	ENGINE COMPARTMENT / A/C COMPRESSOR
AIR CONDITIONING CONTROL MODULE	AC1 / 26-WAY MULTILOCK 47 / GREY AC2 / 16-WAY MULTILOCK 47 / GREY AC3 / 12-WAY MULTILOCK 47 / GREY AC4 / 22-WAY MULTILOCK 47 / GREY AC24 / 4-WAY MULTILOCK 070 / WHITE	A/C UNIT / RIGHT HAND SIDE
BRAKE CANCEL SWITCH	FC63 / 10-WAY AMP MQL / NATURAL	TOP OF BRAKE PEDAL
SPEED CONTROL ON / OFF SWITCH	SW3 / 3-WAY EPC / BLACK	REARWARD OF GEAR SELECTOR
SPEED CONTROL SWITCHES (STEERING WHEEL)	EM80 / 31-WAY AMP 403 / NATURAL EM81 / 24-WAY AMP 403 / NATURAL EM82 / 17-WAY AMP 403 / NATURAL EM83 / 28-WAY AMP 403 / NATURAL EM84 / 22-WAY AMP 403 / NATURAL EM85 / 12-WAY MULTILOCK 070 / WHITE	CENTER OF STEERING WHEEL ENGINE COMPARTMENT / CONTROL MODULE ENCLOSURE
ENGINE CONTROL MODULE	IJ3 / 2-WAY AMP JUNIOR POWER TIMER / BLACK IJ7 / 2-WAY AMP JUNIOR POWER TIMER / BLACK IJ4 / 2-WAY AMP JUNIOR POWER TIMER / BLACK IJ8 / 2-WAY AMP JUNIOR POWER TIMER / BLACK IJ5 / 2-WAY AMP JUNIOR POWER TIMER / BLACK IJ9 / 2-WAY AMP JUNIOR POWER TIMER / BLACK IJ6 / 2-WAY AMP JUNIOR POWER TIMER / BLACK IJ10 / 2-WAY AMP JUNIOR POWER TIMER / BLACK	INTAKE MANIFOLD / FUEL RAIL INTAKE MANIFOLD / FUEL RAIL INTAKE MANIFOLD / FUEL RAIL INTAKE MANIFOLD / FUEL RAIL INTAKE MANIFOLD / FUEL RAIL INTAKE MANIFOLD / FUEL RAIL INTAKE MANIFOLD / FUEL RAIL INTAKE MANIFOLD / FUEL RAIL
FUEL INJECTOR – 1A	FT3 / 6-WAY SUMITOMO DL090 / NATURAL	FUEL TANK EVAPORATIVE FLANGE
FUEL INJECTOR – 1B	BT10 / 10-WAY U.T.A. FUSEBOX / NATURAL	
FUEL INJECTOR – 2A	BT11 / 10-WAY U.T.A. FUSEBOX / BLACK	
FUEL INJECTOR – 2B	BT12 / 10-WAY U.T.A. FUSEBOX / GREEN	
FUEL INJECTOR – 3A	BT13 / 10-WAY U.T.A. FUSEBOX / BLUE	
FUEL INJECTOR – 3B	BT64 / EYELET	
FUEL INJECTOR – 4A	PI51 / 4-WAY YAZAKI / BLACK	ENGINE COMPARTMENT / CAMSHAFT COVER
FUEL INJECTOR – 4B	PI55 / 4-WAY YAZAKI / BL ACK	ENGINE COMPARTMENT / CAMSHAFT COVER
FUEL PUMPS	PI52 / 4-WAY YAZAKI / BLACK	ENGINE COMPARTMENT / CAMSHAFT COVER
FUSE BOX – TRUNK	PI56 / 4-WAY YAZAKI / BLACK PI53 / 4-WAY YAZAKI / BLACK PI57 / 4-WAY YAZAKI / BLACK PI54 / 4-WAY YAZAKI / BLACK PI58 / 4-WAY YAZAKI / BLACK	ENGINE COMPARTMENT / CAMSHAFT COVER ENGINE COMPARTMENT / CAMSHAFT COVER ENGINE COMPARTMENT / CAMSHAFT COVER ENGINE COMPARTMENT / CAMSHAFT COVER ENGINE COMPARTMENT / CAMSHAFT COVER
IGNITION COIL – 1A	EM75 / 2-WAY AUGAT 1.6 / BLACK	ENGINE COMPARTMENT / BELOW AIR CLEANER
IGNITION COIL – 1B	LF9 / 8-WAY TRW / BLACK	ADJACENT TO LEFT HAND HORN
IGNITION COIL – 2A	LF13 / 2-WAY REINSHAGEN METRI 630 / BLACK	ENGINE COMPARTMENT / FRONT
IGNITION COIL – 2B	LF12 / 2-WAY REINSHAGEN METRI 630 / BLACK	ENGINE COMPARTMENT / FRONT
IGNITION COIL – 3A	LF57 / 6-WAY ECONOSEAL III LC / BLACK	ENGINE COMPARTMENT / REARWARD OF RADIATOR
IGNITION COIL – 3B		
IGNITION COIL – 4A		
IGNITION COIL – 4B		
INTERCOOLER PUMP		
RADIATOR FAN CONTROL RELAY MODULE		
RADIATOR FAN – LH		
RADIATOR FAN – RH		
REFRIGERANT 4-WAY PRESSURE SWITCH		

### RELAYS

Relay	Color / Stripe	Connector / Color	Location / Access
AIR CONDITIONING COMPRESSOR CLUTCH RELAY	BROWN	EM17	LH ENCLOSURE RELAYS
FUEL INJECTION RELAY	BROWN	EM5 / BROWN	CONTROL MODULE ENCLOSURE RELAYS
FUEL PUMP 1 RELAY (#4)	BROWN	BUS	TRUNK FUSE BOX
FUEL PUMP 2 RELAY	BROWN	BT51 / BROWN	TRUNK RELAYS
IGNITION COIL RELAY	BROWN	EM26 / BROWN	CONTROL MODULE ENCLOSURE RELAYS
INTERCOOLER PUMP RELAY	BROWN	EM31 / BROWN	LHD: CONTROL MODULE ENCLOSURE RELAYS RHD: RH ENCLOSURE RELAYS

### HARNESSTO-HARNESSTO CONNECTORS

Connector	Type / Color	Location / Access
AC12	20-WAY MULTILOCK 070 / WHITE	FASCIA TOP CONNECTOR MOUNTING BRACKET / RIGHT HAND SIDE
AC13	20-WAY MULTILOCK 070 / YELLOW	FASCIA BOTTOM CONNECTOR MOUNTING BRACKET / RIGHT HAND SIDE
BT2	20-WAY MULTILOCK 070 / WHITE	TRUNK / ABOVE RIGHT HAND REAR WHEEL ARCH
EM1	20-WAY MULTILOCK 070 / WHITE	ENGINE COMPARTMENT / ADJACENT TO RIGHT HAND ENCLOSURE
EM2	18-WAY MULTILOCK 070 / YELLOW	ENGINE COMPARTMENT / ADJACENT TO RIGHT HAND ENCLOSURE
EM3	14-WAY MULTILOCK 070 / GREY	ENGINE COMPARTMENT / ADJACENT TO RIGHT HAND ENCLOSURE
FT1	10-WAY MULTILOCK 070 / WHITE	FUEL TANK / REAR
LF3	13-WAY ECONOSEAL III LC / WHITE	LHD: ENGINE COMPARTMENT / ADJACENT TO BRAKE SERVO RHD: ENGINE COMPARTMENT / CONTROL MODULE ENCLOSURE
LF40	13-WAY ECONOSEAL III LC / BLACK	LHD: ENGINE COMPARTMENT / FORWARD OF BRAKE FLUID RESERVOIR RHD: ENGINE COMPARTMENT / BELOW CONTROL MODULE ENCLOSURE
PI1	57-WAY SUMITOMO TS090 / BLACK	ENGINE COMPARTMENT / BRACKET ON TOP OF TRANSMISSION
PI2	13-WAY ECONOSEAL III LC / BLACK	ENGINE COMPARTMENT / BRACKET ON TOP OF TRANSMISSION
RH1	20-WAY MULTILOCK 070 / GREY	BEHIND GLOVE BOX
RH2	20-WAY MULTILOCK 070 / WHITE	REAR OF CENTER CONSOLE ASSEMBLY
SC3	12-WAY MULTILOCK 070 / GREY	RIGHT HAND SIDE OF STEERING COLUMN
SW1	12-WAY MULTILOCK 040 / BLACK	INSIDE STEERING COLUMN COWL
SW2	6-WAY JST / WHITE	CENTER OF STEERING WHEEL

### GROUNDSTO

Ground	Location / Type
BT2AL	EYELET (PAIR) – LEFT HAND LEG / TRUNK, RIGHT REAR
EM1AL	EYELET (PAIR) – LEFT HAND LEG / ENGINE COMPARTMENT, RIGHT HAND ENCLOSURE
EM1AR	EYELET (PAIR) – RIGHT HAND LEG / ENGINE COMPARTMENT, RIGHT HAND ENCLOSURE
EM2AL	EYELET (PAIR) – LEFT HAND LEG / ENGINE COMPARTMENT, LEFT HAND ENCLOSURE
EM2AR	EYELET (PAIR) – RIGHT HAND LEG / ENGINE COMPARTMENT, LEFT HAND ENCLOSURE
FC3BL	EYELET (PAIR) – LEFT HAND LEG / TRANSMISSION TUNNEL, LEFT HAND SIDE
LF2AL	EYELET (PAIR) – LEFT HAND LEG / ENGINE COMPARTMENT, FORWARD OF LEFT HAND HOOD CATCH
LF2AR	EYELET (PAIR) – RIGHT HAND LEG / ENGINE COMPARTMENT, FORWARD OF LEFT HAND HOOD CATCH
LF2BL	EYELET (PAIR) – LEFT HAND LEG / ENGINE COMPARTMENT, FORWARD OF LEFT HAND HOOD CATCH

The following abbreviations are used to represent values for Control Module Pin-Out data

I	Input	SG	Sensor Ground	S	SCP Network	V	Voltage (DC)
O	Output	A	ACP Network	D	Serial and Encoded Data	Hz	Frequency
SS	Sensor Supply V	C	CAN (Network)	B+	Battery Voltage	kHz	Frequency x 1000

**CAUTION:** The information on this data page is furnished to aid the user in understanding circuit operation. THIS INFORMATION SHOULD BE USED FOR REFERENCE ONLY.

**NOTE:** The values listed are approximately those that can be expected at the control module connector pins with all circuit connections made and all components connected and fitted. “Active” means a load is applied or a switch is ON; “Inactive” means a load is not applied or a switch is OFF.

FOR CONTROL MODULE PIN OUT INFORMATION, UNFOLD PAGE TO LEFT.

Refer to the front of this book for detailed information and illustrations regarding the location and identification of harnesses, relays, grounds, control modules and control module pins.



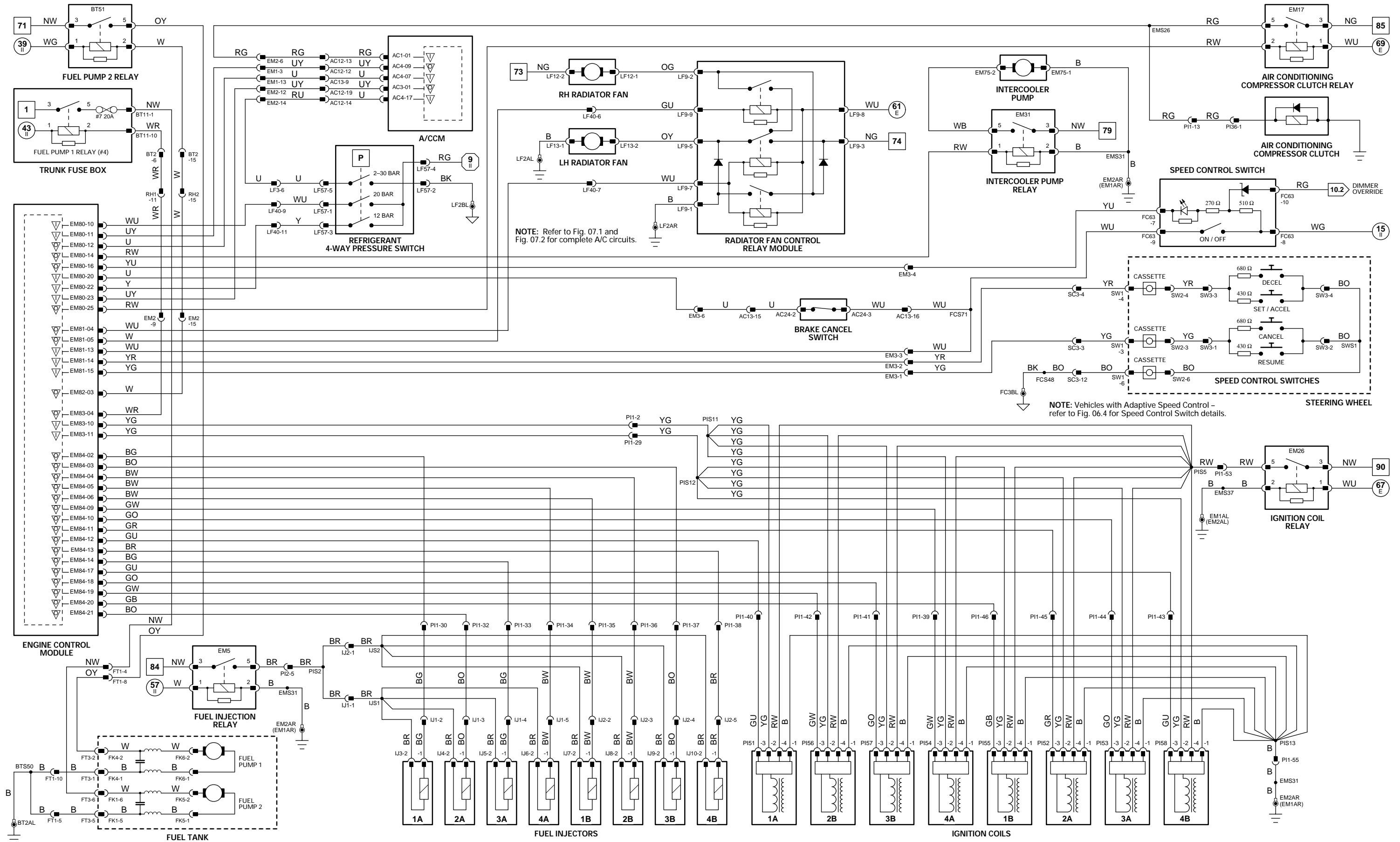

NOTE: Refer to Fig. 07.1 and Fig. 07.2 for complete A/C circuits.

NOTE: Vehicles with Adaptive Speed Control - refer to Fig. 06.4 for Speed Control Switch details.

NOTE: ECM power supplies and grounds shown on Fig. 04.3.

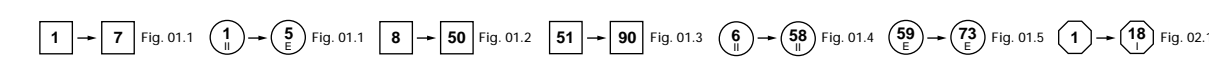

VARIANT: AJ27 SC Vehicles  
 VIN RANGE: A11051 →  
 DATE OF ISSUE: September 2000

## CONTROL MODULE PIN OUT INFORMATION

### GEAR SELECTOR ILLUMINATION MODULE

Pin	Description	Active	Inactive
I FC88-1	IGNITION SWITCHED POWER SUPPLY	B+	GROUND
C FC88-3	CAN NETWORK	15 – 1500 Hz @ 2.5 V	
C FC88-4	CAN NETWORK	15 – 1500 Hz @ 2.5 V	
I FC88-6	GROUND	GROUND	GROUND
C FC88-8	CAN NETWORK	15 – 1500 Hz @ 2.5 V	
C FC88-9	CAN NETWORK	15 – 1500 Hz @ 2.5 V	

### TRANSMISSION CONTROL MODULE: AJ27 N/A

Pin	Description	Active	Inactive
O EM7-1	PRESSURE REGULATOR #2	GROUND (MAXIMUM PRESSURE)	B+ (NO PRESSURE)
O EM7-2	SPORT MODE SWITCH STATUS LED	GROUND = LED ON	B+
O EM7-4	PRESSURE REGULATOR #4	GROUND (MAXIMUM PRESSURE)	B+ (NO PRESSURE)
O EM7-5	PRESSURE REGULATOR #1	GROUND (MAXIMUM PRESSURE)	B+ (NO PRESSURE)
I EM7-6	GROUND	GROUND	GROUND
I EM7-8	ROTARY SWITCH 'L2' CONTACTS	B+	GROUND
I EM7-9	ROTARY SWITCH 'L4' CONTACTS	B+	GROUND
I EM7-12	SPORT MODE SWITCH STRATEGY SELECT	GROUND = SPORT	9 V = NORMAL
I EM7-13	D – 4 SWITCH	GROUND	B+
SG EM7-14	TURBINE SPEED SENSOR SIGNAL GROUND	GROUND	GROUND
SG EM7-15	OUTPUT SPEED SENSOR SHIELD	GROUND	GROUND
SG EM7-16	OUTPUT SPEED SENSOR SIGNAL GROUND	GROUND	GROUND
SG EM7-21	FLUID TEMPERATURE SENSOR SIGNAL GROUND	1.31 V	
I EM7-22	FLUID TEMPERATURE SENSOR SIGNAL	1.15 V @ 90°C	
SG EM7-23	TURBINE SPEED SENSOR SHIELD	GROUND	GROUND
I EM7-26	BATTERY POWER SUPPLY	B+	B+
SG EM7-28	ROTARY / D-4 / KICK DOWN SWITCHES COMMON GROUND	GROUND	GROUND
O EM7-29	PRESSURE REGULATOR #3	GROUND (MAXIMUM PRESSURE)	B+ (NO PRESSURE)
O EM7-30	SOLENOID VALVE #1	GROUND	B+
O EM7-32	SOLENOID VALVE #3	GROUND	B+
O EM7-33	SOLENOID VALVE #2	GROUND	B+
I EM7-34	GROUND	GROUND	GROUND
I EM7-36	ROTARY SWITCH 'L1' CONTACTS	B+	GROUND
I EM7-37	ROTARY SWITCH 'L3' CONTACTS	B+	GROUND
I EM7-42	TURBINE SPEED SENSOR SIGNAL	1.51 V @ 10 MPH (16 KM/H) = 250 Hz, 20 MPH (32 KM/H) = 500 Hz	
I EM7-44	OUTPUT SPEED SENSOR SIGNAL	1.51 V @ 10 MPH (16 KM/H) = 223 Hz, 20 MPH (32 KM/H) = 446 Hz	
I EM7-45	SPORT MODE SWITCH STRATEGY SELECT	10 v = SPORT	GROUND = NORMAL
O EM7-51	PRESSURE REGULATOR #5	GROUND (MAXIMUM PRESSURE)	B+ (NO PRESSURE)
O EM7-52	PRESSURE REGULATORS / SOLENOID VALVES POWER SUPPLY	B+	B+
O EM7-53	PRESSURE REGULATORS / SOLENOID VALVES POWER SUPPLY	B+	B+
I EM7-54	IGNITION SWITCHED POWER SUPPLY	B+	GROUND
I EM7-55	IGNITION SWITCHED POWER SUPPLY	B+	GROUND
C EM7-82	CAN NETWORK	15 – 1500 Hz	
C EM7-83	CAN NETWORK	15 – 1500 Hz	
C EM7-85	CAN NETWORK	15 – 1500 Hz	
C EM7-86	CAN NETWORK	15 – 1500 Hz	

**NOTE:** Refer to the Appendix at the rear of this book for CAN and SCP Network Messages.

## Fig. 05.1

### COMPONENTS

Component	Connector / Type / Color	Location / Access
D – 4 SWITCH	FC83 / 3-WAY MULTILOCK 070 / YELLOW	GEAR SELECTOR ASSEMBLY, REAR
GEAR SELECTOR ILLUMINATION MODULE	FC88 / 10-WAY MULTILOCK 070 / WHITE	FRONT OF GEAR SELECTOR ASSEMBLY
MODE SWITCH (TRANSMISSION)	FC35 / 10-WAY AMP MQL / BLACK	REARWARD OF GEAR SELECTOR
TRANSMISSION CONTROL MODULE: AJ27 N/A	EM7 / 88-WAY BOSCH / BLACK	ENGINE COMPARTMENT / CONTROL MODULE ENCLOSURE
TRANSMISSION ELECTRICAL CONNECTOR: AJ27 N/A	EM46 / 16-WAY KOSTAL / BLACK	TRANSMISSION / LEFT HAND SIDE
TRANSMISSION ROTARY SWITCH	EM47 / 10-WAY METRI-PACK 150 / BLACK	TRANSMISSION / RIGHT HAND SIDE

### HARNESS-TO-HARNESS CONNECTORS

Connector	Type / Color	Location / Access
AC12	20-WAY MULTILOCK 070 / WHITE	FASCIA TOP CONNECTOR MOUNTING BRACKET / RIGHT HAND SIDE
EM1	20-WAY MULTILOCK 070 / WHITE	ENGINE COMPARTMENT / ADJACENT TO RIGHT HAND ENCLOSURE
EM3	14-WAY MULTILOCK 070 / GREY	ENGINE COMPARTMENT / ADJACENT TO RIGHT HAND ENCLOSURE

### GROUNDS

Ground	Location / Type
EM1AL	EYELET (PAIR) – LEFT HAND LEG / ENGINE COMPARTMENT, RIGHT HAND ENCLOSURE
EM1BR	EYELET (PAIR) – RIGHT HAND LEG / ENGINE COMPARTMENT, RIGHT HAND ENCLOSURE
EM1BS	EYELET (SINGLE) / ENGINE COMPARTMENT, RIGHT HAND ENCLOSURE
EM2AL	EYELET (PAIR) – LEFT HAND LEG / ENGINE COMPARTMENT, LEFT HAND ENCLOSURE
EM2BR	EYELET (PAIR) – RIGHT HAND LEG / ENGINE COMPARTMENT, LEFT HAND ENCLOSURE
EM2BS	EYELET (SINGLE) / ENGINE COMPARTMENT, LEFT HAND ENCLOSURE
FC3BR	EYELET (PAIR) – RIGHT HAND LEG / TRANSMISSION TUNNEL, LEFT HAND SIDE

**FOR CONTROL MODULE PIN OUT INFORMATION, UNFOLD PAGE TO LEFT.**

The following abbreviations are used to represent values for Control Module Pin-Out data

<b>I</b>	<b>Input</b>	<b>SG</b>	<b>Sensor Ground</b>	<b>S</b>	<b>SCP Network</b>	<b>V</b>	<b>Voltage (DC)</b>
<b>O</b>	<b>Output</b>	<b>A</b>	<b>ACP Network</b>	<b>D</b>	<b>Serial and Encoded Data</b>	<b>Hz</b>	<b>Frequency</b>
<b>SS</b>	<b>Sensor Supply V</b>	<b>C</b>	<b>CAN (Network)</b>	<b>B+</b>	<b>Battery Voltage</b>	<b>kHz</b>	<b>Frequency x 1000</b>

**CAUTION:** The information on this data page is furnished to aid the user in understanding circuit operation. THIS INFORMATION SHOULD BE USED FOR REFERENCE ONLY.

**NOTE:** The values listed are approximately those that can be expected at the control module connector pins with all circuit connections made and all components connected and fitted. “Active” means a load is applied or a switch is ON; “Inactive” means a load is not applied or a switch is OFF.

Refer to the front of this book for detailed information and illustrations regarding the location and identification of harnesses, relays, grounds, control modules and control module pins.



\* NOTE: Transmission internal wiring revised at Transmission Serial Number 191393. This revision was made after the original Electrical Guide was published; original printed copies do not include this revision.

NOTE: Gear Selector Illumination Module – CAN 'Listen only' node for gear selector position indicators.

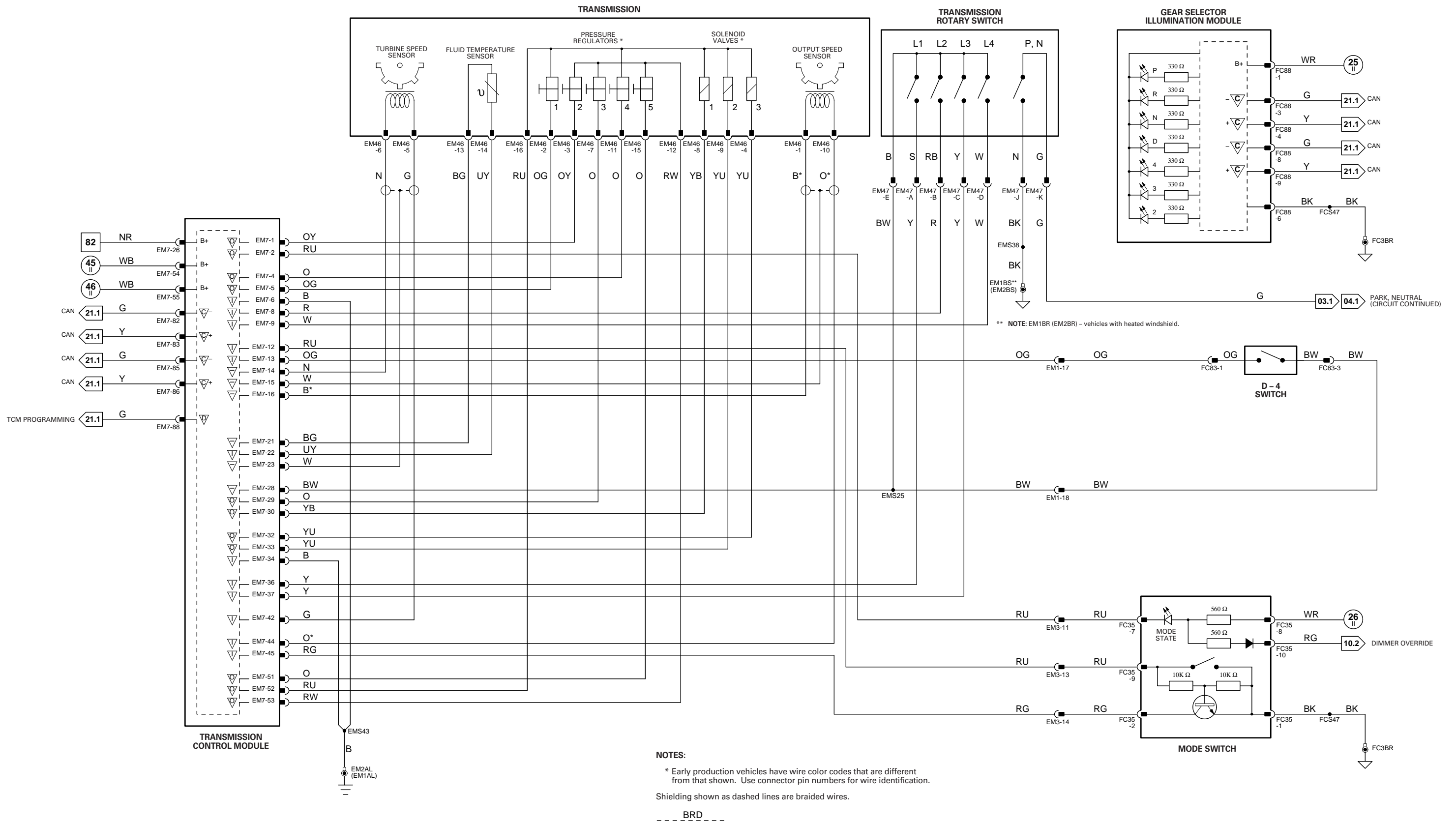

**NOTES:**

- \* Early production vehicles have wire color codes that are different from that shown. Use connector pin numbers for wire identification.
- Shielding shown as dashed lines are braided wires.

--- BRD ---

**CONTROL MODULE PIN OUT INFORMATION**

**GEAR SELECTOR ILLUMINATION MODULE**

Pin	Description	Active	Inactive
I FC88-1	IGNITION SWITCHED POWER SUPPLY	B+	GROUND
C FC88-3	CAN NETWORK	15 – 1500 Hz @ 2.5 V	
C FC88-4	CAN NETWORK	15 – 1500 Hz @ 2.5 V	
I FC88-6	GROUND	GROUND	GROUND
C FC88-8	CAN NETWORK	15 – 1500 Hz @ 2.5 V	
C FC88-9	CAN NETWORK	15 – 1500 Hz @ 2.5 V	

**TRANSMISSION CONTROL MODULE: AJ27 SC**

Pin	Description	Active	Inactive
C EM72-L	CAN NETWORK	5 – 1500 Hz	
C EM72-H	CAN NETWORK	5 – 1500 Hz	
I EM72-12	n2 SPEED SENSOR SIGNAL	6V = 900 Hz @ 10 MPH (16 KPH); 1800 HZ @ 20 MPH (32 KH) ('2' SELECTED – '1' ENGAGED)	
SS EM72-13	SPEED SENSOR COMMON VOLTAGE SUPPLY	5V	
O EM72-14	'1-2 / 4-5' SOLENOID ACTIVATE	GROUND	B+
O EM72-15	'3-4' SOLENOID ACTIVATE	GROUND	B+
O EM72-16	'2-3' SOLENOID ACTIVATE	GROUND	B+
O EM72-17	TCC SOLENOID ACTIVATE	GROUND = LOCKED	B+ = UNLOCKED
SG EM72-33	SPEED SENSOR / FLUID TEMP. SENSOR COMMON GROUND	GROUND	GROUND
I EM72-34	FLUID TEMP. SENSOR SIGNAL	1.75 V @ 90° C = R, D, 4, 3, 2	5 V = P, N
I EM72-35	n3 SPEED SENSOR SIGNAL	6 V = 85 Hz @ 10 MPH (16 KPH); 170 Hz @ 20 MPH (32 KPH) ('2' SELECTED – '2' ENGAGED)	
O EM72-36	MODULATION PRESSURE REGULATOR ACTIVATE	GROUND ( 42% PWM @ IDLE)	B+
O EM72-37	SHIFT PRESSURE REGULATOR ACTIVATE	GROUND ( 39% PWM @ IDLE)	B+
O EM72-38	SOLENOID VALVE / PRESSURE REGULATOR COMMON VOLTAGE SUPPLY	B+	GROUND
I EM73-2	KICKDOWN SWITCH	GROUND (= WOT)	B+ (< WOT)
I EM73-3	SPORT MODE SWITCH	0 V = SPORT; 0 V = NORMAL	
I EM73-25	DUAL LINEAR SWITCH VOLTAGE ENCODED GEAR RECOGNITION	GROUND = R, D, 4, 3	B+ = P, N, 2
I EM73-26	DUAL LINEAR SWITCH VOLTAGE ENCODED GEAR RECOGNITION	GROUND = N, D, 4, 2	B+ = P, R, 3
I EM73-27	DUAL LINEAR SWITCH VOLTAGE ENCODED GEAR RECOGNITION	GROUND = N, 4, 3, 2      8 V = R, D	B+ = P
I EM73-28	DUAL LINEAR SWITCH VOLTAGE ENCODED GEAR RECOGNITION	GROUND = P, D, 3, 2	B+ = R, N, 4
I EM73-29	IGNITION SUPPLIED VOLTAGE	B+	GROUND
I EM73-30	TCM / DUAL LINEAR SWITCH COMMON GROUND SUPPLY	GROUND	GROUND

**NOTE:** Refer to the Appendix at the rear of this book for CAN and SCP Network Messages.

**Fig. 05.2**

**COMPONENTS**

Component	Connector / Type / Color	Location / Access
DUAL LINEAR SWITCH GEAR SELECTOR ILLUMINATION MODULE KICKDOWN SWITCH	FC100 / 12-WAY / MULTILOCK 070 / GREY FC88 / 10-WAY MULTILOCK 070 / WHITE AC27 / 1-WAY LUCAR RIGHT ANGLE / CLEAR AC28 / 1-WAY LUCAR RIGHT ANGLE / CLEAR	LEFT HAND SIDE OF GEAR SELECTOR / CENTER CONSOLE FRONT OF GEAR SELECTOR ASSEMBLY UNDER ACCELERATOR PEDAL
MODE SWITCH (TRANSMISSION) TRANSMISSION CONTROL MODULE: AJ27 SC	FC35 / 10-WAY AMP MQL / BLACK EM72 / 14-WAY AMP JUNIOR POWER TIMER / BLACK EM73 / 18-WAY AMP JUNIOR POWER TIMER / BLACK	REARWARD OF GEAR SELECTOR ENGINE COMPARTMENT / CONTROL MODULE ENCLOSURE
TRANSMISSION ELECTRICAL CONNECTOR: AJ27 SC	GB1 / 13-WAY KOSTAL 1.5 / BLACK	TRANSMISSION

**HARNESSTO-HARNESSTO CONNECTORS**

Connector	Type / Color	Location / Access
AC12	20-WAY MULTILOCK 070 / WHITE	FASCIA TOP CONNECTOR MOUNTING BRACKET / RIGHT HAND SIDE
EM1	20-WAY MULTILOCK 070 / WHITE	ENGINE COMPARTMENT / ADJACENT TO RIGHT HAND ENCLOSURE
EM2	18-WAY MULTILOCK 070 / YELLOW	ENGINE COMPARTMENT / ADJACENT TO RIGHT HAND ENCLOSURE
EM3	14-WAY MULTILOCK 070 / GREY	ENGINE COMPARTMENT / ADJACENT TO RIGHT HAND ENCLOSURE
GB2	12-WAY AUGAT 1.6 / BLACK	ENGINE COMPARTMENT / BRACKET ON TOP OF TRANSMISSION

**GROUNDS**

Ground	Location / Type
EM1AL	EYELET (PAIR) – LEFT HAND LEG / ENGINE COMPARTMENT, RIGHT HAND ENCLOSURE
EM2AL	EYELET (PAIR) – LEFT HAND LEG / ENGINE COMPARTMENT, LEFT HAND ENCLOSURE
FC3BL	EYELET (PAIR) – LEFT HAND LEG / TRANSMISSION TUNNEL, LEFT HAND SIDE
FC3BR	EYELET (PAIR) – RIGHT HAND LEG / TRANSMISSION TUNNEL, LEFT HAND SIDE

**FOR CONTROL MODULE PIN OUT INFORMATION, UNFOLD PAGE TO LEFT.**

The following abbreviations are used to represent values for Control Module Pin-Out data

I	Input	SG	Sensor Ground	S	SCP Network	V	Voltage (DC)
O	Output	A	ACP Network	D	Serial and Encoded Data	Hz	Frequency
SS	Sensor Supply V	C	CAN (Network)	B+	Battery Voltage	kHz	Frequency x 1000

**CAUTION:** The information on this data page is furnished to aid the user in understanding circuit operation. THIS INFORMATION SHOULD BE USED FOR REFERENCE ONLY.

**NOTE:** The values listed are approximately those that can be expected at the control module connector pins with all circuit connections made and all components connected and fitted. "Active" means a load is applied or a switch is ON; "Inactive" means a load is not applied or a switch is OFF.

Refer to the front of this book for detailed information and illustrations regarding the location and identification of harnesses, relays, grounds, control modules and control module pins.

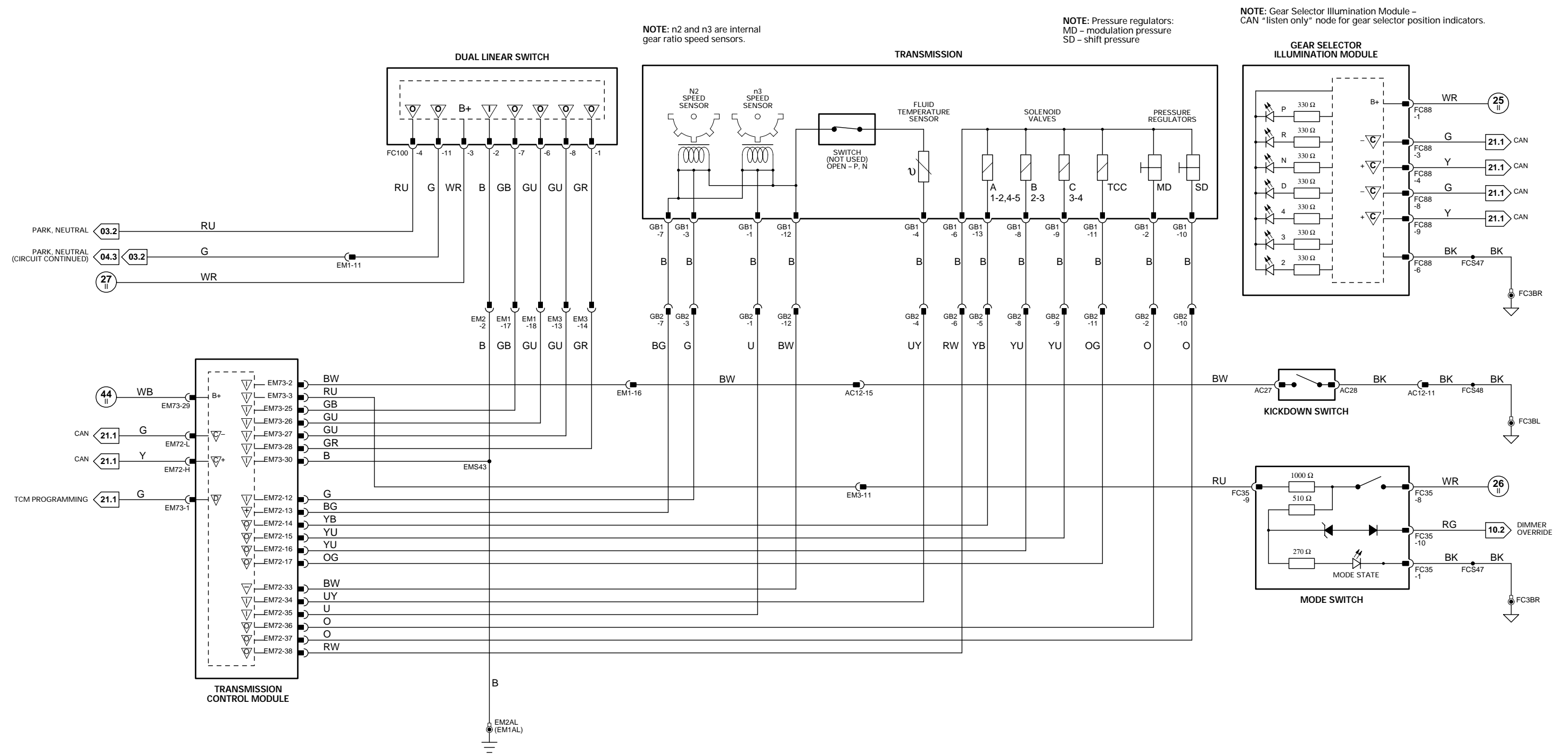

**CONTROL MODULE PIN OUT INFORMATION**

**Fig. 05.3**

**BODY PROCESSOR MODULE**

Pin	Description	Active	Inactive
I FC14-15	IGNITION SWITCHED GROUND SUPPLY	GROUND	GROUND
I FC14-32	IGNITION SWITCHED GROUND SUPPLY	GROUND	GROUND
O FC14-48	GEARSHIFT INTERLOCK SOLENOID SUPPLY	B+ (GEARSHIFT FREE)	GROUND (GEARSHIFT LOCKED)
O FC14-51	KEY LOCK SOLENOID SUPPLY	B+ (KEY CAPTIVE)	GROUND (KEY RELEASED)
I FC14-58	NOT-IN-PARK	GROUND (R,N,D,4,3,2)	B+ (PARK)
I FC14-80	BATTERY POWER SUPPLY (LOGIC)	B+	B+
S FC14-84	SCP NETWORK	2 - 1600 Hz	
S FC14-85	SCP NETWORK	2 - 1600 Hz	
I FC14-104	LIGHTING / MOTORS BATTERY POWER SUPPLY	B+	

**ENGINE CONTROL MODULE**

Pin	Description	Active	Inactive
I EM82-08	BRAKE SWITCH	GROUND	
C EM83-16	CAN NETWORK	15 - 1500 Hz	
C EM83-25	CAN NETWORK	15 - 1500 Hz	

**GEAR SELECTOR ILLUMINATION MODULE**

Pin	Description	Active	Inactive
C FC88-4	CAN NETWORK	15 - 1500 Hz @ 2.5 V	
C FC88-3	CAN NETWORK	15 - 1500 Hz @ 2.5 V	
C FC88-8	CAN NETWORK	15 - 1500 Hz @ 2.5 V	
C FC88-9	CAN NETWORK	15 - 1500 Hz @ 2.5 V	

**MAJOR INSTRUMENT PACK**

Pin	Description	Active	Inactive
C FC25-11	CAN NETWORK	15 - 1500 Hz	
S FC25-13	SCP NETWORK	2 - 1600 Hz	
S FC25-14	SCP NETWORK	2 - 1600 Hz	
C FC25-23	CAN NETWORK	15 - 1500 Hz	

**NOTE:** Refer to the Appendix at the rear of this book for CAN and SCP Network Messages.

**COMPONENTS**

Component	Connector / Type / Color	Location / Access
BODY PROCESSOR MODULE	FC14 / 104-WAY AMP EEEC / GREY	PASSENGER SIDE FASCIA / AIRBAG BRACKET
BRAKE SWITCH	AC24 / 4-WAY MULTILOCK 070 / WHITE	TOP OF BRAKE PEDAL
ENGINE CONTROL MODULE	EM80 / 31-WAY AMP 403 / NATURAL EM81 / 24-WAY AMP 403 / NATURAL EM82 / 17-WAY AMP 403 / NATURAL EM83 / 28-WAY AMP 403 / NATURAL EM84 / 22-WAY AMP 403 / NATURAL EM85 / 12-WAY MULTILOCK 070 / WHITE	ENGINE COMPARTMENT / CONTROL MODULE ENCLOSURE
GEAR SELECTOR ILLUMINATION MODULE	FC88 / 10-WAY MULTILOCK 070 / WHITE	FRONT OF GEAR SELECTOR ASSEMBLY
GEARSHIFT INTERLOCK SOLENOID	FC86 / 2-WAY MULTILOCK 070 / WHITE	GEAR SELECTOR ASSEMBLY
KEYLOCK SOLENOID (COLUMN SWITCHGEAR)	SC1 / 12-WAY MULTILOCK 070 / WHITE	STEERING COLUMN
MAJOR INSTRUMENT PACK	FC25 / 26-WAY AMP MICRO QUAD LOCK / BLACK FC26 / 26-WAY AMP MICRO QUAD LOCK / YELLOW FC87 / 3-WAY MULTILOCK 070 / WHITE	FASCIA
NOT-IN-PARK MICROSWITCH		GEAR SELECTOR ASSEMBLY

**HARNESS-TO-HARNESS CONNECTORS**

Connector	Type / Color	Location / Access
AC13	20-WAY MULTILOCK 070 / YELLOW	FASCIA BOTTOM CONNECTOR MOUNTING BRACKET / RIGHT HAND SIDE
EM1	20-WAY MULTILOCK 070 / WHITE	ENGINE COMPARTMENT / ADJACENT TO RIGHT HAND ENCLOSURE

**GROUNDS**

Ground	Location / Type
FC2BR	EYELET (PAIR) - RIGHT HAND LEG / RIGHT HAND 'A' POST
FC3BR	EYELET (PAIR) - RIGHT HAND LEG / TRANSMISSION TUNNEL, LEFT HAND SIDE
FC4BR	EYELET (PAIR) - RIGHT HAND LEG / LEFT HAND 'A' POST

**FOR CONTROL MODULE PIN OUT INFORMATION, UNFOLD PAGE TO LEFT.**

The following abbreviations are used to represent values for Control Module Pin-Out data

I	Input	SG	Sensor Ground	S	SCP Network	V	Voltage (DC)
O	Output	A	ACP Network	D	Serial and Encoded Data	Hz	Frequency
SS	Sensor Supply V	C	CAN (Network)	B+	Battery Voltage	kHz	Frequency x 1000

**CAUTION:** The information on this data page is furnished to aid the user in understanding circuit operation. THIS INFORMATION SHOULD BE USED FOR REFERENCE ONLY.

**NOTE:** The values listed are approximately those that can be expected at the control module connector pins with all circuit connections made and all components connected and fitted. "Active" means a load is applied or a switch is ON; "Inactive" means a load is not applied or a switch is OFF.

Refer to the front of this book for detailed information and illustrations regarding the location and identification of harnesses, relays, grounds, control modules and control module pins.

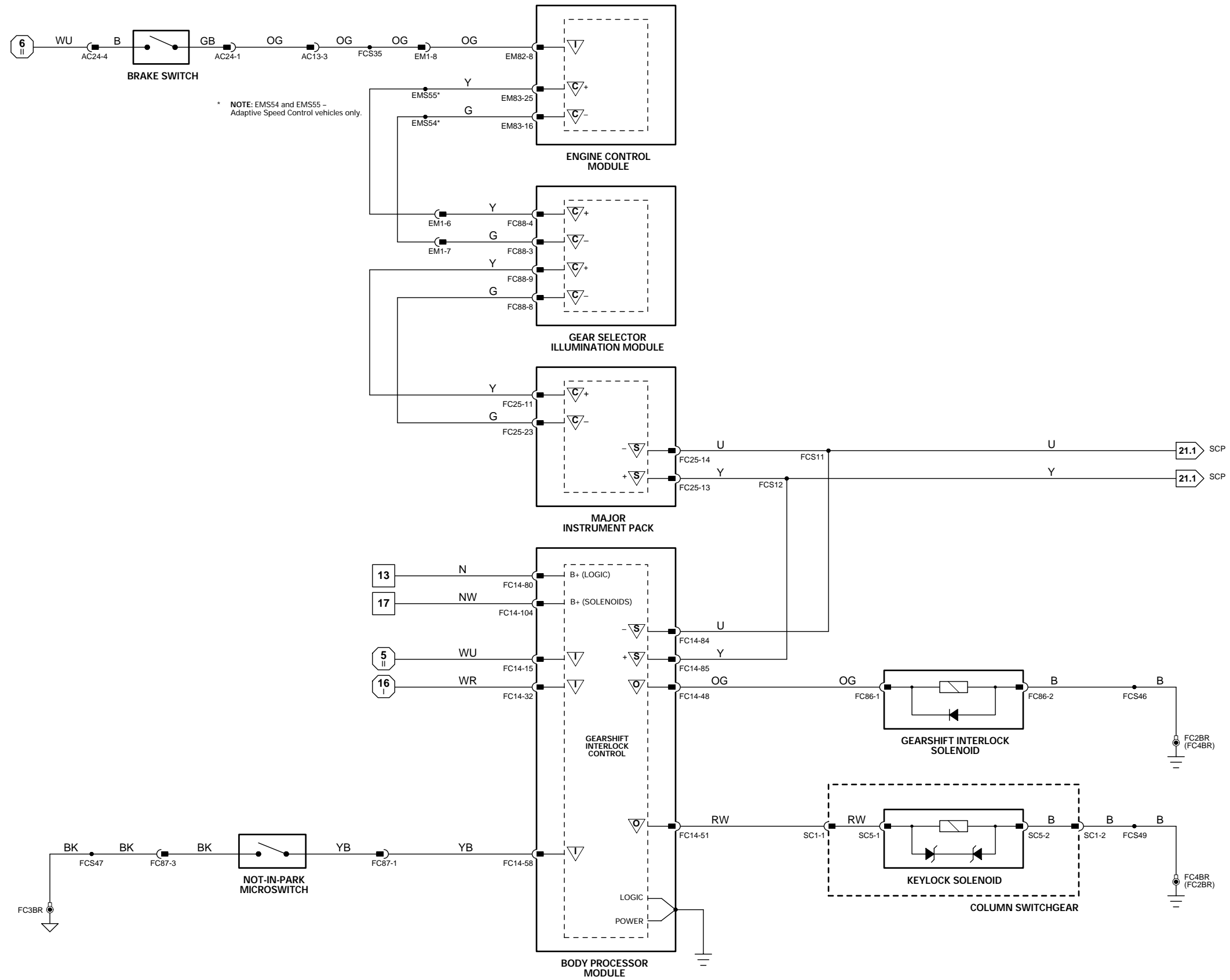

\* NOTE: EMS54 and EMS55 - Adaptive Speed Control vehicles only.

**CONTROL MODULE PIN OUT INFORMATION**

**Fig. 06.1**

**ABS / TRACTION CONTROL CONTROL MODULE**

Pin	Description	Active	Inactive
O LF37-1	BRAKE FLUID RESERVOIR LEVEL SWITCH REFERENCE	B+	B+
I LF37-2	BRAKE SWITCH	GROUND	B+
I LF37-3	RH FRONT WHEEL SPEED SENSOR SIGNAL	2.5 V @ 10 MPH (16 KM/H) = 100 Hz; 20 MPH (32 KM/H) = 200 Hz	
SG LF37-4	RH FRONT WHEEL SPEED SENSOR SIGNAL GROUND	2.5 V @ REST	
C LF37-5	CAN NETWORK	15 – 1500 Hz	
SG LF37-6	RH REAR WHEEL SPEED SENSOR SIGNAL GROUND	2.5 V @ REST	
I LF37-7	RH REAR WHEEL SPEED SENSOR SIGNAL	2.5 V @ 10 MPH (16 KM/H) = 100 Hz; 20 MPH (32 KM/H) = 200 Hz	
I LF37-8	GROUND	GROUND	GROUND
I LF37-9	BATTERY POWER SUPPLY	B+	B+
LF37-10	NOT USED		
LF37-11	NOT USED		
I LF37-13	BRAKE FLUID RESERVOIR LEVEL SWITCH	GROUND	B+
I LF37-14	STABILITY / TRACTION CONTROL SWITCH	GROUND (MOMENTARY)	B+
C LF37-15	CAN NETWORK	15 – 1500 Hz	
O LF37-16	STABILITY / TRACTION CONTROL SWITCH STATE LED	GROUND	B+
I LF37-17	LH FRONT WHEEL SPEED SENSOR SIGNAL	2.5 V @ 10 MPH (16 KM/H) = 100 Hz; 20 MPH (32 KM/H) = 200 Hz	
SG LF37-18	LH FRONT WHEEL SPEED SENSOR SIGNAL GROUND	2.5 V @ REST	
LF37-19	NOT USED		
I LF37-20	IGNITION SWITCHED SUPPLY	B+	GROUND
I LF37-21	LH REAR WHEEL SPEED SENSOR SIGNAL	2.5 V @ 10 MPH (16 KM/H) = 100 Hz; 20 MPH (32 KM/H) = 200 Hz	
SG LF37-22	LH REAR WHEEL SPEED SENSOR SIGNAL GROUND	2.5 V @ REST	
I LF37-24	GROUND	GROUND	GROUND
I LF37-25	BATTERY POWER SUPPLY	B+	B+

**NOTE:** Refer to the Appendix at the rear of this book for CAN and SCP Network Messages.

**COMPONENTS**

Component	Connector / Type / Color	Location / Access
ABS / TRACTION CONTROL CONTROL MODULE	LF37 / 25-WAY AMP HYBRID / BLACK	ENGINE COMPARTMENT / FRONT LEFT
BRAKE FLUID RESERVOIR	EM37 / 2-WAY AMP JUNIOR POWER TIMER / BLACK	ENGINE COMPARTMENT / BRAKE BOOSTER ENCLOSURE
BRAKE SWITCH	AC24 / 4-WAY MULTILOCK 070 / WHITE	TOP OF BRAKE PEDAL
STABILITY / TRACTION CONTROL SWITCH (CENTER CONSOLE SWITCH PACK)	FC55 / 20-WAY FORD IDC / BLACK	CENTER CONSOLE SWITCH PACK
WHEEL SPEED SENSOR – LH FRONT	FL1 / 2-WAY REINSHAGEN METRI 630 / BLACK	WHEEL HUB
WHEEL SPEED SENSOR – LH REAR	RL1 / 2-WAY REINSHAGEN METRI 630 / BLACK	WHEEL HUB
WHEEL SPEED SENSOR – RH FRONT	FR1 / 2-WAY REINSHAGEN METRI 630 / BLACK	WHEEL HUB
WHEEL SPEED SENSOR – RH REAR	RR1 / 2-WAY REINSHAGEN METRI 630 / BLACK	WHEEL HUB

**HARNESSTO-HARNESSTO CONNECTORS**

Connector	Type / Color	Location / Access
AC13	20-WAY MULTILOCK 070 / YELLOW	FASCIA BOTTOM CONNECTOR MOUNTING BRACKET / RIGHT HAND SIDE
BT2	20-WAY MULTILOCK 070 / WHITE	TRUNK / ABOVE RIGHT HAND REAR WHEEL ARCH
BT72	4-WAY ECONOSEAL III LC / BLACK	REAR OF REAR HUB ASSEMBLY / LEFT HAND SIDE
BT73	4-WAY ECONOSEAL III LC / BLACK	REAR OF REAR HUB ASSEMBLY / RIGHT HAND SIDE
LF40	13-WAY ECONOSEAL III LC / BLACK	LHD: ENGINE COMPARTMENT / FORWARD OF BRAKE FLUID RESERVOIR RHD: ENGINE COMPARTMENT / BELOW CONTROL MODULE ENCLOSURE
LF41	2-WAY ECONOSEAL III LC / BLACK	ENGINE COMPARTMENT / ADJACENT TO ENGINE COMPARTMENT FUSE BOX
LF42	2-WAY ECONOSEAL III LC / BLACK	ENGINE COMPARTMENT / ADJACENT TO AIR CLEANER
LF60	20-WAY MULTILOCK 070 / WHITE	LEFT HAND 'A' POST CONNECTOR MOUNTING BRACKET / 'A' POST TRIM
RH1	20-WAY MULTILOCK 070 / GREY	BEHIND GLOVE BOX

**GROUNDS**

Ground	Location / Type
FC2BR	EYELET (PAIR) – RIGHT HAND LEG / RIGHT HAND 'A' POST
FC4BR	EYELET (PAIR) – RIGHT HAND LEG / LEFT HAND 'A' POST
LF3AS	EYELET (SINGLE) / ENGINE COMPARTMENT, FORWARD OF LEFT HAND HOOD CATCH

**FOR CONTROL MODULE PIN OUT INFORMATION, UNFOLD PAGE TO LEFT.**

The following abbreviations are used to represent values for Control Module Pin-Out data

I	Input	SG	Sensor Ground	S	SCP Network	V	Voltage (DC)
O	Output	A	ACP Network	D	Serial and Encoded Data	Hz	Frequency
SS	Sensor Supply V	C	CAN (Network)	B+	Battery Voltage	kHz	Frequency x 1000

**CAUTION:** The information on this data page is furnished to aid the user in understanding circuit operation. THIS INFORMATION SHOULD BE USED FOR REFERENCE ONLY.

**NOTE:** The values listed are approximately those that can be expected at the control module connector pins with all circuit connections made and all components connected and fitted. "Active" means a load is applied or a switch is ON; "Inactive" means a load is not applied or a switch is OFF.

Refer to the front of this book for detailed information and illustrations regarding the location and identification of harnesses, relays, grounds, control modules and control module pins.



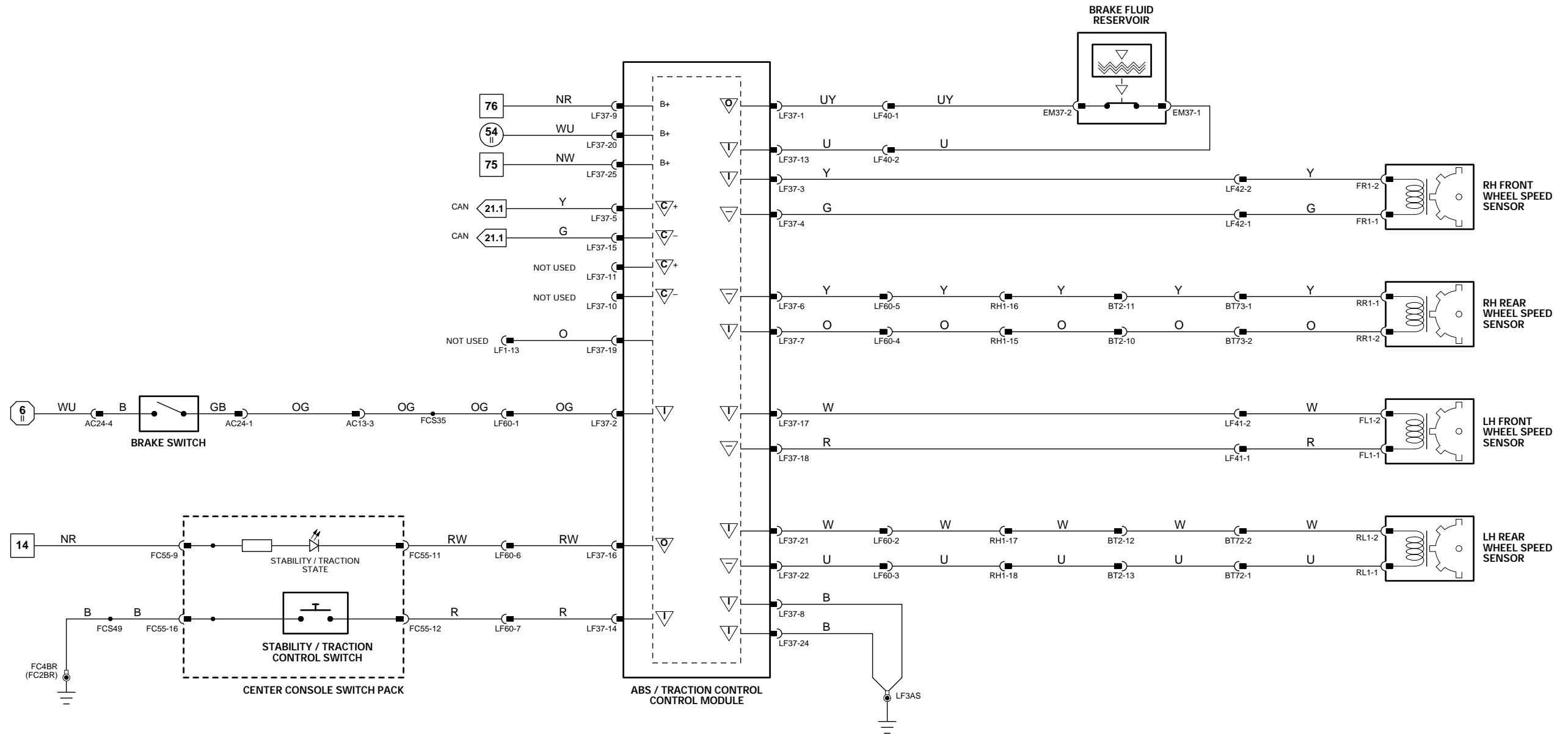

CONTROL MODULE PIN OUT INFORMATION

POWER ASSISTED STEERING CONTROL MODULE

Pin	Description	Active	Inactive
O FC16-2	TRANSDUCER NEGATIVE	2 V @ IDLE DECREASING WITH VEHICLE SPEED	
I FC16-4	VEHICLE SPEED	B+ @ 10 MPH (16 KM/H) = 20 Hz, 20 MPH (32 KM/H) = 40 Hz	
O FC16-5	TRANSDUCER POSITIVE	9 V @ IDLE INCREASING WITH VEHICLE SPEED	
I FC16-6	IGNITION SWITCHED POWER SUPPLY	B+	0 V
I FC16-8	GROUND	0 V	0 V

**Fig. 06.2**

COMPONENTS

Component	Connector / Type / Color	Location / Access
POWER ASSISTED STEERING CONTROL MODULE	FC16 / 9-WAY RISTS RELAY / BLACK AND RED	FASCIA / ADJACENT TO RH SIDE FUSE BOX
VARIABLE STEERING CONVERTER – LHD	LL2 / 2-WAY AMP JUNIOR POWER TIMER / BLACK	STEERING RACK / CONTROL VALVE
VARIABLE STEERING CONVERTER – RHD	EM18 / 2-WAY AMP JUNIOR POWER TIMER / NATURAL	STEERING RACK / CONTROL VALVE

HARNESS-TO-HARNESS CONNECTORS

Connector	Type / Color	Location / Access
EM2	18-WAY MULTILOCK 070 / YELLOW	ENGINE COMPARTMENT / ADJACENT TO RIGHT HAND ENCLOSURE
LL1	2-WAY ECONOSEAL III LC / BLACK	ENGINE COMPARTMENT / ADJACENT TO STARTER MOTOR

GROUNDS

Ground	Location / Type
FC2BR	EYELET (PAIR) – RIGHT HAND LEG / RIGHT HAND 'A' POST
FC4BR	EYELET (PAIR) – RIGHT HAND LEG / LEFT HAND 'A' POST

FOR CONTROL MODULE PIN OUT INFORMATION, UNFOLD PAGE TO LEFT.

The following abbreviations are used to represent values for Control Module Pin-Out data

I	Input	SG	Sensor Ground	S	SCP Network	V	Voltage (DC)
O	Output	A	ACP Network	D	Serial and Encoded Data	Hz	Frequency
SS	Sensor Supply V	C	CAN (Network)	B+	Battery Voltage	kHz	Frequency x 1000

CAUTION: The information on this data page is furnished to aid the user in understanding circuit operation. THIS INFORMATION SHOULD BE USED FOR REFERENCE ONLY.

NOTE: The values listed are approximately those that can be expected at the control module connector pins with all circuit connections made and all components connected and fitted. "Active" means a load is applied or a switch is ON; "Inactive" means a load is not applied or a switch is OFF.

Refer to the front of this book for detailed information and illustrations regarding the location and identification of harnesses, relays, grounds, control modules and control module pins.

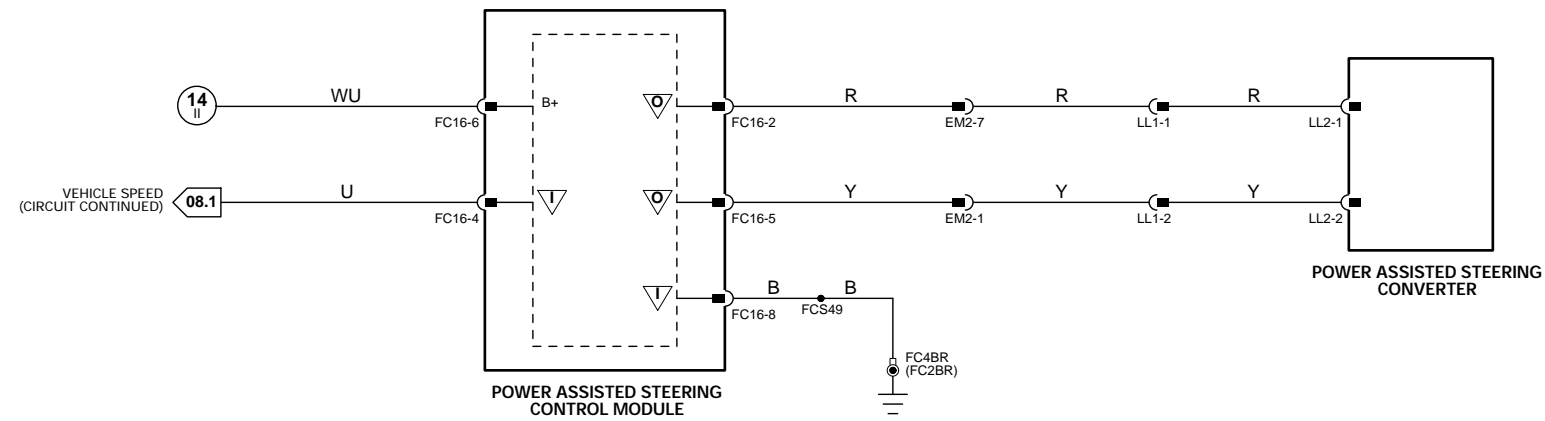

LHD

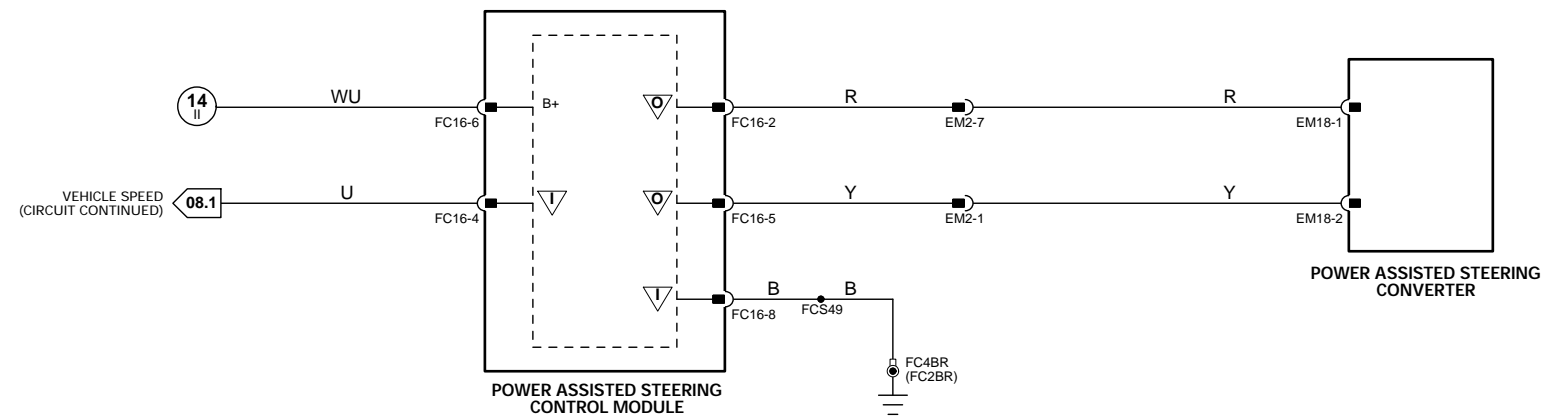

RHD

**CONTROL MODULE PIN OUT INFORMATION**

**Fig. 06.3**

**ADAPTIVE DAMPING CONTROL MODULE**

Pin	Description	Active	Inactive
O	BT69-1 MAJOR INSTRUMENT PACK ADAPTIVE DAMPING MIL	GROUND	B+
O	BT69-3 ACCELEROMETER COMMON GROUND SUPPLY	GROUND	GROUND
D	BT69-10 SERIAL COMMUNICATIONS		
I	BT69-11 IGNITION SWITCHED POWER SUPPLY	B+	GROUND
O	BT69-13 LH REAR DAMPER BATTERY POWER SUPPLY	B+	B+
O	BT69-14 RH FRONT DAMPER BATTERY POWER SUPPLY	B+	B+
O	BT69-15 RH REAR DAMPER BATTERY POWER SUPPLY	B+	B+
I	BT69-18 GROUND	GROUND	GROUND
I	BT69-20 FRONT LATERAL ACCELEROMETER FEEDBACK	< 0.2 V OR > 4.8 V	2.3 – 2.7 V = HARD
I	BT69-21 FRONT VERTICAL ACCELEROMETER FEEDBACK	< 0.2 V OR > 4.8 V	2.3 – 2.7 V = HARD
I	BT69-22 REAR VERTICAL ACCELEROMETER FEEDBACK	< 0.2 V OR > 4.8 V	2.3 – 2.7 V = HARD
I	BT69-24 VEHICLE SPEED SIGNAL	22 Hz @ 10 MPH (16 KM/H); 44 Hz @ 20 MPH (32 KM/H) @ B+	
O	BT69-25 ACCELEROMETER COMMON VOLTAGE SUPPLY	5 V	5 V
I	BT69-26 BRAKE SWITCH	GROUND	B+
I	BT69-27 BATTERY POWER SUPPLY	B+	B+
D	BT69-28 SERIAL COMMUNICATIONS		
O	BT69-30 LH FRONT DAMPER BATTERY POWER SUPPLY	B+	B+
O	BT69-31 LH FRONT DAMPER	GROUND	B+
O	BT69-32 LH REAR DAMPER	GROUND	B+
O	BT69-33 RH FRONT DAMPER	GROUND	B+
O	BT69-34 RH REAR DAMPER	GROUND	B+

**COMPONENTS**

Component	Connector / Type / Color	Location / Access
ACCELEROMETER – FRONT LATERAL	EM59 / 3-WAY AMP MQL / BLACK	ENGINE COMPARTMENT / ADJACENT TO ECM
ACCELEROMETER – REAR VERTICAL	BT52 / 3-WAY AMP MQL / BLACK	TRUNK / BELOW FUEL TANK
ACCELEROMETER – FRONT VERTICAL	FC7 / 3-WAY AMP MQL / BLACK	CENTER CONSOLE / BEHIND ICE HEAD UNIT
ADAPTIVE DAMPING CONTROL MODULE	BT69 / 35-WAY AMP / BLACK	TRUNK / ADJACENT TO ELECTRICAL CARRIER
BRAKE SWITCH	AC24 / 4-WAY MULTILOCK 070 / WHITE	TOP OF BRAKE PEDAL
DAMPER SOLENOID – LH FRONT	LF43 / 2-WAY DELPHI/REINSHAGEN / BLACK	TOP OF LEFT HAND FRONT DAMPER
DAMPER SOLENOID – LH REAR	DL2 / 2-WAY DELPHI/REINSHAGEN / BLACK	TOP OF LEFT HAND REAR DAMPER
DAMPER SOLENOID – RH FRONT	LF44 / 2-WAY DELPHI/REINSHAGEN / BLACK	TOP OF RIGHT HAND FRONT DAMPER
DAMPER SOLENOID – RH REAR	DR2 / 2-WAY DELPHI/REINSHAGEN / BLACK	TOP OF RIGHT HAND REAR DAMPER

**HARNESS-TO-HARNESS CONNECTORS**

Connector	Type / Color	Location / Access
AC13	20-WAY MULTILOCK 070 / YELLOW	FASCIA BOTTOM CONNECTOR MOUNTING BRACKET / RIGHT HAND SIDE
BT1	20-WAY MULTILOCK 070 / WHITE	TRUNK / ABOVE RIGHT HAND REAR WHEEL ARCH
BT3	18-WAY MULTILOCK 070 / YELLOW	TRUNK / ABOVE RIGHT HAND REAR WHEEL ARCH
BT72	4-WAY ECONOSEAL III LC / BLACK	TRUNK / BELOW FUEL TANK
BT73	4-WAY ECONOSEAL III LC / BLACK	TRUNK / BELOW FUEL TANK
EM3	14-WAY MULTILOCK 070 / GREY	ENGINE COMPARTMENT / ADJACENT TO RIGHT HAND ENCLOSURE
LF1	20-WAY MULTILOCK 070 / GREY	LEFT HAND 'A' POST CONNECTOR MOUNTING BRACKET / 'A' POST TRIM
LF60	20-WAY MULTILOCK 070 / WHITE	LEFT HAND 'A' POST CONNECTOR MOUNTING BRACKET / 'A' POST TRIM
RH1	20-WAY MULTILOCK 070 / GREY	BEHIND GLOVE BOX
RH12	18-WAY MULTILOCK 070 / YELLOW	REAR OF CENTER CONSOLE ASSEMBLY
RL3	2-WAY AUGAT 1.6 / BLACK	REAR OF REAR HUB ASSEMBLY / LEFT HAND SIDE
RR3	2-WAY AUGAT 1.6 / BLACK	REAR OF REAR HUB ASSEMBLY / RIGHT HAND SIDE

**GROUND**

Ground	Location / Type
BT2BL	EYELET (PAIR) – LEFT HAND LEG / TRUNK, RIGHT REAR

FOR CONTROL MODULE PIN OUT INFORMATION, UNFOLD PAGE TO LEFT.

The following abbreviations are used to represent values for Control Module Pin-Out data

I	Input	SG	Sensor Ground	S	SCP Network	V	Voltage (DC)
O	Output	A	ACP Network	D	Serial and Encoded Data	Hz	Frequency
SS	Sensor Supply V	C	CAN (Network)	B+	Battery Voltage	kHz	Frequency x 1000

**CAUTION:** The information on this data page is furnished to aid the user in understanding circuit operation. THIS INFORMATION SHOULD BE USED FOR REFERENCE ONLY.

**NOTE:** The values listed are approximately those that can be expected at the control module connector pins with all circuit connections made and all components connected and fitted. "Active" means a load is applied or a switch is ON; "Inactive" means a load is not applied or a switch is OFF.

Refer to the front of this book for detailed information and illustrations regarding the location and identification of harnesses, relays, grounds, control modules and control module pins.

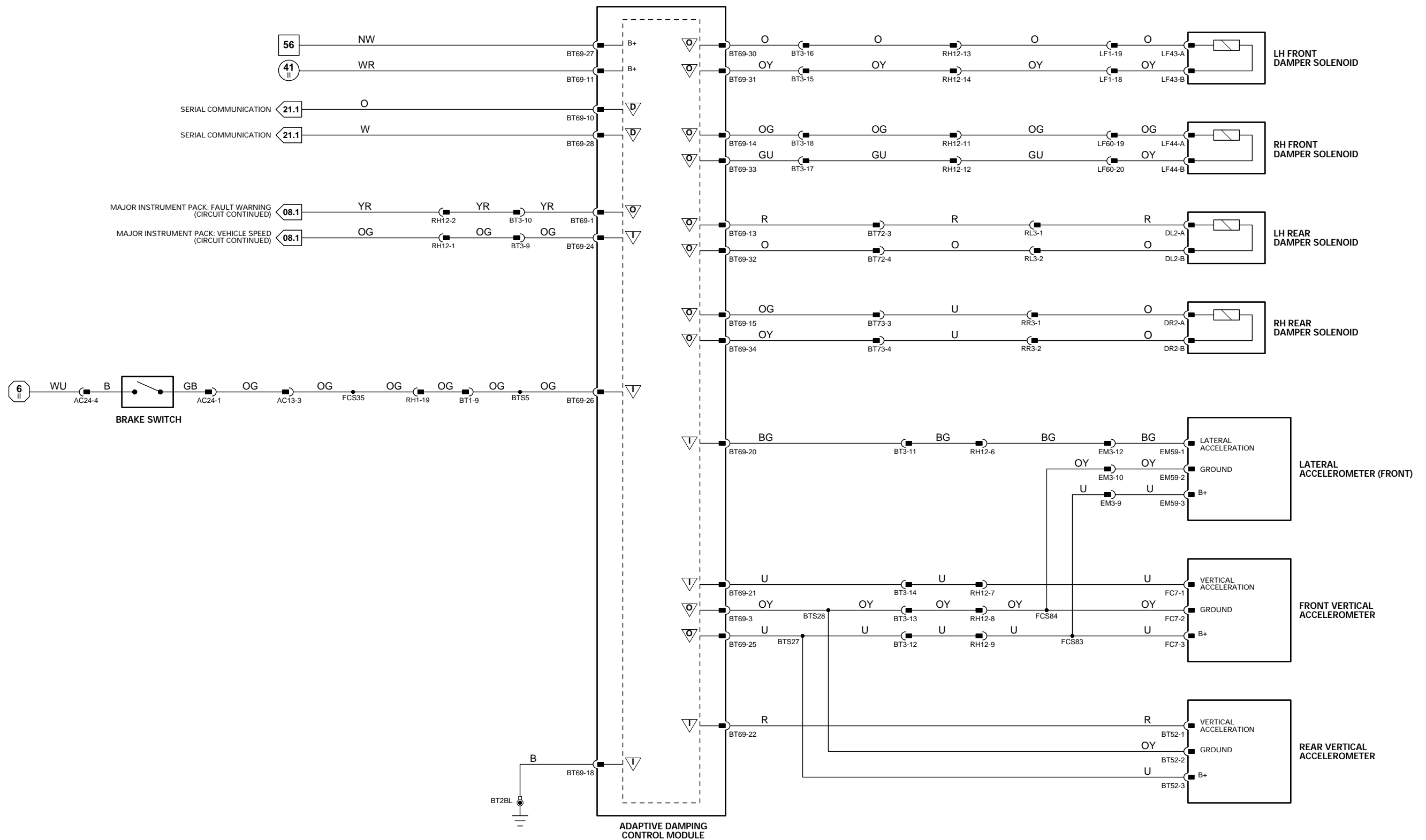

## CONTROL MODULE PIN OUT INFORMATION

### ADAPTIVE SPEED CONTROL BOOSTER CONTROL MODULE

Pin	Description	Active	Inactive
O AL4-01	AIR CONTROL VALVE SOLENOID DRIVE	PWM (-VE)	
SS AL4-02	RELEASE SWITCH REFERENCE VOLTAGE	5 V	5 V
SS AL4-04	BRAKE BOOSTER PRESSURE SENSOR 2 REFERENCE VOLTAGE	5 V	5 V
SG AL4-05	BRAKE BOOSTER PRESSURE SENSOR 2 SIGNAL GROUND	GROUND	GROUND
SG AL4-07	BRAKE BOOSTER PRESSURE SENSOR 1 SIGNAL GROUND	GROUND	GROUND
SS AL4-08	BRAKE BOOSTER PRESSURE SENSOR 1 REFERENCE VOLTAGE	5 V	5 V
O AL4-09	AIR CONTROL VALVE SOLENOID POWER SUPPLY	5 V	5 V
I AL4-10	RELEASE SWITCH NORMALLY OPEN	GROUND	5 V
I AL4-11	RELEASE SWITCH NORMALLY CLOSED	5 V	GROUND
I AL4-13	BRAKE BOOSTER PRESSURE SENSOR 2 FEEDBACK	0 – 5 V	
I AL4-16	BRAKE BOOSTER PRESSURE SENSOR 1 FEEDBACK	0 – 5 V	
I EM87-02	IGNITION SWITCHED SUPPLY	B+	B+
C EM87-03	CAN NETWORK	15 – 1500 Hz	
I EM87-06	BATTERY POWER SUPPLY	B+	B+
C EM87-07	CAN NETWORK	15 – 1500 Hz	
I EM87-10	POWER GROUND	GROUND	GROUND

### ADAPTIVE SPEED CONTROL CONTROL MODULE

Pin	Description	Active	Inactive
I LF61-01	BATTERY POWER SUPPLY	B+	B+
I LF61-02	POWER GROUND	GROUND	GROUND
I LF61-07	IGNITION SWITCHED POWER SUPPLY	B+	B+
C LF61-04	CAN NETWORK	15 – 1500 Hz	
C LF61-05	CAN NETWORK	15 – 1500 Hz	
C LF61-10	CAN NETWORK	15 – 1500 Hz	
C LF61-11	CAN NETWORK	15 – 1500 Hz	

### ENGINE CONTROL MODULE

Pin	Description	Active	Inactive
O EM80-16	SPEED CONTROL ON STATUS LED	GROUND	GROUND
I EM80-20	SPEED CONTROL BRAKE CANCEL REQUEST	GROUND	B+
I EM81-13	SPEED CONTROL ON REQUEST	B+	B+
I EM81-14	SPEED CONTROL SET +/-	7.3 V = (+), 8.8 V = (-)B+	GROUND
I EM81-15	SPEED CONTROL CANCEL / RESUME	7.3 V = RESUME, 8.8 V = CANCEL B+	
C EM83-15	CAN NETWORK	15 – 1500 Hz	
C EM83-16	CAN NETWORK	15 – 1500 Hz	
C EM83-24	CAN NETWORK	15 – 1500 Hz	
C EM83-25	CAN NETWORK	15 – 1500 Hz	

### TRANSMISSION CONTROL MODULE: AJ27 N/A

Pin	Description	Active	Inactive
C EM7-82	CAN NETWORK	15 – 1500 Hz	
C EM7-83	CAN NETWORK	15 – 1500 Hz	
C EM7-85	CAN NETWORK	15 – 1500 Hz	
C EM7-86	CAN NETWORK	15 – 1500 Hz	

NOTE: Refer to the Appendix at the rear of this book for CAN and SCP Network Messages.

The following abbreviations are used to represent values for Control Module Pin-Out data

I	Input	SG	Sensor Ground	S	SCP Network	V	Voltage (DC)
O	Output	A	ACP Network	D	Serial and Encoded Data	Hz	Frequency
SS	Sensor Supply V	C	CAN (Network)	B+	Battery Voltage	kHz	Frequency x 1000

CAUTION: The information on this data page is furnished to aid the user in understanding circuit operation. THIS INFORMATION SHOULD BE USED FOR REFERENCE ONLY.

NOTE: The values listed are approximately those that can be expected at the control module connector pins with all circuit connections made and all components connected and fitted. "Active" means a load is applied or a switch is ON; "Inactive" means a load is not applied or a switch is OFF.

Fig. 06.4

## COMPONENTS

Component	Connector / Type / Color	Location / Access
ADAPTIVE SPEED CONTROL BOOSTER	AL4 / 16-WAY / BLACK	ENGINE COMPARTMENT / CONTROL MODULE ENCLOSURE
ADAPTIVE SPEED CONTROL CONTROL MODULE	EM87 / 10-WAY AMP JUNIOR POWER TIMER / BLACK	
ADAPTIVE SPEED CONTROL MASTER SWITCH	AL1 / 6-WAY / BLACK	ADJACENT TO BRAKE FLUID RESERVOIR
BRAKE BOOSTER PRESSURE SENSOR 1	LF61 / 12-WAY ECONOSEAL III LC / BLACK	ENGINE COMPARTMENT / FORWARD OF RADIATOR
BRAKE BOOSTER PRESSURE SENSOR 2	FC63 / 10-WAY AMP MQL / NATURAL	REARWARD OF GEAR SELECTOR
BRAKE CANCEL SWITCH	AL2 / 3-WAY / BLACK	ADJACENT TO BRAKE FLUID RESERVOIR
ENGINE CONTROL MODULE	AL3 / 3-WAY / BLACK	ADJACENT TO BRAKE FLUID RESERVOIR
	AC24 / 4-WAY MULTILOCK 070 / WHITE	TOP OF BRAKE PEDAL
	EM80 / 31-WAY AMP 403 / NATURAL	ENGINE COMPARTMENT / CONTROL MODULE ENCLOSURE
	EM81 / 24-WAY AMP 403 / NATURAL	
	EM82 / 17-WAY AMP 403 / NATURAL	
	EM83 / 28-WAY AMP 403 / NATURAL	
	EM84 / 22-WAY AMP 403 / NATURAL	
	EM85 / 12-WAY MULTILOCK 070 / WHITE	
SPEED CONTROL SWITCHES (STEERING WHEEL)	SW3 / 3-WAY EPC / BLACK	CENTER OF STEERING WHEEL

## HARNESS-TO-HARNESS CONNECTORS

Connector	Type / Color	Location / Access
AC13	20-WAY MULTILOCK 070 / YELLOW	FASCIA BOTTOM CONNECTOR MOUNTING BRACKET / RIGHT HAND SIDE
EM3	14-WAY MULTILOCK 070 / GREY	ENGINE COMPARTMENT / ADJACENT TO RIGHT HAND ENCLOSURE
LF40	13-WAY ECONOSEAL III LC / BLACK	LHD: ENGINE COMPARTMENT / FORWARD OF BRAKE FLUID RESERVOIR RHD: ENGINE COMPARTMENT / BELOW CONTROL MODULE ENCLOSURE
SC3	12-WAY MULTILOCK 070 / GREY	RIGHT HAND SIDE OF STEERING COLUMN

## GROUNDS

Ground	Location / Type
EM1BR	EYELET (PAIR) – RIGHT HAND LEG / ENGINE COMPARTMENT, RIGHT HAND ENCLOSURE
EM2BR	EYELET (PAIR) – RIGHT HAND LEG / ENGINE COMPARTMENT, LEFT HAND ENCLOSURE
FC3BL	EYELET (PAIR) – LEFT HAND LEG / TRANSMISSION TUNNEL, LEFT HAND SIDE
LF1BS	EYELET (SINGLE) / RIGHT HAND HEADLAMP

FOR CONTROL MODULE PIN OUT INFORMATION, UNFOLD PAGE TO LEFT.

Refer to the front of this book for detailed information and illustrations regarding the location and identification of harnesses, relays, grounds, control modules and control module pins.

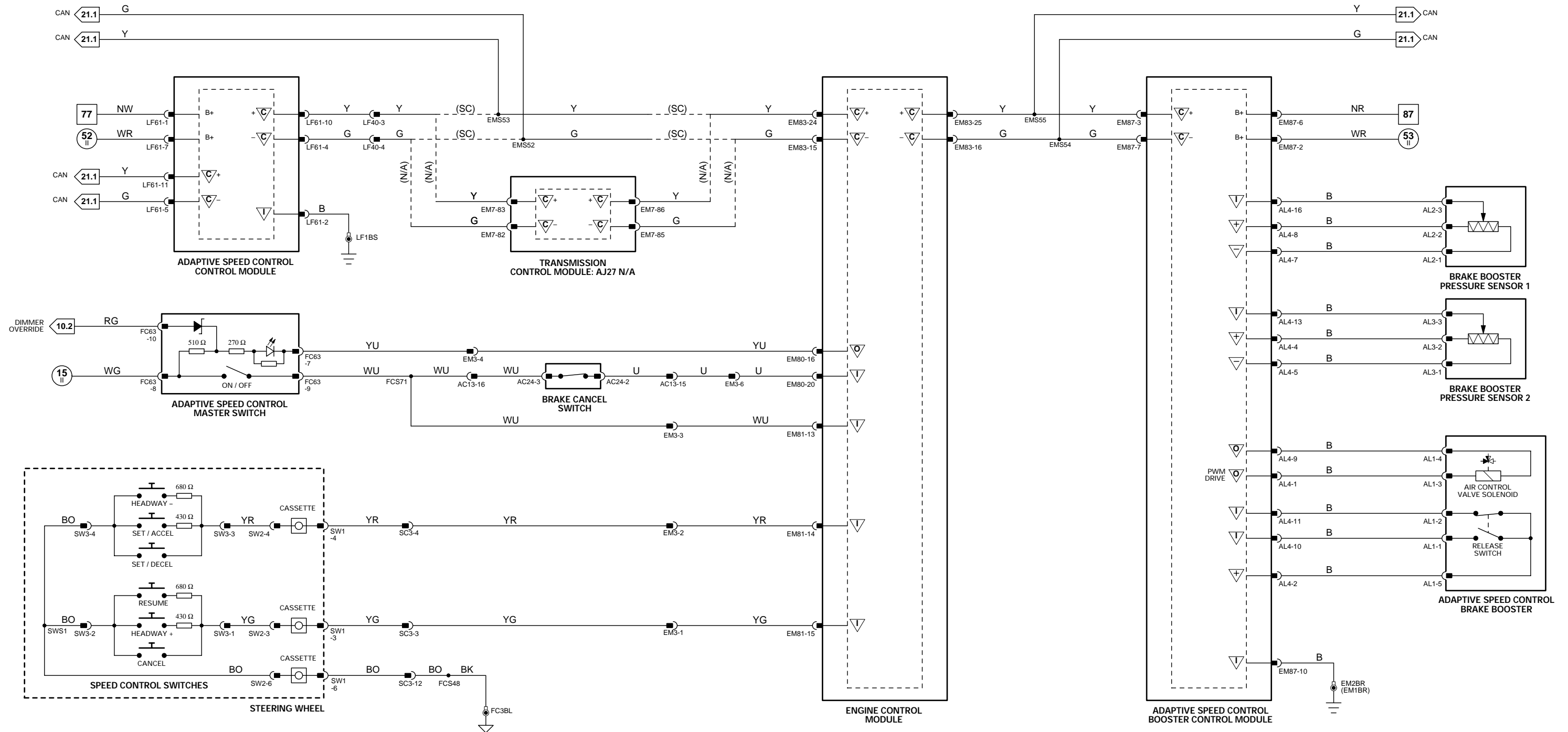

NOTE: ECM power supplies and grounds shown on Figs. 04.1, 04.3.

NOTE: Refer to Figs. 04.1 and 04.3 for the Throttle Control portion of Engine Management.

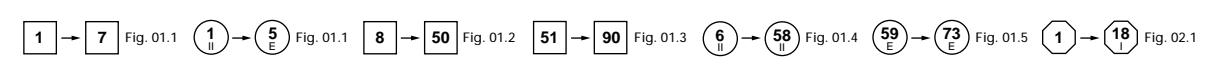

VARIANT: Adaptive Speed Control Vehicles  
 VIN RANGE: A11051 →  
 DATE OF ISSUE: September 2000

**CONTROL MODULE PIN OUT INFORMATION**

**AIR CONDITIONING CONTROL MODULE**

Pin	Description	Active	Inactive
O	AC1-6	DEFROST VENT SERVO MOTOR	B+
O	AC1-7	CENTER VENT SERVO MOTOR	B+
O	AC1-8	LH FRESH / RECIRCULATION VENT MOTOR	B+
O	AC1-9	RH FRESH / RECIRCULATION VENT MOTOR	B+
O	AC1-12	FOOTWELL VENT SERVO MOTOR	B+
O	AC1-13	COOL AIR BYPASS VENT SERVO MOTOR	B+
O	AC1-19	DEFROST VENT SERVO MOTOR	B+
O	AC1-20	CENTER VENT SERVO MOTOR	B+
O	AC1-21	LH FRESH / RECIRCULATION VENT SERVO MOTOR	B+
O	AC1-22	RH FRESH / RECIRCULATION VENT SERVO MOTOR	B+
O	AC1-25	FOOTWELL SERVO MOTOR	B+
O	AC1-26	COOL AIR BYPASS SERVO MOTOR	B+
I	AC2-1	SOLAR SENSOR FEEDBACK	0.75 V – 4.75 V; INCREASING WITH SOLAR LOAD
I	AC2-2	CENTER VENT POTENTIOMETER FEEDBACK	> 3.5 V = OPEN
I	AC2-3	RH FRESH / RECIRCULATION VENT POTENTIOMETER FEEDBACK	> 3.5 V = OPEN
I	AC2-5	COOL AIR BYPASS VENT POTENTIOMETER FEEDBACK	> 3.5 V = OPEN
I	AC2-6	ENGINE COOLANT TEMPERATURE	2.5 V @ 90° C; DECREASING WITH TEMPERATURE
I	AC2-10	DEFROST VENT POTENTIOMETER FEEDBACK	> 3.5 V = OPEN
I	AC2-11	LH FRESH / RECIRCULATION VENT POTENTIOMETER FEEDBACK	> 3.5 V = OPEN
I	AC2-13	FOOTWELL VENT POTENTIOMETER FEEDBACK	> 3.5 V = OPEN
O	AC3-2	CLOCK	B+ (1.45 Hz)
D	AC3-3	SERIAL DATA OUTPUT TO CONTROL PANEL	
I	AC3-5	AMBIENT TEMPERATURE SENSOR FEEDBACK	2.18 V @ 25° C; DECREASING WITH TEMPERATURE
I	AC3-6	HEATER MATRIX TEMPERATURE SENSOR FEEDBACK	2.25 V @ 20° C; DECREASING WITH TEMPERATURE
D	AC3-7	SERIAL DATA INPUT FROM CONTROL PANEL	
O	AC3-8	START	B+ (MOMENTARY)
I	AC3-11	IN CAR TEMPERATURE SENSOR FEEDBACK	3.25 V @ 0° C; DECREASING WITH TEMPERATURE
I	AC3-12	EVAPORATOR TEMPERATURE SENSOR FEEDBACK	3.25 V @ 0° C; DECREASING WITH TEMPERATURE
I	AC4-1	IGNITION SWITCHED POWER SUPPLY	B+
I	AC4-2	ISOLATE RELAY CONTROLLED BATTERY POWER SUPPLY	B+
I	AC4-3	IGNITION SWITCHED GROUND	0V
O	AC4-4	CONTROL PANEL BATTERY POWER SUPPLY	B+
I	AC4-5	BATTERY POWER SUPPLY	B+
I	AC4-6	ENGINE SPEED SIGNAL	5 V @ 1000 RPM = 45 Hz; 2000 RPM = 90 Hz
SS	AC4-8	POTENTIOMETER COMMON REFERENCE VOLTAGE	5 V
D	AC4-10	SERIAL COMMUNICATIONS INPUT	
O	AC4-12	CONTROL PANEL BATTERY POWER SUPPLY	B+
I	AC4-13	GROUND	0V
O	AC4-14	CONTROL PANEL GROUND SUPPLY	0V
O	AC4-15	ISOLATE RELAY ACTIVE	B+
I	AC4-16	VEHICLE SPEED SIGNAL	22 Hz @ 10 MPH (16 KM/H); 44 Hz @ 20 MPH (32 KM/H) @ B+
O	AC4-18	ASPIRATOR MOTOR POWER SUPPLY	B+
SG	AC4-19	POTENTIOMETER COMMON REFERENCE GROUND	0V
I	AC4-20	GROUND	0V
D	AC4-21	SERIAL COMMUNICATIONS OUTPUT	

**Fig. 07.1**

**COMPONENTS**

Component	Connector / Type / Color	Location / Access
AIR CONDITIONING CONTROL MODULE	AC1 / 26-WAY MULTILOCK 47 / GREY AC2 / 16-WAY MULTILOCK 47 / GREY AC3 / 12-WAY MULTILOCK 47 / GREY AC4 / 22-WAY MULTILOCK 47 / GREY	A/C UNIT / RIGHT HAND SIDE
AIR CONDITIONING CONTROL PANEL	FC43 / 12-WAY MULTILOCK 040 / BLUE	CENTER CONSOLE
AIR INTAKE – LH BLOWER	AC5 / 15-WAY SUMITOMO 090 HYBRID / GREEN	A/C UNIT / LEFT HAND SIDE
AIR INTAKE – RH BLOWER	AC6 / 15-WAY SUMITOMO 090 HYBRID / GREEN	A/C UNIT / RIGHT HAND SIDE
AMBIENT TEMPERATURE SENSOR	LF29 / 2-WAY YAZAKI 0902 / BLACK	ADJACENT TO RIGHT HAND HORN
ASPIRATOR ASSEMBLY	FC12 / 4-WAY MULTILOCK 070 / WHITE	DRIVER KNEE BOLSTER
EVAPORATOR / HEATER MATRIX ASSEMBLY	AC7 / 12-WAY MULTILOCK 040 / BLACK	A/C UNIT / LEFT HAND SIDE
SOLAR SENSOR	FC52 / 2-WAY MULTILOCK 070 / GREY	DRIVER SIDE FASCIA / ADJACENT TO DEFROST VENT
VENT ASSEMBLY	FC44 / 12-WAY MULTILOCK 040 / BLACK	A/C UNIT / TOP

**RELAYS**

Relay	Color / Stripe	Connector / Color	Location / Access
AIR CONDITIONING ISOLATE RELAY	BLACK	FC24 / BLACK	RH FASCIA RELAYS

**HARNESSTO-HARNESSTO CONNECTORS**

Connector	Type / Color	Location / Access
AC12	20-WAY MULTILOCK 070 / WHITE	FASCIA TOP CONNECTOR MOUNTING BRACKET / RIGHT HAND SIDE
AC13	20-WAY MULTILOCK 070 / YELLOW	FASCIA BOTTOM CONNECTOR MOUNTING BRACKET / RIGHT HAND SIDE
AC15	20-WAY MULTILOCK 070 / GREY	FASCIA BOTTOM CONNECTOR MOUNTING BRACKET / RIGHT HAND SIDE
AC15	20-WAY MULTILOCK 070 / GREY	FASCIA BOTTOM CONNECTOR MOUNTING BRACKET / RIGHT HAND SIDE
LF60	20-WAY MULTILOCK 070 / WHITE	LEFT HAND 'A' POST CONNECTOR MOUNTING BRACKET / 'A' POST TRIM

**GROUNDSTO**

Ground	Location / Type
FC2BR	EYELET (PAIR) – RIGHT HAND LEG / RIGHT HAND 'A' POST
FC3CS	EYELET (SINGLE) / TRANSMISSION TUNNEL, LEFT HAND SIDE
FC4BR	EYELET (PAIR) – RIGHT HAND LEG / LEFT HAND 'A' POST

FOR CONTROL MODULE PIN OUT INFORMATION, UNFOLD PAGE TO LEFT.

The following abbreviations are used to represent values for Control Module Pin-Out data

I	Input	SG	Sensor Ground	S	SCP Network	V	Voltage (DC)
O	Output	A	ACP Network	D	Serial and Encoded Data	Hz	Frequency
SS	Sensor Supply V	C	CAN (Network)	B+	Battery Voltage	kHz	Frequency x 1000

CAUTION: The information on this data page is furnished to aid the user in understanding circuit operation. THIS INFORMATION SHOULD BE USED FOR REFERENCE ONLY.

NOTE: The values listed are approximately those that can be expected at the control module connector pins with all circuit connections made and all components connected and fitted. "Active" means a load is applied or a switch is ON; "Inactive" means a load is not applied or a switch is OFF.

Refer to the front of this book for detailed information and illustrations regarding the location and identification of harnesses, relays, grounds, control modules and control module pins.





**NOTES:** When the ignition switched ground input is interrupted during engine cranking, the A/CCM does not drive high power consuming components.  
The A/C Isolate Relay remains energized by the A/CCM for 30 seconds after the ignition is switched OFF to provide power for the A/CCM to 'park' the servos.

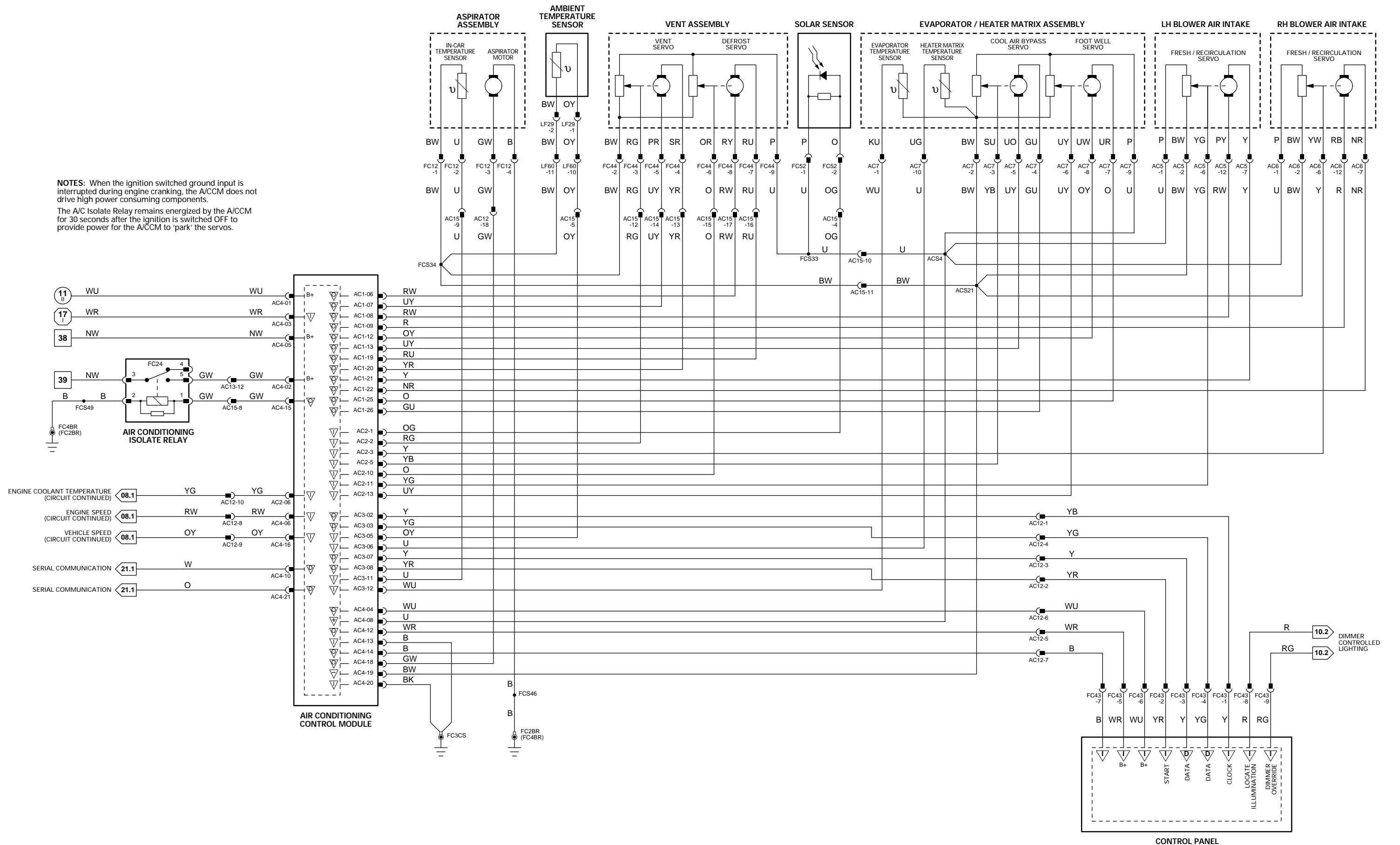

## CONTROL MODULE PIN OUT INFORMATION

### AIR CONDITIONING CONTROL MODULE

Pin	Description	Active	Inactive
I AC1-1	COMPRESSOR CLUTCH STATUS	B+ (ON)	0 V
O AC1-2	HEATER VALVE ACTIVE	B+	0 V
O AC1-3	RH BLOWER MOTOR RELAY ACTIVE	0 V	B+
O AC1-4	LH / RH WINDSHIELD HEATER RELAYS ACTIVATE	0 V	B+
O AC1-5	DOOR MIRROR HEATER RELAY ACTIVATE	0 V	0 V
O AC1-16	LH BLOWER MOTOR RELAY ACTIVATE	B+	0 V
O AC1-17	HEATER PUMP RELAY ACTIVATE	0 V	B+
O AC1-18	HEATED BACKLIGHT RELAY ACTIVATE	0 V	B+
I AC2-7	RH BLOWER SPEED FEEDBACK	7.6 V = LOW SPEED	0.83 V = HIGH SPEED
O AC2-8	RH BLOWER SPEED CONTROL DRIVE SIGNAL	1.3 V = LOW SPEED	0 V = HIGH SPEED
I AC2-15	LH BLOWER SPEED FEEDBACK	7.6 V = LOW SPEED	0.83 V = HIGH SPEED
O AC2-16	LH BLOWER SPEED CONTROL DRIVE SIGNAL	1.3 V = LOW SPEED	0 V = HIGH SPEED
O AC3-1	AIR CONDITIONING ELECTRICAL LOAD SIGNAL	B+	0 V
I AC4-7	LOAD INHIBIT	0 V	B+
O AC4-9	COMPRESSOR CLUTCH ON REQUEST	B+	0 V
I AC4-17	REFRIGERANT 4-WAY PRESSURE SWITCH	0 V (2 – 30 BAR)	B+ (OUT OF ACTIVE RANGE)

### ENGINE CONTROL MODULE

Pin	Description	Active	Inactive
I EM80-10	REFRIGERANT 4-WAY PRESSURE SWITCH HIGH PRESSURE	GROUND @ 20 BAR (290 PSI)	GROUND
I EM80-11	A/CCM COMPRESSOR CLUTCH REQUEST	B+	B+
O EM80-12	ELECTRICAL LOAD INHIBIT	GROUND	B+
I EM80-22	REFRIGERANT 4-WAY PRESSURE SWITCH HIGH PRESSURE	GROUND @ 12 BAR (174 PSI)	GROUND
I EM80-23	A/CCM ELECTRICAL LOAD REQUEST (HEATED WINDSHIELD)	B+	B+
O EM80-25	AIR CONDITIONING COMPRESSOR RELAY ACTIVATE	GROUND	B+
O EM81-04	PARALLEL (HIGH) SPEED FAN ACTIVATE	GROUND	B+
O EM81-05	SERIES (LOW) SPEED FAN ACTIVATE	GROUND	B+

Fig. 07.2

### COMPONENTS

Component	Connector / Type / Color	Location / Access
AIR CONDITIONING COMPRESSOR CLUTCH	PI36 / 1-WAY SUMITOMO 090 A-TYPE / BLACK	ENGINE COMPARTMENT / A/C COMPRESSOR
AIR CONDITIONING CONTROL MODULE	AC1 / 26-WAY MULTILOCK 47 / GREY AC2 / 16-WAY MULTILOCK 47 / GREY AC3 / 12-WAY MULTILOCK 47 / GREY AC4 / 22-WAY MULTILOCK 47 / GREY	A/C UNIT / RIGHT HAND SIDE
BLOWER MOTOR – LH	AC5 / 15-WAY SUMITOMO 090 HYBRID / GREEN	A/C UNIT / LEFT HAND SIDE
BLOWER MOTOR – RH	AC6 / 15-WAY SUMITOMO 090 HYBRID / GREEN	A/C UNIT / RIGHT HAND SIDE
ENGINE CONTROL MODULE	EM80 / 31-WAY AMP 403 / NATURAL EM81 / 24-WAY AMP 403 / NATURAL EM82 / 17-WAY AMP 403 / NATURAL EM83 / 28-WAY AMP 403 / NATURAL EM84 / 22-WAY AMP 403 / NATURAL EM85 / 12-WAY MULTILOCK 070 / WHITE	ENGINE COMPARTMENT / CONTROL MODULE ENCLOSURE
FUSE BOX – ENGINE COMPARTMENT	LF5 / 10-WAY U.T.A. FUSEBOX / NATURAL LF6 / 10-WAY U.T.A. FUSEBOX / BLACK LF7 / 10-WAY U.T.A. FUSEBOX / GREEN LF8 / 10-WAY U.T.A. FUSEBOX / BLUE LF70 / EYELET	ENGINE COMPARTMENT / LEFT FRONT
FUSE BOX – TRUNK	BT10 / 10-WAY U.T.A. FUSEBOX / NATURAL BT11 / 10-WAY U.T.A. FUSEBOX / BLACK BT12 / 10-WAY U.T.A. FUSEBOX / GREEN BT13 / 10-WAY U.T.A. FUSEBOX / BLUE BT64 / EYELET	TRUNK / ELECTRICAL CARRIER
HEATED BACKLIGHT	RH17 / 1-WAY LUCAR POSILOCK / BLACK RH18 / 1-WAY LUCAR POSILOCK / BLACK	BACKLIGHT / RIGHT HAND SIDE
HEATER PUMP	EM41 / 2-WAY ECONOSEAL III LC / BLACK	ENGINE COMPARTMENT / BULKHEAD, LEFT HAND SIDE
HEATER VALVE	EM43 / 2-WAY ECONOSEAL III LC / WHITE	ENGINE COMPARTMENT / BULKHEAD, LEFT HAND SIDE
MIRROR – DRIVER	DD8 / 12-WAY MULTILOCK 040 / BLACK	DRIVER DOOR
MIRROR – PASSENGER	DP8 / 12-WAY MULTILOCK 040 / BLACK	PASSENGER DOOR
RADIATOR FAN CONTROL RELAY MODULE	LF9 / 8-WAY TRW / BLACK	ADJACENT TO LEFT HAND HORN
RADIATOR FAN – LH	LF13 / 2-WAY REINSHAGEN METRI 630 / BLACK	ENGINE COMPARTMENT / FRONT
RADIATOR FAN – RH	LF12 / 2-WAY REINSHAGEN METRI 630 / BLACK	ENGINE COMPARTMENT / FRONT
REFRIGERANT 4-WAY PRESSURE SWITCH	LF57 / 6-WAY ECONOSEAL III LC / BLACK	ENGINE COMPARTMENT / REARWARD OF RADIATOR
WINDSHIELD HEATER – LH	EM49 / 2-WAY AMP SERIES 187C / GREY	ENGINE COMPARTMENT
WINDSHIELD HEATER – RH	EM48 / 2-WAY AMP SERIES 187C / GREY	ENGINE COMPARTMENT

### RELAYS

Relay	Color / Stripe	Connector / Color	Location / Access
AIR CONDITIONING COMPRESSOR CLUTCH RELAY	BROWN	BUS	LH ENCLOSURE RELAYS
BLOWER MOTOR RELAY – LH	BLACK	AC20 / BLACK	DRIVESHAFT TUNNEL RELAYS
BLOWER MOTOR RELAY – RH	BLACK	AC20 / BLACK	DRIVESHAFT TUNNEL RELAYS
DOOR MIRROR HEATER RELAY	BLACK	FC28 / BLACK	LH FASCIA RELAYS
HEATED BACKLIGHT RELAY (#2)	BROWN	BUS	TRUNK RELAYS
HEATER PUMP RELAY (#1)	BROWN	BUS	ENGINE COMPARTMENT FUSE BOX RELAYS
WINDSHIELD HEATER RELAY – LH	BROWN	EM44 / BROWN	RH ENCLOSURE RELAYS
WINDSHIELD HEATER RELAY – RH	BROWN	EM45 / BROWN	RH ENCLOSURE RELAYS

### HARNESSTO-HARNESSTO CONNECTORS

Connector	Type / Color	Location / Access
AC12	20-WAY MULTILOCK 070 / WHITE	FASCIA TOP CONNECTOR MOUNTING BRACKET / RIGHT HAND SIDE
AC13	20-WAY MULTILOCK 070 / YELLOW	FASCIA BOTTOM CONNECTOR MOUNTING BRACKET / RIGHT HAND SIDE
AC15	20-WAY MULTILOCK 070 / GREY	FASCIA BOTTOM CONNECTOR MOUNTING BRACKET / RIGHT HAND SIDE
BT2	20-WAY MULTILOCK 070 / WHITE	TRUNK / ABOVE RIGHT HAND REAR WHEEL ARCH
BT58	4-WAY ECONOSEAL III HC / BLACK	TRUNK / ABOVE RIGHT HAND REAR WHEEL ARCH
DD1	23-WAY AMP – FORD / BLACK	DRIVER SIDE 'A' POST MOUNTING BRACKET / 'A' POST TRIM
DP1	23-WAY AMP – FORD / BLACK	PASSENGER SIDE 'A' POST / 'A' POST TRIM
EM1	20-WAY MULTILOCK 070 / WHITE	ENGINE COMPARTMENT / ADJACENT TO RIGHT HAND ENCLOSURE
EM2	18-WAY MULTILOCK 070 / YELLOW	ENGINE COMPARTMENT / ADJACENT TO RIGHT HAND ENCLOSURE
LF3	13-WAY ECONOSEAL III LC / WHITE	LHD: ENGINE COMPARTMENT / ADJACENT TO BRAKE SERVO RHD: ENGINE COMPARTMENT / CONTROL MODULE ENCLOSURE
LF40	13-WAY ECONOSEAL III LC / BLACK	LHD: ENGINE COMPARTMENT / FORWARD OF BRAKE FLUID RESERVOIR RHD: ENGINE COMPARTMENT / BELOW CONTROL MODULE ENCLOSURE
LF60	20-WAY MULTILOCK 070 / WHITE	LEFT HAND 'A' POST CONNECTOR MOUNTING BRACKET / 'A' POST TRIM
PI1	57-WAY SUMITOMO TS090 / BLACK	ENGINE COMPARTMENT / BRACKET ON TOP OF TRANSMISSION
RH2	20-WAY MULTILOCK 070 / WHITE	REAR OF CENTER CONSOLE ASSEMBLY

### GROUNDS

Ground	Location / Type
EM1AR	EYELET (PAIR) – RIGHT HAND LEG / ENGINE COMPARTMENT, RIGHT HAND ENCLOSURE
EM1BL	EYELET (PAIR) – RIGHT HAND LEG / ENGINE COMPARTMENT, RIGHT HAND ENCLOSURE
EM1BS	EYELET (SINGLE) / ENGINE COMPARTMENT, RIGHT HAND ENCLOSURE
EM2AR	EYELET (PAIR) – RIGHT HAND LEG / ENGINE COMPARTMENT, LEFT HAND ENCLOSURE
EM2BL	EYELET (PAIR) – LEFT HAND LEG / ENGINE COMPARTMENT, LEFT HAND ENCLOSURE
EM2BS	EYELET (SINGLE) / ENGINE COMPARTMENT, LEFT HAND ENCLOSURE
FC2AL	EYELET (PAIR) – LEFT HAND LEG / RIGHT HAND 'A' POST
FC4AL	EYELET (PAIR) – LEFT HAND LEG / LEFT HAND 'A' POST
LF2AL	EYELET (PAIR) – LEFT HAND LEG / ENGINE COMPARTMENT, FORWARD OF LEFT HAND HOOD CATCH
LF2AR	EYELET (PAIR) – RIGHT HAND LEG / ENGINE COMPARTMENT, FORWARD OF LEFT HAND HOOD CATCH
LF2BL	EYELET (PAIR) – LEFT HAND LEG / ENGINE COMPARTMENT, FORWARD OF LEFT HAND HOOD CATCH
RH2S	EYELET (SINGLE) / LEFT HAND REAR QUARTER

FOR CONTROL MODULE PIN OUT INFORMATION, UNFOLD PAGE TO LEFT.

The following abbreviations are used to represent values for Control Module Pin-Out data

I	Input	SG	Sensor Ground	S	SCP Network	V	Voltage (DC)
O	Output	A	ACP Network	D	Serial and Encoded Data	Hz	Frequency
SS	Sensor Supply V	C	CAN (Network)	B+	Battery Voltage	kHz	Frequency x 1000

CAUTION: The information on this data page is furnished to aid the user in understanding circuit operation. THIS INFORMATION SHOULD BE USED FOR REFERENCE ONLY.

NOTE: The values listed are approximately those that can be expected at the control module connector pins with all circuit connections made and all components connected and fitted. "Active" means a load is applied or a switch is ON; "Inactive" means a load is not applied or a switch is OFF.

Refer to the front of this book for detailed information and illustrations regarding the location and identification of harnesses, relays, grounds, control modules and control module pins.

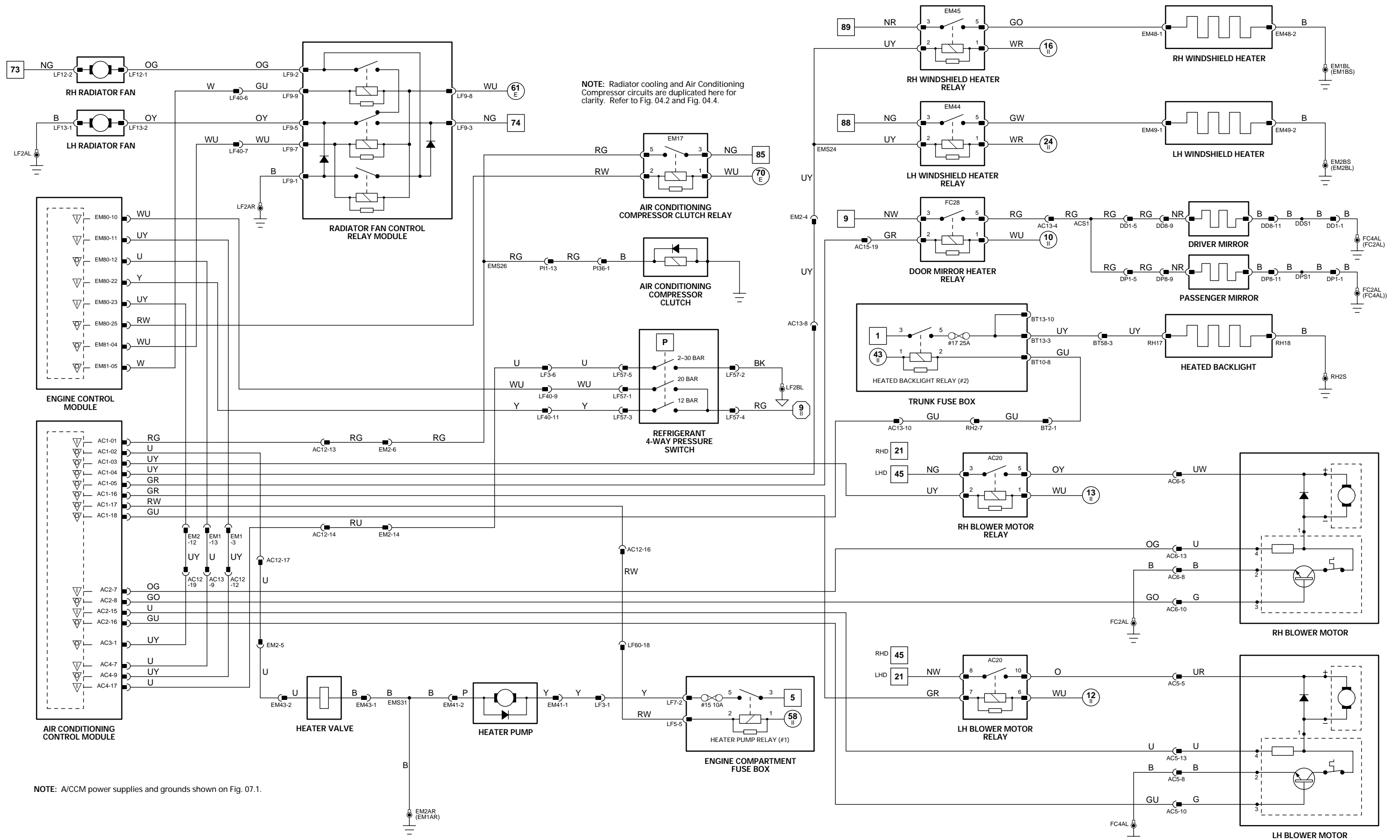

1 → 7 Fig. 01.1    1 → 5 Fig. 01.1    8 → 50 Fig. 01.2    51 → 90 Fig. 01.3    6 → 58 Fig. 01.4    59 → 73 Fig. 01.5    1 → 18 Fig. 02.1

▽ Input    ⊕ Sensor Supply V    ▽ ACP    ▽ SCP  
 ▽ Output    ▽ Sensor Ground    ▽ CAN    ▽ Serial and Encoded Data

**VARIANT:** All Vehicles  
**VIN RANGE:** A11051 →  
**DATE OF ISSUE:** September 2000

**CONTROL MODULE PIN OUT INFORMATION**

**Fig. 08.1**

**MAJOR INSTRUMENT PACK**

Pin	Description	Active	Inactive
I	FC25-01	IGNITION SWITCHED POWER SUPPLY	B+
O	FC25-02	MINOR INSTRUMENT PACK BATTERY POWER SUPPLY	B+
I	FC25-03	ADAPTIVE DAMPING WARNING	GROUND
I	FC25-04	GROUND	GROUND
I	FC25-06	ILLUMINATION SUPPLY	B+
I	FC25-07	TRIP CYCLE	GROUND (MOMENTARY)
I	FC25-08	'A/B' TRIP SELECT	GROUND (MOMENTARY)
I	FC25-09	'MLKM' SELECT	GROUND (MOMENTARY)
C	FC25-10	CAN NETWORK	15 – 1500 Hz
C	FC25-11	CAN NETWORK	15 – 1500 Hz
S	FC25-13	SCP NETWORK	2 – 1600 Hz
S	FC25-14	SCP NETWORK	2 – 1600 Hz
I	FC25-15	BATTERY POWER SUPPLY	B+
I	FC25-16	GROUND	GROUND
O	FC25-17	MINOR INSTRUMENT PACK ILLUMINATION SUPPLY	B+
I	FC25-18	'CLEAR' SELECT	GROUND (MOMENTARY)
I	FC25-19	'000' SELECT	GROUND (MOMENTARY)
C	FC25-23	CAN NETWORK	15 – 1500 Hz
C	FC25-24	CAN NETWORK	15 – 1500 Hz
O	FC25-25	GROUND REFERENCE	GROUND
O	FC26-1	BATTERY CHARGE WARNING	< 3 V
O	FC26-2	OIL PRESSURE WARNING	< 3 V = < 3 PSI
O	FC26-3	ENGINE SPEED	5 V @ 1000 RPM = 45 Hz; 2000 RPM = 90 Hz
O	FC26-4	ENGINE COOLANT TEMPERATURE	6 V = 90° C
O	FC26-5	VEHICLE SPEED – ACCM	22 Hz @ 10 MPH (16 KM/H); 44 Hz @ 20 MPH (32 KM/H) @ B+
O	FC26-6	VEHICLE SPEED – PAS	22 Hz @ 10 MPH (16 KM/H); 44 Hz @ 20 MPH (32 KM/H) @ B+
O	FC26-7	VEHICLE SPEED – ADAPTIVE DAMPING CONTROL MODULE	22 Hz @ 10 MPH (16 KM/H); 44 Hz @ 20 MPH (32 KM/H) @ B+
O	FC26-8	BATTERY VOLTAGE GAUGE POSITION FEEDBACK	5 V (MIDPOINT)
O	FC26-9	BATTERY VOLTAGE GAUGE POSITION FEEDBACK	5 V (MIDPOINT)
O	FC26-10	OIL PRESSURE GAUGE POSITION FEEDBACK	5 V = 0 PSI; 3.3 V = NORMAL (MIDPOINT)
O	FC26-11	BATTERY VOLTAGE GAUGE MOVEMENT	3.7 – 5 V (PULSE)
O	FC26-12	BATTERY VOLTAGE GAUGE MOVEMENT	3.7 – 5 V (PULSE)
I	FC26-13	FUEL LEVEL GAUGE FEEDBACK	B+ = EMPTY
O	FC26-14	FUEL LEVEL GAUGE REFERENCE GROUND	GROUND
O	FC26-15	OIL PRESSURE GAUGE POSITION FEEDBACK	5 V = 0 PSI; 3.3 V = NORMAL (MIDPOINT)
I	FC26-16	AIR BAG MIL	GROUND (ON)
O	FC26-17	OIL PRESSURE GAUGE MOVEMENT	3.7 – 5 V (PULSE)
O	FC26-18	OIL PRESSURE GAUGE MOVEMENT	3.7 – 5 V (PULSE)
I	FC26-19	LOW OIL PRESSURE WARNING	> 3 V => > 3 PSI
O	FC26-20	VEHICLE SPEED	22 Hz @ 10 MPH (16 KM/H); 44 Hz @ 20 MPH (32 KM/H) @ B+
I	FC26-21	DIMMER OVERRIDE	GROUND
I	FC26-22	CHARGE WARNING	B+
I	FC26-23	LOW COOLANT WARNING	GROUND

**MINOR INSTRUMENT PACK**

Pin	Description	Active	Inactive
I	FC79-8	MINOR INSTRUMENT PACK ILLUMINATION SUPPLY	B+
I	FC79-9	OIL PRESSURE GAUGE MOVEMENT	3.7 – 5 V (PULSE)
I	FC79-10	OIL PRESSURE GAUGE MOVEMENT	3.7 – 5 V (PULSE)
I	FC79-11	CHARGE WARNING	< 3 V
I	FC79-12	BATTERY VOLTAGE GAUGE POSITION FEEDBACK	5 V (MIDPOINT)
I	FC79-13	BATTERY VOLTAGE GAUGE POSITION FEEDBACK	5 V (MIDPOINT)
I	FC79-14	BATTERY VOLTAGE GAUGE MOVEMENT	3.7 – 5 V (PULSE)
I	FC79-15	BATTERY VOLTAGE GAUGE MOVEMENT	3.7 – 5 V (PULSE)
I	FC79-16	GROUND	GROUND
I	FC79-17	BATTERY POWER SUPPLY	B+
I	FC79-18	LOW OIL PRESSURE WARNING	GROUND (< 3 PSI)
I	FC79-19	OIL PRESSURE GAUGE POSITION FEEDBACK	5 V = 0 PSI; 3.3 V = NORMAL (MIDPOINT)
I	FC79-20	OIL PRESSURE GAUGE POSITION FEEDBACK	5 V = 0 PSI; 3.3 V = NORMAL (MIDPOINT)

**NOTE:** Refer to the Appendix at the rear of this book for CAN and SCP Network Messages.

The following abbreviations are used to represent values for Control Module Pin-Out data

<b>I</b>	<b>Input</b>	<b>SG</b>	<b>Sensor Ground</b>	<b>S</b>	<b>SCP Network</b>	<b>V</b>	<b>Voltage (DC)</b>
<b>O</b>	<b>Output</b>	<b>A</b>	<b>ACP Network</b>	<b>D</b>	<b>Serial and Encoded Data</b>	<b>Hz</b>	<b>Frequency</b>
<b>SS</b>	<b>Sensor Supply V</b>	<b>C</b>	<b>CAN (Network)</b>	<b>B+</b>	<b>Battery Voltage</b>	<b>kHz</b>	<b>Frequency x 1000</b>

**CAUTION:** The information on this data page is furnished to aid the user in understanding circuit operation. THIS INFORMATION SHOULD BE USED FOR REFERENCE ONLY.

**NOTE:** The values listed are approximately those that can be expected at the control module connector pins with all circuit connections made and all components connected and fitted. "Active" means a load is applied or a switch is ON; "Inactive" means a load is not applied or a switch is OFF.

**COMPONENTS**

Component	Connector / Type / Color	Location / Access
COOLANT LEVEL SWITCH	EM65 / 2-WAY AMP JUNIOR POWER TIMER / BROWN	ENGINE COMPARTMENT / COOLANT RESERVOIR
FUEL LEVEL SENSOR	FT3 / 6-WAY SUMITOMO DL090 / NATURAL	FUEL TANK EVAPORATIVE FLANGE
MAJOR INSTRUMENT PACK	FC25 / 26-WAY AMP MICRO QUAD LOCK / BLACK FC26 / 26-WAY AMP MICRO QUAD LOCK / YELLOW	FASCIA
MINOR INSTRUMENT PACK	FC79 / 20-WAY MULTILOCK 040 / BLACK	FASCIA
OIL PRESSURE SWITCH	PI40 / 1-WAY ECONOSEAL ECJ2 / BLACK	ENGINE BLOCK / RIGHT HAND SIDE
TRIP COMPUTER SWITCH PACK	FC27 / 10-WAY AMP MQL / BLACK	FASCIA / DRIVER SIDE
TRIP CYCLE SWITCH (COLUMN SWITCHGEAR)	SC2 / 10-WAY MULTILOCK 070 / YELLOW	STEERING COLUMN

**HARNESSTO-HARNESSTO CONNECTORS**

Connector	Type / Color	Location / Access
BT2	20-WAY MULTILOCK 070 / WHITE	TRUNK / ABOVE RIGHT HAND REAR WHEEL ARCH
EM1	20-WAY MULTILOCK 070 / WHITE	ENGINE COMPARTMENT / ADJACENT TO RIGHT HAND ENCLOSURE
EM2	18-WAY MULTILOCK 070 / YELLOW	ENGINE COMPARTMENT / ADJACENT TO RIGHT HAND ENCLOSURE
FT1	10-WAY MULTILOCK 070 / WHITE	FUEL TANK / REAR
PI1	57-WAY SUMITOMO TS090 / BLACK	ENGINE COMPARTMENT / BRACKET ON TOP OF TRANSMISSION
RH1	20-WAY MULTILOCK 070 / GREY	BEHIND GLOVE BOX

**GROUNDS**

Ground	Location / Type
EM1BR	EYELET (PAIR) – RIGHT HAND LEG / ENGINE COMPARTMENT, RIGHT HAND ENCLOSURE
EM2BR	EYELET (PAIR) – RIGHT HAND LEG / ENGINE COMPARTMENT, LEFT HAND ENCLOSURE
FC2BR	EYELET (PAIR) – RIGHT HAND LEG / RIGHT HAND 'A' POST
FC3BL	EYELET (PAIR) – LEFT HAND LEG / TRANSMISSION TUNNEL, LEFT HAND SIDE
FC4BR	EYELET (PAIR) – RIGHT HAND LEG / LEFT HAND 'A' POST

**FOR CONTROL MODULE PIN OUT INFORMATION, UNFOLD PAGE TO LEFT.**

Refer to the front of this book for detailed information and illustrations regarding the location and identification of harnesses, relays, grounds, control modules and control module pins.

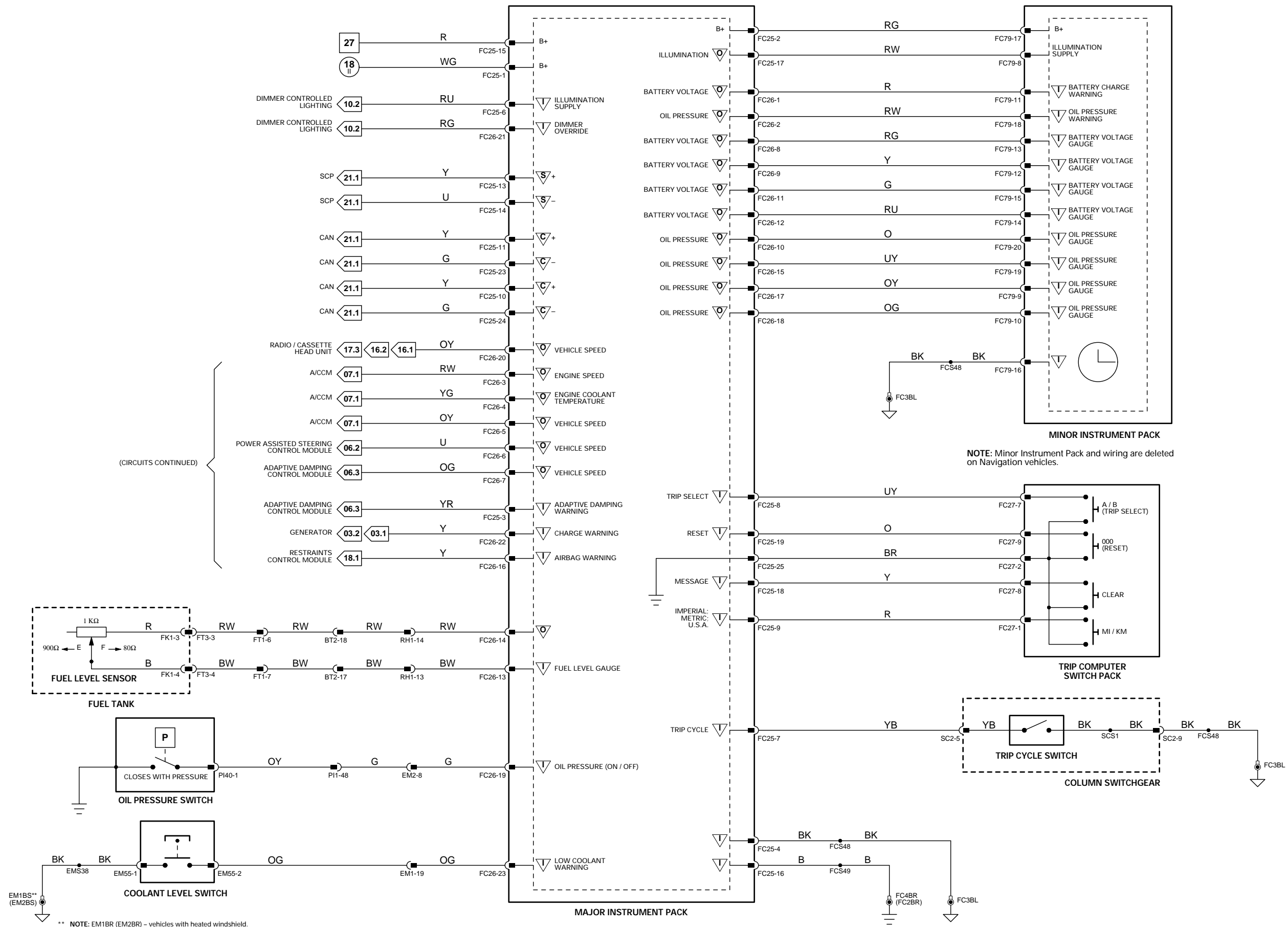

CONTROL MODULE PIN OUT INFORMATION

BODY PROCESSOR MODULE

	Pin	Description	Active	Inactive
I	FC14-8	AIRBAG WARNING	GROUND	B+
I	FC14-15	IGNITION SWITCHED GROUND SUPPLY	GROUND	
I	FC14-32	IGNITION SWITCHED GROUND SUPPLY	GROUND	GROUND
I	FC14-41	IGNITION SWITCHED GROUND SUPPLY	GROUND	
I	FC14-80	BATTERY POWER SUPPLY (LOGIC)	B+	B+
O	FC14-82	AUDIBLE WARNING SPEAKER OUTPUT	AUDIO OUTPUT	
O	FC14-83	AUDIBLE WARNING SPEAKER OUTPUT	AUDIO OUTPUT	
S	FC14-84	SCP NETWORK	2 – 1600 Hz	
S	FC14-85	SCP NETWORK	2 – 1600 Hz	
I	FC14-104	BATTERY POWER SUPPLY	B+	B+

NOTE: Refer to the Appendix at the rear of this book for CAN and SCP Network Messages.

Fig. 08.2

COMPONENTS

Component	Connector / Type / Color	Location / Access
AUDIBLE WARNING SPEAKER (COLUMN SWITCHGEAR)	SC1 / 12-WAY MULTILOCK 070 / WHITE	RIGHT HAND SIDE OF STEERING COLUMN
BODY PROCESSOR MODULE	FC14 / 104-WAY AMP EEEC / GREY	PASSENGER SIDE FASCIA / AIRBAG BRACKET

FOR CONTROL MODULE PIN OUT INFORMATION, UNFOLD PAGE TO LEFT.

The following abbreviations are used to represent values for Control Module Pin-Out data

I	Input	SG	Sensor Ground	S	SCP Network	V	Voltage (DC)
O	Output	A	ACP Network	D	Serial and Encoded Data	Hz	Frequency
SS	Sensor Supply V	C	CAN (Network)	B+	Battery Voltage	kHz	Frequency x 1000

CAUTION: The information on this data page is furnished to aid the user in understanding circuit operation. THIS INFORMATION SHOULD BE USED FOR REFERENCE ONLY.

NOTE: The values listed are approximately those that can be expected at the control module connector pins with all circuit connections made and all components connected and fitted. "Active" means a load is applied or a switch is ON; "Inactive" means a load is not applied or a switch is OFF.

Refer to the front of this book for detailed information and illustrations regarding the location and identification of harnesses, relays, grounds, control modules and control module pins.



SCP SOURCES:

- DIRECTION INDICATORS; HAZARD WARNING; SIDE LAMPS – Fig. 09.1, Fig. 09.2
- VALET SWITCH; TRUNK RELEASE – Fig. 13.1
- MEMORY – Fig. 11.1, Fig. 11.2, Fig. 12.1
- CONVERTIBLE TOP MOVEMENT – Fig. 15.2
- KEY-IN-IGNITION SWITCH / DRIVER DOOR SWITCH – Fig. 13.1
- NOT-IN-PARK MICROSWITCH – Fig. 05.3
- SEAT BELT SWITCH – Fig. 12.1, Fig. 12.2

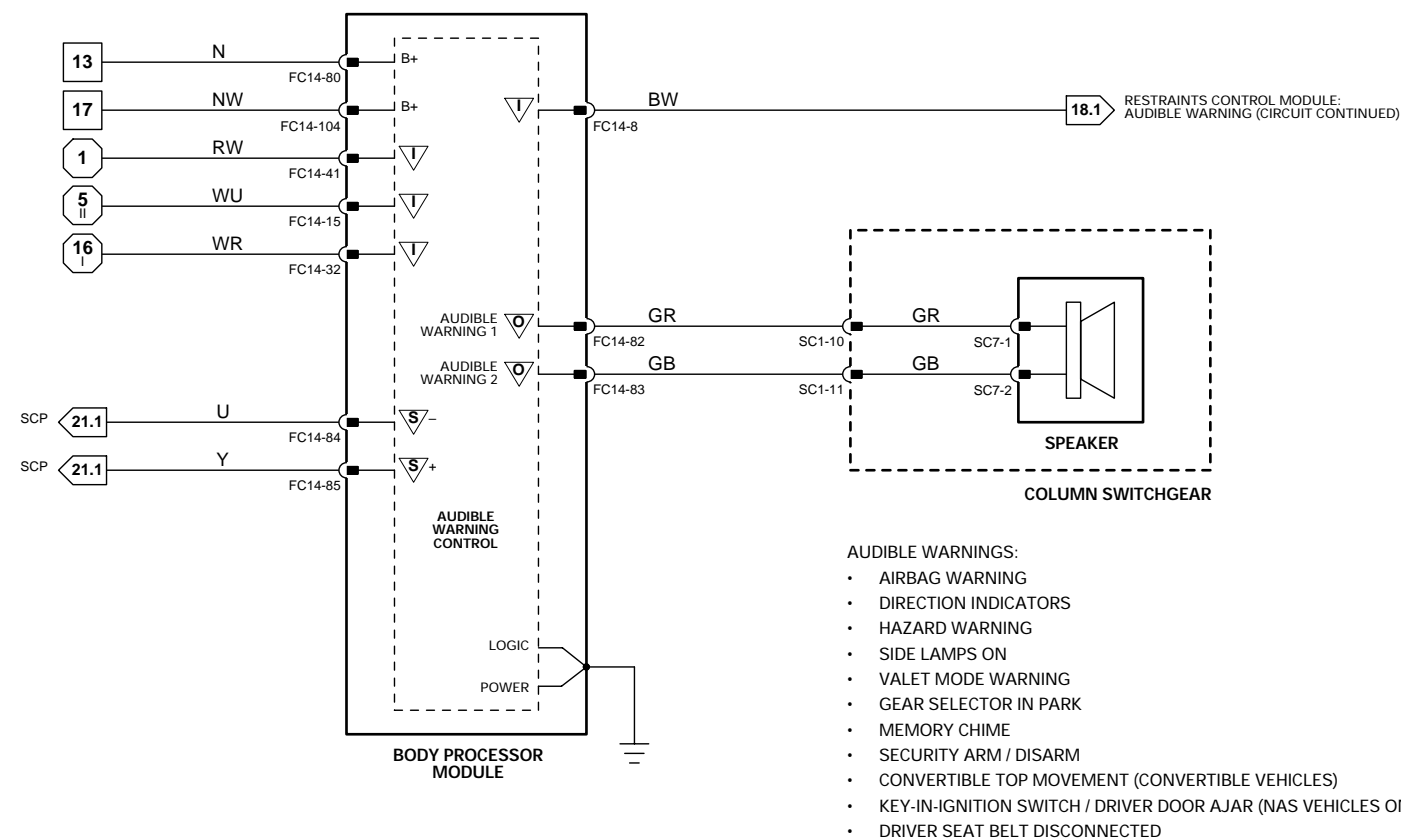

- AUDIBLE WARNINGS:
- AIRBAG WARNING
  - DIRECTION INDICATORS
  - HAZARD WARNING
  - SIDE LAMPS ON
  - VALET MODE WARNING
  - GEAR SELECTOR IN PARK
  - MEMORY CHIME
  - SECURITY ARM / DISARM
  - CONVERTIBLE TOP MOVEMENT (CONVERTIBLE VEHICLES)
  - KEY-IN-IGNITION SWITCH / DRIVER DOOR AJAR (NAS VEHICLES ONLY)
  - DRIVER SEAT BELT DISCONNECTED

**CONTROL MODULE PIN OUT INFORMATION**

**Fig. 09.1**

**BODY PROCESSOR MODULE**

Pin	Description	Active	Inactive
0	FC14-1	RH FRONT SIDE LAMP BULB SUPPLY	B+
0	FC14-2	LH FRONT DI BULB SUPPLY	B+ (PULSED)
0	FC14-3	RH FRONT DI BULB SUPPLY	B+ (PULSED)
I	FC14-14	HEADLAMP MAIN BEAM REQUEST	GROUND
I	FC14-15	IGNITION SWITCHED GROUND SUPPLY	GROUND
I	FC14-16	SIDE LAMP REQUEST	GROUND
0	FC14-20	FRONT FOG LAMP RELAY ACTIVATE / STATUS LED	GROUND (LIGHTS ON / LED ON)
0	FC14-27	LH SIDE DI REPEATER SUPPLY (ROW ONLY)	B+
0	FC14-28	RH SIDE DI REPEATER SUPPLY (ROW ONLY)	B+
I	FC14-30	HEADLAMP FLASH REQUEST	GROUND (MOMENTARY)
I	FC14-38	FRONT FOG LAMP SWITCH	GROUND (MOMENTARY)
I	FC14-41	IGNITION GROUND SUPPLY	GROUND
I	FC14-42	DIPPED BEAM REQUEST	GROUND
0	FC14-45	MAIN BEAM RELAY ACTIVATE	GROUND
0	FC14-53	LH FRONT SIDE LAMP SUPPLY	B+ (LIGHT ON)
0	FC14-54	LH SIDE MARKER SUPPLY (NAS ONLY)	B+ (LIGHT ON)
I	FC14-59	HAZARD LAMP REQUEST	GROUND (MOMENTARY)
I	FC14-61	RH DI REQUEST	GROUND
0	FC14-68	DIP BEAM RELAY ACTIVATE	GROUND (LIGHTS ON)
I	FC14-79	BATTERY POWER SUPPLY	B+
I	FC14-80	BATTERY POWER SUPPLY (LOGIC)	B+
0	FC14-81	RH SIDE DI REPEATER SUPPLY (ROW ONLY)	B+ (LIGHTS ON)
S	FC14-84	SCP NETWORK	2 - 1600 Hz
S	FC14-85	SCP NETWORK	2 - 1600 Hz
I	FC14-88	LH DI REQUEST	GROUND
0	FC14-96	HAZARD STATUS INDICATOR	B+ (PULSED)

**MAJOR INSTRUMENT PACK**

Pin	Description	Active	Inactive
S	FC25-13	SCP NETWORK	2 - 1600 Hz
S	FC25-14	SCP NETWORK	2 - 1600 Hz

**NOTE:** Refer to the Appendix at the rear of this book for CAN and SCP Network Messages.

The following abbreviations are used to represent values for Control Module Pin-Out data

I	Input	SG	Sensor Ground	S	SCP Network	V	Voltage (DC)
O	Output	A	ACP Network	D	Serial and Encoded Data	Hz	Frequency
SS	Sensor Supply V	C	CAN (Network)	B+	Battery Voltage	kHz	Frequency x 1000

**CAUTION:** The information on this data page is furnished to aid the user in understanding circuit operation. THIS INFORMATION SHOULD BE USED FOR REFERENCE ONLY.

**NOTE:** The values listed are approximately those that can be expected at the control module connector pins with all circuit connections made and all components connected and fitted. "Active" means a load is applied or a switch is ON; "Inactive" means a load is not applied or a switch is OFF.

**COMPONENTS**

Component	Connector / Type / Color	Location / Access
BODY PROCESSOR MODULE	FC14 / 104-WAY AMP EEEC / GREY	PASSENGER SIDE FASCIA / AIRBAG BRACKET
CENTER CONSOLE SWITCH PACK	FC55 / 20-WAY FORD IDC / BLACK	CENTER CONSOLE
FRONT FOG LAMP - LH	LF32 / 2-WAY REINSHAGEN METRI 630 / BLACK	FRONT BUMPER / WHEEL ARCH LINER PANEL
FRONT FOG LAMP - RH	LF22 / 2-WAY REINSHAGEN METRI 630 / BLACK	FRONT BUMPER / WHEEL ARCH LINER PANEL
FRONT LAMP UNIT - LH	LF31 / 6-WAY ECONOSEAL III LC / BLACK	LEFT HAND HEADLAMP ASSEMBLY
FRONT LAMP UNIT - RH	LF21 / 6-WAY ECONOSEAL III LC / BLACK	RIGHT HAND HEADLAMP ASSEMBLY
FUSE BOX - ENGINE COMPARTMENT	LF5 / 10-WAY U.T.A. FUSEBOX / NATURAL LF6 / 10-WAY U.T.A. FUSEBOX / BLACK LF7 / 10-WAY U.T.A. FUSEBOX / GREEN LF8 / 10-WAY U.T.A. FUSEBOX / BLUE LF70 / EYELET	ENGINE COMPARTMENT / LEFT FRONT
LIGHTING STALK (COLUMN SWITCHGEAR)	SC2 / 10-WAY MULTILOCK 070 / YELLOW	STEERING COLUMN
MAJOR INSTRUMENT PACK	FC25 / 26-WAY AMP MICRO QUAD LOCK / BLACK FC26 / 26-WAY AMP MICRO QUAD LOCK / YELLOW	FASCIA
SIDE DI REPEATER - LH (ROW)	LF4 / 2-WAY AMP JUNIOR POWER TIMER / BLACK	BEHIND WHEEL ARCH LINER
SIDE DI REPEATER - RH (ROW)	EL5 / 2-WAY AMP JUNIOR POWER TIMER / BLACK	BEHIND WHEEL ARCH LINER
FRONT SIDE MARKER - LH (NAS ONLY)	LF11 / 2-WAY AMP JUNIOR POWER TIMER / BLACK	BEHIND WHEEL ARCH LINER
FRONT SIDE MARKER - RH (NAS ONLY)	LF10 / 2-WAY AMP JUNIOR POWER TIMER / BLACK	BEHIND WHEEL ARCH LINER

**RELAYS**

Relay	Color / Stripe	Connector / Color	Location / Access
DIP BEAM RELAY (#5)	BROWN	BUS	ENGINE COMPARTMENT FUSE BOX
FRONT FOG RELAY (#2)	BROWN	BUS	ENGINE COMPARTMENT FUSE BOX
MAIN BEAM RELAY (#3)	BROWN	BUS	ENGINE COMPARTMENT FUSE BOX

**HARNESSTO-HARNESSTO CONNECTORS**

Connector	Type / Color	Location / Access
EL6	2-WAY ECONOSEAL III LC / BLACK	ENGINE COMPARTMENT / ADJACENT TO RIGHT HAND ENCLOSURE
EM2	18-WAY MULTILOCK 070 / YELLOW	ENGINE COMPARTMENT / ADJACENT TO RIGHT HAND ENCLOSURE
LF1	20-WAY MULTILOCK 070 / GREY	LEFT HAND 'A' POST CONNECTOR MOUNTING BRACKET / 'A' POST TRIM

**GROUNDS**

Ground	Location / Type
EM1AR	EYELET (PAIR) - RIGHT HAND LEG / ENGINE COMPARTMENT, RIGHT HAND ENCLOSURE
EM2AR	EYELET (PAIR) - RIGHT HAND LEG / ENGINE COMPARTMENT, LEFT HAND ENCLOSURE
FC2BR	EYELET (PAIR) - RIGHT HAND LEG / RIGHT HAND 'A' POST
FC3BL	EYELET (PAIR) - LEFT HAND LEG / TRANSMISSION TUNNEL, LEFT HAND SIDE
FC3BR	EYELET (PAIR) - RIGHT HAND LEG / TRANSMISSION TUNNEL, LEFT HAND SIDE
FC4BR	EYELET (PAIR) - RIGHT HAND LEG / LEFT HAND 'A' POST
LF1AL	EYELET (PAIR) - LEFT HAND LEG / RIGHT HAND HEADLAMP
LF2BR	EYELET (PAIR) - RIGHT HAND LEG / ENGINE COMPARTMENT, FORWARD OF LEFT HAND HOOD CATCH

**FOR CONTROL MODULE PIN OUT INFORMATION, UNFOLD PAGE TO LEFT.**

Refer to the front of this book for detailed information and illustrations regarding the location and identification of harnesses, relays, grounds, control modules and control module pins.



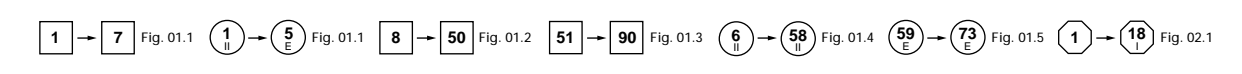
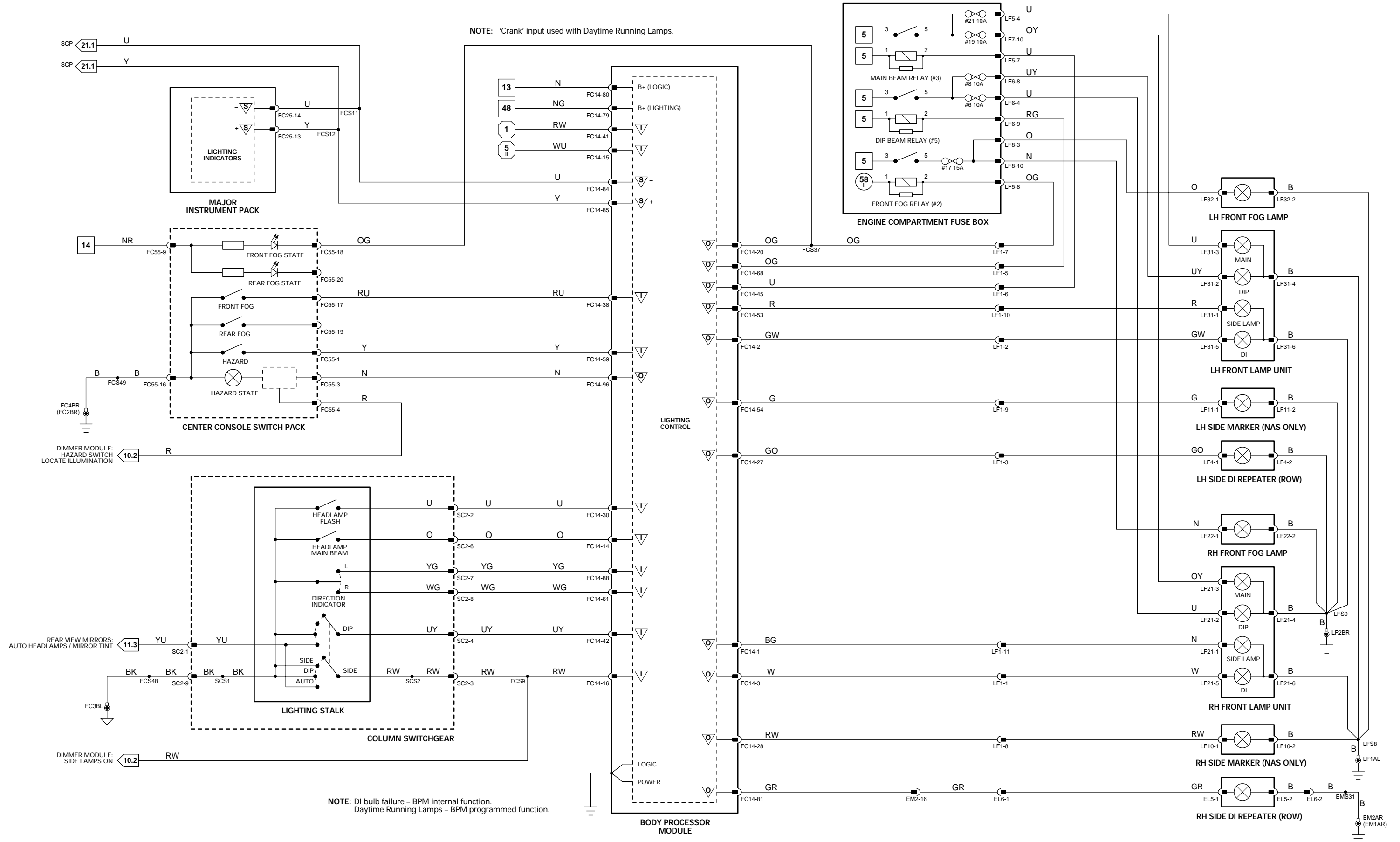

VARIANT: All Vehicles  
 VIN RANGE: A11051 →  
 DATE OF ISSUE: September 2000

## CONTROL MODULE PIN OUT INFORMATION

### BODY PROCESSOR MODULE

Pin	Description	Active	Inactive
I FC14-12	REAR FOG LAMP REQUEST	GROUND (MOMENTARY)	B+
I FC14-15	IGNITION SWITCHED GROUND SUPPLY	GROUND	
I FC14-16	SIDE LAMP REQUEST	GROUND	B+
I FC14-41	IGNITION GROUND SUPPLY	GROUND	
I FC14-42	DIPPED BEAM REQUEST	GROUND	B+
O FC14-44	REAR FOG LAMP STATUS LED	GROUND (LED ON)	B+
O FC14-50	LH REAR DI LAMP SUPPLY	B+ (LIGHT ON)	GROUND
I FC14-61	RH DI REQUEST	GROUND	B+
O FC14-76	RH REAR DI LAMP SUPPLY	B+ (LIGHTS ON)	GROUND
I FC14-79	BATTERY POWER SUPPLY	B+	B+
I FC14-80	BATTERY POWER SUPPLY (LOGIC)	B+	B+
S FC14-84	SCP NETWORK	2 – 1600 Hz	
S FC14-85	SCP NETWORK	2 – 1600 Hz	
I FC14-88	LH DI REQUEST	GROUND	B+
O FC14-95	TAIL LAMP RELAY ACTIVATE	GROUND (LIGHTS ON)	B+
I FC14-104	LIGHTING / MOTORS BATTERY POWER SUPPLY	B+	B+

### MAJOR INSTRUMENT PACK

Pin	Description	Active	Inactive
C FC25-11	CAN NETWORK	15 – 1500 Hz	
S FC25-13	SCP NETWORK	2 – 1600 Hz	
S FC25-14	SCP NETWORK	2 – 1600 Hz	
C FC25-23	CAN NETWORK	15 – 1500 Hz	

### SECURITY AND LOCKING CONTROL MODULE

Pin	Description	Active	Inactive
O BT40-5	REVERSE LAMP SUPPLY	B+	GROUND
I BT40-6	BATTERY POWER SUPPLY	B+	B+
O BT40-7	REAR FOG LAMP RELAY ACTIVATE	GROUND	B+
S BT40-8	SCP NETWORK	2 – 1600 Hz	
I BT40-13	GROUND	GROUND	GROUND
I BT40-14	GROUND	GROUND	GROUND
S BT40-16	SCP NETWORK	2 – 1600 Hz	
O BT41-12	SIDE MARKER LAMP SUPPLY	B+	GROUND
I BT41-13	SIDE MARKER LAMP SUPPLY	B+	GROUND
O BT42-1	RH STOP LAMP SUPPLY	B+	GROUND
O BT42-2	LH STOP LAMP SUPPLY	B+	GROUND
O BT42-3	RH TAIL LAMP SUPPLY	B+	GROUND
O BT42-4	LH TAIL LAMP SUPPLY	B+	GROUND
O BT42-5	NUMBER PLATE LAMP SUPPLY	B+	GROUND
I BT42-6	RH STOP LAMP SUPPLY	B+	GROUND
I BT42-7	LH STOP LAMP SUPPLY	B+	GROUND
I BT42-8	RH TAIL LAMP SUPPLY	B+	GROUND
I BT42-9	LH TAIL LAMP SUPPLY	B+	GROUND
I BT42-10	NUMBER PLATE LAMP SUPPLY	B+	GROUND

**NOTE:** Refer to the Appendix at the rear of this book for CAN and SCP Network Messages.

The following abbreviations are used to represent values for Control Module Pin-Out data

I	Input	SG	Sensor Ground	S	SCP Network	V	Voltage (DC)
O	Output	A	ACP Network	D	Serial and Encoded Data	Hz	Frequency
SS	Sensor Supply V	C	CAN (Network)	B+	Battery Voltage	kHz	Frequency x 1000

**CAUTION:** The information on this data page is furnished to aid the user in understanding circuit operation. THIS INFORMATION SHOULD BE USED FOR REFERENCE ONLY.

**NOTE:** The values listed are approximately those that can be expected at the control module connector pins with all circuit connections made and all components connected and fitted. “Active” means a load is applied or a switch is ON; “Inactive” means a load is not applied or a switch is OFF.

## Fig. 09.2

### COMPONENTS

Component	Connector / Type / Color	Location / Access
BODY PROCESSOR MODULE	FC14 / 104-WAY AMP EEEC / GREY	PASSENGER SIDE FASCIA / AIRBAG BRACKET
BRAKE SWITCH	AC24 / 4-WAY MULTILOCK 070 / WHITE	TOP OF BRAKE PEDAL
CENTER CONSOLE SWITCH PACK	FC55 / 20-WAY FORD IDC / BLACK	CENTER CONSOLE
FUSE BOX – TRUNK	BT10 / 10-WAY U.T.A. FUSEBOX / NATURAL BT11 / 10-WAY U.T.A. FUSEBOX / BLACK BT12 / 10-WAY U.T.A. FUSEBOX / GREEN BT13 / 10-WAY U.T.A. FUSEBOX / BLUE BT64 / EYELET	TRUNK / ELECTRICAL CARRIER
HIGH MOUNT STOP LAMP (CONV.)	BL8 / 2-WAY MULTILOCK 070 / WHITE	TRUNK / UNDERSIDE OF LID
HIGH MOUNT STOP LAMP (COUPE)	RH8 / 2-WAY MULTILOCK 070 / WHITE	TRUNK / REARWARD OF SUB WOOFER SPEAKER
LAMP CONTROL MODULE	BT18 / 26-WAY AMP MQS / YELLOW	TRUNK / ELECTRICAL CARRIER
LIGHTING STALK (COLUMN SWITCHGEAR)	SC2 / 10-WAY MULTILOCK 070 / YELLOW	STEERING COLUMN
MAJOR INSTRUMENT PACK	FC25 / 26-WAY AMP MICRO QUAD LOCK / BLACK FC26 / 26-WAY AMP MICRO QUAD LOCK / YELLOW	FASCIA
NUMBER PLATE LAMP – LH	BL4 / 2-WAY AMP JUNIOR POWER TIMER / BLACK	TRUNK LID / LINER
NUMBER PLATE LAMP – RH	BL5 / 2-WAY AMP JUNIOR POWER TIMER / BLACK	TRUNK LID / LINER
SECURITY AND LOCKING CONTROL MODULE	BT40 / 16-WAY FORD 2.8 TIMER / BLACK BT41 / 26-WAY FORD IDC / BLACK BT42 / 10-WAY FORD 2.8 TIMER / BLACK RH20 / COAXIAL CONNECTOR	TRUNK / ELECTRICAL CARRIER
REAR SIDE MARKER – LH (NAS ONLY)	BT27 / 2-WAY AMP JUNIOR POWER TIMER / BLACK	TRUNK / LEFT HAND SIDE
REAR SIDE MARKER – RH (NAS ONLY)	BT26 / 2-WAY AMP JUNIOR POWER TIMER / BLACK	TRUNK / RIGHT HAND SIDE
TAIL LAMP UNIT – LH	BT31 / 7-WAY FORD 2.8 TIMER / BLACK	TRUNK / LEFT HAND SIDE
TAIL LAMP UNIT – RH	BT30 / 7-WAY FORD 2.8 TIMER / BLACK	TRUNK / RIGHT HAND SIDE

### RELAYS

Relay	Color / Stripe	Connector / Color	Location / Access
REAR FOG RELAY (#1)	BROWN	BUS	TRUNK FUSE BOX
STOP LAMP RELAY (#5)	BROWN	BUS	TRUNK FUSE BOX
TAIL LAMP RELAY (#3)	BROWN	BUS	TRUNK FUSE BOX

### HARNESS-TO-HARNESS CONNECTORS

Connector	Type / Color	Location / Access
AC13	20-WAY MULTILOCK 070 / YELLOW	FASCIA BOTTOM CONNECTOR MOUNTING BRACKET / RIGHT HAND SIDE
BB1	4-WAY MULTILOCK 070 / WHITE	TRUNK / ABOVE RIGHT HAND REAR WHEEL ARCH
BL1	4-WAY MULTILOCK 070 / WHITE	TRUNK / ABOVE RIGHT HAND REAR WHEEL ARCH
BT1	20-WAY MULTILOCK 070 / WHITE	TRUNK / ABOVE RIGHT HAND REAR WHEEL ARCH
BT2	20-WAY MULTILOCK 070 / WHITE	TRUNK / ABOVE RIGHT HAND REAR WHEEL ARCH
RH1	20-WAY MULTILOCK 070 / GREY	BEHIND GLOVE BOX
RH2	20-WAY MULTILOCK 070 / WHITE	REAR OF CENTER CONSOLE ASSEMBLY

### GROUNDS

Ground	Location / Type
BT1AR	EYELET (PAIR) – RIGHT HAND LEG / ADJACENT TO BATTERY
BT2AR	EYELET (PAIR) – RIGHT HAND LEG / TRUNK, RIGHT REAR
BT3S	EYELET (SINGLE) / TRUNK, LEFT REAR
FC1BL	EYELET (PAIR) – LEFT HAND LEG / TRANSMISSION TUNNEL, RIGHT HAND SIDE
FC2BR	EYELET (PAIR) – RIGHT HAND LEG / RIGHT HAND ‘A’ POST
FC3BL	EYELET (PAIR) – LEFT HAND LEG / TRANSMISSION TUNNEL, LEFT HAND SIDE
FC4BR	EYELET (PAIR) – RIGHT HAND LEG / LEFT HAND ‘A’ POST
RH1S	EYELET (SINGLE) / RIGHT HAND REAR QUARTER

FOR CONTROL MODULE PIN OUT INFORMATION, UNFOLD PAGE TO LEFT.

Refer to the front of this book for detailed information and illustrations regarding the location and identification of harnesses, relays, grounds, control modules and control module pins.

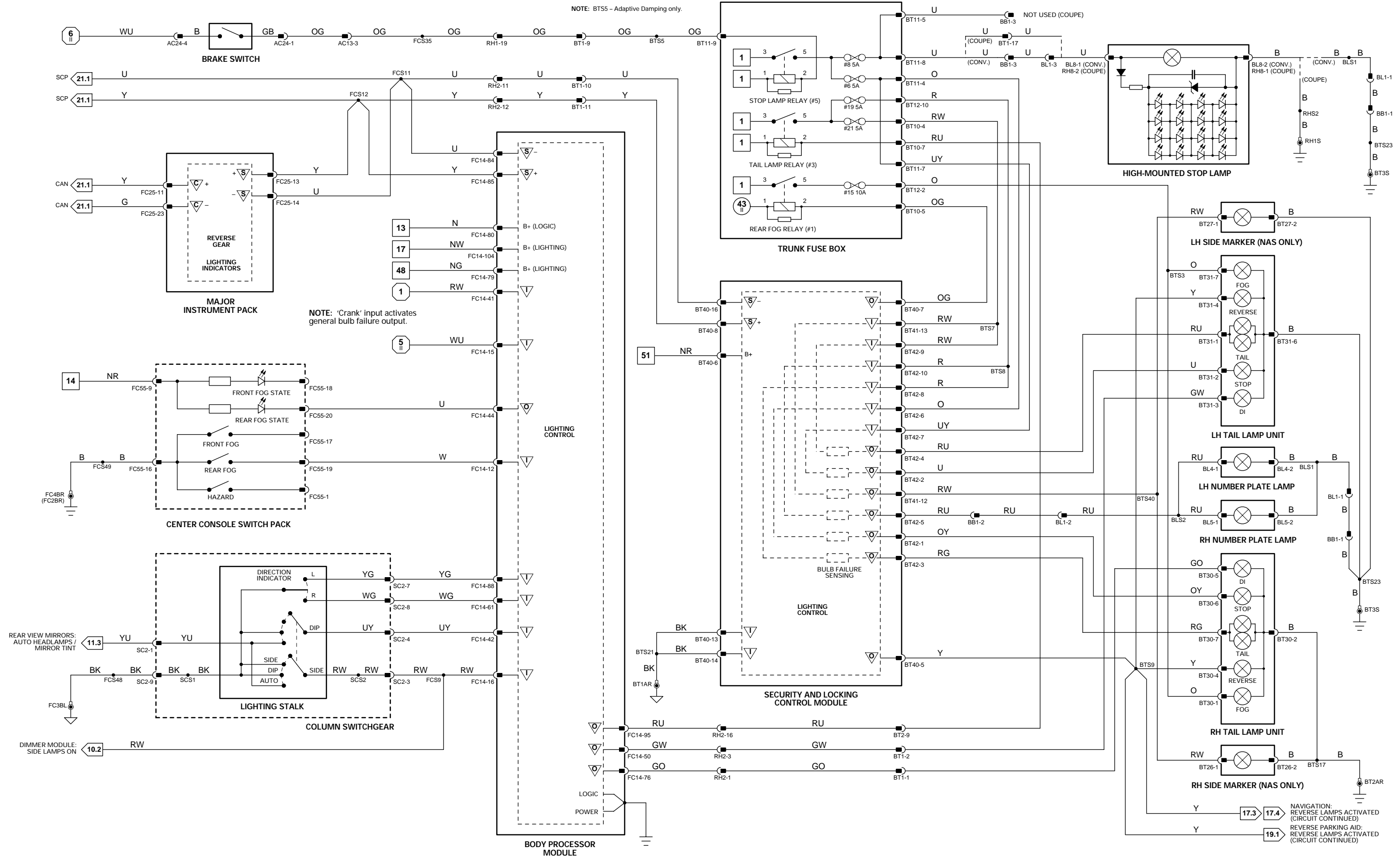

NAVIGATION:  
REVERSE LAMPS ACTIVATED  
(CIRCUIT CONTINUED)

REVERSE PARKING AID:  
REVERSE LAMPS ACTIVATED  
(CIRCUIT CONTINUED)

**Fig. 09.3**

**COMPONENTS**

<b>Component</b>	<b>Connector / Type / Color</b>	<b>Location / Access</b>
HEADLAMP LEVELING ACTUATOR – LH	LF34 / 3-WAY REINSHAGEN / BLACK	HEADLAMP ASSEMBLY / REAR
HEADLAMP LEVELING ACTUATOR – RH	LF24 / 3-WAY REINSHAGEN / BLACK	HEADLAMP ASSEMBLY / REAR
LEVELING SWITCH (CENTER CONSOLE SWITCH PACK)	FC55 / 20-WAY FORD IDC / BLACK	CENTER CONSOLE SWITCH PACK

**HARNESS-TO-HARNESS CONNECTORS**

<b>Connector</b>	<b>Type / Color</b>	<b>Location / Access</b>
LF60	20-WAY MULTILOCK 070 / WHITE	LEFT HAND 'A' POST CONNECTOR MOUNTING BRACKET / 'A' POST TRIM

**GROUNDS**

<b>Ground</b>	<b>Location / Type</b>
FC3BR	EYELET (PAIR) – RIGHT HAND LEG / TRANSMISSION TUNNEL, LEFT HAND SIDE
LF1AL	EYELET (PAIR) – LEFT HAND LEG / RIGHT HAND HEADLAMP
LF2BR	EYELET (PAIR) – RIGHT HAND LEG / ENGINE COMPARTMENT, FORWARD OF LEFT HAND HOOD CATCH

Refer to the front of this book for detailed information and illustrations regarding the location and identification of harnesses, relays, grounds, control modules and control module pins.

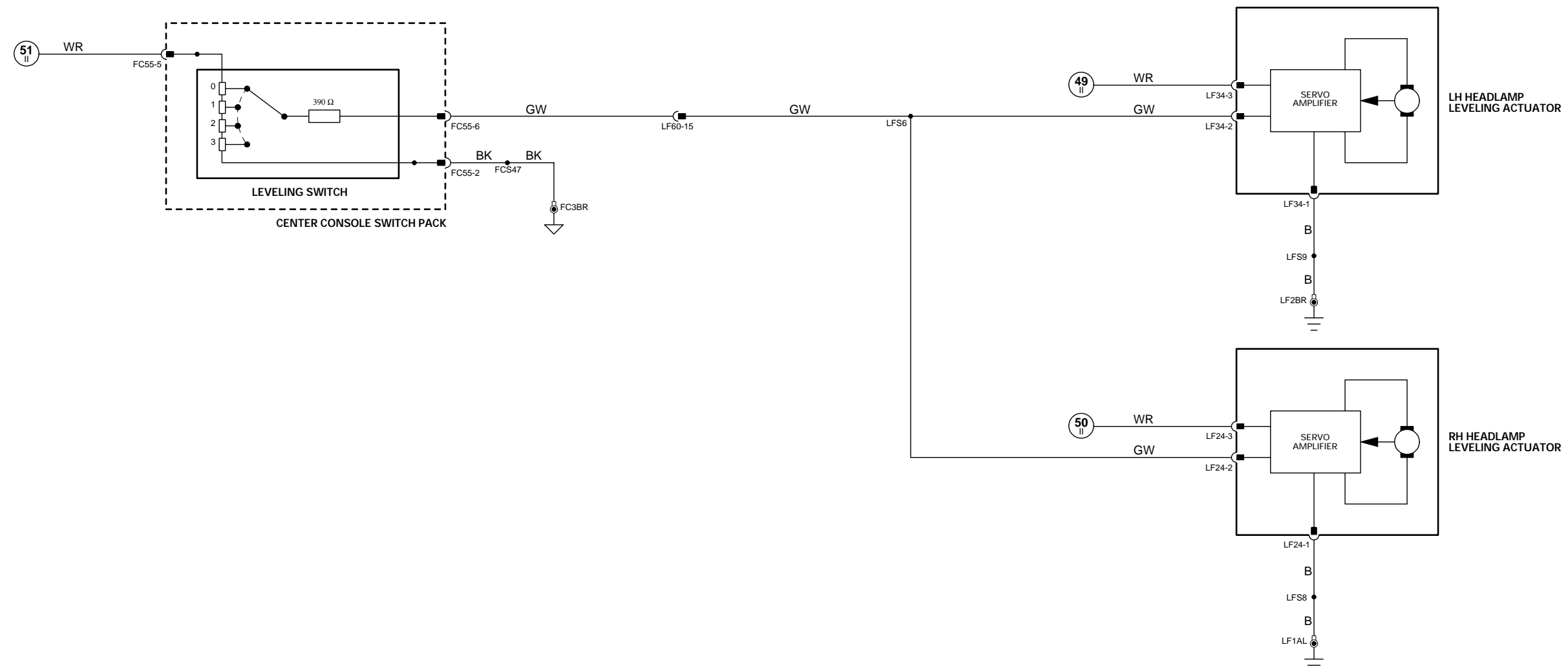

## CONTROL MODULE PIN OUT INFORMATION

### DRIVER DOOR CONTROL MODULE

Pin	Description	Active	Inactive
I DD10-1	BATTERY POWER SUPPLY	B+	B+
I DD10-8	LOGIC GROUND	GROUND	GROUND
S DD10-9	SCP NETWORK	2 – 1600 Hz	
O DD10-14	DRIVER DOOR PUDDLE LAMP SUPPLY	B+	GROUND
S DD10-16	SCP NETWORK	2 – 1600 Hz	
I DD10-17	POWER GROUND	GROUND	GROUND
I DD11-4	DRIVER DOOR LOCK BARREL UNLOCK REQUEST	B+ (MOMENTARY)	GROUND
I DD11-12	DRIVER DOOR LOCK BARREL LOCK REQUEST	B+ (MOMENTARY)	GROUND
I DD11-20	DRIVER DOOR SWITCH	GROUND (DOOR OPEN)	B+

### PASSENGER DOOR CONTROL MODULE

Pin	Description	Active	Inactive
I DP10-1	BATTERY POWER SUPPLY	B+	B+
I DP10-8	LOGIC GROUND	GROUND	GROUND
S DP10-9	SCP NETWORK	2 – 1600 Hz	
O DP10-14	PASSENGER DOOR PUDDLE LAMP SUPPLY	B+ (LIGHT ON)	GROUND
S DP10-16	SCP NETWORK	2 – 1600 Hz	
I DP10-17	POWER GROUND	GROUND	GROUND
I DP11-20	PASSENGER DOOR SWITCH	GROUND (DOOR OPEN)	B+

### BODY PROCESSOR MODULE

Pin	Description	Active	Inactive
I FC14-15	IGNITION SWITCHED GROUND SUPPLY	GROUND	
O FC14-24	FOOTWELL / INTERIOR LAMP SUPPLY	B+	GROUND
I FC14-32	IGNITION SWITCHED GROUND SUPPLY	GROUND	GROUND
I FC14-41	IGNITION GROUND SUPPLY	GROUND	
I FC14-67	KEY IN IGNITION	GROUND (KEY IN)	B+
O FC14-74	INTERIOR LAMP FADE 2 OUTPUT	B+ (FADES TO 0 V)	
I FC14-80	BATTERY POWER SUPPLY (LOGIC)	B+	B+
S FC14-84	SCP NETWORK	2 – 1600 Hz	
S FC14-85	SCP NETWORK	2 – 1600 Hz	
O FC14-101	TRUNK / GLOVE BOX / VANITY LAMP POWER SUPPLY	B+	GROUND
I FC14-104	LIGHTING / MOTORS BATTERY POWER SUPPLY	B+	B+

**NOTE:** Refer to the Appendix at the rear of this book for CAN and SCP Network Messages.

The following abbreviations are used to represent values for Control Module Pin-Out data

I	Input	SG	Sensor Ground	S	SCP Network	V	Voltage (DC)
O	Output	A	ACP Network	D	Serial and Encoded Data	Hz	Frequency
SS	Sensor Supply V	C	CAN (Network)	B+	Battery Voltage	kHz	Frequency x 1000

**CAUTION:** The information on this data page is furnished to aid the user in understanding circuit operation. THIS INFORMATION SHOULD BE USED FOR REFERENCE ONLY.

**NOTE:** The values listed are approximately those that can be expected at the control module connector pins with all circuit connections made and all components connected and fitted. “Active” means a load is applied or a switch is ON; “Inactive” means a load is not applied or a switch is OFF.

**Fig. 10.1**

### COMPONENTS

Component	Connector / Type / Color	Location / Access
BODY PROCESSOR MODULE	FC14 / 104-WAY AMP EEEEC / GREY	PASSENGER SIDE FASCIA / AIRBAG BRACKET
DIODE (BT29) – TRUNK SWITCH	BT29 / DIODE	TRUNK / ADJACENT TO BATTERY
DOOR CONTROL MODULE – DRIVER	DD10 / 22-WAY FORD 2.8 TIMER / BLUE DD11 / 22-WAY FORD 2.8 TIMER / BLACK	DRIVER DOOR / DOOR CASING
DOOR CONTROL MODULE – PASSENGER	DP10 / 22-WAY FORD 2.8 TIMER / BLUE DP11 / 22-WAY FORD 2.8 TIMER / BLACK	PASSENGER DOOR / DOOR CASING
DOOR LOCK SWITCHES – DRIVER	DD3 / 13-WAY ECONOSEAL III LC / BLACK	DRIVER DOOR / DOOR CASING
DOOR SWITCH – DRIVER	DD3 / 13-WAY ECONOSEAL III LC / BLACK	DRIVER DOOR / DOOR CASING
DOOR SWITCH – PASSENGER	DP3 / 13-WAY ECONOSEAL III LC / BLACK	PASSENGER DOOR / DOOR CASING
FOOTWELL LAMP – DRIVER	FC31 / 2-WAY AMP JUNIOR POWER TIMER / BLACK	LEFT HAND FOOTWELL
FOOTWELL LAMP – PASSENGER	FC32 / 2-WAY AMP JUNIOR POWER TIMER / BLACK	RIGHT HAND FOOTWELL
GLOVE BOX LAMP	FC33 / 1-WAY LUCAR STRAIGHT / CLEAR FC34 / 1-WAY LUCAR STRAIGHT / CLEAR	GLOVE BOX
IGNITION SWITCH (KEY-IN SWITCH)	FC4 / 8-WAY MULTILOCK 070 / WHITE	STEERING COLUMN
PUDDLE LAMP – DRIVER DOOR	DD14 / 2-WAY AMP JUNIOR POWER TIMER / BLACK	DRIVER DOOR
PUDDLE LAMP – PASSENGER DOOR	DP14 / 2-WAY AMP JUNIOR POWER TIMER / BLACK	PASSENGER DOOR
REAR INTERIOR LAMP (COUPE ONLY)	RH3 / 2-WAY AMP JUNIOR POWER TIMER / WHITE	REAR CENTER OF HEAD LINING
ROOF CONSOLE	RF10 / 6-WAY MULTILOCK 070 / GREY	INTERIOR ROOF
TRUNK LAMP – LH	BT56 / 2-WAY AMP JUNIOR POWER TIMER / WHITE	TRUNK / LEFT HAND SIDE
TRUNK LAMP – RH	BT59 / 2-WAY AMP JUNIOR POWER TIMER / WHITE	TRUNK / RIGHT HAND SIDE
TRUNK SWITCH	BT46 / 2-WAY AUGAT 1.6 / BLACK	TRUNK
VANITY LAMP – LH	RF8 / 3-WAY MULTILOCK 070 / YELLOW	SUN VISOR
VANITY LAMP – RH	RF7 / 3-WAY MULTILOCK 070 / YELLOW	SUN VISOR

### HARNESSTO-HARNESSTO CONNECTORS

Connector	Type / Color	Location / Access
BT1	20-WAY MULTILOCK 070 / WHITE	TRUNK / ABOVE RIGHT HAND REAR WHEEL ARCH
DD1	23-WAY AMP – FORD / BLACK	DRIVER SIDE ‘A’ POST MOUNTING BRACKET / ‘A’ POST TRIM
DP1	23-WAY AMP – FORD / BLACK	PASSENGER SIDE ‘A’ POST / ‘A’ POST TRIM
RF1	24-WAY CONNECTOR / BLACK	RIGHT HAND ‘A’ POST CONNECTOR MOUNTING BRACKET / ‘A’ POST TRIM
RF5	8-WAY MULTILOCK 070 / WHITE	LOWER RH ‘A’ POST / ‘A’ POST TRIM
RH2	20-WAY MULTILOCK 070 / WHITE	REAR OF CENTER CONSOLE ASSEMBLY

### GROUNDS

Ground	Location / Type
BT1AR	EYELET (PAIR) – RIGHT HAND LEG / ADJACENT TO BATTERY
FC2AL	EYELET (PAIR) – LEFT HAND LEG / RIGHT HAND ‘A’ POST
FC2AR	EYELET (PAIR) – RIGHT HAND LEG / RIGHT HAND ‘A’ POST
FC2BL	EYELET (PAIR) – LEFT HAND LEG / RIGHT HAND ‘A’ POST
FC2BR	EYELET (PAIR) – RIGHT HAND LEG / RIGHT HAND ‘A’ POST
FC3BL	EYELET (PAIR) – LEFT HAND LEG / TRANSMISSION TUNNEL, LEFT HAND SIDE
FC3BR	EYELET (PAIR) – RIGHT HAND LEG / TRANSMISSION TUNNEL, LEFT HAND SIDE
FC4AL	EYELET (PAIR) – LEFT HAND LEG / LEFT HAND ‘A’ POST
FC4AR	EYELET (PAIR) – RIGHT HAND LEG / LEFT HAND ‘A’ POST
FC4BL	EYELET (PAIR) – LEFT HAND LEG / LEFT HAND ‘A’ POST
FC4BR	EYELET (PAIR) – RIGHT HAND LEG / LEFT HAND ‘A’ POST
RH1S	EYELET (SINGLE) / RIGHT HAND REAR QUARTER

FOR CONTROL MODULE PIN OUT INFORMATION, UNFOLD PAGE TO LEFT.

Refer to the front of this book for detailed information and illustrations regarding the location and identification of harnesses, relays, grounds, control modules and control module pins.

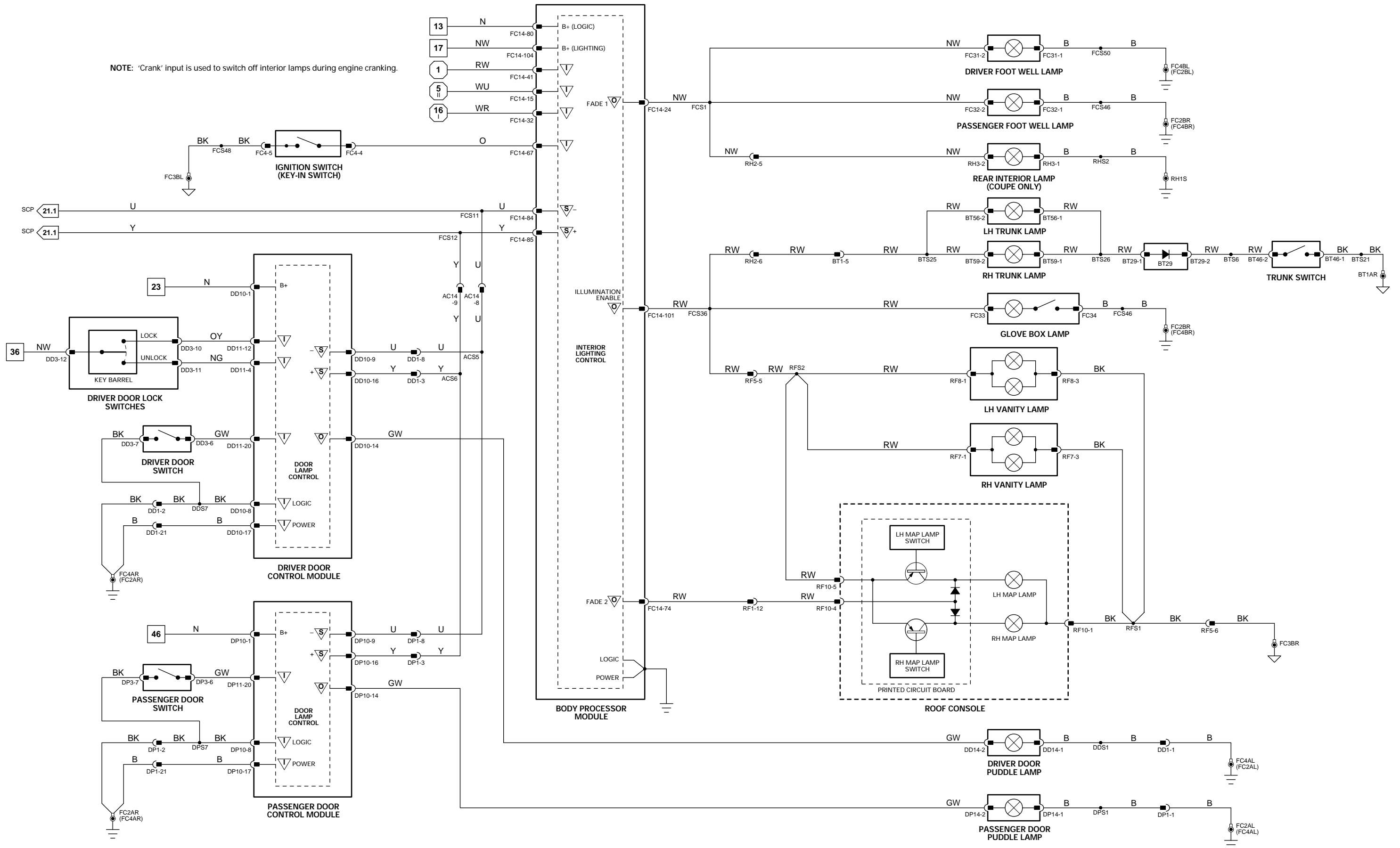

**CONTROL MODULE PIN OUT INFORMATION**

**DIMMER MODULE**

Pin	Description	Active	Inactive
0	FC23-1 MAJOR INSTRUMENT PACK ILLUMINATION BULB SUPPLY	B+ (LIGHTS ON)	GROUND
0	FC23-2 MAJOR INSTRUMENT PACK ILLUMINATION BULB SUPPLY	B+ (LIGHTS ON)	GROUND
I	FC23-3 IGNITION SWITCHED GROUND SUPPLY	GROUND	
I	FC23-4 SIDE LAMPS ON REQUEST	GROUND	
I	FC23-5 DIMMER POTENTIOMETER FEEDBACK VOLTAGE	1.3 V = DIM; 4 V = BRIGHT	
0	FC23-6 DIMMER POTENTIOMETER REFERENCE GROUND	GROUND	GROUND
0	FC23-7 GENERAL ILLUMINATION BULB SUPPLY	B+ (LIGHTS ON)	GROUND
0	FC23-8 GENERAL ILLUMINATION BULB SUPPLY	B+ (LIGHTS ON)	GROUND
I	FC23-9 GROUND SUPPLY	GROUND	GROUND
I	FC23-10 BATTERY POWER SUPPLY	B+	B+
I	FC23-11 BATTERY POWER SUPPLY	B+	B+
0	FC23-12 DIMMER POTENTIOMETER REFERENCE VOLTAGE	4 V	0 V

**Fig. 10.2**

**COMPONENTS**

Component	Connector / Type / Color	Location / Access
AIR CONDITIONING CONTROL PANEL	FC43 / 12-WAY MULTILOCK 040 / BLUE	CENTER CONSOLE
CENTER CONSOLE SWITCH PACK	FC55 / 20-WAY FORD IDC / BLACK	CENTER CONSOLE
CIGAR LIGHTER	FC42 / 2-WAY AMP / METALLIC FC59 / LUCAR POSILOCK / BLACK	FORWARD OF GEAR SELECTOR
CONVERTIBLE TOP SWITCH	FC62 / 10-WAY AMP MQL / BLACK	FORWARD OF GEAR SELECTOR
SPEED CONTROL ON / OFF SWITCH	FC63 / 10-WAY AMP MQL / NATURAL	REARWARD OF GEAR SELECTOR
DIMMER CONTROL (COLUMN SWITCHGEAR)	SC11 / 6-WAY MULTILOCK 070 / WHITE	STEERING COLUMN COWL
DIMMER MODULE	FC23 / 12-WAY MULTILOCK 040 / BLACK	ADJACENT TO RIGHT HAND FASCIA FUSE BOX
GEAR SELECTOR ILLUMINATION MODULE	FC88 / 10-WAY MULTILOCK 070 / WHITE	FRONT OF GEAR SELECTOR ASSEMBLY
LIGHTING STALK (COLUMN SWITCHGEAR)	SC2 / 10-WAY MULTILOCK 070 / YELLOW	STEERING COLUMN
MAJOR INSTRUMENT PACK	FC25 / 26-WAY AMP MICRO QUAD LOCK / BLACK FC26 / 26-WAY AMP MICRO QUAD LOCK / YELLOW	FASCIA
MINOR INSTRUMENT PACK	FC79 / 20-WAY MULTILOCK 040 / BLACK	FASCIA
MODE SWITCH (TRANSMISSION)	FC35 / 10-WAY AMP MQL / BLACK	REARWARD OF GEAR SELECTOR
NAVIGATION CONTROL MODULE	IC7 / 8-WAY ALPINE / BLACK IC22 / 16-WAY AMP ML42 / BLACK IC23 / 24-WAY AMP ML42 / BLACK FC97 / 12-WAY AMP ML42 / BLACK FC98 / 16-WAY AMP ML42 / BLACK	TRUNK / RIGHT HAND SIDE
NAVIGATION DISPLAY	IC8 / 8-WAY ALPINE / BLACK	BEHIND NAVIGATION DISPLAY
RADIO / CASSETTE HEAD UNIT	IC19 / 12-WAY MULTILOCK 070 / WHITE IC20 / 26-WAY MQS / YELLOW	CENTER CONSOLE
ROOF CONSOLE	RF10 / 6-WAY MULTILOCK 070 / GREY	INTERIOR ROOF
SWITCH PACK – DRIVER DOOR	DD17 / 20-WAY MULTILOCK 040 / BLACK	DRIVER DOOR
SWITCH PACK – DRIVER DOOR MEMORY	DD5 / 10-WAY AMP MQL / BLACK	DRIVER DOOR
SWITCH PACK – PASSENGER DOOR	DP17 / 8-WAY MULTILOCK 040 / BLACK	PASSENGER DOOR
TRIP COMPUTER SWITCH PACK	FC27 / 10-WAY AMP MQL / BLACK	FASCIA / DRIVER SIDE
TRUNK AND FUEL FILL RELEASE SWITCH	FC41 / 10-WAY AMP MQL / NATURAL	FASCIA / DRIVER SIDE
VALET SWITCH	FC67 / 10-WAY AMP MQL / BLACK	DRIVER KNEE BOLSTER

**HARNESS-TO-HARNESS CONNECTORS**

Connector	Type / Color	Location / Access
AC15	20-WAY MULTILOCK 070 / GREY	FASCIA BOTTOM CONNECTOR MOUNTING BRACKET / RIGHT HAND SIDE
DD1	23-WAY AMP – FORD / BLACK	DRIVER SIDE 'A' POST MOUNTING BRACKET / 'A' POST TRIM
DP1	23-WAY AMP – FORD / BLACK	PASSENGER SIDE 'A' POST / 'A' POST TRIM
IC1	20-WAY MULTILOCK 070 / YELLOW	BELOW CENTER CONSOLE GLOVE BOX
RF1	24-WAY CONNECTOR / BLACK	RIGHT HAND 'A' POST CONNECTOR MOUNTING BRACKET / 'A' POST TRIM
SC3	12-WAY MULTILOCK 070 / GREY	RIGHT HAND SIDE OF STEERING COLUMN

**GROUND**

Ground	Location / Type
CE2	EYELET (SINGLE) / ABOVE RIGHT HAND SIDE OF TRANSMISSION TUNNEL
FC2AL	EYELET (PAIR) – LEFT HAND LEG / RIGHT HAND 'A' POST
FC2BL	EYELET (PAIR) – LEFT HAND LEG / RIGHT HAND 'A' POST
FC2BR	EYELET (PAIR) – RIGHT HAND LEG / RIGHT HAND 'A' POST
FC3BL	EYELET (PAIR) – LEFT HAND LEG / TRANSMISSION TUNNEL, LEFT HAND SIDE
FC3BR	EYELET (PAIR) – RIGHT HAND LEG / TRANSMISSION TUNNEL, LEFT HAND SIDE
FC4AL	EYELET (PAIR) – LEFT HAND LEG / LEFT HAND 'A' POST
FC4BL	EYELET (PAIR) – LEFT HAND LEG / LEFT HAND 'A' POST
FC4BR	EYELET (PAIR) – RIGHT HAND LEG / LEFT HAND 'A' POST

FOR CONTROL MODULE PIN OUT INFORMATION, UNFOLD PAGE TO LEFT.

The following abbreviations are used to represent values for Control Module Pin-Out data

I	Input	SG	Sensor Ground	S	SCP Network	V	Voltage (DC)
O	Output	A	ACP Network	D	Serial and Encoded Data	Hz	Frequency
SS	Sensor Supply V	C	CAN (Network)	B+	Battery Voltage	kHz	Frequency x 1000

CAUTION: The information on this data page is furnished to aid the user in understanding circuit operation. THIS INFORMATION SHOULD BE USED FOR REFERENCE ONLY.

NOTE: The values listed are approximately those that can be expected at the control module connector pins with all circuit connections made and all components connected and fitted. "Active" means a load is applied or a switch is ON; "Inactive" means a load is not applied or a switch is OFF.

Refer to the front of this book for detailed information and illustrations regarding the location and identification of harnesses, relays, grounds, control modules and control module pins.



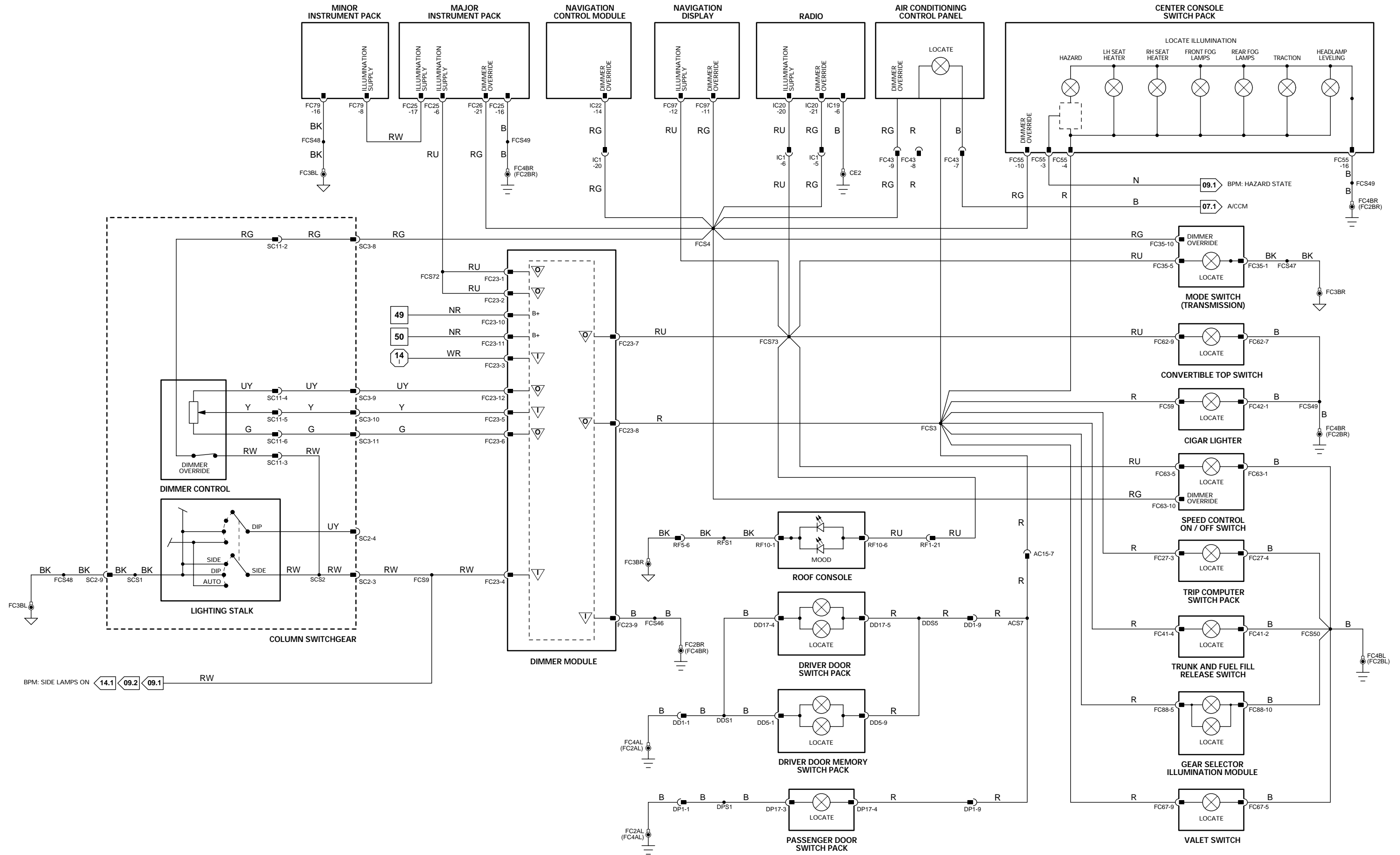

**CONTROL MODULE PIN OUT INFORMATION**

**BODY PROCESSOR MODULE**

Pin	Description	Active	Inactive
I	FC14-11	AUTO TILT REQUEST	GROUND
I	FC14-15	IGNITION SWITCHED GROUND SUPPLY	GROUND
I	FC14-25	COLUMN MOTOR GROUND SUPPLY	GROUND
I	FC14-32	IGNITION SWITCHED GROUND SUPPLY	GROUND
O	FC14-40	COLUMN MOTOR POTENTIOMETER REFERENCE VOLTAGE	5 V
I	FC14-41	IGNITION GROUND SUPPLY	GROUND
O	FC14-52	COLUMN REACH MOTOR SUPPLY	B+
I	FC14-58	NOT-IN-PARK	GROUND (R,N,D,4,3,2)
I	FC14-66	COLUMN REACH MOTOR POTENTIOMETER FEEDBACK	0.5 V (OUT); 4 V (IN)
I	FC14-67	KEY IN IGNITION	GROUND (KEY IN)
O	FC14-78	COLUMN REACH MOTOR SUPPLY	B+
I	FC14-80	BATTERY POWER SUPPLY (LOGIC)	B+
S	FC14-84	SCP NETWORK	2 – 1600 Hz
S	FC14-85	SCP NETWORK	2 – 1600 Hz
I	FC14-87	COLUMN MOVEMENT REQUEST	UP = 10.1 V, DOWN = 12.1 V, RETRACT = 8.5 V, EXTEND = 6.8 V
O	FC14-90	COLUMN TILT MOTOR POTENTIOMETER REFERENCE GROUND	GROUND
O	FC14-91	COLUMN REACH MOTOR POTENTIOMETER REFERENCE GROUND	GROUND
I	FC14-93	COLUMN TILT MOTOR POTENTIOMETER FEEDBACK	UP = 4 V, DOWN = 0.5 V
O	FC14-99	COLUMN TILT MOTOR SUPPLY	B+
O	FC14-100	COLUMN TILT MOTOR SUPPLY	B+
I	FC14-102	COLUMN MOVEMENT MOTORS BATTERY POWER SUPPLY	B+

**DRIVER DOOR CONTROL MODULE**

Pin	Description	Active	Inactive
I	DD10-1	BATTERY POWER SUPPLY	B+
I	DD10-8	LOGIC GROUND	GROUND
S	DD10-9	SCP NETWORK	2 – 1600 Hz
S	DD10-16	SCP NETWORK	2 – 1600 Hz
I	DD10-17	POWER GROUND	GROUND
O	DD11-2	SEAT MEMORY STATUS LED	GROUND (LED ON)
I	DD11-6	MEMORY SET REQUEST	B+
I	DD11-20	DRIVER DOOR SWITCH	GROUND (DOOR OPEN)
I	DD11-21	MEMORY 1 RECALL REQUEST	B+ (MOMENTARY)
I	DD11-22	MEMORY 2 RECALL REQUEST	B+ (MOMENTARY)

**NOTE:** Refer to the Appendix at the rear of this book for CAN and SCP Network Messages.

The following abbreviations are used to represent values for Control Module Pin-Out data

I	Input	SG	Sensor Ground	S	SCP Network	V	Voltage (DC)
O	Output	A	ACP Network	D	Serial and Encoded Data	Hz	Frequency
SS	Sensor Supply V	C	CAN (Network)	B+	Battery Voltage	kHz	Frequency x 1000

**CAUTION:** The information on this data page is furnished to aid the user in understanding circuit operation. THIS INFORMATION SHOULD BE USED FOR REFERENCE ONLY.

**NOTE:** The values listed are approximately those that can be expected at the control module connector pins with all circuit connections made and all components connected and fitted. "Active" means a load is applied or a switch is ON; "Inactive" means a load is not applied or a switch is OFF.

**Fig. 11.1**

**COMPONENTS**

Component	Connector / Type / Color	Location / Access
AUTO TILT SWITCH (COLUMN SWITCHGEAR)	SC9 / 8-WAY GROTE AND HARTMAN MDK / BLACK	STEERING COLUMN / LEFT HAND SIDE
BODY PROCESSOR MODULE	FC14 / 104-WAY AMP EEEC / GREY	PASSENGER SIDE FASCIA / AIRBAG BRACKET
COLUMN JOY STICK (COLUMN SWITCHGEAR)	SC9 / 8-WAY GROTE AND HARTMAN MDK / BLACK	STEERING COLUMN / LEFT HAND SIDE
DOOR CONTROL MODULE – DRIVER	DD10 / 22-WAY FORD 2.8 TIMER / BLUE DD11 / 22-WAY FORD 2.8 TIMER / BLACK	DRIVER DOOR / DOOR CASING
DOOR SWITCH – DRIVER	DD3 / 13-WAY ECONOSEAL III LC / BLACK	DRIVER DOOR / DOOR CASING
IGNITION SWITCH (KEY-IN SWITCH)	FC4 / 8-WAY MULTILOCK 070 / WHITE	STEERING COLUMN
NOT-IN-PARK MICROSWITCH	FC87 / 3-WAY MULTILOCK 070 / WHITE	GEAR SELECTOR ASSEMBLY
STEERING COLUMN MOTORS	FC60 / 6-WAY MULTILOCK 070 / WHITE FC61 / 8-WAY MULTILOCK 070 / YELLOW	STEERING COLUMN
SWITCH PACK – DRIVER DOOR MEMORY	DD5 / 10-WAY AMP MQL / BLACK	DRIVER DOOR

**HARNESS-TO-HARNESS CONNECTORS**

Connector	Type / Color	Location / Access
AC14	14-WAY MULTILOCK 070 / GREY	FASCIA BOTTOM CONNECTOR MOUNTING BRACKET / RIGHT HAND SIDE
DD1	23-WAY AMP – FORD / BLACK	DRIVER SIDE 'A' POST MOUNTING BRACKET/ 'A' POST TRIM
SC2	10-WAY MULTILOCK 070 / YELLOW	ADJACENT TO STEERING COLUMN MOTOR
SC3	12-WAY MULTILOCK 070 / GREY	RIGHT HAND SIDE OF STEERING COLUMN

**GROUND**

Ground	Location / Type
FC2AR	EYELET (PAIR) – RIGHT HAND LEG / RIGHT HAND 'A' POST
FC2BR	EYELET (PAIR) – RIGHT HAND LEG / RIGHT HAND 'A' POST
FC3BL	EYELET (PAIR) – LEFT HAND LEG / TRANSMISSION TUNNEL, LEFT HAND SIDE
FC3BR	EYELET (PAIR) – RIGHT HAND LEG / TRANSMISSION TUNNEL, LEFT HAND SIDE
FC4AR	EYELET (PAIR) – RIGHT HAND LEG / LEFT HAND 'A' POST
FC4BR	EYELET (PAIR) – RIGHT HAND LEG / LEFT HAND 'A' POST

**FOR CONTROL MODULE PIN OUT INFORMATION, UNFOLD PAGE TO LEFT.**

Refer to the front of this book for detailed information and illustrations regarding the location and identification of harnesses, relays, grounds, control modules and control module pins.

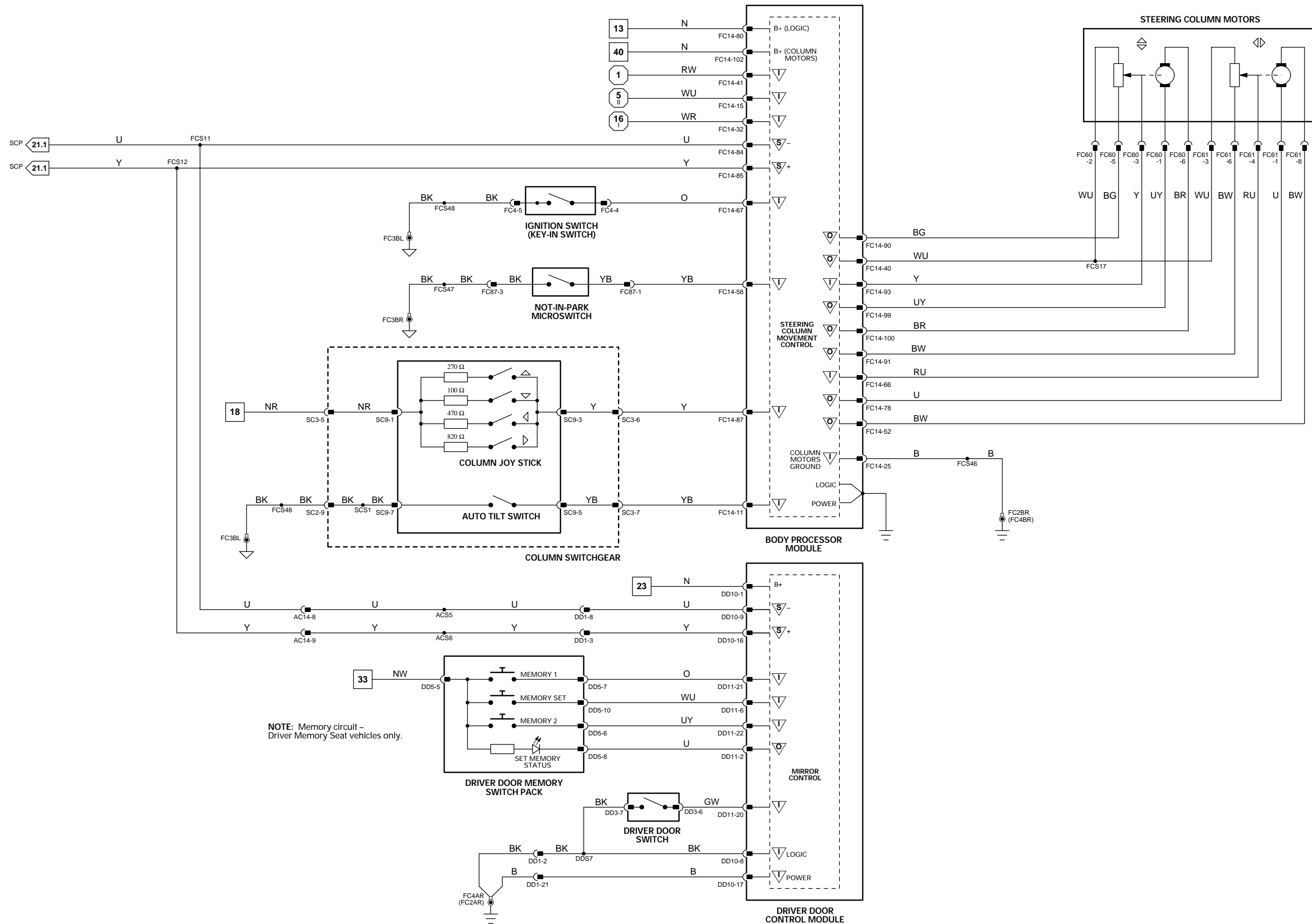

NOTE: Memory circuit - Driver Memory Seat vehicles only.

## CONTROL MODULE PIN OUT INFORMATION

### BODY PROCESSOR MODULE

Pin	Description	Active	Inactive
I FC14-15	IGNITION SWITCHED GROUND SUPPLY	GROUND	
I FC14-32	IGNITION SWITCHED GROUND SUPPLY	GROUND	GROUND
I FC14-41	IGNITION GROUND SUPPLY	GROUND	
I FC14-58	NOT-IN-PARK	GROUND (R,N,D,4,3,2)	B+ (PARK)
I FC14-80	BATTERY POWER SUPPLY (LOGIC)	B+	B+
S FC14-84	SCP NETWORK	2 – 1600 Hz	
S FC14-85	SCP NETWORK	2 – 1600 Hz	

### DRIVER DOOR CONTROL MODULE

Pin	Description	Active	Inactive
I DD10-1	BATTERY POWER SUPPLY	B+	
O DD10-2	DRIVER DOOR MIRROR VERTICAL / HORIZONTAL MOTOR COMMON SUPPLY	B+ = LEFT / DOWN; GROUND = RIGHT / UP	
O DD10-3	DRIVER DOOR MIRROR HORIZONTAL MOVEMENT MOTOR	B+ = RIGHT	GROUND = LEFT
O DD10-4	DRIVER DOOR MIRROR VERTICAL MOVEMENT MOTOR	B+ = UP	GROUND = DOWN
I DD10-8	LOGIC GROUND	GROUND	GROUND
S DD10-9	SCP NETWORK	2 – 1600 Hz	
S DD10-16	SCP NETWORK	2 – 1600 Hz	
I DD10-17	POWER GROUND	GROUND	GROUND
O DD10-20	DRIVER DOOR MIRROR POTENTIOMETER COMMON REFERENCE VOLTAGE	B+	
I DD10-21	DRIVER DOOR MIRROR POTENTIOMETER HORIZONTAL POSITION FEEDBACK	1 V = LEFT; 8 V = RIGHT	
I DD10-22	DRIVER DOOR MIRROR POTENTIOMETER VERTICAL POSITION FEEDBACK	1 V = DOWN; 8 V = UP	
I DD11-1	MIRROR SELECT	B+ = UP / RIGHT	GROUND = DOWN / LEFT
O DD11-2	SEAT MEMORY STATUS LED	GROUND (LED ON)	B+
I DD11-3	RH VERTICAL MOVEMENT REQUEST	B+ = DOWN	GROUND = UP
I DD11-6	MEMORY SET REQUEST	B+	
I DD11-9	RH HORIZONTAL MOVEMENT REQUEST	B+ = LEFT	GROUND = RIGHT
I DD11-10	LH HORIZONTAL MOVEMENT REQUEST	B+ = LEFT	GROUND = RIGHT
I DD11-17	LH VERTICAL MOVEMENT REQUEST	B+ = DOWN	GROUND = UP
I DD11-20	DRIVER DOOR SWITCH	GROUND (DOOR OPEN)	B+
I DD11-21	MEMORY 1 RECALL REQUEST	B+ (MOMENTARY)	GROUND
I DD11-22	MEMORY 2 RECALL REQUEST	B+ (MOMENTARY)	GROUND

### MAJOR INSTRUMENT PACK

Pin	Description	Active	Inactive
C FC25-11	CAN NETWORK	15 – 1500 Hz	
S FC25-13	SCP NETWORK	2 – 1600 Hz	
S FC25-14	SCP NETWORK	2 – 1600 Hz	
C FC25-23	CAN NETWORK	15 – 1500 Hz	

### PASSENGER DOOR CONTROL MODULE

Pin	Description	Active	Inactive
I DP10-1	BATTERY POWER SUPPLY	B+	B+
O DP10-2	PASSENGER DOOR MIRROR VERTICAL / HORIZONTAL MOVEMENT MOTORS COMMON	B+ = LEFT / DOWN	GROUND = RIGHT / UP
O DP10-3	PASSENGER DOOR MIRROR HORIZONTAL MOVEMENT MOTOR	B+ = RIGHT	GROUND
O DP10-4	PASSENGER DOOR MIRROR VERTICAL MOVEMENT MOTOR	B+ = UP	GROUND
I DP10-8	LOGIC GROUND	GROUND	GROUND
S DP10-9	SCP NETWORK	2 – 1600 Hz	
S DP10-16	SCP NETWORK	2 – 1600 Hz	
I DP10-17	POWER GROUND	GROUND	GROUND
O DP10-20	PASSENGER DOOR MIRROR POTENTIOMETER COMMON REFERENCE VOLTAGE	B+	B+
I DP10-21	PASSENGER DOOR MIRROR POTENTIOMETER HORIZONTAL POSITION FEEDBACK VOLTAGE	1 V = LEFT; 8 V = RIGHT	
I DP10-22	PASSENGER DOOR MIRROR POTENTIOMETER VERTICAL POSITION FEEDBACK VOLTAGE	1 V = DOWN; 8 V = UP	

NOTE: Refer to the Appendix at the rear of this book for CAN and SCP Network Messages.

The following abbreviations are used to represent values for Control Module Pin-Out data

I	Input	SG	Sensor Ground	S	SCP Network	V	Voltage (DC)
O	Output	A	ACP Network	D	Serial and Encoded Data	Hz	Frequency
SS	Sensor Supply V	C	CAN (Network)	B+	Battery Voltage	kHz	Frequency x 1000

CAUTION: The information on this data page is furnished to aid the user in understanding circuit operation. THIS INFORMATION SHOULD BE USED FOR REFERENCE ONLY.

NOTE: The values listed are approximately those that can be expected at the control module connector pins with all circuit connections made and all components connected and fitted. "Active" means a load is applied or a switch is ON; "Inactive" means a load is not applied or a switch is OFF.

Fig. 11.2

### COMPONENTS

Component	Connector / Type / Color	Location / Access
BODY PROCESSOR MODULE	FC14 / 104-WAY AMP EEEC / GREY	PASSENGER SIDE FASCIA / AIRBAG BRACKET
DOOR CONTROL MODULE – DRIVER	DD10 / 22-WAY FORD 2.8 TIMER / BLUE DD11 / 22-WAY FORD 2.8 TIMER / BLACK	DRIVER DOOR / DOOR CASING
DOOR CONTROL MODULE – PASSENGER	DP10 / 22-WAY FORD 2.8 TIMER / BLUE DP11 / 22-WAY FORD 2.8 TIMER / BLACK	PASSENGER DOOR / DOOR CASING
DOOR MIRROR MOTORS – DRIVER	MD1 / 8-WAY CONNECTOR / BLUE	BEHIND MIRROR
DOOR MIRROR MOTORS – PASSENGER	MP1 / 8-WAY CONNECTOR / BLUE	BEHIND MIRROR
DOOR SWITCH – DRIVER	DD3 / 13-WAY ECONOSEAL III LC / BLACK	DRIVER DOOR / DOOR CASING
MAJOR INSTRUMENT PACK	FC25 / 26-WAY AMP MICRO QUAD LOCK / BLACK FC26 / 26-WAY AMP MICRO QUAD LOCK / YELLOW DD17 / 20-WAY MULTILOCK 040 / BLACK FC87 / 3-WAY MULTILOCK 070 / WHITE DD5 / 10-WAY AMP MQL / BLACK	FASCIA DRIVER DOOR SWITCH PACK GEAR SELECTOR ASSEMBLY DRIVER DOOR

### HARNESS-TO-HARNESS CONNECTORS

Connector	Type / Color	Location / Access
AC14	14-WAY MULTILOCK 070 / GREY	FASCIA BOTTOM CONNECTOR MOUNTING BRACKET / RIGHT HAND SIDE
DD1	23-WAY AMP – FORD / BLACK	DRIVER SIDE 'A' POST MOUNTING BRACKET / 'A' POST TRIM
DD8	12-WAY MULTILOCK 040 / BLUE	DRIVER DOOR / DOOR CASING
DP1	23-WAY AMP – FORD / BLACK	PASSENGER SIDE 'A' POST / 'A' POST TRIM
DP8	12-WAY MULTILOCK 040 / BLUE	PASSENGER DOOR / DOOR CASING

### GROUNDS

Ground	Location / Type
FC2AR	EYELET (PAIR) – RIGHT HAND LEG / RIGHT HAND 'A' POST
FC3AS	EYELET (SINGLE) / TRANSMISSION TUNNEL, LEFT HAND SIDE
FC3BR	EYELET (PAIR) – RIGHT HAND LEG / TRANSMISSION TUNNEL, LEFT HAND SIDE
FC4AR	EYELET (PAIR) – RIGHT HAND LEG / LEFT HAND 'A' POST

FOR CONTROL MODULE PIN OUT INFORMATION, UNFOLD PAGE TO LEFT.

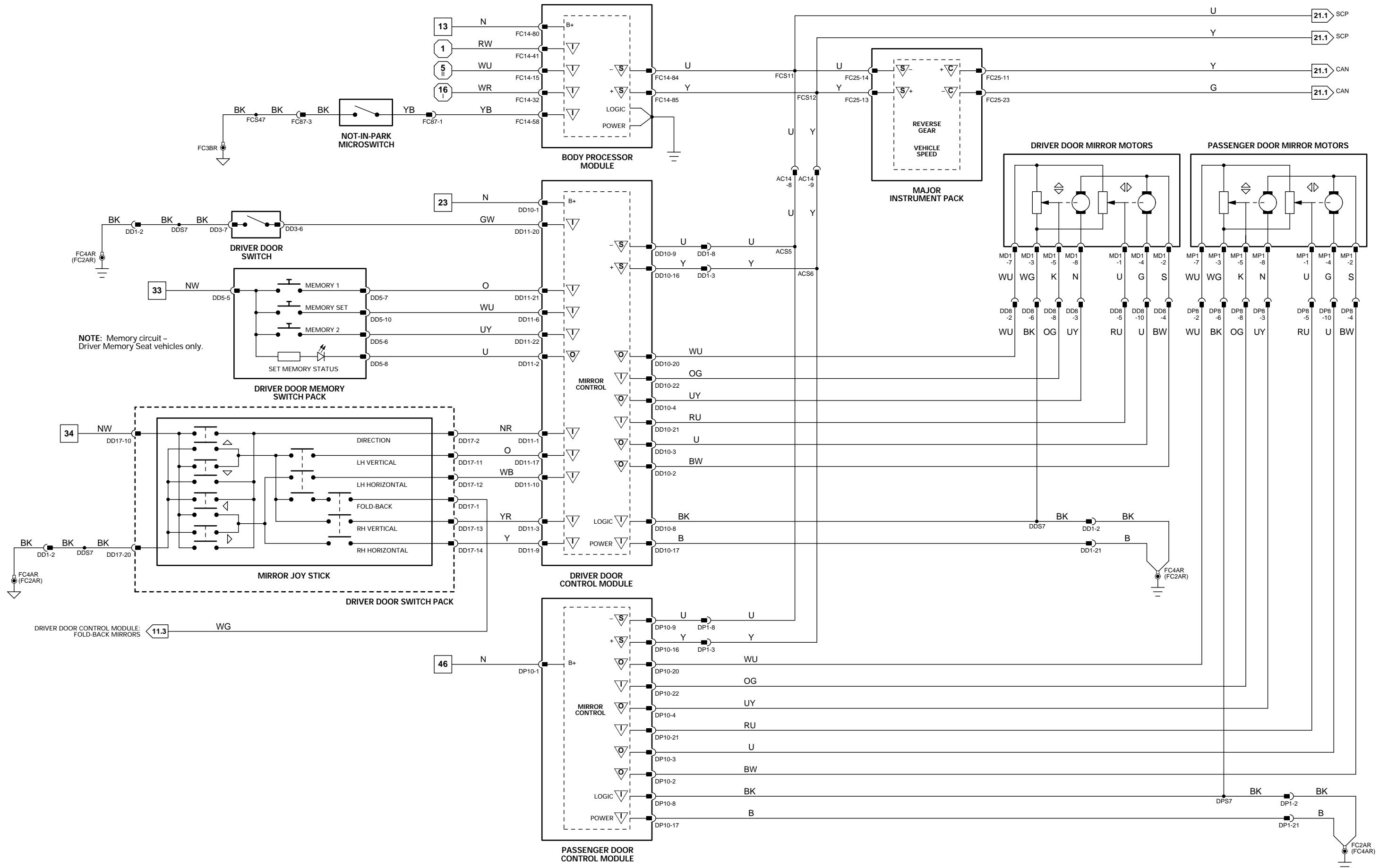

## CONTROL MODULE PIN OUT INFORMATION

### BODY PROCESSOR MODULE

Pin	Description	Active	Inactive
I FC14-15	IGNITION SWITCHED GROUND SUPPLY	GROUND	
I FC14-16	SIDE LAMP REQUEST	GROUND	B+
I FC14-42	DIPPED BEAM REQUEST	GROUND	B+
I FC14-79	BATTERY POWER SUPPLY	B+	B+
I FC14-80	BATTERY POWER SUPPLY (LOGIC)	B+	B+
S FC14-84	SCP NETWORK	2 – 1600 Hz	
S FC14-85	SCP NETWORK	2 – 1600 Hz	

### DRIVER DOOR CONTROL MODULE

Pin	Description	Active	Inactive
I DD10-1	BATTERY POWER SUPPLY	B+	
I DD10-8	LOGIC GROUND	GROUND	B+
S DD10-9	SCP NETWORK	2 – 1600 Hz	GROUND
S DD10-16	SCP NETWORK	2 – 1600 Hz	
I DD11-15	DOOR MIRROR POWER FOLD BACK REQUEST	B+	GROUND

### DRIVER SEAT CONTROL MODULE

Pin	Description	Active	Inactive
O SD3-4	DOOR MIRROR FOLD BACK ACTIVATE	GROUND	B+
I SD5-2	POWER GROUND	GROUND	GROUND
I SD5-5	BATTERY POWER SUPPLY	B+	B+
S SD5-9	SCP NETWORK	2 – 1600 Hz	
S SD5-10	SCP NETWORK	2 – 1600 Hz	

### MAJOR INSTRUMENT PACK

Pin	Description	Active	Inactive
C FC25-11	CAN NETWORK	15 – 1500 Hz	
S FC25-13	SCP NETWORK	2 – 1600 Hz	
S FC25-14	SCP NETWORK	2 – 1600 Hz	
C FC25-23	CAN NETWORK	15 – 1500 Hz	

### PASSENGER SEAT CONTROL MODULE

Pin	Description	Active	Inactive
O SP3-4	DOOR MIRROR FOLD OUT ACTIVATE	GROUND	B+
I SP5-2	POWER GROUND	GROUND	GROUND
I SP5-5	BATTERY POWER SUPPLY	B+	B+
S SP5-9	SCP NETWORK	2 – 1600 Hz	
S SP5-10	SCP NETWORK	2 – 1600 Hz	

### SECURITY AND LOCKING CONTROL MODULE

Pin	Description	Active	Inactive
O BT40-5	REVERSE LAMP SUPPLY	B+	
I BT40-6	BATTERY POWER SUPPLY	B+	
S BT40-8	SCP NETWORK	2 – 1600 Hz	
I BT40-13	GROUND	GROUND	GROUND
I BT40-14	GROUND	GROUND	GROUND
S BT40-16	SCP NETWORK	2 – 1600 Hz	

**NOTE:** Refer to the Appendix at the rear of this book for CAN and SCP Network Messages.

The following abbreviations are used to represent values for Control Module Pin-Out data

I	Input	SG	Sensor Ground	S	SCP Network	V	Voltage (DC)
O	Output	A	ACP Network	D	Serial and Encoded Data	Hz	Frequency
SS	Sensor Supply V	C	CAN (Network)	B+	Battery Voltage	kHz	Frequency x 1000

**CAUTION:** The information on this data page is furnished to aid the user in understanding circuit operation. THIS INFORMATION SHOULD BE USED FOR REFERENCE ONLY.

**NOTE:** The values listed are approximately those that can be expected at the control module connector pins with all circuit connections made and all components connected and fitted. “Active” means a load is applied or a switch is ON; “Inactive” means a load is not applied or a switch is OFF.

**Fig. 11.3**

## COMPONENTS

Component	Connector / Type / Color	Location / Access
BODY PROCESSOR MODULE	FC14 / 104-WAY AMP EEEC / GREY	PASSENGER SIDE FASCIA / AIRBAG BRACKET
DOOR CONTROL MODULE – DRIVER	DD10 / 22-WAY FORD 2.8 TIMER / BLUE DD11 / 22-WAY FORD 2.8 TIMER / BLACK DD8 / 12-WAY MULTILOCK 040 / BLACK	DRIVER DOOR / DOOR CASING
DOOR MIRROR – DRIVER	DP8 / 12-WAY MULTILOCK 040 / BLACK	DRIVER DOOR
DOOR MIRROR – PASSENGER	DP8 / 12-WAY MULTILOCK 040 / BLACK	PASSENGER DOOR
INTERIOR REAR VIEW MIRROR	RF2 / 6-WAY MULTILOCK 070 / YELLOW	WINDSHIELD / FORWARD OF ROOF CONSOLE
LIGHTING STALK (COLUMN SWITCHGEAR)	SC2 / 10-WAY MULTILOCK 070 / YELLOW	STEERING COLUMN
MAJOR INSTRUMENT PACK	FC25 / 26-WAY AMP MICRO QUAD LOCK / BLACK FC26 / 26-WAY AMP MICRO QUAD LOCK / YELLOW DD17 / 20-WAY MULTILOCK 040 / BLACK	FASCIA
MIRROR JOY STICK (DRIVER DOOR SWITCH PACK)	SD3 / 16-WAY FORD 2.8 TIMER / BLACK	DRIVER DOOR SWITCH PACK
SEAT CONTROL MODULE – DRIVER	SD4 / 26-WAY FORD IDC / BLACK SD5 / 10-WAY FORD 2.8 TIMER / BLACK	BELOW SEAT CUSHION
SEAT CONTROL MODULE – PASSENGER	SP3 / 16-WAY FORD 2.8 TIMER / BLACK SP5 / 10-WAY FORD 2.8 TIMER / BLACK	BELOW SEAT CUSHION
SECURITY AND LOCKING CONTROL MODULE	BT40 / 16-WAY FORD 2.8 TIMER / BLACK BT41 / 26-WAY FORD IDC / BLACK BT42 / 10-WAY FORD 2.8 TIMER / BLACK RH20 / COAXIAL CONNECTOR	TRUNK / ELECTRICAL CARRIER

## HARNESS-TO-HARNESS CONNECTORS

Connector	Type / Color	Location / Access
AC13	20-WAY MULTILOCK 070 / YELLOW	FASCIA BOTTOM CONNECTOR MOUNTING BRACKET / RIGHT HAND SIDE
AC14	14-WAY MULTILOCK 070 / GREY	FASCIA BOTTOM CONNECTOR MOUNTING BRACKET / RIGHT HAND SIDE
AC16	6-WAY MULTILOCK 070 / YELLOW	LEFT HAND 'A' POST CONNECTOR MOUNTING BRACKET / 'A' POST TRIM
BT1	20-WAY MULTILOCK 070 / WHITE	TRUNK / ABOVE RIGHT HAND REAR WHEEL ARCH
DD1	23-WAY AMP – FORD / BLACK	DRIVER SIDE 'A' POST MOUNTING BRACKET / 'A' POST TRIM
DP1	23-WAY AMP – FORD / BLACK	PASSENGER SIDE 'A' POST / 'A' POST TRIM
RF1	24-WAY CONNECTOR / BLACK	RIGHT HAND 'A' POST CONNECTOR MOUNTING BRACKET / 'A' POST TRIM
RF5	8-WAY MULTILOCK 070 / WHITE	LOWER RH 'A' POST / 'A' POST TRIM
RH2	20-WAY MULTILOCK 070 / WHITE	REAR OF CENTER CONSOLE ASSEMBLY
RH12	18-WAY MULTILOCK 070 / YELLOW	REAR OF CENTER CONSOLE ASSEMBLY
SD1	14-WAY MULTILOCK 070 / YELLOW	BELOW DRIVER SEAT
SP1	14-WAY MULTILOCK 070 / YELLOW	BELOW PASSENGER SEAT

## GROUNDINGS

Ground	Location / Type
BT1AR	EYELET (PAIR) – RIGHT HAND LEG / ADJACENT TO BATTERY
FC2AR	EYELET (PAIR) – RIGHT HAND LEG / RIGHT HAND 'A' POST
FC3BL	EYELET (PAIR) – LEFT HAND LEG / TRANSMISSION TUNNEL, LEFT HAND SIDE
FC3BR	EYELET (PAIR) – RIGHT HAND LEG / TRANSMISSION TUNNEL, LEFT HAND SIDE
FC4AR	EYELET (PAIR) – RIGHT HAND LEG / LEFT HAND 'A' POST
FC5L	EYELET (PAIR) – LEFT HAND LEG / RIGHT HAND SEAT
FC5S	EYELET (SINGLE) / RIGHT HAND SEAT
FC6L	EYELET (PAIR) – LEFT HAND LEG / LEFT HAND SEAT
FC6S	EYELET (SINGLE) / LEFT HAND SEAT

FOR CONTROL MODULE PIN OUT INFORMATION, UNFOLD PAGE TO LEFT.

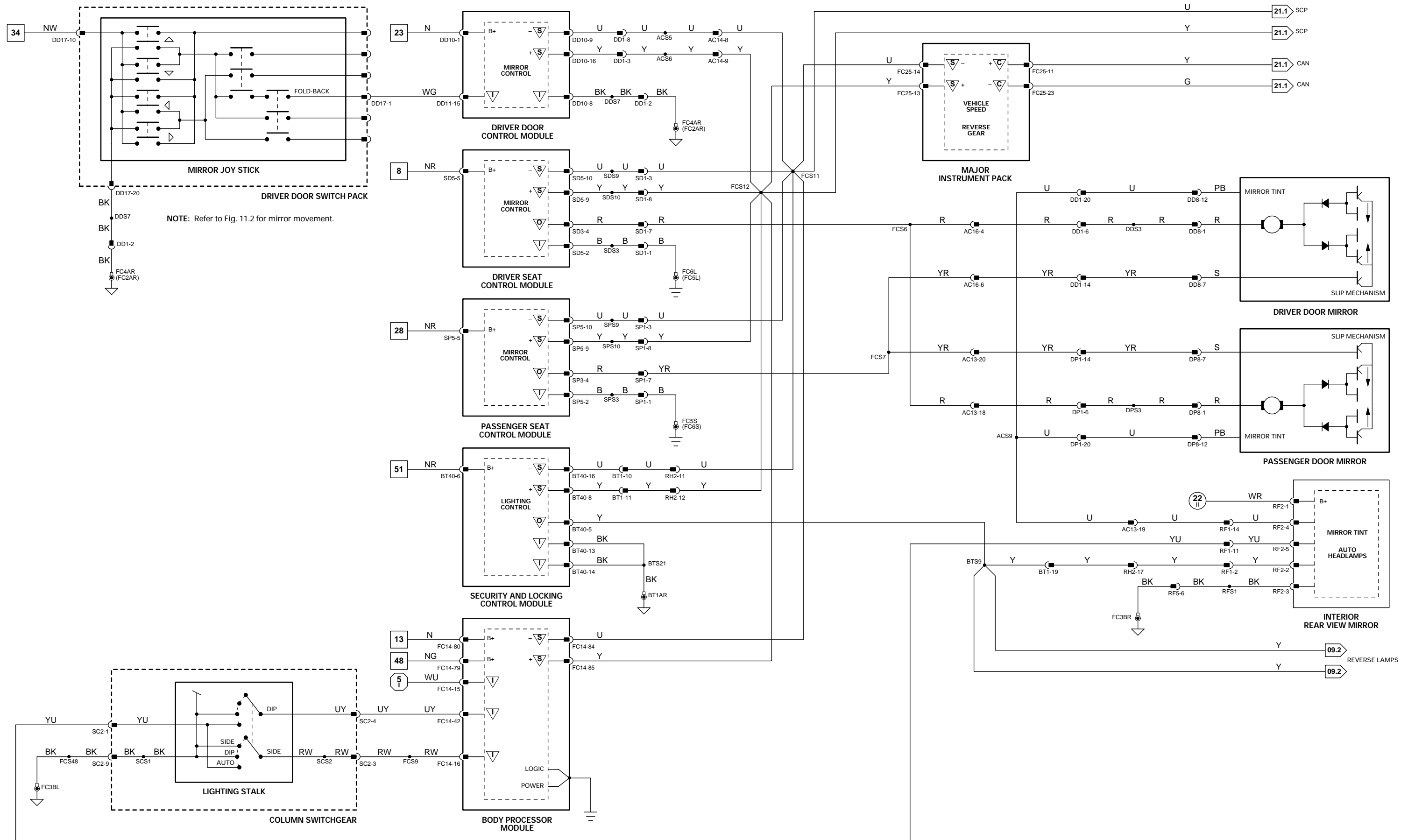

## CONTROL MODULE PIN OUT INFORMATION

### BODY PROCESSOR MODULE

Pin	Description	Active	Inactive
O	FC14-17	LHD RH (RHD LH) SEAT HEATER STATE LED	GROUND (LED ON)
I	FC14-35	LHD RH (RHD LH) SEAT HEATER REQUEST	GROUND
O	FC14-69	LHD LH SEAT HEATER STATUS LED (RHD = RH)	GROUND
I	FC14-80	BATTERY POWER SUPPLY (LOGIC)	B+
S	FC14-84	SCP NETWORK	2 – 1600 Hz
S	FC14-85	SCP NETWORK	2 – 1600 Hz
I	FC14-86	LHD LH (RHD RH) SEAT HEATER REQUEST	GROUND (MOMENTARY)

### DRIVER DOOR CONTROL MODULE

Pin	Description	Active	Inactive
I	DD10-1	BATTERY POWER SUPPLY	B+
I	DD10-8	LOGIC GROUND	GROUND
S	DD10-9	SCP NETWORK	2 – 1600 Hz
S	DD10-16	SCP NETWORK	2 – 1600 Hz
I	DD10-17	POWER GROUND	GROUND
O	DD11-2	SEAT MEMORY STATUS LED	GROUND (LED ON)
I	DD11-6	MEMORY SET REQUEST	B+
I	DD11-21	MEMORY 1 RECALL REQUEST	B+ (MOMENTARY)
I	DD11-22	MEMORY 2 RECALL REQUEST	B+ (MOMENTARY)

### DRIVER HEAD RESTRAINT CONTROL MODULE

Pin	Description	Active	Inactive
I	SD22-1	BATTERY POWER SUPPLY	B+
I	SD22-3	HEAD RESTRAINT UP REQUEST	B+ (MOMENTARY)
O	SD22-4	HEAD RESTRAINT MOTOR	B+
O	SD22-5	HEAD RESTRAINT MOTOR	B+
I	SD22-6	LOGIC GROUND	GROUND
I	SD22-7	POWER GROUND	GROUND
I	SD22-8	DRIVER OR PASSENGER SEAT IDENTIFICATION	GROUND (DRIVER)
I	SD22-9	HEAD RESTRAINT DOWN REQUEST	B+ (MOMENTARY)
SG	SD22-10	HEAD RESTRAINT POTENTIOMETER GROUND	GROUND
I	SD22-11	HEAD RESTRAINT POTENTIOMETER SIGNAL	10 V = UP; 2 V = DOWN
SS	SD22-12	HEAD RESTRAINT POTENTIOMETER SUPPLY	B+
S	SD22-13	SCP NETWORK	2 – 1600 Hz
S	SD22-14	SCP NETWORK	2 – 1600 Hz
I	SD22-15	SEAT BACK LATCHED	GROUND
I	SD22-16	SEAT BACK TILT	GROUND

### DRIVER SEAT CONTROL MODULE

Pin	Description	Active	Inactive
O	SD3-1	DRIVER SEAT SQUAB MOTOR SUPPLY – FORWARD	B+
O	SD3-2	DRIVER SEAT SQUAB MOTOR SUPPLY – REAR	B+
O	SD3-3	DRIVER SEAT HEATER ELEMENTS SUPPLY	B+
O	SD3-5	DRIVER SEAT REAR SEAT HEIGHT MOTOR SUPPLY	B+
O	SD3-6	DRIVER SEAT REAR SEAT HEIGHT MOTOR SUPPLY	B+
O	SD3-7	DRIVER SEAT FORE / AFT MOTOR SUPPLY	B+
O	SD3-8	DRIVER SEAT FORE / AFT MOTOR SUPPLY	B+
I	SD3-9	DRIVER SEAT FORE MOVEMENT REQUEST	B+ (MOMENTARY)
I	SD3-10	DRIVER SEAT AFT MOVEMENT REQUEST	B+ (MOMENTARY)
I	SD3-11	DRIVER SEAT LOWER REQUEST	B+ (MOMENTARY)
I	SD3-12	DRIVER SEAT RAISE REQUEST	B+ (MOMENTARY)
I	SD3-13	DRIVER SEAT REAR HEIGHT LOWER REQUEST	B+ (MOMENTARY)
I	SD3-14	DRIVER SEAT REAR HEIGHT RAISE REQUEST	B+ (MOMENTARY)
I	SD3-15	DRIVER SEAT SQUAB AFT RECLINE REQUEST	B+ (MOMENTARY)
I	SD3-16	DRIVER SEAT SQUAB FORE RECLINE REQUEST	B+ (MOMENTARY)
SG	SD4-1	DRIVER SEAT SQUAB POTENTIOMETER REFERENCE GROUND	GROUND
SS	SD4-2	DRIVER SEAT FORE / AFT MOVEMENT POTENTIOMETER REFERENCE VOLTAGE	B+
SS	SD4-5	DRIVER SEAT SQUAB POTENTIOMETER REFERENCE VOLTAGE	B+
SG	SD4-6	DRIVER SEAT FORE / AFT MOVEMENT POTENTIOMETER REFERENCE GROUND	GROUND
I	SD4-8	DRIVER SEAT REAR SEAT HEIGHT POTENTIOMETER SIGNAL	10 V = UP; 2 V = DOWN
I	SD4-10	DRIVER SEAT RAISE / LOWER POTENTIOMETER SIGNAL	10 V = UP; 2 V = DOWN
I	SD4-11	DRIVER SEAT SQUAB POTENTIOMETER SIGNAL	9 V = UP; 4 V = DOWN
I	SD4-12	DRIVER SEAT FORE / AFT POTENTIOMETER SIGNAL	10 V = FORWARD; 2 V = REAR
SS	SD4-14	DRIVER SEAT RAISE / LOWER POTENTIOMETER REFERENCE VOLTAGE	B+
SS	SD4-15	DRIVER SEAT REAR SEAT HEIGHT POTENTIOMETER REFERENCE VOLTAGE	B+
SG	SD4-18	DRIVER SEAT RAISE / LOWER POTENTIOMETER REFERENCE GROUND	GROUND
SG	SD4-19	DRIVER SEAT REAR SEAT HEIGHT POTENTIOMETER REFERENCE GROUND	GROUND
I	SD5-1	DRIVER OR PASSENGER SEAT IDENTIFICATION	GROUND (DRIVER)
I	SD5-2	POWER GROUND	GROUND
O	SD5-3	DRIVER SEAT RAISE / LOWER MOTOR SUPPLY	B+
O	SD5-4	DRIVER SEAT RAISE / LOWER MOTOR SUPPLY	B+
I	SD5-5	BATTERY POWER SUPPLY	B+
I	SD5-8	DRIVER SEAT BELT FASTENED	B+ (FASTENED)
S	SD5-9	SCP NETWORK	2 – 1600 Hz
S	SD5-10	SCP NETWORK	2 – 1600 Hz

NOTE: Refer to the Appendix at the rear of this book for CAN and SCP Network Messages.

The following abbreviations are used to represent values for Control Module Pin-Out data

I	Input	SG	Sensor Ground	S	SCP Network	V	Voltage (DC)
O	Output	A	ACP Network	D	Serial and Encoded Data	Hz	Frequency
SS	Sensor Supply V	C	CAN (Network)	B+	Battery Voltage	kHz	Frequency x 1000

CAUTION: The information on this data page is furnished to aid the user in understanding circuit operation. THIS INFORMATION SHOULD BE USED FOR REFERENCE ONLY.

NOTE: The values listed are approximately those that can be expected at the control module connector pins with all circuit connections made and all components connected and fitted. “Active” means a load is applied or a switch is ON; “Inactive” means a load is not applied or a switch is OFF.

Fig. 12.1

### COMPONENTS

Component	Connector / Type / Color	Location / Access
BODY PROCESSOR MODULE	FC14 / 104-WAY AMP EEEC / GREY	PASSENGER SIDE FASCIA / AIRBAG BRACKET
DOOR CONTROL MODULE – DRIVER	DD10 / 22-WAY FORD 2.8 TIMER / BLUE DD11 / 22-WAY FORD 2.8 TIMER / BLACK SD22 / 16-WAY FORD IDC / BLACK	DRIVER DOOR / DOOR CASING
HEAD RESTRAINT CONTROL MODULE – DRIVER	SD23 / 6-WAY MULTILOCK 070 / YELLOW	BEHIND SEAT BACK FINISHER
HEAD RESTRAINT MOTOR – DRIVER	SD25 / 2-WAY CONNECTOR / BLACK	BEHIND SEAT BACK FINISHER
SEAT BACK LATCH SWITCH	SD24 / 2-WAY CONNECTOR / BLACK	BEHIND SEAT BACK FINISHER
SEAT BACK TILT SWITCH	LHD: RH35 / 3-WAY CONNECTOR / BLACK RHD: RH36 / 3-WAY CONNECTOR / BLACK	BEHIND REAR QUARTER TRIM PANEL
SEAT BELT COMFORT SOLENOID – DRIVER	SD20 / 2-WAY MULTILOCK 040 / BLACK	BEHIND REAR QUARTER TRIM PANEL
SEAT BELT SWITCH – DRIVER	SD3 / 16-WAY FORD 2.8 TIMER / BLACK	BELOW SEAT CUSHION
SEAT CONTROL MODULE – DRIVER	SD4 / 26-WAY FORD IDC / BLACK SD5 / 10-WAY FORD 2.8 TIMER / BLACK	BELOW SEAT CUSHION
SEAT CUSHION (HEATER) – DRIVER	SD19 / 3-WAY MULTILOCK 070 / YELLOW	SEAT CUSHION
SEAT HEATER SWITCH (CENTER CONSOLE SWITCH PACK)	FC55 / 20-WAY FORD IDC / BLACK	CENTER CONSOLE SWITCH PACK
SEAT LUMBAR PUMP – DRIVER	SD14 / 3-WAY MULTILOCK 070 / YELLOW	SEAT BACK
SEAT MOTORS – DRIVER	SD7 / 6-WAY MULTILOCK 070 / WHITE SD8 / 6-WAY MULTILOCK 070 / WHITE SD9 / 6-WAY MULTILOCK 070 / GREY SD10 / 6-WAY MULTILOCK 070 / YELLOW	BELOW SEAT CUSHION
SQUAB (HEATER) – DRIVER	SD17 / 3-WAY MULTILOCK 070 / GREY	SEAT SQUAB
SWITCH PACK – DRIVER DOOR MEMORY	DD5 / 10-WAY AMP MQL / BLACK	DRIVER DOOR
SWITCH PACK – DRIVER SEAT	SD11 / 16-WAY MULTILOCK 040 / BLACK	DRIVER SEAT

### HARNESSTO-HARNESSTO CONNECTORS

Connector	Type / Color	Location / Access
AC14	14-WAY MULTILOCK 070 / GREY	FASCIA BOTTOM CONNECTOR MOUNTING BRACKET / RIGHT HAND SIDE
DD1	23-WAY AMP – FORD / BLACK	DRIVER SIDE ‘A’ POST MOUNTING BRACKET/ ‘A’ POST TRIM
RH9	20-WAY MULTILOCK 070 / YELLOW	BELOW CENTER CONSOLE
SD1	14-WAY MULTILOCK 070 / YELLOW	BELOW DRIVER SEAT

### GROUNDS

Ground	Location / Type
FC1S	EYELET (SINGLE) / TRANSMISSION TUNNEL, RIGHT HAND SIDE
FC2AR	EYELET (PAIR) – RIGHT HAND LEG / RIGHT HAND ‘A’ POST
FC2BR	EYELET (PAIR) – RIGHT HAND LEG / RIGHT HAND ‘A’ POST
FC4AR	EYELET (PAIR) – RIGHT HAND LEG / LEFT HAND ‘A’ POST
FC4BR	EYELET (PAIR) – RIGHT HAND LEG / LEFT HAND ‘A’ POST
FC5L	EYELET (PAIR) – LEFT HAND LEG / RIGHT HAND SEAT
FC5R	EYELET (PAIR) – RIGHT HAND LEG / RIGHT HAND SEAT
FC6L	EYELET (PAIR) – LEFT HAND LEG / LEFT HAND SEAT
FC6R	EYELET (PAIR) – RIGHT HAND LEG / LEFT HAND SEAT

FOR CONTROL MODULE PIN OUT INFORMATION, UNFOLD PAGE TO LEFT.

Refer to the front of this book for detailed information and illustrations regarding the location and identification of harnesses, relays, grounds, control modules and control module pins.



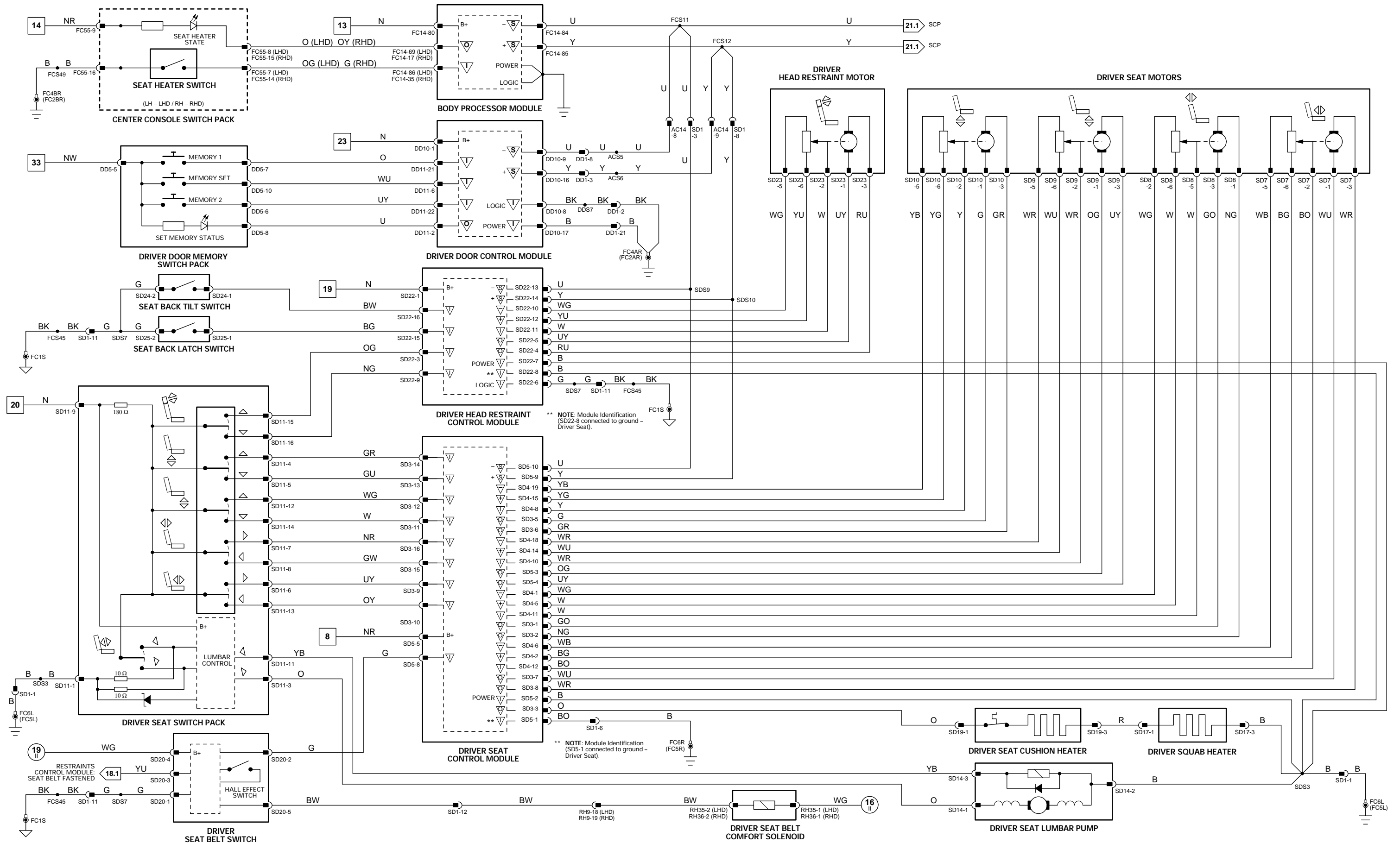

## CONTROL MODULE PIN OUT INFORMATION

### BODY PROCESSOR MODULE

Pin	Description	Active	Inactive
O	FC14-17	LHD RH (RHD LH) SEAT HEATER STATUS LED	GROUND (LED ON)
I	FC14-35	LHD RH (RHD LH) SEAT HEATER REQUEST	GROUND
O	FC14-69	LHD LH (RHD RH) SEAT HEATER STATUS LED	GROUND
I	FC14-80	BATTERY POWER SUPPLY (LOGIC)	B+
S	FC14-84	SCP NETWORK	2 – 1600 Hz
S	FC14-85	SCP NETWORK	2 – 1600 Hz
I	FC14-86	LHD LH (RHD RH) SEAT HEATER REQUEST	GROUND (MOMENTARY)

### DRIVER HEAD RESTRAINT CONTROL MODULE

Pin	Description	Active	Inactive
I	SD22-1	BATTERY POWER SUPPLY	B+
I	SD22-3	HEAD RESTRAINT UP REQUEST	B+ (MOMENTARY)
O	SD22-4	HEAD RESTRAINT MOTOR	B+
O	SD22-5	HEAD RESTRAINT MOTOR	B+
I	SD22-6	LOGIC GROUND	GROUND
I	SD22-7	POWER GROUND	GROUND
I	SD22-8	DRIVER OR PASSENGER SEAT IDENTIFICATION	GROUND (DRIVER)
I	SD22-9	HEAD RESTRAINT DOWN REQUEST	B+ (MOMENTARY)
SG	SD22-10	HEAD RESTRAINT POTENTIOMETER GROUND	GROUND
I	SD22-11	HEAD RESTRAINT POTENTIOMETER SIGNAL	10 V = UP; 2 V = DOWN
SS	SD22-12	HEAD RESTRAINT POTENTIOMETER SUPPLY	B+
S	SD22-13	SCP NETWORK	2 – 1600 Hz
S	SD22-14	SCP NETWORK	2 – 1600 Hz
I	SD22-15	SEAT BACK LATCHED	GROUND
I	SD22-16	SEAT BACK TILT	GROUND

### DRIVER SEAT CONTROL MODULE

Pin	Description	Active	Inactive
O	SD3-1	DRIVER SEAT SQUAB MOTOR SUPPLY – FORWARD	B+
O	SD3-2	DRIVER SEAT SQUAB MOTOR SUPPLY – REAR	B+
O	SD3-3	DRIVER SEAT HEATER ELEMENTS SUPPLY	B+
O	SD3-5	DRIVER SEAT REAR SEAT HEIGHT MOTOR SUPPLY	B+
O	SD3-6	DRIVER SEAT REAR SEAT HEIGHT MOTOR SUPPLY	B+
O	SD3-7	DRIVER SEAT FORE / AFT MOTOR SUPPLY	B+
O	SD3-8	DRIVER SEAT FORE / AFT MOTOR SUPPLY	B+
I	SD3-9	DRIVER SEAT FORE MOVEMENT REQUEST	B+ (MOMENTARY)
I	SD3-10	DRIVER SEAT AFT MOVEMENT REQUEST	B+ (MOMENTARY)
I	SD3-11	DRIVER SEAT LOWER REQUEST	B+ (MOMENTARY)
I	SD3-12	DRIVER SEAT RAISE REQUEST	B+ (MOMENTARY)
I	SD3-13	DRIVER SEAT REAR HEIGHT LOWER REQUEST	B+ (MOMENTARY)
I	SD3-14	DRIVER SEAT REAR HEIGHT RAISE REQUEST	B+ (MOMENTARY)
I	SD3-15	DRIVER SEAT SQUAB AFT RECLINE REQUEST	B+ (MOMENTARY)
I	SD3-16	DRIVER SEAT SQUAB FORE RECLINE REQUEST	B+ (MOMENTARY)
I	SD5-1	DRIVER OR PASSENGER SEAT IDENTIFICATION	GROUND (DRIVER)
I	SD5-2	POWER GROUND	GROUND
O	SD5-3	DRIVER SEAT RAISE / LOWER MOTOR SUPPLY	B+
O	SD5-4	DRIVER SEAT RAISE / LOWER MOTOR SUPPLY	B+
I	SD5-5	BATTERY POWER SUPPLY	B+
I	SD5-8	DRIVER SEAT BELT FASTENED	B+ (FASTENED)
S	SD5-9	SCP NETWORK	2 – 1600 Hz
S	SD5-10	SCP NETWORK	2 – 1600 Hz

NOTE: Refer to the Appendix at the rear of this book for CAN and SCP Network Messages.

Fig. 12.2

### COMPONENTS

Component	Connector / Type / Color	Location / Access
BODY PROCESSOR MODULE	FC14 / 104-WAY AMP EEEC / GREY	PASSENGER SIDE FASCIA / AIRBAG BRACKET
HEAD RESTRAINT CONTROL MODULE – DRIVER	SD22 / 16-WAY FORD IDC / BLACK	BEHIND SEAT BACK FINISHER
HEAD RESTRAINT MOTOR – DRIVER	SD23 / 6-WAY MULTILOCK 070 / YELLOW	BEHIND SEAT BACK FINISHER
SEAT BACK LATCH SWITCH	SD25 / 2-WAY CONNECTOR / BLACK	BEHIND SEAT BACK FINISHER
SEAT BACK TILT SWITCH	SD24 / 2-WAY CONNECTOR / BLACK	BEHIND SEAT BACK FINISHER
SEAT BELT COMFORT SOLENOID – DRIVER	LHD: RH35 / 3-WAY CONNECTOR / BLACK RHD: RH36 / 3-WAY CONNECTOR / BLACK	BEHIND REAR QUARTER TRIM PANEL
SEAT BELT SWITCH – DRIVER	SD20 / 2-WAY MULTILOCK 040 / BLACK	BELOW SEAT CUSHION
SEAT CONTROL MODULE – DRIVER	SD3 / 16-WAY FORD 2.8 TIMER / BLACK SD4 / 26-WAY FORD IDC / BLACK SD5 / 10-WAY FORD 2.8 TIMER / BLACK	BELOW SEAT CUSHION
SEAT CUSHION (HEATER) – DRIVER	SD19 / 3-WAY MULTILOCK 070 / YELLOW	SEAT CUSHION
SEAT HEATER SWITCH (CENTER CONSOLE SWITCH PACK)	FC55 / 20-WAY FORD IDC / BLACK	CENTER CONSOLE SWITCH PACK
SEAT LUMBAR PUMP – DRIVER	SD14 / 3-WAY MULTILOCK 070 / YELLOW	SEAT BACK
SEAT MOTORS – DRIVER	SD7 / 6-WAY MULTILOCK 070 / WHITE SD8 / 6-WAY MULTILOCK 070 / WHITE SD9 / 6-WAY MULTILOCK 070 / GREY SD10 / 6-WAY MULTILOCK 070 / YELLOW	BELOW SEAT CUSHION
SQUAB (HEATER) – DRIVER	SD17 / 3-WAY MULTILOCK 070 / GREY	SEAT SQUAB
SWITCH PACK – DRIVER SEAT	SD11 / 16-WAY MULTILOCK 040 / BLACK	DRIVER SEAT

### HARNESSTO-HARNESSTO CONNECTORS

Connector	Type / Color	Location / Access
RH9	20-WAY MULTILOCK 070 / YELLOW	BELOW CENTER CONSOLE
SD1	14-WAY MULTILOCK 070 / YELLOW	BELOW DRIVER SEAT

### GROUNDST

Ground	Location / Type
FC1S	EYELET (SINGLE) / TRANSMISSION TUNNEL, RIGHT HAND SIDE
FC2BR	EYELET (PAIR) – RIGHT HAND LEG / RIGHT HAND 'A' POST
FC4BR	EYELET (PAIR) – RIGHT HAND LEG / LEFT HAND 'A' POST
FC5L	EYELET (PAIR) – LEFT HAND LEG / RIGHT HAND SEAT
FC5R	EYELET (PAIR) – RIGHT HAND LEG / RIGHT HAND SEAT
FC6L	EYELET (PAIR) – LEFT HAND LEG / LEFT HAND SEAT
FC6R	EYELET (PAIR) – RIGHT HAND LEG / LEFT HAND SEAT

FOR CONTROL MODULE PIN OUT INFORMATION, UNFOLD PAGE TO LEFT.

The following abbreviations are used to represent values for Control Module Pin-Out data

I	Input	SG	Sensor Ground	S	SCP Network	V	Voltage (DC)
O	Output	A	ACP Network	D	Serial and Encoded Data	Hz	Frequency
SS	Sensor Supply V	C	CAN (Network)	B+	Battery Voltage	kHz	Frequency x 1000

CAUTION: The information on this data page is furnished to aid the user in understanding circuit operation. THIS INFORMATION SHOULD BE USED FOR REFERENCE ONLY.

NOTE: The values listed are approximately those that can be expected at the control module connector pins with all circuit connections made and all components connected and fitted. "Active" means a load is applied or a switch is ON; "Inactive" means a load is not applied or a switch is OFF.

Refer to the front of this book for detailed information and illustrations regarding the location and identification of harnesses, relays, grounds, control modules and control module pins.

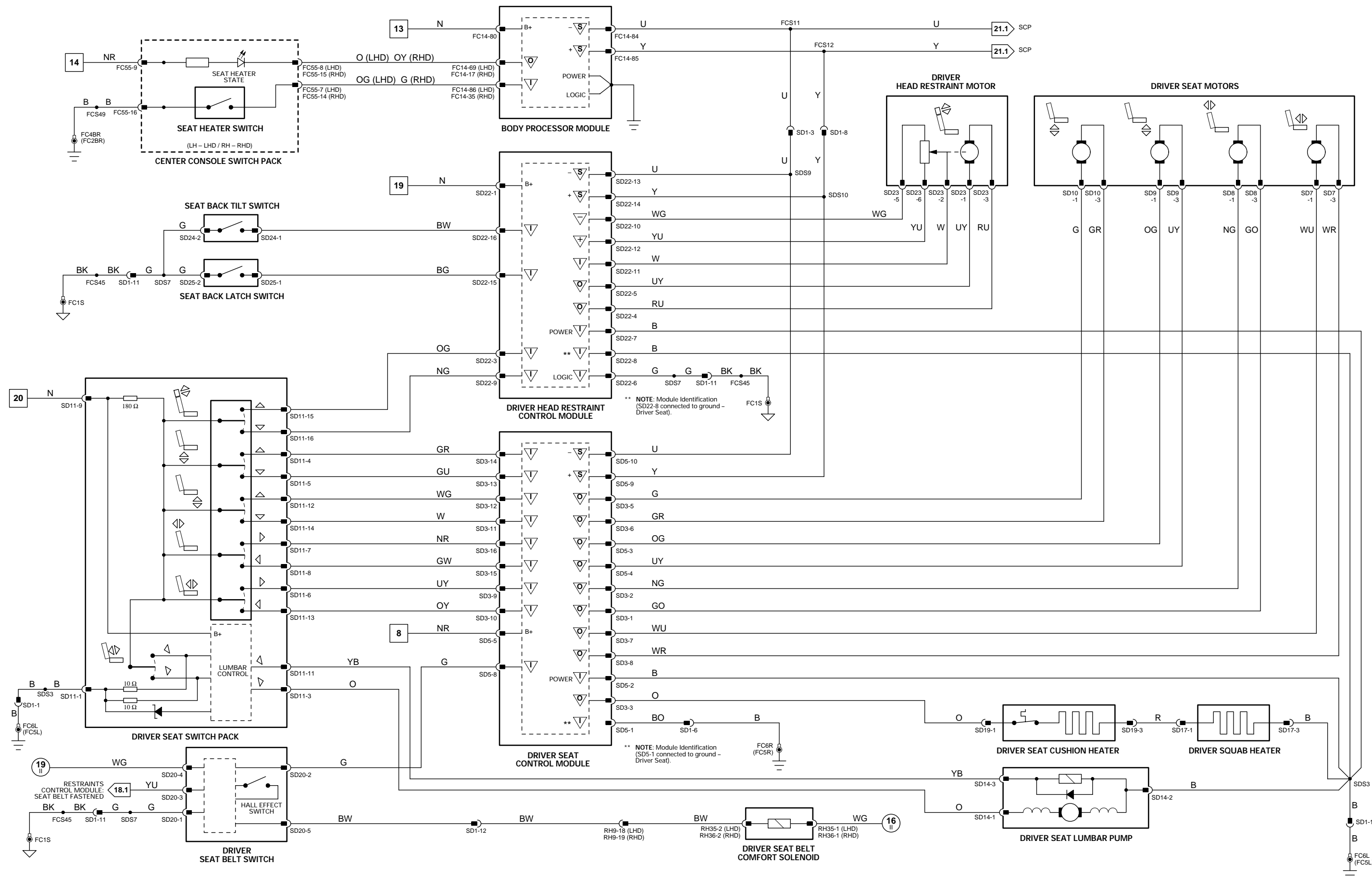

## CONTROL MODULE PIN OUT INFORMATION

### BODY PROCESSOR MODULE

Pin	Description	Active	Inactive
O	FC14-17	LHD RH (RHD LH) SEAT HEATER STATUS LED	GROUND (LED ON)
I	FC14-35	LHD RH (RHD LH) SEAT HEATER REQUEST	GROUND
O	FC14-69	LHD LH (RHD RH) SEAT HEATER STATUS LED	GROUND
I	FC14-80	BATTERY POWER SUPPLY (LOGIC)	B+
S	FC14-84	SCP NETWORK	2 – 1600 Hz
S	FC14-85	SCP NETWORK	2 – 1600 Hz
I	FC14-86	LHD LH (RHD RH) SEAT HEATER REQUEST	GROUND (MOMENTARY)

### PASSENGER HEAD RESTRAINT CONTROL MODULE

Pin	Description	Active	Inactive
I	SP22-1	BATTERY POWER SUPPLY	B+
I	SP22-3	HEAD RESTRAINT UP REQUEST	B+ (MOMENTARY)
O	SP22-4	HEAD RESTRAINT MOTOR	B+
O	SP22-5	HEAD RESTRAINT MOTOR	B+
I	SP22-6	LOGIC GROUND	GROUND
I	SP22-7	POWER GROUND	GROUND
I	SP22-8	DRIVER OR PASSENGER SEAT IDENTIFICATION	GROUND (DRIVER)
I	SP22-9	HEAD RESTRAINT DOWN REQUEST	B+ (MOMENTARY)
SG	SP22-10	HEAD RESTRAINT POTENTIOMETER GROUND	GROUND
I	SP22-11	HEAD RESTRAINT POTENTIOMETER SIGNAL	10 V = UP; 2 V = DOWN
SS	SP22-12	HEAD RESTRAINT POTENTIOMETER SUPPLY	B+
S	SP22-13	SCP NETWORK	2 – 1600 Hz
S	SP22-14	SCP NETWORK	2 – 1600 Hz
I	SP22-15	SEAT BACK LATCHED	GROUND
I	SP22-16	SEAT BACK TILT	GROUND

### PASSENGER SEAT CONTROL MODULE

Pin	Description	Active	Inactive
O	SP3-1	PASSENGER SEAT SQUAB MOTOR SUPPLY – FORWARD	B+
O	SP3-2	PASSENGER SEAT SQUAB MOTOR SUPPLY – REAR	B+
O	SP3-3	PASSENGER SEAT HEATER ELEMENTS SUPPLY	B+
O	SP3-5	PASSENGER SEAT REAR SEAT HEIGHT MOTOR SUPPLY	B+
O	SP3-6	PASSENGER SEAT REAR SEAT HEIGHT MOTOR SUPPLY	B+
O	SP3-7	PASSENGER SEAT FORE / AFT MOTOR SUPPLY	B+
O	SP3-8	PASSENGER SEAT FORE / AFT MOTOR SUPPLY	B+
I	SP3-9	PASSENGER SEAT FORE MOVEMENT REQUEST	B+ (MOMENTARY)
I	SP3-10	PASSENGER SEAT AFT MOVEMENT REQUEST	B+ (MOMENTARY)
I	SP3-11	PASSENGER SEAT LOWER REQUEST	B+ (MOMENTARY)
I	SP3-12	PASSENGER SEAT RAISE REQUEST	B+ (MOMENTARY)
I	SP3-13	PASSENGER SEAT REAR HEIGHT LOWER REQUEST	B+ (MOMENTARY)
I	SP3-14	PASSENGER SEAT REAR HEIGHT RAISE REQUEST	B+ (MOMENTARY)
I	SP3-15	PASSENGER SEAT SQUAB AFT RECLINE REQUEST	B+ (MOMENTARY)
I	SP3-16	PASSENGER SEAT SQUAB FORE RECLINE REQUEST	B+ (MOMENTARY)
I	SP5-1	PASSENGER OR PASSENGER SEAT IDENTIFICATION	GROUND (DRIVER)
I	SP5-2	POWER GROUND	GROUND
O	SP5-3	PASSENGER SEAT RAISE / LOWER MOTOR SUPPLY	B+
O	SP5-4	PASSENGER SEAT RAISE / LOWER MOTOR SUPPLY	B+
I	SP5-5	BATTERY POWER SUPPLY	B+
S	SP5-9	SCP NETWORK	2 – 1600 Hz
S	SP5-10	SCP NETWORK	2 – 1600 Hz

NOTE: Refer to the Appendix at the rear of this book for CAN and SCP Network Messages.

## Fig. 12.3

### COMPONENTS

Component	Connector / Type / Color	Location / Access
BODY PROCESSOR MODULE	FC14 / 104-WAY AMP EEEC / GREY	PASSENGER SIDE FASCIA / AIRBAG BRACKET
HEAD RESTRAINT CONTROL MODULE – PASSENGER	SP22 / 16-WAY FORD IDC / BLACK	BEHIND SEAT BACK FINISHER
HEAD RESTRAINT MOTOR – PASSENGER	SP23 / 6-WAY MULTILOCK 070 / YELLOW	BEHIND SEAT BACK FINISHER
SEAT BACK LATCH SWITCH	SP25 / 2-WAY CONNECTOR / BLACK	BEHIND SEAT BACK FINISHER
SEAT BACK TILT SWITCH	SP24 / 2-WAY CONNECTOR / BLACK	BEHIND SEAT BACK FINISHER
SEAT BELT COMFORT SOLENOID – PASSENGER	RHD: RH35 / 3-WAY CONNECTOR / BLACK LHD: RH36 / 3-WAY CONNECTOR / BLACK	BEHIND REAR QUARTER TRIM PANEL
SEAT BELT SWITCH – PASSENGER	SP20 / 2-WAY MULTILOCK 040 / BLACK	BELOW SEAT CUSHION
SEAT CONTROL MODULE – PASSENGER	SP3 / 16-WAY FORD 2.8 TIMER / BLACK SP4 / 26-WAY FORD IDC / BLACK SP5 / 10-WAY FORD 2.8 TIMER / BLACK	BELOW SEAT CUSHION
SEAT CUSHION (HEATER) – PASSENGER	SP19 / 3-WAY MULTILOCK 070 / YELLOW	SEAT CUSHION
SEAT HEATER SWITCH (CENTER CONSOLE SWITCH PACK)	FC55 / 20-WAY FORD IDC / BLACK	CENTER CONSOLE SWITCH PACK
SEAT LUMBAR PUMP – PASSENGER	SP14 / 3-WAY MULTILOCK 070 / YELLOW	SEAT BACK
SEAT MOTORS – PASSENGER	SP7 / 6-WAY MULTILOCK 070 / WHITE SP8 / 6-WAY MULTILOCK 070 / WHITE SP9 / 6-WAY MULTILOCK 070 / YELLOW SP10 / 6-WAY MULTILOCK 070 / YELLOW	BELOW SEAT CUSHION
SQUAB (HEATER) – PASSENGER	SP17 / 3-WAY MULTILOCK 070 / GREY	SEAT SQUAB
SWITCH PACK – PASSENGER SEAT	SP11 / 16-WAY MULTILOCK 040 / BLACK	PASSENGER SEAT

### HARNESS-TO-HARNESS CONNECTORS

Connector	Type / Color	Location / Access
RH9	20-WAY MULTILOCK 070 / YELLOW	BELOW CENTER CONSOLE
SP1	14-WAY MULTILOCK 070 / YELLOW	BELOW PASSENGER SEAT

### GROUND

Ground	Location / Type
FC1S	EYELET (SINGLE) / TRANSMISSION TUNNEL, RIGHT HAND SIDE
FC2BR	EYELET (PAIR) – RIGHT HAND LEG / RIGHT HAND 'A' POST
FC4BR	EYELET (PAIR) – RIGHT HAND LEG / LEFT HAND 'A' POST
FC5S	EYELET (SINGLE) / RIGHT HAND SEAT
FC6S	EYELET (SINGLE) / LEFT HAND SEAT

FOR CONTROL MODULE PIN OUT INFORMATION, UNFOLD PAGE TO LEFT.

The following abbreviations are used to represent values for Control Module Pin-Out data

I	Input	SG	Sensor Ground	S	SCP Network	V	Voltage (DC)
O	Output	A	ACP Network	D	Serial and Encoded Data	Hz	Frequency
SS	Sensor Supply V	C	CAN (Network)	B+	Battery Voltage	kHz	Frequency x 1000

CAUTION: The information on this data page is furnished to aid the user in understanding circuit operation. THIS INFORMATION SHOULD BE USED FOR REFERENCE ONLY.

NOTE: The values listed are approximately those that can be expected at the control module connector pins with all circuit connections made and all components connected and fitted. "Active" means a load is applied or a switch is ON; "Inactive" means a load is not applied or a switch is OFF.

Refer to the front of this book for detailed information and illustrations regarding the location and identification of harnesses, relays, grounds, control modules and control module pins.

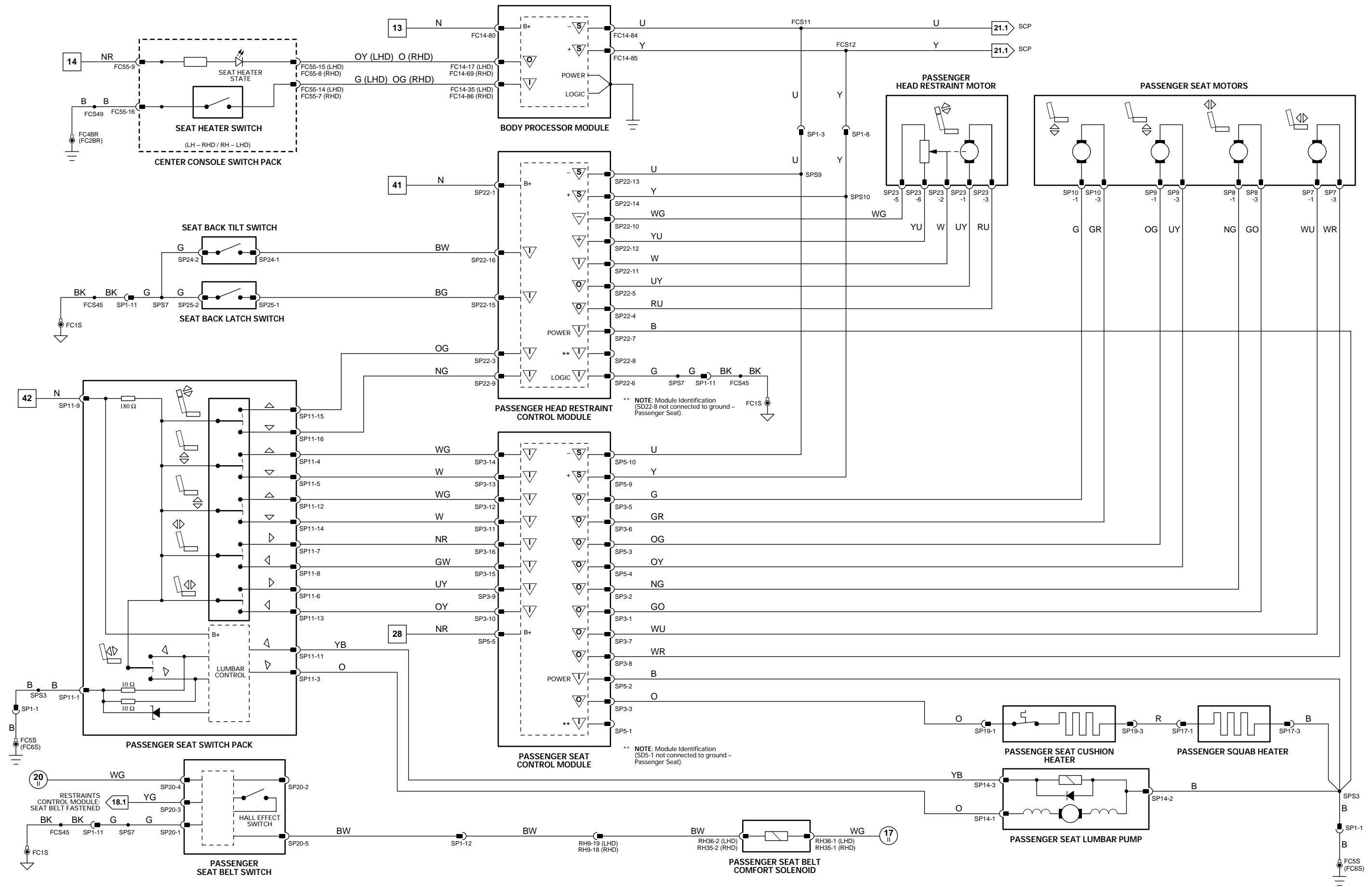

## CONTROL MODULE PIN OUT INFORMATION

### BODY PROCESSOR MODULE

Pin	Description	Active	Inactive
O	FC14-17	LHD RH (RHD LH) SEAT HEATER STATUS LED	GROUND (LED ON)
I	FC14-35	LHD RH (RHD LH) SEAT HEATER REQUEST	GROUND
O	FC14-69	LHD LH (RHD RH) SEAT HEATER STATUS LED	GROUND
I	FC14-80	BATTERY POWER SUPPLY (LOGIC)	B+
S	FC14-84	SCP NETWORK	2 – 1600 Hz
S	FC14-85	SCP NETWORK	2 – 1600 Hz
I	FC14-86	LHD LH (RHD RH) SEAT HEATER REQUEST	GROUND (MOMENTARY)

### PASSENGER HEAD RESTRAINT CONTROL MODULE

Pin	Description	Active	Inactive
I	SP22-1	BATTERY POWER SUPPLY	B+
O	SP22-3	HEAD RESTRAINT UP REQUEST	B+ (MOMENTARY)
I	SP22-4	HEAD RESTRAINT MOTOR	B+
O	SP22-5	HEAD RESTRAINT MOTOR	B+
I	SP22-6	LOGIC GROUND	GROUND
I	SP22-7	POWER GROUND	GROUND
I	SP22-8	DRIVER OR PASSENGER SEAT IDENTIFICATION	GROUND (DRIVER)
I	SP22-9	HEAD RESTRAINT DOWN REQUEST	B+ (MOMENTARY)
SG	SP22-10	HEAD RESTRAINT POTENTIOMETER GROUND	GROUND
I	SP22-11	HEAD RESTRAINT POTENTIOMETER SIGNAL	10 V = UP; 2 V = DOWN
SS	SP22-12	HEAD RESTRAINT POTENTIOMETER SUPPLY	B+
S	SP22-13	SCP NETWORK	2 – 1600 Hz
S	SP22-14	SCP NETWORK	2 – 1600 Hz
I	SP22-15	SEAT BACK LATCHED	GROUND
I	SP22-16	SEAT BACK TILT	GROUND

### PASSENGER SEAT CONTROL MODULE

Pin	Description	Active	Inactive
O	SP3-1	PASSENGER SEAT SQUAB MOTOR SUPPLY – FORWARD	B+
O	SP3-2	PASSENGER SEAT SQUAB MOTOR SUPPLY – REAR	B+
O	SP3-3	PASSENGER SEAT HEATER ELEMENTS SUPPLY	B+
O	SP3-7	PASSENGER SEAT FORE / AFT MOTOR SUPPLY	B+
O	SP3-8	PASSENGER SEAT FORE / AFT MOTOR SUPPLY	B+
I	SP3-9	PASSENGER SEAT FORE MOVEMENT REQUEST	B+ (MOMENTARY)
I	SP3-10	PASSENGER SEAT AFT MOVEMENT REQUEST	B+ (MOMENTARY)
I	SP3-11	PASSENGER SEAT LOWER REQUEST	B+ (MOMENTARY)
I	SP3-12	PASSENGER SEAT RAISE REQUEST	B+ (MOMENTARY)
I	SP3-13	PASSENGER SEAT REAR HEIGHT LOWER REQUEST	B+ (MOMENTARY)
I	SP3-14	PASSENGER SEAT REAR HEIGHT RAISE REQUEST	B+ (MOMENTARY)
I	SP3-15	PASSENGER SEAT SQUAB AFT RECLINE REQUEST	B+ (MOMENTARY)
I	SP3-16	PASSENGER SEAT SQUAB FORE RECLINE REQUEST	B+ (MOMENTARY)
I	SP5-1	PASSENGER OR PASSENGER SEAT IDENTIFICATION	GROUND (DRIVER)
I	SP5-2	POWER GROUND	GROUND
I	SP5-5	BATTERY POWER SUPPLY	B+
S	SP5-9	SCP NETWORK	2 – 1600 Hz
S	SP5-10	SCP NETWORK	2 – 1600 Hz

**NOTE:** Refer to the Appendix at the rear of this book for CAN and SCP Network Messages.

## Fig. 12.4

### COMPONENTS

Component	Connector / Type / Color	Location / Access
BODY PROCESSOR MODULE	FC14 / 104-WAY AMP EEEC / GREY	PASSENGER SIDE FASCIA / AIRBAG BRACKET
HEAD RESTRAINT CONTROL MODULE – PASSENGER	SP22 / 16-WAY FORD IDC / BLACK	BEHIND SEAT BACK FINISHER
HEAD RESTRAINT MOTOR – PASSENGER	SP23 / 6-WAY MULTILOCK 070 / YELLOW	BEHIND SEAT BACK FINISHER
SEAT BACK LATCH SWITCH	SP25 / 2-WAY CONNECTOR / BLACK	BEHIND SEAT BACK FINISHER
SEAT BACK TILT SWITCH	SP24 / 2-WAY CONNECTOR / BLACK	BEHIND SEAT BACK FINISHER
SEAT BELT COMFORT SOLENOID – PASSENGER	RHD: RH35 / 3-WAY CONNECTOR / BLACK LHD: RH36 / 3-WAY CONNECTOR / BLACK	BEHIND REAR QUARTER TRIM PANEL
SEAT BELT SWITCH – PASSENGER	SP20 / 2-WAY MULTILOCK 040 / BLACK	BELOW SEAT CUSHION
SEAT CONTROL MODULE – PASSENGER	SP3 / 16-WAY FORD 2.8 TIMER / BLACK SP4 / 26-WAY FORD IDC / BLACK SP5 / 10-WAY FORD 2.8 TIMER / BLACK	BELOW SEAT CUSHION
SEAT CUSHION (HEATER) – PASSENGER	SP19 / 3-WAY MULTILOCK 070 / YELLOW	SEAT CUSHION
SEAT HEATER SWITCH (CENTER CONSOLE SWITCH PACK)	FC55 / 20-WAY FORD IDC / BLACK	CENTER CONSOLE SWITCH PACK
SEAT LUMBAR PUMP – PASSENGER	SP14 / 3-WAY MULTILOCK 070 / YELLOW	SEAT BACK
SEAT MOTORS – PASSENGER	SP7 / 6-WAY MULTILOCK 070 / WHITE SP8 / 6-WAY MULTILOCK 070 / WHITE SP9 / 6-WAY MULTILOCK 070 / YELLOW SP10 / 6-WAY MULTILOCK 070 / YELLOW	BELOW SEAT CUSHION
SQUAB (HEATER) – PASSENGER	SP17 / 3-WAY MULTILOCK 070 / GREY	SEAT SQUAB
SWITCH PACK – PASSENGER SEAT	SP11 / 16-WAY MULTILOCK 040 / BLACK	PASSENGER SEAT

### HARNESS-TO-HARNESS CONNECTORS

Connector	Type / Color	Location / Access
RH9	20-WAY MULTILOCK 070 / YELLOW	BELOW CENTER CONSOLE
SP1	14-WAY MULTILOCK 070 / YELLOW	BELOW PASSENGER SEAT

### GROUND

Ground	Location / Type
FC1S	EYELET (SINGLE) / TRANSMISSION TUNNEL, RIGHT HAND SIDE
FC2BR	EYELET (PAIR) – RIGHT HAND LEG / RIGHT HAND 'A' POST
FC4BR	EYELET (PAIR) – RIGHT HAND LEG / LEFT HAND 'A' POST
FC5S	EYELET (SINGLE) / RIGHT HAND SEAT
FC6S	EYELET (SINGLE) / LEFT HAND SEAT

**FOR CONTROL MODULE PIN OUT INFORMATION, UNFOLD PAGE TO LEFT.**

The following abbreviations are used to represent values for Control Module Pin-Out data

I	Input	SG	Sensor Ground	S	SCP Network	V	Voltage (DC)
O	Output	A	ACP Network	D	Serial and Encoded Data	Hz	Frequency
SS	Sensor Supply V	C	CAN (Network)	B+	Battery Voltage	kHz	Frequency x 1000

**CAUTION:** The information on this data page is furnished to aid the user in understanding circuit operation. THIS INFORMATION SHOULD BE USED FOR REFERENCE ONLY.

**NOTE:** The values listed are approximately those that can be expected at the control module connector pins with all circuit connections made and all components connected and fitted. “Active” means a load is applied or a switch is ON; “Inactive” means a load is not applied or a switch is OFF.

Refer to the front of this book for detailed information and illustrations regarding the location and identification of harnesses, relays, grounds, control modules and control module pins.

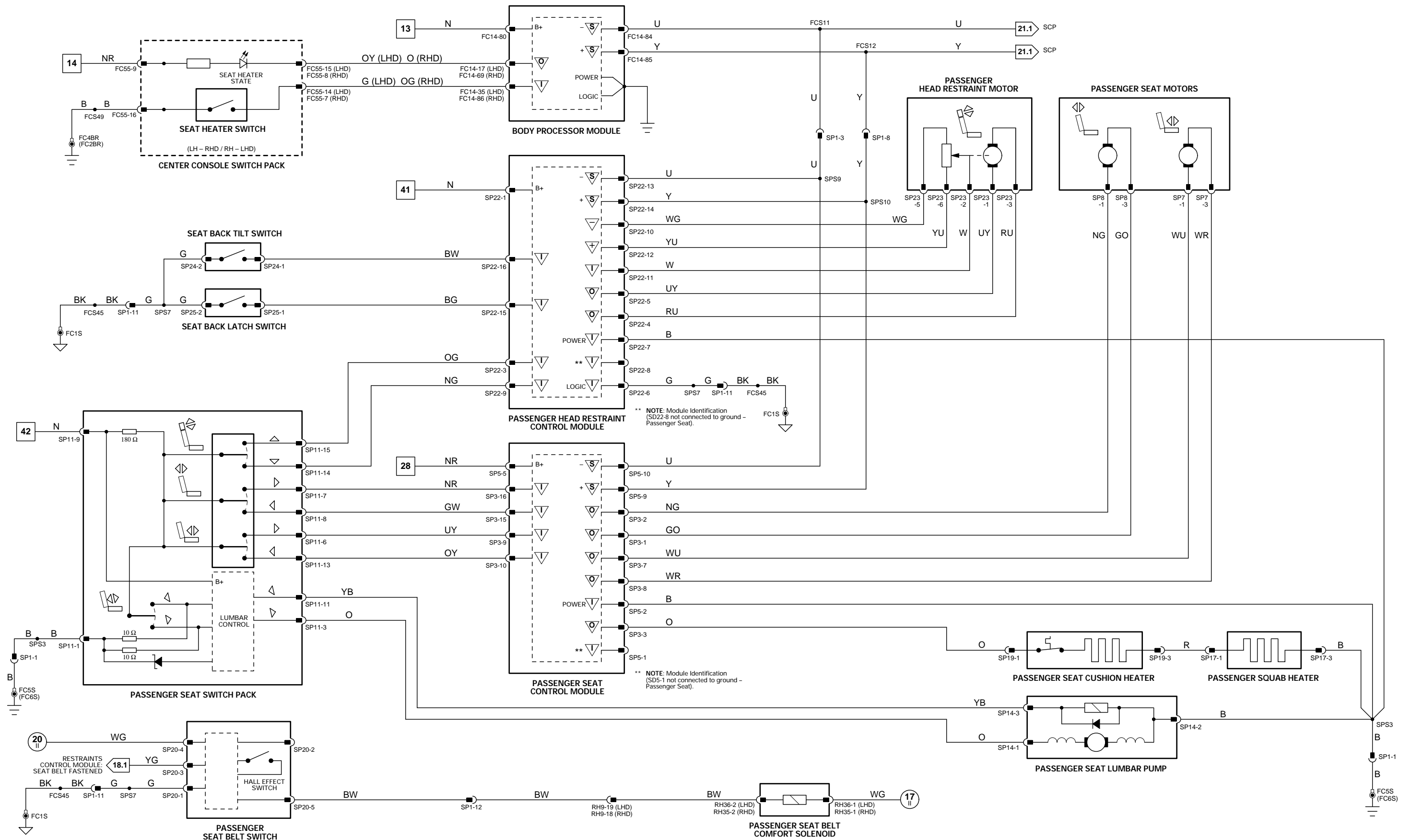

1 → 7 Fig. 01.1    1 → 5 Fig. 01.1    8 → 50 Fig. 01.2    51 → 90 Fig. 01.3    6 → 58 Fig. 01.4    59 → 73 Fig. 01.5    1 → 18 Fig. 02.1

Input  
 Sensor Supply V  
 Sensor Ground  
 ACP  
 SCP  
 CAN  
 Serial and Encoded Data

VARIANT: 3-Way Movement Vehicles  
 VIN RANGE: A11051 →  
 DATE OF ISSUE: September 2000

## CONTROL MODULE PIN OUT INFORMATION

### BODY PROCESSOR MODULE

Pin	Description	Active	Inactive
I FC14-5	TRUNK LATCH RELEASE REQUEST	GROUND (MOMENTARY)	B+
I FC14-15	IGNITION SWITCHED GROUND SUPPLY	GROUND	
I FC14-31	FUEL FLAP RELEASE REQUEST	GROUND (MOMENTARY)	B+
I FC14-33	IGNITION SWITCHED GROUND SUPPLY	GROUND	GROUND
I FC14-41	IGNITION GROUND SUPPLY	GROUND	
I FC14-55	VALET SWITCH	GROUND (MOMENTARY)	B+
I FC14-58	NOT-IN-PARK	GROUND (R,N,D,4,3,2)	B+ (PARK)
I FC14-67	KEY IN IGNITION	GROUND (KEY IN)	B+
O FC14-71	DOOR LOCK RELAY ACTIVATE	GROUND (PULSE)	B+
I FC14-80	BATTERY POWER SUPPLY (LOGIC)	B+	B+
S FC14-84	SCP NETWORK	2 – 1600 Hz	
S FC14-85	SCP NETWORK	2 – 1600 Hz	

### DRIVER DOOR CONTROL MODULE

Pin	Description	Active	Inactive
I DD10-1	BATTERY POWER SUPPLY	B+	B+
O DD10-5	DOOR LOCK ACTUATOR MOTOR UNLOCK	B+	GROUND
O DD10-6	DOOR LOCK ACTUATOR MOTOR LOCK	B+	GROUND
I DD10-8	LOGIC GROUND	GROUND	GROUND
S DD10-9	SCP NETWORK	2 – 1600 Hz	
S DD10-16	SCP NETWORK	2 – 1600 Hz	
I DD10-17	POWER GROUND	GROUND	GROUND
I DD11-4	DRIVER DOOR LOCK BARREL UNLOCK REQUEST	B+ (MOMENTARY)	GROUND
I DD11-5	EXTERIOR DOOR HANDLE WINDOW DROP REQUEST	B+	GROUND
I DD11-12	DRIVER DOOR LOCK BARREL LOCK REQUEST	B+ (MOMENTARY)	GROUND
I DD11-20	DRIVER DOOR SWITCH	GROUND (DOOR OPEN)	B+

### PASSENGER DOOR CONTROL MODULE

Pin	Description	Active	Inactive
I DP10-1	BATTERY POWER SUPPLY	B+	B+
O DP10-5	PASSENGER DOOR LOCK ACTUATOR MOTOR UNLOCK	B+	GROUND
O DP10-6	PASSENGER DOOR LOCK ACTUATOR MOTOR LOCK	B+	GROUND
I DP10-8	LOGIC GROUND	GROUND	GROUND
S DP10-9	SCP NETWORK	2 – 1600 Hz	
S DP10-16	SCP NETWORK	2 – 1600 Hz	
I DP10-17	POWER GROUND	GROUND	GROUND
I DP11-5	EXTERIOR DOOR HANDLE WINDOW DROP REQUEST	B+	GROUND
I DP11-20	PASSENGER DOOR SWITCH	GROUND (DOOR OPEN)	B+

### SECURITY AND LOCKING CONTROL MODULE

Pin	Description	Active	Inactive
O BT40-1	TRUNK RELEASE SOLENOID	B+	GROUND
O BT40-2	FUEL FILLER FLAP SOLENOID	B+	GROUND
S BT40-8	SCP NETWORK	2 – 1600 Hz	
I BT40-13	GROUND	GROUND	GROUND
I BT40-14	GROUND	GROUND	GROUND
I BT40-15	BATTERY POWER SUPPLY	B+	B+
S BT40-16	SCP NETWORK	2 – 1600 Hz	
I BT41-5	TRUNK SWITCH	GROUND	B+
I BT41-6	EXTERNAL TRUNK RELEASE	GROUND (MOMENTARY)	B+
I BT41-7	PASSENGER DOOR LOCK ACTUATOR LOCK STATUS	GROUND (LOCKED)	B+
I BT41-19	DRIVER DOOR LOCK ACTUATOR LOCK STATUS	GROUND (LOCKED)	B+
I RH20-1	KEY FOB ANTENNA		
I RH20-2	KEY FOB ANTENNA SHIELD	GROUND	GROUND

**NOTE:** Refer to the Appendix at the rear of this book for CAN and SCP Network Messages.

The following abbreviations are used to represent values for Control Module Pin-Out data

I	Input	SG	Sensor Ground	S	SCP Network	V	Voltage (DC)
O	Output	A	ACP Network	D	Serial and Encoded Data	Hz	Frequency
SS	Sensor Supply V	C	CAN (Network)	B+	Battery Voltage	kHz	Frequency x 1000

**CAUTION:** The information on this data page is furnished to aid the user in understanding circuit operation. THIS INFORMATION SHOULD BE USED FOR REFERENCE ONLY.

**NOTE:** The values listed are approximately those that can be expected at the control module connector pins with all circuit connections made and all components connected and fitted. “Active” means a load is applied or a switch is ON; “Inactive” means a load is not applied or a switch is OFF.

**Fig. 13.1**

### COMPONENTS

Component	Connector / Type / Color	Location / Access
BODY PROCESSOR MODULE	FC14 / 104-WAY AMP EEEC / GREY	PASSENGER SIDE FASCIA / AIRBAG BRACKET
DOOR CONTROL MODULE – DRIVER	DD10 / 22-WAY FORD 2.8 TIMER / BLUE DD11 / 22-WAY FORD 2.8 TIMER / BLACK	DRIVER DOOR / DOOR CASING
DOOR CONTROL MODULE – PASSENGER	DP10 / 22-WAY FORD 2.8 TIMER / BLUE DP11 / 22-WAY FORD 2.8 TIMER / BLACK	PASSENGER DOOR / DOOR CASING
DOOR LOCK ACTUATOR – DRIVER	DD3 / 13-WAY ECONOSEAL III LC / BLACK	DRIVER DOOR / DOOR CASING
DOOR LOCK ACTUATOR – PASSENGER	DP3 / 13-WAY ECONOSEAL III LC / BLACK	PASSENGER DOOR / DOOR CASING
DOOR LOCK SWITCH – PASSENGER	DP3 / 13-WAY ECONOSEAL III LC / BLACK	PASSENGER DOOR / DOOR CASING
DOOR LOCK SWITCHES – DRIVER	DD3 / 13-WAY ECONOSEAL III LC / BLACK	DRIVER DOOR / DOOR CASING
DOOR SWITCH – DRIVER	DD3 / 13-WAY ECONOSEAL III LC / BLACK	DRIVER DOOR / DOOR CASING
DOOR SWITCH – PASSENGER	DP3 / 13-WAY ECONOSEAL III LC / BLACK	PASSENGER DOOR / DOOR CASING
EXTERNAL TRUNK RELEASE SWITCH	BL2 / 2-WAY MULTILOCK 070 / WHITE	TRUNK LID / LINER
FUEL FILL FLAP SOLENOID	IC24 / 2-WAY LABINAL / NATURAL	TRUNK / FUEL FILL
IGNITION SWITCH (KEY-IN SWITCH)	FC4 / 8-WAY MULTILOCK 070 / WHITE	STEERING COLUMN
KEY FOB ANTENNA (CONVERTIBLE)	HARD WIRED	TOP OF BACKLIGHT
KEY FOB ANTENNA (COUPE)	RH7 / COAXIAL CONNECTOR	TOP OF BACKLIGHT
NOT-IN-PARK MICROSWITCH	FC87 / 3-WAY MULTILOCK 070 / WHITE	GEAR SELECTOR ASSEMBLY
SECURITY AND LOCKING CONTROL MODULE	BT40 / 16-WAY FORD 2.8 TIMER / BLACK BT41 / 26-WAY FORD IDC / BLACK BT42 / 10-WAY FORD 2.8 TIMER / BLACK RH20 / COAXIAL CONNECTOR	TRUNK / ELECTRICAL CARRIER
TRUNK AND FUEL FILL RELEASE SWITCH	FC41 / 10-WAY AMP MQL / NATURAL	FASCIA / DRIVER SIDE
TRUNK RELEASE SOLENOID	BT43 / 2-WAY LABINAL / BROWN	TRUNK / LEFT HAND SIDE
TRUNK SWITCH	BT46 / 2-WAY AUGAT 1.6 / BLACK	TRUNK
VALET SWITCH	FC67 / 10-WAY AMP MQL / BLACK	DRIVER KNEE BOLSTER

### RELAYS

Relay	Color / Stripe	Connector / Color	Location / Access
DOOR LOCKING RELAY	BLACK	FC24 / BLACK	RH FASCIA RELAYS

### HARNESSTO-HARNESSTO CONNECTORS

Connector	Type / Color	Location / Access
AC13	20-WAY MULTILOCK 070 / YELLOW	FASCIA BOTTOM CONNECTOR MOUNTING BRACKET / RIGHT HAND SIDE
AC14	14-WAY MULTILOCK 070 / GREY	FASCIA BOTTOM CONNECTOR MOUNTING BRACKET / RIGHT HAND SIDE
AC15	20-WAY MULTILOCK 070 / GREY	FASCIA BOTTOM CONNECTOR MOUNTING BRACKET / RIGHT HAND SIDE
BB1	4-WAY MULTILOCK 070 / WHITE	TRUNK / ABOVE RIGHT HAND REAR WHEEL ARCH
BL1	4-WAY MULTILOCK 070 / WHITE	TRUNK / ABOVE RIGHT HAND REAR WHEEL ARCH
BT1	20-WAY MULTILOCK 070 / WHITE	TRUNK / ABOVE RIGHT HAND REAR WHEEL ARCH
BT2	20-WAY MULTILOCK 070 / WHITE	TRUNK / ABOVE RIGHT HAND REAR WHEEL ARCH
DD1	23-WAY AMP – FORD / BLACK	DRIVER SIDE ‘A’ POST MOUNTING BRACKET / ‘A’ POST TRIM
DP1	23-WAY AMP – FORD / BLACK	PASSENGER SIDE ‘A’ POST / ‘A’ POST TRIM
IC4	4-WAY MULTILOCK 070 / WHITE	TRUNK / LEFT OF ANTENNA ASSEMBLY
RH2	20-WAY MULTILOCK 070 / WHITE	REAR OF CENTER CONSOLE ASSEMBLY

### GROUNDS

Ground	Location / Type
BT1AL	EYELET (PAIR) – LEFT HAND LEG / ADJACENT TO BATTERY
BT1AR	EYELET (PAIR) – RIGHT HAND LEG / ADJACENT TO BATTERY
FC2AR	EYELET (PAIR) – RIGHT HAND LEG / RIGHT HAND ‘A’ POST
FC2BL	EYELET (PAIR) – LEFT HAND LEG / RIGHT HAND ‘A’ POST
FC2BR	EYELET (PAIR) – RIGHT HAND LEG / RIGHT HAND ‘A’ POST
FC3BL	EYELET (PAIR) – LEFT HAND LEG / TRANSMISSION TUNNEL, LEFT HAND SIDE
FC3BR	EYELET (PAIR) – RIGHT HAND LEG / TRANSMISSION TUNNEL, LEFT HAND SIDE
FC4AR	EYELET (PAIR) – RIGHT HAND LEG / LEFT HAND ‘A’ POST
FC4BL	EYELET (PAIR) – LEFT HAND LEG / LEFT HAND ‘A’ POST
FC4BR	EYELET (PAIR) – RIGHT HAND LEG / LEFT HAND ‘A’ POST
RH3S	EYELET (SINGLE) / ROOF, ADJACENT TO BACKLIGHT

**FOR CONTROL MODULE PIN OUT INFORMATION, UNFOLD PAGE TO LEFT.**

Refer to the front of this book for detailed information and illustrations regarding the location and identification of harnesses, relays, grounds, control modules and control module pins.



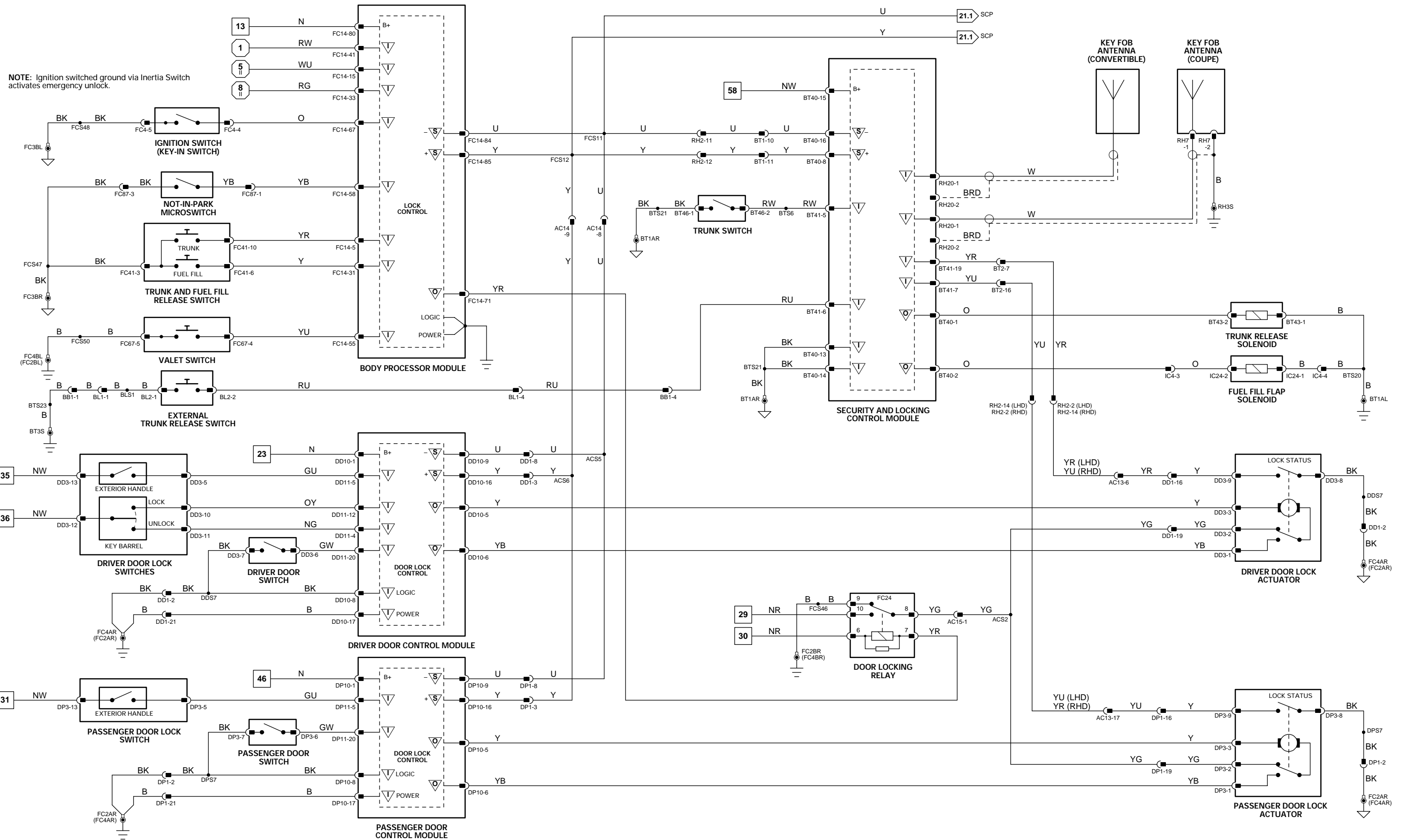

1 → 7 Fig. 01.1    1 → 5 Fig. 01.1    8 → 50 Fig. 01.2    51 → 90 Fig. 01.3    6 → 58 Fig. 01.4    59 → 73 Fig. 01.5    1 → 18 Fig. 02.1

▽ Input    + Sensor Supply V    ▽ ACP    S SCP  
 ▽ Output    ▽ Sensor Ground    ▽ C CAN    D Serial and Encoded Data

**VARIANT:** All Vehicles  
**VIN RANGE:** A11051 →  
**DATE OF ISSUE:** September 2000

## CONTROL MODULE PIN OUT INFORMATION

### BODY PROCESSOR MODULE

Pin	Description	Active	Inactive
D	FC14-13	ACTIVE SECURITY SOUNDER	ENCODED COMMUNICATIONS
O	FC14-22	PASSIVE SECURITY SOUNDER	AUDIO OUTPUT
O	FC14-23	PASSIVE SECURITY SOUNDER	AUDIO OUTPUT
O	FC14-29	SECURITY STATUS LED	B+ (PULSED)
I	FC14-32	IGNITION SWITCHED GROUND SUPPLY	GROUND
D	FC14-39	ENCODED COMMUNICATIONS	GROUND
I	FC14-41	IGNITION SWITCH SUPPLY	GROUND
I	FC14-55	VALET SWITCH	GROUND (MOMENTARY)
I	FC14-56	ENGINE COMPARTMENT SECURITY SWITCH	GROUND (HOOD OPEN)
O	FC14-70	HORN RELAY ACTIVATE	GROUND (HORN SOUNDING)
I	FC14-80	BATTERY POWER SUPPLY (LOGIC)	B+
S	FC14-84	SCP NETWORK	2 – 1600 Hz
S	FC14-85	SCP NETWORK	2 – 1600 Hz
D	FC14-92	ENCODED COMMUNICATIONS	
I	FC14-104	LIGHTING / MOTORS BATTERY POWER SUPPLY	B+

### DRIVER DOOR CONTROL MODULE

Pin	Description	Active	Inactive
I	DD10-1	BATTERY POWER SUPPLY	B+
I	DD10-8	LOGIC GROUND	GROUND
S	DD10-9	SCP NETWORK	2 – 1600 Hz
S	DD10-16	SCP NETWORK	2 – 1600 Hz
I	DD10-17	POWER GROUND	GROUND
I	DD11-4	DRIVER DOOR LOCK BARREL UNLOCK REQUEST	B+ (MOMENTARY)
I	DD11-12	DRIVER DOOR LOCK BARREL LOCK REQUEST	B+ (MOMENTARY)
I	DD11-20	DRIVER DOOR SWITCH	GROUND (DOOR OPEN)

### ENGINE CONTROL MODULE

Pin	Description	Active	Inactive
D	EM82-15	OK TO START	ENCODED COMMUNICATIONS
D	EM82-16	SECURITY ACKNOWLEDGE	ENCODED COMMUNICATIONS

### KEY TRANSPONDER MODULE

Pin	Description	Active	Inactive
I	FC22-1	GLASS BREAKAGE SENSOR	GROUND
I	FC22-4	BATTERY POWER SUPPLY	B+
D	FC22-6	SERIAL COMMUNICATION (ENCODED COMMUNICATION)	
D	FC22-7	READER / EXCITER COIL (ENCODED COMMUNICATION)	
D	FC22-8	READER / EXCITER COIL (ENCODED COMMUNICATION)	
D	FC22-9	GLASS BREAKAGE / OK TO START (ENCODED COMMUNICATION)	
I	FC22-12	GROUND	GROUND
I	FC22-13	IGNITION SWITCHED GROUND	GROUND
I	FC22-14	IGNITION SWITCHED GROUND	GROUND
D	FC22-16	OK TO START (ENCODED COMMUNICATION)	
D	FC22-17	SECURITY ACKNOWLEDGE (ENCODED COMMUNICATION)	

### MAJOR INSTRUMENT PACK

Pin	Description	Active	Inactive
S	FC25-13	SCP NETWORK	2 – 1600 Hz
S	FC25-14	SCP NETWORK	2 – 1600 Hz

### PASSENGER DOOR CONTROL MODULE

Pin	Description	Active	Inactive
I	DP10-1	BATTERY POWER SUPPLY	B+
I	DP10-8	LOGIC GROUND	GROUND
S	DP10-9	SCP NETWORK	2 – 1600 Hz
S	DP10-16	SCP NETWORK	2 – 1600 Hz
I	DP10-17	POWER GROUND	GROUND
I	DP11-20	PASSENGER DOOR SWITCH	GROUND (DOOR OPEN)

### SECURITY AND LOCKING CONTROL MODULE

Pin	Description	Active	Inactive
S	BT40-8	SCP NETWORK	2 – 1600 Hz
I	BT40-13	GROUND	GROUND
I	BT40-14	GROUND	GROUND
I	BT40-15	BATTERY POWER SUPPLY	B+
S	BT40-16	SCP NETWORK	2 – 1600 Hz
I	BT41-5	TRUNK SWITCH	GROUND
I	BT41-8	INCLINATION SENSOR TRIGGER	GROUND (MOMENTARY)
I	BT41-10	GROUND	GROUND
O	BT41-26	INCLINATION SENSOR SUPPLY	B+
I	RH20-1	KEY FOB ANTENNA	
I	RH20-2	KEY FOB ANTENNA SHIELD	GROUND

**NOTE:** Refer to the Appendix at the rear of this book for CAN and SCP Network Messages.

The following abbreviations are used to represent values for Control Module Pin-Out data

I	Input	SG	Sensor Ground	S	SCP Network	V	Voltage (DC)
O	Output	A	ACP Network	D	Serial and Encoded Data	Hz	Frequency
SS	Sensor Supply V	C	CAN (Network)	B+	Battery Voltage	kHz	Frequency x 1000

**CAUTION:** The information on this data page is furnished to aid the user in understanding circuit operation. THIS INFORMATION SHOULD BE USED FOR REFERENCE ONLY.

**NOTE:** The values listed are approximately those that can be expected at the control module connector pins with all circuit connections made and all components connected and fitted. “Active” means a load is applied or a switch is ON; “Inactive” means a load is not applied or a switch is OFF.

**Fig. 13.2**

### COMPONENTS

Component	Connector / Type / Color	Location / Access
ACTIVE SECURITY SOUNDER	LF18 / 6-WAY ECONOSEAL III LC / BLACK	REARWARD OF RIGHT FRONT HEADLAMP
BODY PROCESSOR MODULE	FC14 / 104-WAY AMP EEEC / GREY	PASSENGER SIDE FASCIA / AIRBAG BRACKET
DOOR CONTROL MODULE – DRIVER	DD10 / 22-WAY FORD 2.8 TIMER / BLUE DD11 / 22-WAY FORD 2.8 TIMER / BLACK	DRIVER DOOR / DOOR CASING
DOOR CONTROL MODULE – PASSENGER	DP10 / 22-WAY FORD 2.8 TIMER / BLUE DP11 / 22-WAY FORD 2.8 TIMER / BLACK	PASSENGER DOOR / DOOR CASING
DOOR LOCK SWITCHES – DRIVER	DD3 / 13-WAY ECONOSEAL III LC / BLACK	DRIVER DOOR / DOOR CASING
DOOR SWITCH – DRIVER	DD3 / 13-WAY ECONOSEAL III LC / BLACK	DRIVER DOOR / DOOR CASING
DOOR SWITCH – PASSENGER	DP3 / 13-WAY ECONOSEAL III LC / BLACK	PASSENGER DOOR / DOOR CASING
ENGINE COMPARTMENT SECURITY SWITCH	EM34 / 2-WAY ECONOSEAL 3 LC / BLACK	ENGINE COMPARTMENT / RIGHT HAND HOOD LATCH
ENGINE CONTROL MODULE	EM80 / 31-WAY AMP 403 / NATURAL EM81 / 24-WAY AMP 403 / NATURAL EM82 / 17-WAY AMP 403 / NATURAL EM83 / 28-WAY AMP 403 / NATURAL EM84 / 22-WAY AMP 403 / NATURAL EM85 / 12-WAY MULTILOCK 070 / WHITE	ENGINE COMPARTMENT / CONTROL MODULE ENCLOSURE
FUSE BOX – ENGINE COMPARTMENT	LF5 / 10-WAY U.T.A. FUSEBOX / NATURAL LF6 / 10-WAY U.T.A. FUSEBOX / BLACK LF7 / 10-WAY U.T.A. FUSEBOX / GREEN LF8 / 10-WAY U.T.A. FUSEBOX / BLUE LF70 / EYELET	ENGINE COMPARTMENT / LEFT FRONT
GLASS BREAKAGE SENSOR (ROOF CONSOLE)	RF10 / 6-WAY MULTILOCK 070 / GREY	ROOF CONSOLE
HORN – LH	LF16 / LUCAR POSILOCK / BLACK LF17 / LUCAR POSILOCK / BLACK	FRONT BUMPER / REAR
HORN – RH	LF14 / LUCAR POSILOCK / BLACK LF15 / LUCAR POSILOCK / BLACK	FRONT BUMPER / REAR
INCLINATION SENSOR	IS1 / INCLINATION SENSOR CONNECTOR / ORANGE	TRUNK / ADJACENT TO ANTENNA
KEY FOB ANTENNA (CONVERTIBLE)	HARD WIRED	TOP OF BACKLIGHT
KEY FOB ANTENNA (COUPE)	RH7 / COAXIAL CONNECTOR	TOP OF BACKLIGHT
KEY TRANSPONDER MODULE	FC22 / 20-WAY MULTILOCK 040 / GREEN	ADJACENT TO DRIVER SIDE FUSE BOX
MAJOR INSTRUMENT PACK	FC25 / 26-WAY AMP MICRO QUAD LOCK / BLACK FC26 / 26-WAY AMP MICRO QUAD LOCK / YELLOW	FASCIA
PASSIVE SECURITY SOUNDER	LF18 / 6-WAY ECONOSEAL III LC / BLACK	ENGINE COMPARTMENT / RIGHT HAND SIDE
READER / EXCITER COIL (COLUMN SWITCHGEAR)	SC12 / 3-WAY MULTILOCK 070 / WHITE	STEERING COLUMN / RIGHT HAND SIDE
SECURITY ACTIVE INDICATOR (GEAR SELECTOR ILLUMINATION MODULE)	FC88 / 10-WAY MULTILOCK 070 / WHITE	FRONT OF GEAR SELECTOR MODULE
SECURITY AND LOCKING CONTROL MODULE	BT40 / 16-WAY FORD 2.8 TIMER / BLACK BT41 / 26-WAY FORD IDC / BLACK BT42 / 10-WAY FORD 2.8 TIMER / BLACK RH20 / COAXIAL CONNECTOR	TRUNK / ELECTRICAL CARRIER
TRUNK SWITCH	BT46 / 2-WAY AUGAT 1.6 / BLACK	TRUNK
VALET SWITCH	FC67 / 10-WAY AMP MQL / BLACK	DRIVER KNEE BOLSTER

### RELAYS

Relay	Color / Stripe	Connector / Color	Location / Access
HORN RELAY (#6)	BROWN	BUS	ENGINE COMPARTMENT FUSE BOX

### HARNESS-TO-HARNESS CONNECTORS

Connector	Type / Color	Location / Access
AC14	14-WAY MULTILOCK 070 / GREY	FASCIA BOTTOM CONNECTOR MOUNTING BRACKET / RIGHT HAND SIDE
BT1	20-WAY MULTILOCK 070 / WHITE	TRUNK / ABOVE RIGHT HAND REAR WHEEL ARCH
BT47	3-WAY MULTILOCK 070 / WHITE	TRUNK / ADJACENT TO ANTENNA
DD1	23-WAY AMP – FORD / BLACK	DRIVER SIDE ‘A’ POST MOUNTING BRACKET / ‘A’ POST TRIM
DP1	23-WAY AMP – FORD / BLACK	PASSENGER SIDE ‘A’ POST / ‘A’ POST TRIM
EM2	18-WAY MULTILOCK 070 / YELLOW	ENGINE COMPARTMENT / ADJACENT TO RIGHT HAND ENCLOSURE
EM3	14-WAY MULTILOCK 070 / GREY	ENGINE COMPARTMENT / ADJACENT TO RIGHT HAND ENCLOSURE
LF1	20-WAY MULTILOCK 070 / GREY	LEFT HAND ‘A’ POST CONNECTOR MOUNTING BRACKET / ‘A’ POST TRIM
LF60	20-WAY MULTILOCK 070 / WHITE	LEFT HAND ‘A’ POST CONNECTOR MOUNTING BRACKET / ‘A’ POST TRIM
RF1	24-WAY CONNECTOR / BLACK	RIGHT HAND ‘A’ POST CONNECTOR MOUNTING BRACKET / ‘A’ POST TRIM
RF5	8-WAY MULTILOCK 070 / WHITE	LOWER RH ‘A’ POST / ‘A’ POST TRIM
RF5	8-WAY MULTILOCK 070 / WHITE	LOWER RH ‘A’ POST / ‘A’ POST TRIM
SC1	12-WAY MULTILOCK 070 / WHITE	RIGHT HAND SIDE OF STEERING COLUMN

### GROUNDS

Ground	Location / Type
BT1AR	EYELET (PAIR) – RIGHT HAND LEG / ADJACENT TO BATTERY
EM1BR	EYELET (PAIR) – RIGHT HAND LEG / ENGINE COMPARTMENT, RIGHT HAND ENCLOSURE
EM1BS	EYELET (SINGLE) / ENGINE COMPARTMENT, RIGHT HAND ENCLOSURE
EM2BR	EYELET (PAIR) – RIGHT HAND LEG / ENGINE COMPARTMENT, LEFT HAND ENCLOSURE
EM2BS	EYELET (SINGLE) / ENGINE COMPARTMENT, LEFT HAND ENCLOSURE
FC2AR	EYELET (PAIR) – RIGHT HAND LEG / RIGHT HAND ‘A’ POST
FC2BL	EYELET (PAIR) – LEFT HAND LEG / RIGHT HAND ‘A’ POST
FC3BR	EYELET (PAIR) – RIGHT HAND LEG / TRANSMISSION TUNNEL, LEFT HAND SIDE
FC4AR	EYELET (PAIR) – RIGHT HAND LEG / LEFT HAND ‘A’ POST
FC4BL	EYELET (PAIR) – LEFT HAND LEG / LEFT HAND ‘A’ POST
LF1AL	EYELET (PAIR) – LEFT HAND LEG / RIGHT HAND HEADLAMP
LF2BR	EYELET (PAIR) – RIGHT HAND LEG / ENGINE COMPARTMENT, FORWARD OF LEFT HAND HOOD CATCH
RH3S	EYELET (SINGLE) / ROOF, ADJACENT TO BACKLIGHT

FOR CONTROL MODULE PIN OUT INFORMATION, UNFOLD PAGE TO LEFT.

Refer to the front of this book for detailed information and illustrations regarding the location and identification of harnesses, relays, grounds, control modules and control module pins.

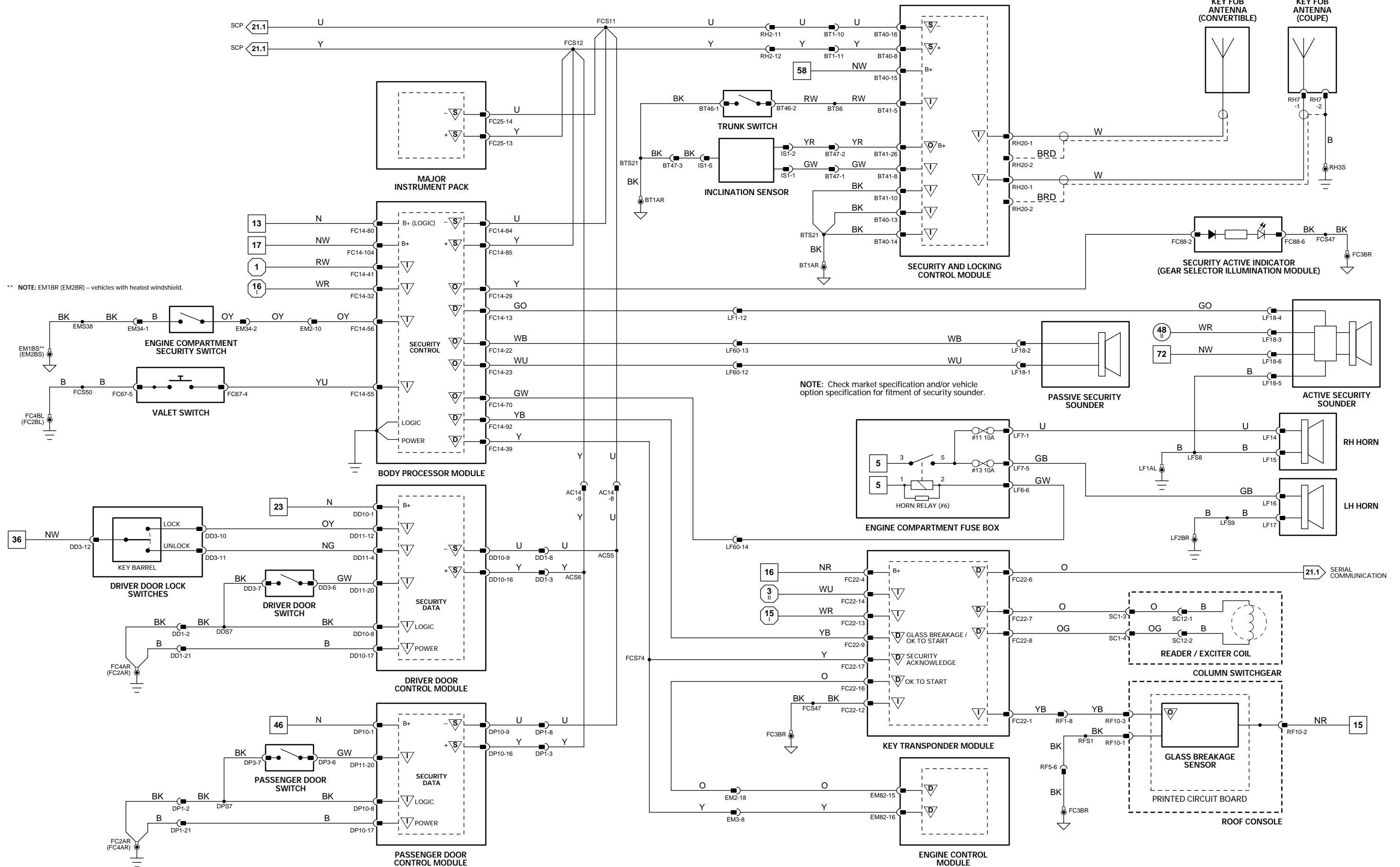

\*\* NOTE: EM1BR (EM2BR) - vehicles with heated windshield.

NOTE: Check market specification and/or vehicle option specification for fitment of security sounder.

**CONTROL MODULE PIN OUT INFORMATION**

**BODY PROCESSOR MODULE**

Pin	Description	Active	Inactive
O FC14-22	PASSIVE SECURITY SOUNDER	AUDIO OUTPUT	
O FC14-23	PASSIVE SECURITY SOUNDER	AUDIO OUTPUT	
O FC14-29	SECURITY STATUS LED	B+ (PULSED)	GROUND
I FC14-32	IGNITION SWITCHED GROUND SUPPLY	GROUND	GROUND
D FC14-39	ENCODED COMMUNICATIONS		
I FC14-41	IGNITION GROUND SUPPLY	GROUND	
I FC14-55	VALET SWITCH	GROUND (MOMENTARY)	B+
I FC14-56	ENGINE COMPARTMENT SECURITY SWITCH	GROUND (HOOD OPEN)	B+
O FC14-70	HORN RELAY ACTIVATE	GROUND (HORN SOUNDING)	B+
I FC14-80	BATTERY POWER SUPPLY (LOGIC)	B+	B+
S FC14-84	SCP NETWORK	2 – 1600 Hz	
S FC14-85	SCP NETWORK	2 – 1600 Hz	
I FC14-104	LIGHTING / MOTORS BATTERY POWER SUPPLY	B+	B+

**DRIVER DOOR CONTROL MODULE**

Pin	Description	Active	Inactive
I DD10-1	BATTERY POWER SUPPLY	B+	B+
I DD10-8	LOGIC GROUND	GROUND	GROUND
S DD10-9	SCP NETWORK	2 – 1600 Hz	
S DD10-16	SCP NETWORK	2 – 1600 Hz	
I DD10-17	POWER GROUND	GROUND	GROUND
I DD11-4	DRIVER DOOR LOCK BARREL UNLOCK REQUEST	B+ (MOMENTARY)	GROUND
I DD11-12	DRIVER DOOR LOCK BARREL LOCK REQUEST	B+ (MOMENTARY)	GROUND
I DD11-20	DRIVER DOOR SWITCH	GROUND (DOOR OPEN)	B+

**ENGINE CONTROL MODULE**

Pin	Description	Active	Inactive
D EM82-15	OK TO START	ENCODED COMMUNICATIONS	
D EM82-16	SECURITY ACKNOWLEDGE	ENCODED COMMUNICATIONS	

**KEY TRANSPONDER MODULE**

Pin	Description	Active	Inactive
I FC22-4	BATTERY POWER SUPPLY	B+	B+
D FC22-6	SERIAL COMMUNICATION (ENCODED COMMUNICATION)		
D FC22-7	READER / EXCITER COIL (ENCODED COMMUNICATION)		
D FC22-8	READER / EXCITER COIL (ENCODED COMMUNICATION)		
I FC22-12	GROUND	GROUND	GROUND
I FC22-13	IGNITION SWITCHED GROUND	GROUND	
I FC22-14	IGNITION SWITCHED GROUND	GROUND	
D FC22-16	OK TO START (ENCODED COMMUNICATION)		
D FC22-17	SECURITY ACKNOWLEDGE (ENCODED COMMUNICATION)		

**MAJOR INSTRUMENT PACK**

Pin	Description	Active	Inactive
S FC25-13	SCP NETWORK	2 – 1600 Hz	
S FC25-14	SCP NETWORK	2 – 1600 Hz	

**PASSENGER DOOR CONTROL MODULE**

Pin	Description	Active	Inactive
I DP10-1	BATTERY POWER SUPPLY	B+	B+
I DP10-8	LOGIC GROUND	GROUND	GROUND
S DP10-9	SCP NETWORK	2 – 1600 Hz	
S DP10-16	SCP NETWORK	2 – 1600 Hz	
I DP10-17	POWER GROUND	GROUND	GROUND
I DP11-20	PASSENGER DOOR SWITCH	GROUND (DOOR OPEN)	B+

**SECURITY AND LOCKING CONTROL MODULE**

Pin	Description	Active	Inactive
S BT40-8	SCP NETWORK	2 – 1600 Hz	
I BT40-13	GROUND	GROUND	GROUND
I BT40-14	GROUND	GROUND	GROUND
I BT40-15	BATTERY POWER SUPPLY	B+	B+
S BT40-16	SCP NETWORK	2 – 1600 Hz	
I BT41-5	TRUNK SWITCH	GROUND	B+
I BT41-10	GROUND	GROUND	GROUND
I RH20-1	KEY FOB ANTENNA		GROUND
I RH20-2	KEY FOB ANTENNA SHIELD	GROUND	GROUND

**NOTE:** Refer to the Appendix at the rear of this book for CAN and SCP Network Messages.

The following abbreviations are used to represent values for Control Module Pin-Out data

<b>I</b> Input	<b>SG</b> Sensor Ground	<b>S</b> SCP Network	<b>V</b> Voltage (DC)
<b>O</b> Output	<b>A</b> ACP Network	<b>D</b> Serial and Encoded Data	<b>Hz</b> Frequency
<b>SS</b> Sensor Supply V	<b>C</b> CAN (Network)	<b>B+</b> Battery Voltage	<b>kHz</b> Frequency x 1000

**CAUTION:** The information on this data page is furnished to aid the user in understanding circuit operation. THIS INFORMATION SHOULD BE USED FOR REFERENCE ONLY.

**NOTE:** The values listed are approximately those that can be expected at the control module connector pins with all circuit connections made and all components connected and fitted. “Active” means a load is applied or a switch is ON; “Inactive” means a load is not applied or a switch is OFF.

**Fig. 13.3**

**COMPONENTS**

Component	Connector / Type / Color	Location / Access
BODY PROCESSOR MODULE	FC14 / 104-WAY AMP EEEC / GREY	PASSENGER SIDE FASCIA / AIRBAG BRACKET
DOOR CONTROL MODULE – DRIVER	DD10 / 22-WAY FORD 2.8 TIMER / BLUE DD11 / 22-WAY FORD 2.8 TIMER / BLACK DP10 / 22-WAY FORD 2.8 TIMER / BLUE DP11 / 22-WAY FORD 2.8 TIMER / BLACK	DRIVER DOOR / DOOR CASING  PASSENGER DOOR / DOOR CASING
DOOR CONTROL MODULE – PASSENGER	DD3 / 13-WAY ECONOSEAL III LC / BLACK DD3 / 13-WAY ECONOSEAL III LC / BLACK DD3 / 13-WAY ECONOSEAL III LC / BLACK DP3 / 13-WAY ECONOSEAL III LC / BLACK	DRIVER DOOR / DOOR CASING DRIVER DOOR / DOOR CASING PASSENGER DOOR / DOOR CASING
DOOR LOCK SWITCHES – DRIVER	EM34 / 2-WAY ECONOSEAL 3 LC / BLACK	ENGINE COMPARTMENT / RIGHT HAND HOOD LATCH
DOOR SWITCH – DRIVER	EM80 / 31-WAY AMP 403 / NATURAL	ENGINE COMPARTMENT / CONTROL MODULE ENCLOSURE
DOOR SWITCH – PASSENGER	EM81 / 24-WAY AMP 403 / NATURAL	
ENGINE COMPARTMENT SECURITY SWITCH	EM82 / 17-WAY AMP 403 / NATURAL	
ENGINE CONTROL MODULE	EM83 / 28-WAY AMP 403 / NATURAL EM84 / 22-WAY AMP 403 / NATURAL EM85 / 12-WAY MULTILOCK 070 / WHITE	
FUSE BOX – ENGINE COMPARTMENT	LF5 / 10-WAY U.T.A. FUSEBOX / NATURAL LF6 / 10-WAY U.T.A. FUSEBOX / BLACK LF7 / 10-WAY U.T.A. FUSEBOX / GREEN LF8 / 10-WAY U.T.A. FUSEBOX / BLUE LF70 / EYELET	ENGINE COMPARTMENT / LEFT FRONT
HORN – LH	LF16 / LUCAR POSILOCK / BLACK LF17 / LUCAR POSILOCK / BLACK	FRONT BUMPER / REAR
HORN – RH	LF14 / LUCAR POSILOCK / BLACK LF15 / LUCAR POSILOCK / BLACK	FRONT BUMPER / REAR
KEY FOB ANTENNA (CONVERTIBLE)	HARD WIRED	TOP OF BACKLIGHT
KEY FOB ANTENNA (COUPE)	RH7 / COAXIAL CONNECTOR	TOP OF BACKLIGHT
KEY TRANSPONDER MODULE	FC22 / 20-WAY MULTILOCK 040 / GREEN	ADJACENT TO DRIVER SIDE FUSE BOX
MAJOR INSTRUMENT PACK	FC25 / 26-WAY AMP MICRO QUAD LOCK / BLACK FC26 / 26-WAY AMP MICRO QUAD LOCK / YELLOW LF18 / 6-WAY ECONOSEAL III LC / BLACK SC12 / 3-WAY MULTILOCK 070 / WHITE	FASCIA  ENGINE COMPARTMENT / RIGHT HAND SIDE STEERING COLUMN / RIGHT HAND SIDE ROOF CONSOLE
PASSIVE SECURITY SOUNDER	RF11 / HYBRID / WHITE	
READER / EXCITER COIL (COLUMN SWITCHGEAR)	RF10 / 6-WAY MULTILOCK 070 / GREY	FRONT OF GEAR SELECTOR MODULE
ROOF CONSOLE	FC88 / 10-WAY MULTILOCK 070 / WHITE	
SECURITY ACTIVE INDICATOR (GEAR SELECTOR ILLUMINATION MODULE)	BT40 / 16-WAY FORD 2.8 TIMER / BLACK BT41 / 26-WAY FORD IDC / BLACK BT42 / 10-WAY FORD 2.8 TIMER / BLACK RH20 / COAXIAL CONNECTOR	TRUNK / ELECTRICAL CARRIER
SECURITY AND LOCKING CONTROL MODULE	BT46 / 2-WAY AUGAT 1.6 / BLACK FC67 / 10-WAY AMP MQL / BLACK	TRUNK DRIVER KNEE BOLSTER

**RELAYS**

Relay	Color / Stripe	Connector / Color	Location / Access
HORN RELAY (#6)	BROWN	BUS	ENGINE COMPARTMENT FUSE BOX

**HARNESS-TO-HARNESS CONNECTORS**

Connector	Type / Color	Location / Access
AC14	14-WAY MULTILOCK 070 / GREY	FASCIA BOTTOM CONNECTOR MOUNTING BRACKET / RIGHT HAND SIDE
BT1	20-WAY MULTILOCK 070 / WHITE	TRUNK / ABOVE RIGHT HAND REAR WHEEL ARCH
DD1	23-WAY AMP – FORD / BLACK	DRIVER SIDE ‘A’ POST MOUNTING BRACKET/ ‘A’ POST TRIM
DP1	23-WAY AMP – FORD / BLACK	PASSENGER SIDE ‘A’ POST / ‘A’ POST TRIM
EM2	18-WAY MULTILOCK 070 / YELLOW	PASSENGER SIDE ‘A’ POST / ‘A’ POST TRIM
EM3	14-WAY MULTILOCK 070 / GREY	ENGINE COMPARTMENT / ADJACENT TO RIGHT HAND ENCLOSURE
LF1	20-WAY MULTILOCK 070 / GREY	ENGINE COMPARTMENT / ADJACENT TO RIGHT HAND ENCLOSURE
LF60	20-WAY MULTILOCK 070 / WHITE	LEFT HAND ‘A’ POST CONNECTOR MOUNTING BRACKET / ‘A’ POST TRIM
RF1	24-WAY CONNECTOR / BLACK	LEFT HAND ‘A’ POST CONNECTOR MOUNTING BRACKET / ‘A’ POST TRIM
RF5	8-WAY MULTILOCK 070 / WHITE	RIGHT HAND ‘A’ POST CONNECTOR MOUNTING BRACKET / ‘A’ POST TRIM
RF5	8-WAY MULTILOCK 070 / WHITE	LOWER RH ‘A’ POST / ‘A’ POST TRIM
RF5	8-WAY MULTILOCK 070 / WHITE	LOWER RH ‘A’ POST / ‘A’ POST TRIM
RH2	20-WAY MULTILOCK 070 / WHITE	REAR OF CENTER CONSOLE ASSEMBLY

**GROUNDS**

Ground	Location / Type
BT1AR	EYELET (PAIR) – RIGHT HAND LEG / ADJACENT TO BATTERY
EM1BR	EYELET (PAIR) – RIGHT HAND LEG / ENGINE COMPARTMENT, RIGHT HAND ENCLOSURE
EM1BS	EYELET (SINGLE) / ENGINE COMPARTMENT, RIGHT HAND ENCLOSURE
EM2BR	EYELET (PAIR) – RIGHT HAND LEG / ENGINE COMPARTMENT, LEFT HAND ENCLOSURE
EM2BS	EYELET (SINGLE) / ENGINE COMPARTMENT, LEFT HAND ENCLOSURE
FC2AR	EYELET (PAIR) – RIGHT HAND LEG / RIGHT HAND ‘A’ POST
FC2BL	EYELET (PAIR) – LEFT HAND LEG / RIGHT HAND ‘A’ POST
FC3BR	EYELET (PAIR) – RIGHT HAND LEG / TRANSMISSION TUNNEL, LEFT HAND SIDE
FC4AR	EYELET (PAIR) – RIGHT HAND LEG / LEFT HAND ‘A’ POST
FC4BL	EYELET (PAIR) – LEFT HAND LEG / LEFT HAND ‘A’ POST
LF1AL	EYELET (PAIR) – LEFT HAND LEG / RIGHT HAND HEADLAMP
LF2BR	EYELET (PAIR) – RIGHT HAND LEG / ENGINE COMPARTMENT, FORWARD OF LEFT HAND HOOD CATCH
RH3S	EYELET (SINGLE) / ROOF, ADJACENT TO BACKLIGHT

FOR CONTROL MODULE PIN OUT INFORMATION, UNFOLD PAGE TO LEFT.

Refer to the front of this book for detailed information and illustrations regarding the location and identification of harnesses, relays, grounds, control modules and control module pins.

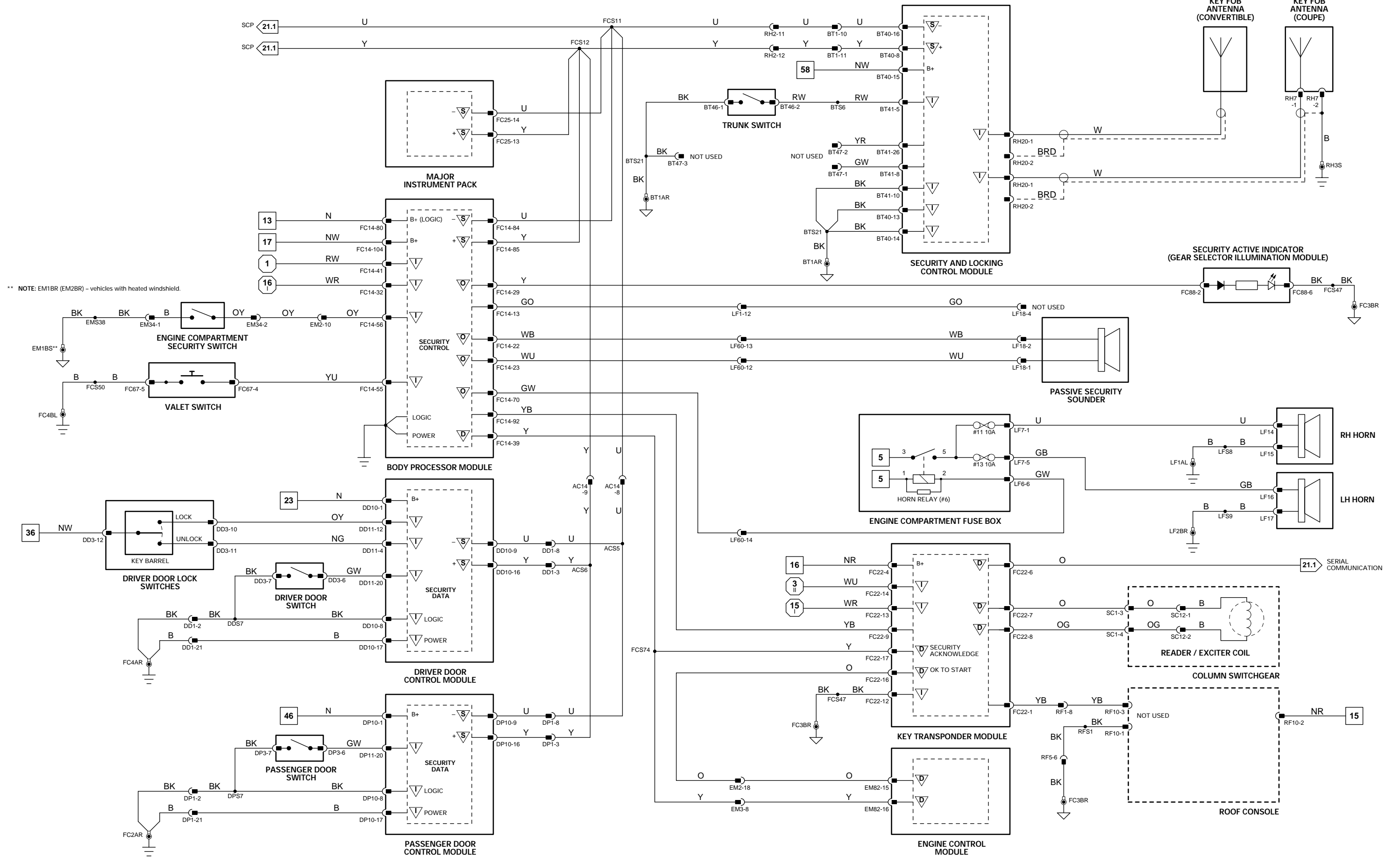

\*\* NOTE: EM1BR (EM2BR) - vehicles with heated windshield.

1 → 7 Fig. 01.1    1 → 5 Fig. 01.1    8 → 50 Fig. 01.2    51 → 90 Fig. 01.3    6 → 58 Fig. 01.4    59 → 73 Fig. 01.5    1 → 18 Fig. 02.1

Input    Sensor Supply V    ACP    SCP  
 Output    Sensor Ground    CAN    Serial and Encoded Data

VARIANT: NAS Vehicles  
 VIN RANGE: A11051 →  
 DATE OF ISSUE: September 2000

CONTROL MODULE PIN OUT INFORMATION

**Fig. 14.1**

**BODY PROCESSOR MODULE**

Pin	Description	Active	Inactive
I FC14-6	WASHER FLUID LEVEL LOW	0 V	B+
I FC14-9	INTERMITTENT WIPER REQUEST	GROUND (MOMENTARY)	B+
I FC14-15	IGNITION SWITCHED GROUND SUPPLY	GROUND	
I FC14-16	SIDE LAMP REQUEST	GROUND	B+
O FC14-18	POWERWASH RELAY ACTIVATE	GROUND	B+
O FC14-19	WIPER FAST / SLOW RELAY ACTIVATE	GROUND	B+
O FC14-26	WINDSHIELD WASH PUMP AND FLUID LEVEL SENSOR SUPPLY	B+	GROUND
I FC14-34	FAST WIPE REQUEST	GROUND	B+
I FC14-37	WASH REQUEST	0 V (MOMENTARY)	B+
O FC14-43	WIPER RUN / STOP RELAY ACTIVATE	GROUND	B+
I FC14-60	WIPER MOTOR PARK SWITCH	GROUND (PARKED)	B+ (NOT PARKED)
I FC14-80	BATTERY POWER SUPPLY (LOGIC)	B+	B+
I FC14-94	SLOW WIPE REQUEST	GROUND (WIPERS ON)	B+
I FC14-104	LIGHTING / MOTORS BATTERY POWER SUPPLY	B+	B+

**COMPONENTS**

Component	Connector / Type / Color	Location / Access
BODY PROCESSOR MODULE	FC14 / 104-WAY AMP EEEC / GREY	PASSENGER SIDE FASCIA / AIRBAG BRACKET
FUSE BOX - ENGINE COMPARTMENT	LF5 / 10-WAY U.T.A. FUSEBOX / NATURAL LF6 / 10-WAY U.T.A. FUSEBOX / BLACK LF7 / 10-WAY U.T.A. FUSEBOX / GREEN LF8 / 10-WAY U.T.A. FUSEBOX / BLUE LF70 / EYELET	ENGINE COMPARTMENT / LEFT FRONT
INTERIOR REAR VIEW MIRROR	RF2 / 6-WAY MULTILOCK 070 / YELLOW	WINDSHIELD / FORWARD OF ROOF CONSOLE
LIGHTING STALK (COLUMN SWITCHGEAR)	SC2 / 10-WAY MULTILOCK 070 / YELLOW	STEERING COLUMN
POWERWASH PUMP	LF25 / 2-WAY ECONOSEAL III HC / BLACK	LEFT FRONT FENDER / WHEEL ARCH LINER
RAIN SENSING MODULE	RS1 / 12-WAY AMP ML42 / BLACK	ABOVE PASSENGER FOOTWELL
RAIN SENSOR	RF15 / 3-WAY MICRO QUAD LOCK / BLACK	BEHIND REAR VIEW MIRROR
WASH / WIPE STALK (COLUMN SWITCHGEAR)	SC1 / 12-WAY MULTILOCK 070 / WHITE	STEERING COLUMN
WINDSHIELD WASH PUMP AND FLUID LEVEL SENSOR	LF27 / 3-WAY AUGAT 1.6 / BLACK	LEFT FRONT FENDER / WHEEL ARCH LINER
WIPER MOTOR	EM51 / 5-WAY FORD FAO / BLACK	BASE OF WINDSHIELD / AIR INTAKE PLENUM

**RELAYS**

Relay	Color / Stripe	Connector / Color	Location / Access
WIPER RUN / STOP RELAY	BLACK	LF48 / BLACK	LH ENCLOSURE RELAYS
WIPER FAST / SLOW RELAY	BLACK	LF49 / BLACK	LH ENCLOSURE RELAYS
POWERWASH RELAY (#4)	BROWN	BUS	ENGINE COMPARTMENT FUSE BOX

**HARNESS-TO-HARNESS CONNECTORS**

Connector	Type / Color	Location / Access
EM2	18-WAY MULTILOCK 070 / YELLOW	ENGINE COMPARTMENT / ADJACENT TO RIGHT HAND ENCLOSURE
FC49	12-WAY MULTILOCK 040 / BLACK	FASCIA
LF3	13-WAY ECONOSEAL III LC / WHITE	LHD: ENGINE COMPARTMENT / ADJACENT TO BRAKE SERVO RHD: ENGINE COMPARTMENT / CONTROL MODULE ENCLOSURE
LF1	20-WAY MULTILOCK 070 / GREY	LEFT HAND 'A' POST CONNECTOR MOUNTING BRACKET / 'A' POST TRIM
LF60	20-WAY MULTILOCK 070 / WHITE	LEFT HAND 'A' POST CONNECTOR MOUNTING BRACKET / 'A' POST TRIM
RF1	24-WAY CONNECTOR / BLACK	RIGHT HAND 'A' POST CONNECTOR MOUNTING BRACKET / 'A' POST TRIM

**GROUND**

Ground	Location / Type
FC3BL	EYELET (PAIR) - LEFT HAND LEG / TRANSMISSION TUNNEL, LEFT HAND SIDE
FC3BR	EYELET (PAIR) - RIGHT HAND LEG / TRANSMISSION TUNNEL, LEFT HAND SIDE
LF1AR	EYELET (PAIR) - RIGHT HAND LEG / RIGHT HAND HEADLAMP
LF3BS	EYELET (SINGLE) / ENGINE COMPARTMENT, FORWARD OF LEFT HAND HOOD CATCH

FOR CONTROL MODULE PIN OUT INFORMATION, UNFOLD PAGE TO LEFT.

The following abbreviations are used to represent values for Control Module Pin-Out data

I	Input	SG	Sensor Ground	S	SCP Network	V	Voltage (DC)
O	Output	A	ACP Network	D	Serial and Encoded Data	Hz	Frequency
SS	Sensor Supply V	C	CAN (Network)	B+	Battery Voltage	kHz	Frequency x 1000

CAUTION: The information on this data page is furnished to aid the user in understanding circuit operation. THIS INFORMATION SHOULD BE USED FOR REFERENCE ONLY.

NOTE: The values listed are approximately those that can be expected at the control module connector pins with all circuit connections made and all components connected and fitted. "Active" means a load is applied or a switch is ON; "Inactive" means a load is not applied or a switch is OFF.

Refer to the front of this book for detailed information and illustrations regarding the location and identification of harnesses, relays, grounds, control modules and control module pins.

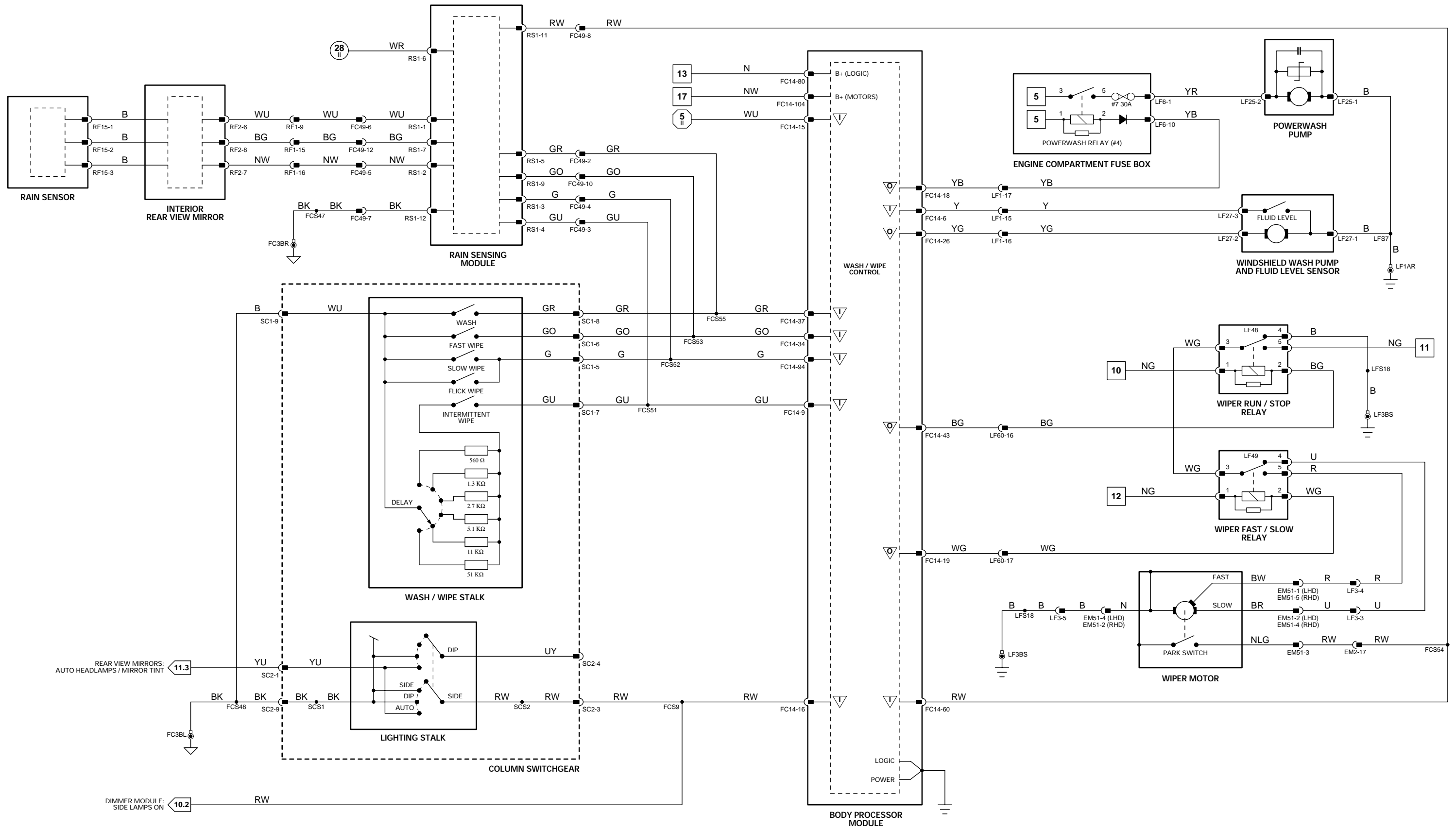

1 → 7 Fig. 01.1   
 1 → 5 Fig. 01.1   
 8 → 50 Fig. 01.2   
 51 → 90 Fig. 01.3   
 6 → 58 Fig. 01.4   
 59 → 73 Fig. 01.5   
 1 → 18 Fig. 02.1

▽ Input   
 + Sensor Supply V   
 △ ACP   
 S SCP  
▽ Output   
 ▽ Sensor Ground   
C CAN   
D Serial and Encoded Data

**VARIANT:** All Vehicles  
**VIN RANGE:** A11051 →  
**DATE OF ISSUE:** September 2000

## CONTROL MODULE PIN OUT INFORMATION

### BODY PROCESSOR MODULE

Pin	Description	Active	Inactive
S FC14-84	SCP NETWORK	2 – 1600 Hz	
S FC14-85	SCP NETWORK	2 – 1600 Hz	

### DRIVER DOOR CONTROL MODULE

Pin	Description	Active	Inactive
I DD10-1	BATTERY POWER SUPPLY	B+	B+
O DD10-7	WINDOW LIFT MOTOR DOWN SUPPLY	B+	GROUND
I DD10-8	LOGIC GROUND	GROUND	GROUND
S DD10-9	SCP NETWORK	2 – 1600 Hz	
I DD10-10	DRIVER SWITCH PACK LH WINDOW DOWN REQUEST	GROUND (MOMENTARY)	B+
I DD10-11	DRIVER WINDOW LIFT SENSOR FEEDBACK	2 V = UP; 12 V = DOWN	
I DD10-12	DRIVER WINDOW LIFT SENSOR FEEDBACK	2 V = UP; 12 V = DOWN	
O DD10-13	DRIVER WINDOW LIFT SENSOR REFERENCE VOLTAGE	B+	B+
O DD10-15	DRIVER WINDOW LIFT MOTOR UP SUPPLY	B+	GROUND
S DD10-16	SCP NETWORK	2 – 1600 Hz	
I DD10-17	POWER GROUND	GROUND	GROUND
I DD10-18	DRIVER SWITCH PACK LH WINDOW UP REQUEST	GROUND (MOMENTARY)	GROUND
I DD10-19	DRIVER SWITCH PACK RH WINDOW UP REQUEST	GROUND (MOMENTARY)	GROUND
I DD11-4	DRIVER DOOR LOCK BARREL UNLOCK REQUEST	B+ (MOMENTARY)	GROUND
I DD11-7	DRIVER SWITCH PACK RH WINDOW DOWN REQUEST	B+ (MOMENTARY)	GROUND
I DD11-12	DRIVER DOOR LOCK BARREL LOCK REQUEST	B+ (MOMENTARY)	GROUND

### MAJOR INSTRUMENT PACK

Pin	Description	Active	Inactive
S FC25-13	SCP NETWORK	2 – 1600 Hz	
S FC25-14	SCP NETWORK	2 – 1600 Hz	

### PASSENGER DOOR CONTROL MODULE

Pin	Description	Active	Inactive
I DP10-1	BATTERY POWER SUPPLY	B+	B+
O DP10-7	PASSENGER WINDOW LIFT MOTOR DOWN SUPPLY	B+	GROUND
I DP10-8	LOGIC GROUND	GROUND	GROUND
S DP10-9	SCP NETWORK	2 – 1600 Hz	
I DP10-10	PASSENGER SWITCH PACK RH WINDOW DOWN REQUEST	B+ (MOMENTARY)	GROUND
I DP10-11	PASSENGER WINDOW LIFT MOVEMENT SENSOR FEEDBACK	2 V = UP; 12 V = DOWN	
I DP10-12	PASSENGER WINDOW LIFT MOVEMENT SENSOR FEEDBACK	2 V = UP; 12 V = DOWN	
O DP10-13	PASSENGER WINDOW LIFT MOVEMENT SENSOR REFERENCE VOLTAGE	B+	B+
O DP10-15	PASSENGER WINDOW LIFT MOTOR UP SUPPLY	B+	GROUND
S DP10-16	SCP NETWORK	2 – 1600 Hz	
I DP10-17	POWER GROUND	GROUND	GROUND
I DP10-18	PASSENGER SWITCH PACK RH WINDOW UP REQUEST	B+ (MOMENTARY)	GROUND

### SECURITY AND LOCKING CONTROL MODULE

Pin	Description	Active	Inactive
S BT40-8	SCP NETWORK	2 – 1600 Hz	
S BT40-16	SCP NETWORK	2 – 1600 Hz	

NOTE: Refer to the Appendix at the rear of this book for CAN and SCP Network Messages.

Fig. 15.1

### COMPONENTS

Component	Connector / Type / Color	Location / Access
BODY PROCESSOR MODULE	FC14 / 104-WAY AMP EEEC / GREY	PASSENGER SIDE FASCIA / AIRBAG BRACKET
DOOR CONTROL MODULE – DRIVER	DD10 / 22-WAY FORD 2.8 TIMER / BLUE DD11 / 22-WAY FORD 2.8 TIMER / BLACK	DRIVER DOOR / DOOR CASING
DOOR CONTROL MODULE – PASSENGER	DP10 / 22-WAY FORD 2.8 TIMER / BLUE DP11 / 22-WAY FORD 2.8 TIMER / BLACK	PASSENGER DOOR / DOOR CASING
DOOR LOCK SWITCHES – DRIVER	DD3 / 13-WAY ECONOSEAL III LC / BLACK	DRIVER DOOR / DOOR CASING
MAJOR INSTRUMENT PACK	FC25 / 26-WAY AMP MICRO QUAD LOCK / BLACK FC26 / 26-WAY AMP MICRO QUAD LOCK / YELLOW	FASCIA
SECURITY AND LOCKING CONTROL MODULE	BT40 / 16-WAY FORD 2.8 TIMER / BLACK BT41 / 26-WAY FORD IDC / BLACK BT42 / 10-WAY FORD 2.8 TIMER / BLACK RH20 / COAXIAL CONNECTOR	TRUNK / ELECTRICAL CARRIER
WINDOW LIFT SWITCHES – DRIVER DOOR	DD17 / 20-WAY MULTILOCK 040 / BLACK	DRIVER DOOR SWITCH PACK
WINDOW LIFT SWITCHES – PASSENGER DOOR (PASSENGER DOOR SWITCH PACK)	DP17 / 20-WAY MULTILOCK 040 / BLACK	PASSENGER DOOR SWITCH PACK
WINDOW LIFT – DRIVER	DD16 / 6-WAY ECONOSEAL III LC / BLACK	DRIVER DOOR
WINDOW LIFT – PASSENGER	DP16 / 6-WAY ECONOSEAL III LC / BLACK	DRIVER DOOR

### HARNESS-TO-HARNESS CONNECTORS

Connector	Type / Color	Location / Access
AC14	14-WAY MULTILOCK 070 / GREY	FASCIA BOTTOM CONNECTOR MOUNTING BRACKET / RIGHT HAND SIDE
AC15	20-WAY MULTILOCK 070 / GREY	FASCIA BOTTOM CONNECTOR MOUNTING BRACKET / RIGHT HAND SIDE
AC16	6-WAY MULTILOCK 070 / YELLOW	LEFT HAND 'A' POST CONNECTOR MOUNTING BRACKET / 'A' POST TRIM
BT1	20-WAY MULTILOCK 070 / WHITE	TRUNK / ABOVE RIGHT HAND REAR WHEEL ARCH
BT2	20-WAY MULTILOCK 070 / WHITE	TRUNK / ABOVE RIGHT HAND REAR WHEEL ARCH
DD1	23-WAY AMP – FORD / BLACK	DRIVER SIDE 'A' POST MOUNTING BRACKET / 'A' POST TRIM
DP1	23-WAY AMP – FORD / BLACK	PASSENGER SIDE 'A' POST / 'A' POST TRIM
FC62	10-WAY AMP MQL / BLACK	CONVERTIBLE TOP SWITCH
RF1	24-WAY CONNECTOR / BLACK	RIGHT HAND 'A' POST CONNECTOR MOUNTING BRACKET / 'A' POST TRIM
RH12	18-WAY MULTILOCK 070 / YELLOW	REAR OF CENTER CONSOLE ASSEMBLY
RH2	20-WAY MULTILOCK 070 / WHITE	REAR OF CENTER CONSOLE ASSEMBLY

### GROUNDINGS

Ground	Location / Type
FC2AR	EYELET (PAIR) – RIGHT HAND LEG / RIGHT HAND 'A' POST
FC4AR	EYELET (PAIR) – RIGHT HAND LEG / LEFT HAND 'A' POST

FOR CONTROL MODULE PIN OUT INFORMATION, UNFOLD PAGE TO LEFT.

The following abbreviations are used to represent values for Control Module Pin-Out data

I	Input	SG	Sensor Ground	S	SCP Network	V	Voltage (DC)
O	Output	A	ACP Network	D	Serial and Encoded Data	Hz	Frequency
SS	Sensor Supply V	C	CAN (Network)	B+	Battery Voltage	kHz	Frequency x 1000

CAUTION: The information on this data page is furnished to aid the user in understanding circuit operation. THIS INFORMATION SHOULD BE USED FOR REFERENCE ONLY.

NOTE: The values listed are approximately those that can be expected at the control module connector pins with all circuit connections made and all components connected and fitted. "Active" means a load is applied or a switch is ON; "Inactive" means a load is not applied or a switch is OFF.

Refer to the front of this book for detailed information and illustrations regarding the location and identification of harnesses, relays, grounds, control modules and control module pins.



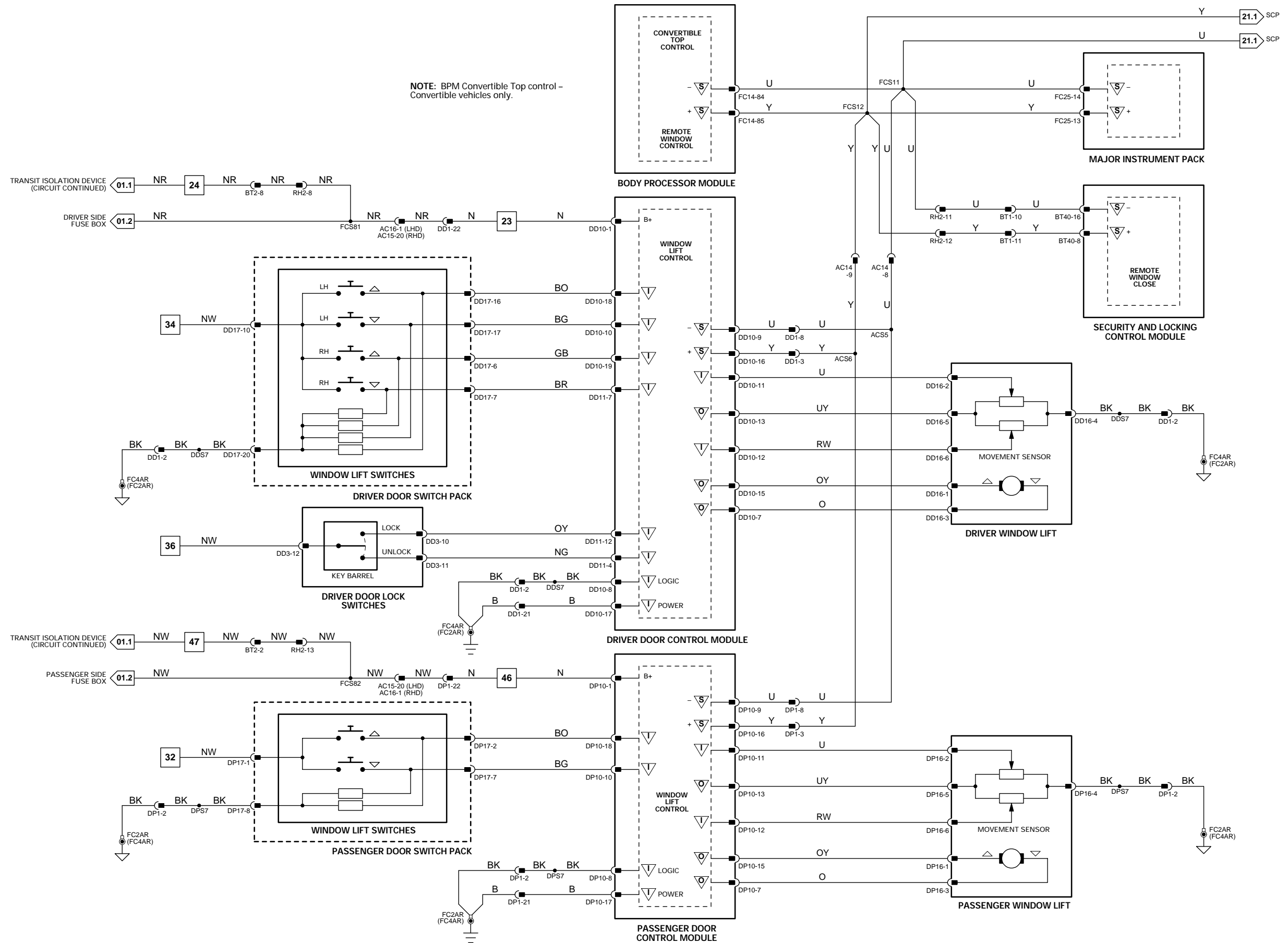

## CONTROL MODULE PIN OUT INFORMATION

### BODY PROCESSOR MODULE

Pin	Description	Active	Inactive
I FC14-10	CONVERTIBLE TOP RAISE REQUEST	GROUND (MOMENTARY)	B+
I FC14-15	IGNITION SWITCHED GROUND SUPPLY	GROUND	GROUND
I FC14-32	IGNITION SWITCHED GROUND SUPPLY	GROUND	GROUND
I FC14-33	IGNITION SWITCHED GROUND SUPPLY	GROUND	B+
I FC14-36	CONVERTIBLE TOP READY TO LATCH	GROUND	B+
I FC14-62	CONVERTIBLE TOP LATCH CLOSED	GROUND (CLOSED)	B+
I FC14-63	CONVERTIBLE TOP LOWER REQUEST	GROUND (MOMENTARY)	B+
O FC14-77	REAR QUARTER GLASS DOWN RELAYS ACTIVATE	GROUND	B+
I FC14-80	BATTERY POWER SUPPLY (LOGIC)	B+	B+
S FC14-84	SCP NETWORK	2 – 1600 Hz	B+
S FC14-85	SCP NETWORK	2 – 1600 Hz	B+
I FC14-89	CONVERTIBLE TOP CLOSED	GROUND	B+
O FC14-98	REAR QUARTER GLASS UP RELAYS ACTIVATE	GROUND	B+

### DRIVER DOOR CONTROL MODULE

Pin	Description	Active	Inactive
S DD10-9	SCP NETWORK	2 – 1600 Hz	
S DD10-16	SCP NETWORK	2 – 1600 Hz	

### MAJOR INSTRUMENT PACK

Pin	Description	Active	Inactive
S FC25-13	SCP NETWORK	2 – 1600 Hz	
S FC25-14	SCP NETWORK	2 – 1600 Hz	

### PASSENGER DOOR CONTROL MODULE

Pin	Description	Active	Inactive
S DP10-9	SCP NETWORK	2 – 1600 Hz	
S DP10-16	SCP NETWORK	2 – 1600 Hz	
C FC25-24	CAN NETWORK	15 – 1500 Hz	
C FC25-47	CAN NETWORK	15 – 1500 Hz	

### SECURITY AND LOCKING CONTROL MODULE

Pin	Description	Active	Inactive
O BT40-3	TOP UP RELAY ACTIVATE	B+	GROUND
O BT40-4	LATCH CONTROL VALVE	B+	GROUND
I BT40-6	BATTERY POWER SUPPLY	B+	B+
S BT40-8	SCP NETWORK	2 – 1600 Hz	
O BT40-9	MAIN CONTROL VALVE	B+	GROUND
O BT40-10	TOP DOWN RELAY ACTIVATE	B+	GROUND
I BT40-13	GROUND	GROUND	GROUND
I BT40-14	GROUND	GROUND	GROUND
S BT40-16	SCP NETWORK	2 – 1600 Hz	
I BT41-3	CONVERTIBLE TOP DOWN SWITCH	GROUND	B+

**NOTE:** Refer to the Appendix at the rear of this book for CAN and SCP Network Messages.

The following abbreviations are used to represent values for Control Module Pin-Out data

I	Input	SG	Sensor Ground	S	SCP Network	V	Voltage (DC)
O	Output	A	ACP Network	D	Serial and Encoded Data	Hz	Frequency
SS	Sensor Supply V	C	CAN (Network)	B+	Battery Voltage	kHz	Frequency x 1000

**CAUTION:** The information on this data page is furnished to aid the user in understanding circuit operation. THIS INFORMATION SHOULD BE USED FOR REFERENCE ONLY.

**NOTE:** The values listed are approximately those that can be expected at the control module connector pins with all circuit connections made and all components connected and fitted. “Active” means a load is applied or a switch is ON; “Inactive” means a load is not applied or a switch is OFF.

**Fig. 15.2**

### COMPONENTS

Component	Connector / Type / Color	Location / Access
BODY PROCESSOR MODULE	FC14 / 104-WAY AMP EEEC / GREY	PASSENGER SIDE FASCIA / AIRBAG BRACKET
CONVERTIBLE TOP CLOSED SWITCH	RF4 / 6-WAY MULTILOCK 070 / WHITE	TOP OF WINDSHIELD
CONVERTIBLE TOP DOWN SWITCH	RH29 / 3-WAY MULTILOCK 070 / WHITE	RIGHT HAND OPERATING CYLINDER
CONVERTIBLE TOP LATCH CLOSED SWITCH	RF4 / 6-WAY MULTILOCK 070 / WHITE	TOP OF WINDSHIELD
CONVERTIBLE TOP PUMP	BT15 / 2-WAY AMP / NATURAL	TRUNK / RIGHT HAND SIDE
CONVERTIBLE TOP RAISED SWITCH	RH29 / 3-WAY MULTILOCK 070 / WHITE	RIGHT HAND OPERATING CYLINDER
CONVERTIBLE TOP READY-TO-LATCH SWITCH	RF4 / 6-WAY MULTILOCK 070 / WHITE	TOP OF WINDSHIELD
CONVERTIBLE TOP SWITCH	FC62 / 10-WAY AMP MQL / BLACK	FORWARD OF GEAR SELECTOR
DOOR CONTROL MODULE – DRIVER	DD10 / 22-WAY FORD 2.8 TIMER / BLUE DD11 / 22-WAY FORD 2.8 TIMER / BLACK	DRIVER DOOR / DOOR CASING
DOOR CONTROL MODULE – PASSENGER	DP10 / 22-WAY FORD 2.8 TIMER / BLUE DP11 / 22-WAY FORD 2.8 TIMER / BLACK	PASSENGER DOOR / DOOR CASING
LATCH CONTROL VALVE	PH2 / 2-WAY DAUT & RIETZ / BLUE	TRUNK / CONVERTIBLE TOP PUMP
MAIN CONTROL VALVE	PH3 / 2-WAY DAUT & RIETZ / ORANGE	TRUNK / CONVERTIBLE TOP PUMP
MAJOR INSTRUMENT PACK	FC25 / 26-WAY AMP MICRO QUAD LOCK / BLACK FC26 / 26-WAY AMP MICRO QUAD LOCK / YELLOW	FASCIA
QUARTER LIGHT LIFT – LH	RH33 / 2-WAY ECONOSEAL III HC / BLACK	REAR QUARTER PANEL
QUARTER LIGHT LIFT – RH	RH34 / 2-WAY ECONOSEAL III HC / BLACK	REAR QUARTER PANEL
SECURITY AND LOCKING CONTROL MODULE	BT40 / 16-WAY FORD 2.8 TIMER / BLACK BT41 / 26-WAY FORD IDC / BLACK BT42 / 10-WAY FORD 2.8 TIMER / BLACK	TRUNK / ELECTRICAL CARRIER
	RH20 / COAXIAL CONNECTOR	

### RELAYS

Relay	Color / Stripe	Connector / Color	Location / Access
QUARTER DOWN RELAY – LH	BLACK	BT74 / BLACK	TRUNK RELAYS
QUARTER DOWN RELAY – RH	BLACK	BT76 / BLACK	TRUNK RELAYS
QUARTER UP RELAY – LH	BLACK	BT74 / BLACK	TRUNK RELAYS
QUARTER UP RELAY – RH	BLACK	BT76 / BLACK	TRUNK RELAYS
TOP UP RELAY	BLACK	BT16 / BLACK	TRUNK RELAYS
TOP DOWN RELAY	BLACK	BT17 / BLACK	TRUNK RELAYS

### HARNESS-TO-HARNESS CONNECTORS

Connector	Type / Color	Location / Access
AC14	14-WAY MULTILOCK 070 / GREY	FASCIA BOTTOM CONNECTOR MOUNTING BRACKET / RIGHT HAND SIDE
BT1	20-WAY MULTILOCK 070 / WHITE	TRUNK / ABOVE RIGHT HAND REAR WHEEL ARCH
BT3	18-WAY MULTILOCK 070 / YELLOW	TRUNK / ABOVE RIGHT HAND REAR WHEEL ARCH
DD1	23-WAY AMP – FORD / BLACK	DRIVER SIDE ‘A’ POST MOUNTING BRACKET/ ‘A’ POST TRIM
DP1	23-WAY AMP – FORD / BLACK	PASSENGER SIDE ‘A’ POST / ‘A’ POST TRIM
PH1	3-WAY MULTILOCK 070 / YELLOW	TRUNK
RF1	24-WAY CONNECTOR / BLACK	RIGHT HAND ‘A’ POST CONNECTOR MOUNTING BRACKET / ‘A’ POST TRIM
RF5	8-WAY MULTILOCK 070 / WHITE	LOWER RH ‘A’ POST / ‘A’ POST TRIM
RH2	20-WAY MULTILOCK 070 / WHITE	REAR OF CENTER CONSOLE ASSEMBLY
RH5	3-WAY MULTILOCK 070 / WHITE	BEHIND LEFT HAND QUARTER TRIM PANEL
RH6	3-WAY MULTILOCK 070 / WHITE	BEHIND RIGHT HAND QUARTER TRIM PANEL
RH12	18-WAY MULTILOCK 070 / YELLOW	REAR OF CENTER CONSOLE ASSEMBLY

### GROUNDS

Ground	Location / Type
BT1AL	EYELET (PAIR) – LEFT HAND LEG / ADJACENT TO BATTERY
BT1AR	EYELET (PAIR) – RIGHT HAND LEG / ADJACENT TO BATTERY
BT1BL	EYELET (PAIR) – LEFT HAND LEG / ADJACENT TO BATTERY
BT1BR	EYELET (PAIR) – RIGHT HAND LEG / ADJACENT TO BATTERY
BT2BL	EYELET (PAIR) – LEFT HAND LEG / TRUNK, RIGHT REAR
FC3BR	EYELET (PAIR) – RIGHT HAND LEG / TRANSMISSION TUNNEL, LEFT HAND SIDE
RH1S	EYELET (SINGLE) / RIGHT HAND REAR QUARTER

FOR CONTROL MODULE PIN OUT INFORMATION, UNFOLD PAGE TO LEFT.

Refer to the front of this book for detailed information and illustrations regarding the location and identification of harnesses, relays, grounds, control modules and control module pins.

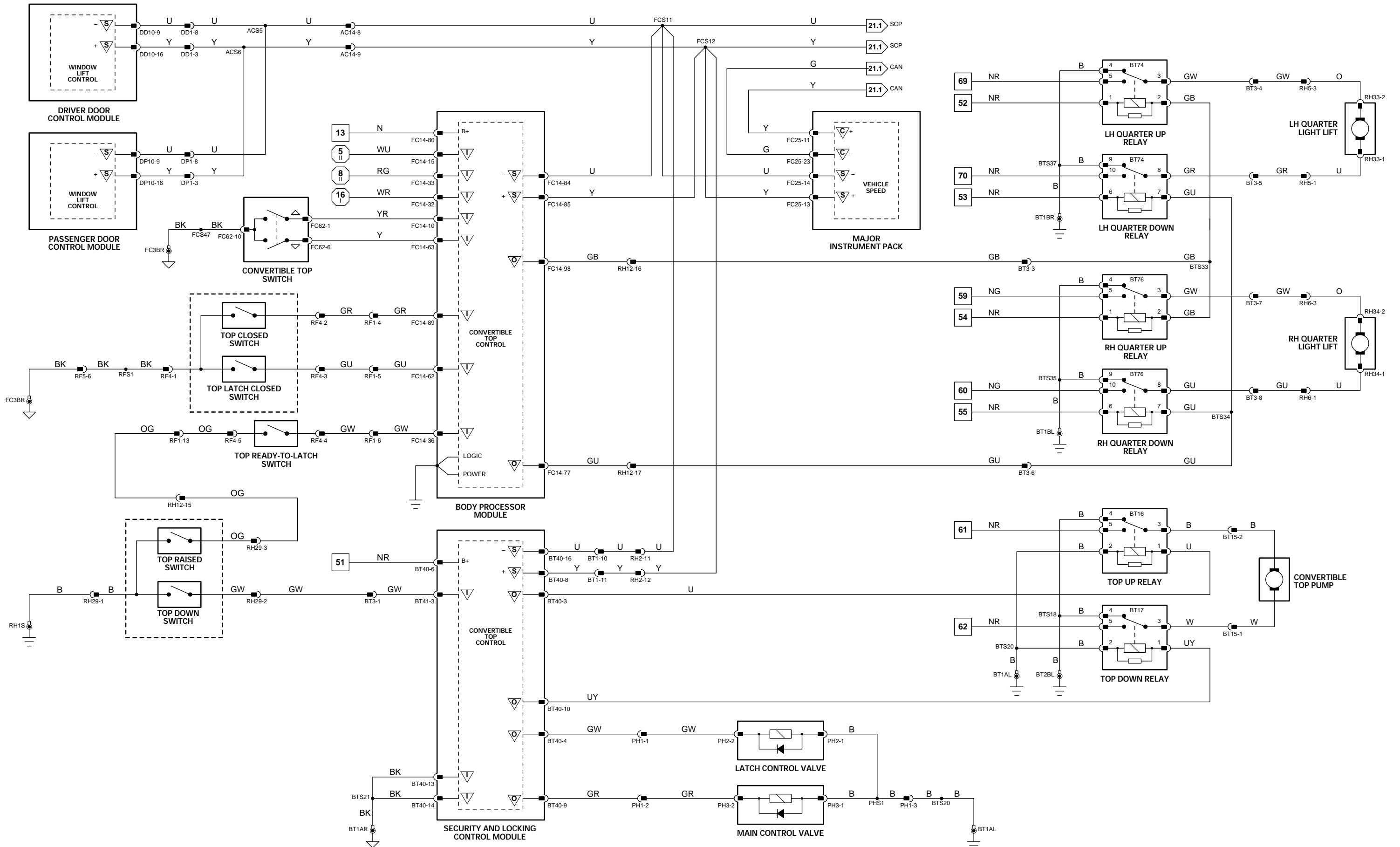

1 → 7 Fig. 01.1    1 → 5 Fig. 01.1    8 → 50 Fig. 01.2    51 → 90 Fig. 01.3    6 → 58 Fig. 01.4    59 → 73 Fig. 01.5    1 → 18 Fig. 02.1

Input   
 Sensor Supply V   
 ACP   
 SCP  
 Output   
 Sensor Ground   
 CAN   
 Serial and Encoded Data

**VARIANT:** Convertible Vehicles  
**VIN RANGE:** A11051 →  
**DATE OF ISSUE:** September 2000

CONTROL MODULE PIN OUT INFORMATION

MAJOR INSTRUMENT PACK

Pin	Description	Active	Inactive
C	FC25-11	CAN NETWORK	15 – 1500 Hz
C	FC25-23	CAN NETWORK	15 – 1500 Hz
O	FC26-20	VEHICLE SPEED	22 Hz @ 10 MPH (16 KM/H); 44 Hz @ 20 MPH (32 KM/H) @ B+

NOTE: Refer to the Appendix at the rear of this book for CAN and SCP Network Messages.

Fig. 16.1

COMPONENTS

Component	Connector / Type / Color	Location / Access
ANTENNA MOTOR	BT19 / 6-WAY YAZAKI C.S.U. / WHITE	TRUNK / RIGHT HAND SIDE
CD AUTO-CHANGER	IC7 / 8-WAY ALPINE	TRUNK / RIGHT HAND SIDE
MAJOR INSTRUMENT PACK	FC25 / 26-WAY AMP MICRO QUAD LOCK / BLACK FC26 / 26-WAY AMP MICRO QUAD LOCK / YELLOW	FASCIA
RADIO / CASSETTE HEAD UNIT	IC8 / 8-WAY ALPINE / BLACK IC19 / 12-WAY MULTILOCK 070 / WHITE IC20 / 26-WAY MQS / YELLOW	CENTER CONSOLE
RADIO ANTENNA	IC12 / COAXIAL CONNECTOR	TRUNK / RIGHT HAND SIDE
RADIO CONTROL SWITCHES (STEERING WHEEL)	SW4 / 3-WAY EPC / BLACK	STEERING WHEEL
SPEAKER – DRIVER DOOR (MID-BASS)	DD19 / 2-WAY GROTE AND HARTMAN MDK / BLACK	DRIVER DOOR CASING
SPEAKER – PASSENGER DOOR (MID-BASS)	DP19 / 2-WAY GROTE AND HARTMAN MDK / BLACK	PASSENGER DOOR CASING
SPEAKER – LH SIDE FASCIA	FC38 / 2-WAY MULTILOCK 070 / GREY	FASCIA / LH SIDE
SPEAKER – RH SIDE FASCIA	FC39 / 2-WAY MULTILOCK 070 / GREY	FASCIA / RH SIDE
SPEAKER – LH SIDE REAR (CONVERTIBLE)	RH26 / 2-WAY GROTE AND HARTMAN MDK / BLACK	INTERIOR REAR QUARTER PANEL
SPEAKER – RH SIDE REAR (CONVERTIBLE)	RH27 / 2-WAY GROTE AND HARTMAN MDK / BLACK	INTERIOR REAR QUARTER PANEL
SPEAKER – LH SIDE REAR QUARTER (COUPE)	RH30 / 2-WAY GROTE AND HARTMAN MDK / BLACK	INTERIOR REAR QUARTER PANEL
SPEAKER – RH SIDE REAR QUARTER (COUPE)	RH31 / 2-WAY GROTE AND HARTMAN MDK / BLACK	INTERIOR REAR QUARTER PANEL

HARNESSTO-HARNESSTO CONNECTORS

Connector	Type / Color	Location / Access
AC14	14-WAY MULTILOCK 070 / GREY	FASCIA BOTTOM CONNECTOR MOUNTING BRACKET / RIGHT HAND SIDE
BT1	20-WAY MULTILOCK 070 / WHITE	TRUNK / ABOVE RIGHT HAND REAR WHEEL ARCH
DD1	23-WAY AMP – FORD / BLACK	DRIVER SIDE 'A' POST MOUNTING BRACKET/ 'A' POST TRIM
DP1	23-WAY AMP – FORD / BLACK	PASSENGER SIDE 'A' POST / 'A' POST TRIM
IC1	20-WAY MULTILOCK 070 / YELLOW	BELOW CENTER CONSOLE GLOVE BOX
IC2	14-WAY MULTILOCK 070 / WHITE	BELOW CENTER CONSOLE GLOVE BOX
RH1	20-WAY MULTILOCK 070 / GREY	BEHIND GLOVE BOX
SC2	10-WAY MULTILOCK 070 / YELLOW	ADJACENT TO STEERING COLUMN MOTOR
SC3	12-WAY MULTILOCK 070 / GREY	RIGHT HAND SIDE OF STEERING COLUMN
SW1	12-WAY MULTILOCK 040 / BLACK	INSIDE STEERING COLUMN COWL
SW2	6-WAY JST / WHITE	CENTER OF STEERING WHEEL

GROUND

Ground	Location / Type
BT1AL	EYELET (PAIR) – LEFT HAND LEG / ADJACENT TO BATTERY
CE2	EYELET (SINGLE) / ABOVE RIGHT HAND SIDE OF TRANSMISSION TUNNEL
FC3BL	EYELET (PAIR) – LEFT HAND LEG / TRANSMISSION TUNNEL, LEFT HAND SIDE

FOR CONTROL MODULE PIN OUT INFORMATION, UNFOLD PAGE TO LEFT.

The following abbreviations are used to represent values for Control Module Pin-Out data

I	Input	SG	Sensor Ground	S	SCP Network	V	Voltage (DC)
O	Output	A	ACP Network	D	Serial and Encoded Data	Hz	Frequency
SS	Sensor Supply V	C	CAN (Network)	B+	Battery Voltage	kHz	Frequency x 1000

CAUTION: The information on this data page is furnished to aid the user in understanding circuit operation. THIS INFORMATION SHOULD BE USED FOR REFERENCE ONLY.

NOTE: The values listed are approximately those that can be expected at the control module connector pins with all circuit connections made and all components connected and fitted. "Active" means a load is applied or a switch is ON; "Inactive" means a load is not applied or a switch is OFF.

Refer to the front of this book for detailed information and illustrations regarding the location and identification of harnesses, relays, grounds, control modules and control module pins.

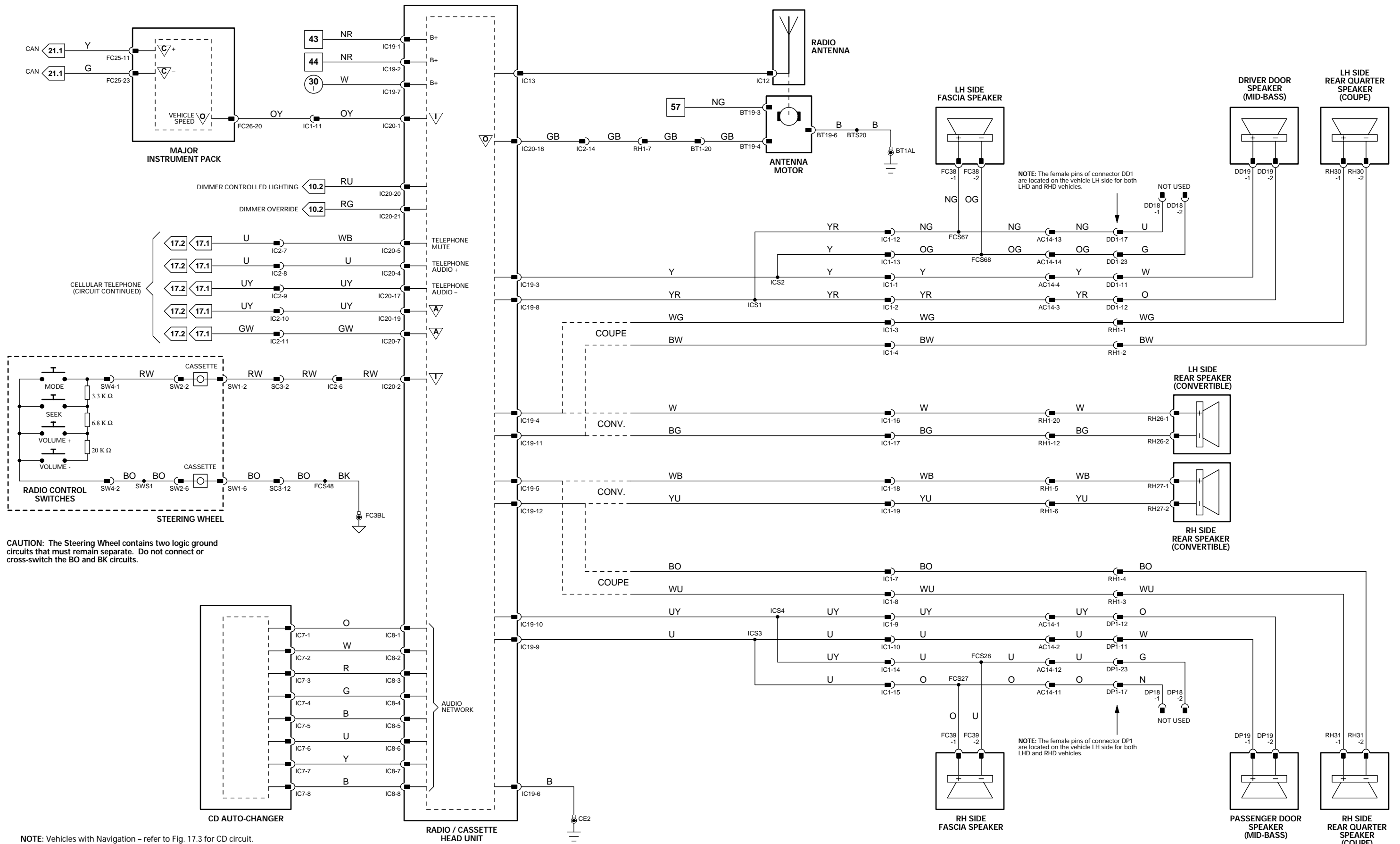

CAUTION: The Steering Wheel contains two logic ground circuits that must remain separate. Do not connect or cross-switch the BO and BK circuits.

NOTE: Vehicles with Navigation – refer to Fig. 17.3 for CD circuit.

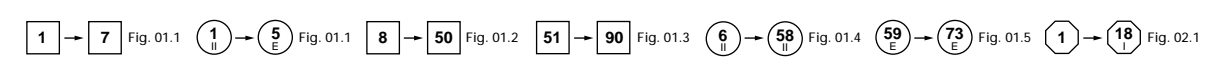

VARIANT: Standard ICE Vehicles  
 VIN RANGE: A11051 →  
 DATE OF ISSUE: September 2000

CONTROL MODULE PIN OUT INFORMATION

MAJOR INSTRUMENT PACK

Pin	Description	Active	Inactive
C	FC25-11 CAN NETWORK	15 – 1500 Hz	
C	FC25-11 CAN NETWORK	15 – 1500 Hz	
O	FC25-11 VEHICLE SPEED	22 Hz @ 10 MPH (16 KM/H); 44 Hz @ 20 MPH (32 KM/H) @ B+	

NOTE: Refer to the Appendix at the rear of this book for CAN and SCP Network Messages.

Fig. 16.2

COMPONENTS

Component	Connector / Type / Color	Location / Access
ANTENNA MOTOR	BT19 / 6-WAY YAZAKI C.S.U. / WHITE	TRUNK / RIGHT HAND SIDE
CD AUTO-CHANGER	IC7 / 8-WAY ALPINE	TRUNK / RIGHT HAND SIDE
MAJOR INSTRUMENT PACK	FC25 / 26-WAY AMP MICRO QUAD LOCK / BLACK FC26 / 26-WAY AMP MICRO QUAD LOCK / YELLOW	FASCIA
POWER AMPLIFIER	IC7 / 8-WAY ALPINE / BLACK IC15 / 18-WAY / MULTILOCK 070 / WHITE IC16 / 12-WAY MULTILOCK 070 / WHITE	TRUNK / RIGHT HAND SIDE
RADIO / CASSETTE HEAD UNIT	IC8 / 8-WAY ALPINE / BLACK IC19 / 12-WAY MULTILOCK 070 / WHITE IC20 / 26-WAY MQS / YELLOW	CENTER CONSOLE
RADIO ANTENNA	IC12 / COAXIAL CONNECTOR	TRUNK / RIGHT HAND SIDE
RADIO CONTROL SWITCHES (STEERING WHEEL)	SW4 / 3-WAY EPC / BLACK	STEERING WHEEL
SPEAKER – DRIVER DOOR (MID-BASS)	DD19 / 2-WAY GROTE AND HARTMAN MDK / BLACK	DRIVER DOOR CASING
SPEAKER – PASSENGER DOOR (MID-BASS)	DP19 / 2-WAY GROTE AND HARTMAN MDK / BLACK	PASSENGER DOOR CASING
SPEAKER – DRIVER DOOR (TWEETER)	DD18 / 2-WAY MULTILOCK 040 / BLACK	DRIVER DOOR
SPEAKER – PASSENGER DOOR (TWEETER)	DP18 / 2-WAY MULTILOCK 040 / BLACK	PASSENGER DOOR
SPEAKER – LH SIDE FASCIA	FC38 / 2-WAY MULTILOCK 070 / GREY	FASCIA / LH SIDE
SPEAKER – RH SIDE FASCIA	FC39 / 2-WAY MULTILOCK 070 / GREY	FASCIA / RH SIDE
SPEAKER – LH SIDE REAR (CONVERTIBLE)	RH26 / 2-WAY GROTE AND HARTMAN MDK / BLACK	INTERIOR REAR QUARTER PANEL
SPEAKER – RH SIDE REAR (CONVERTIBLE)	RH27 / 2-WAY GROTE AND HARTMAN MDK / BLACK	INTERIOR REAR QUARTER PANEL
SPEAKER – LH SIDE REAR QUARTER (COUPE)	RH30 / 2-WAY GROTE AND HARTMAN MDK / BLACK	INTERIOR REAR QUARTER PANEL
SPEAKER – RH SIDE REAR QUARTER (COUPE)	RH31 / 2-WAY GROTE AND HARTMAN MDK / BLACK	INTERIOR REAR QUARTER PANEL
SPEAKER – REAR (COUPE)	RH26 / 2-WAY GROTE AND HARTMAN MDK / BLACK RH27 / 2-WAY GROTE AND HARTMAN MDK / BLACK	PARCEL SHELF

HARNESS-TO-HARNESS CONNECTORS

Connector	Type / Color	Location / Access
AC14	14-WAY MULTILOCK 070 / GREY	FASCIA BOTTOM CONNECTOR MOUNTING BRACKET / RIGHT HAND SIDE
BT1	20-WAY MULTILOCK 070 / WHITE	TRUNK / ABOVE RIGHT HAND REAR WHEEL ARCH
DD1	23-WAY AMP – FORD / BLACK	DRIVER SIDE 'A' POST MOUNTING BRACKET / 'A' POST TRIM
DP1	23-WAY AMP – FORD / BLACK	PASSENGER SIDE 'A' POST / 'A' POST TRIM
IC1	20-WAY MULTILOCK 070 / YELLOW	BELOW CENTER CONSOLE GLOVE BOX
IC2	14-WAY MULTILOCK 070 / WHITE	BELOW CENTER CONSOLE GLOVE BOX
IC4	4-WAY MULTILOCK 070 / WHITE	TRUNK / LEFT OF ANTENNA ASSEMBLY
RH1	20-WAY MULTILOCK 070 / GREY	BEHIND GLOVE BOX
SC3	12-WAY MULTILOCK 070 / GREY	RIGHT HAND SIDE OF STEERING COLUMN
SW1	12-WAY MULTILOCK 040 / BLACK	INSIDE STEERING COLUMN COWL
SW2	6-WAY JST / WHITE	CENTER OF STEERING WHEEL

GROUND

Ground	Location / Type
BT1AL	EYELET (PAIR) – LEFT HAND LEG / ADJACENT TO BATTERY
BT1AR	EYELET (PAIR) – RIGHT HAND LEG / ADJACENT TO BATTERY
BT1CS	EYELET (SINGLE) / ADJACENT TO BATTERY
CE2	EYELET (SINGLE) / ABOVE RIGHT HAND SIDE OF TRANSMISSION TUNNEL
FC3BL	EYELET (PAIR) – LEFT HAND LEG / TRANSMISSION TUNNEL, LEFT HAND SIDE

FOR CONTROL MODULE PIN OUT INFORMATION, UNFOLD PAGE TO LEFT.

The following abbreviations are used to represent values for Control Module Pin-Out data

I	Input	SG	Sensor Ground	S	SCP Network	V	Voltage (DC)
O	Output	A	ACP Network	D	Serial and Encoded Data	Hz	Frequency
SS	Sensor Supply V	C	CAN (Network)	B+	Battery Voltage	kHz	Frequency x 1000

CAUTION: The information on this data page is furnished to aid the user in understanding circuit operation. THIS INFORMATION SHOULD BE USED FOR REFERENCE ONLY.

NOTE: The values listed are approximately those that can be expected at the control module connector pins with all circuit connections made and all components connected and fitted. "Active" means a load is applied or a switch is ON; "Inactive" means a load is not applied or a switch is OFF.

Refer to the front of this book for detailed information and illustrations regarding the location and identification of harnesses, relays, grounds, control modules and control module pins.

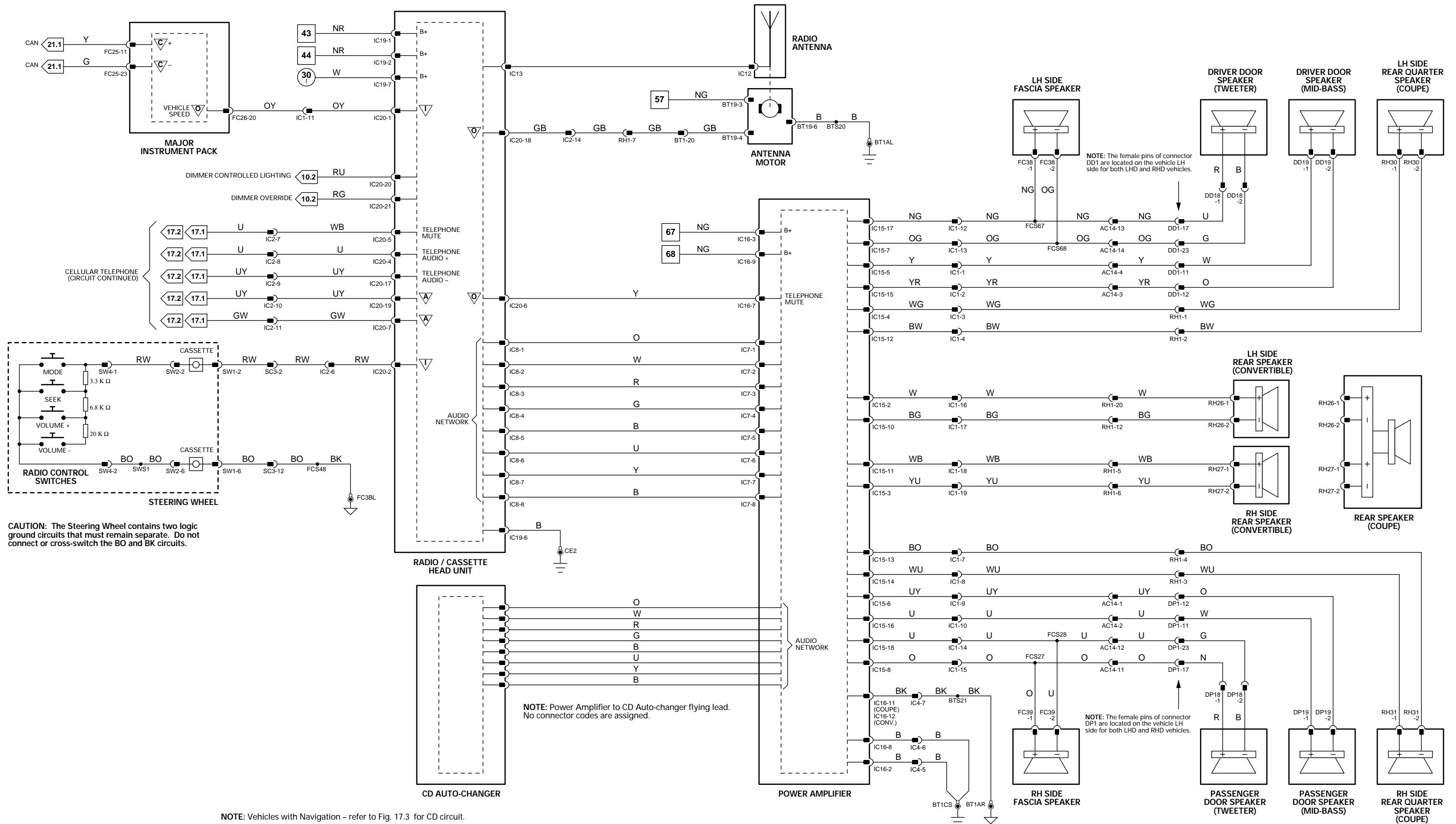

**Fig. 17.1****COMPONENTS****Component**

CELLULAR PHONE CONTROL MODULE (PORTABLE PHONE)  
 HANDSET  
 MICROPHONE  
 TELEPHONE ANTENNA

**Connector / Type / Color**

RT2 / 12-WAY MULTILOCK 42 / BLACK  
 RT5 / 16-WAY MULTILOCK 42 / BLACK  
 RT4 / TELEPHONE / PROPRIETARY  
 RF9 / 2-WAY MULTILOCK 040 / BLUE  
 RT7 / 2-WAY HIROSE COAX GT SERIES

**Location / Access**

BEHIND REAR SEAT  
 CENTER CONSOLE  
 ROOF CONSOLE  
 TRUNK / ABOVE LH WHEEL ARCH

**HARNESS-TO-HARNESS CONNECTORS****Connector**

IC2  
 RF1  
 RT1  
 RT3  
 RT6  
 RT8  
 RT11

**Type / Color**

14-WAY MULTILOCK 070 / WHITE  
 24-WAY CONNECTOR / BLACK  
 14-WAY MULTILOCK 070 / YELLOW  
 10-WAY CONNECTOR / GREY  
 2-WAY HIROSE COAX GT SERIES / GREY  
 2-WAY HIROSE COAX GT SERIES / GREY  
 10-WAY CONNECTOR / BLACK

**Location / Access**

BELOW CENTER CONSOLE GLOVE BOX  
 RIGHT HAND 'A' POST CONNECTOR MOUNTING BRACKET / 'A' POST TRIM  
 BELOW CENTER CONSOLE  
 BELOW CENTER CONSOLE  
 BELOW CENTER CONSOLE  
 BEHIND REAR SEAT  
 CENTER CONSOLE GLOVE BOX

**GROUND****Ground**

FC2CS  
 FC4CS

**Location / Type**

EYELET (SINGLE) / RIGHT HAND 'A' POST  
 EYELET (SINGLE) / LEFT HAND 'A' POST

Refer to the front of this book for detailed information and illustrations regarding the location and identification of harnesses, relays, grounds, control modules and control module pins.



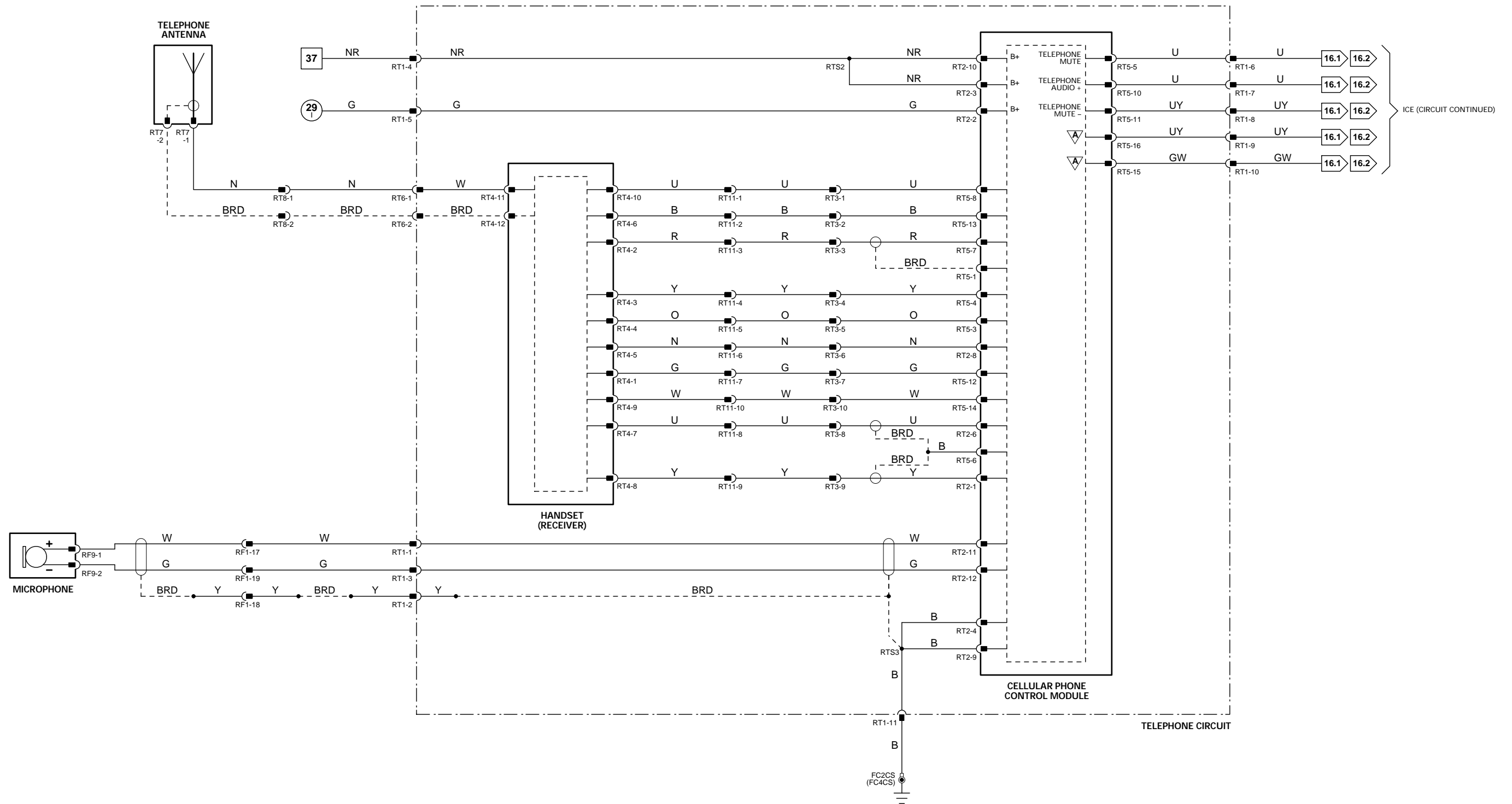

1 → 7 Fig. 01.1   
 1 → 5 Fig. 01.1   
 8 → 50 Fig. 01.2   
 51 → 90 Fig. 01.3   
 6 → 58 Fig. 01.4   
 59 → 73 Fig. 01.5   
 1 → 18 Fig. 02.1

▽ Input                      + Sensor Supply V                      ▽ ACP                      S SCP  
 ▽ Output                      - Sensor Ground                      ▽ CAN                      D Serial and Encoded Data

**VARIANT:** NAS Vehicles  
**VIN RANGE:** A11051 →  
**DATE OF ISSUE:** September 2000

**Fig. 17.2****COMPONENTS****Component**

CELLULAR PHONE CONTROL MODULE (FIXED PHONE)  
 HANDSET  
 MICROPHONE  
 TELEPHONE ANTENNA

**Connector / Type / Color**

RT9 / 32-WAY CONNECTOR / BLUE  
 RT11 / 10-WAY CONNECTOR / BLACK  
 RF9 / 2-WAY MULTILOCK 040 / BLUE  
 RT7 / COAXIAL

**Location / Access**

BEHIND REAR SEAT  
 CENTER CONSOLE GLOVE BOX  
 ROOF CONSOLE  
 TRUNK / RIGHT HAND SIDE

**HARNESS-TO-HARNESS CONNECTORS****Connector**

IC2  
 RF1  
 RT1  
 RT3  
 RT6  
 RT8

**Type / Color**

14-WAY MULTILOCK 070 / WHITE  
 24-WAY CONNECTOR / BLACK  
 14-WAY MULTILOCK 070 / YELLOW  
 10-WAY CONNECTOR / GREY  
 2-WAY HIROSE COAX GT SERIES / GREY  
 2-WAY HIROSE COAX GT SERIES / GREY

**Location / Access**

BELOW CENTER CONSOLE GLOVE BOX  
 RIGHT HAND 'A' POST CONNECTOR MOUNTING BRACKET / 'A' POST TRIM  
 BELOW CENTER CONSOLE  
 BELOW CENTER CONSOLE  
 BELOW CENTER CONSOLE  
 BEHIND REAR SEAT

**GROUNDS****Ground**

FC2CS  
 FC4CS

**Location / Type**

EYELET (SINGLE) / RIGHT HAND 'A' POST  
 EYELET (SINGLE) / LEFT HAND 'A' POST

Refer to the front of this book for detailed information and illustrations regarding the location and identification of harnesses, relays, grounds, control modules and control module pins.

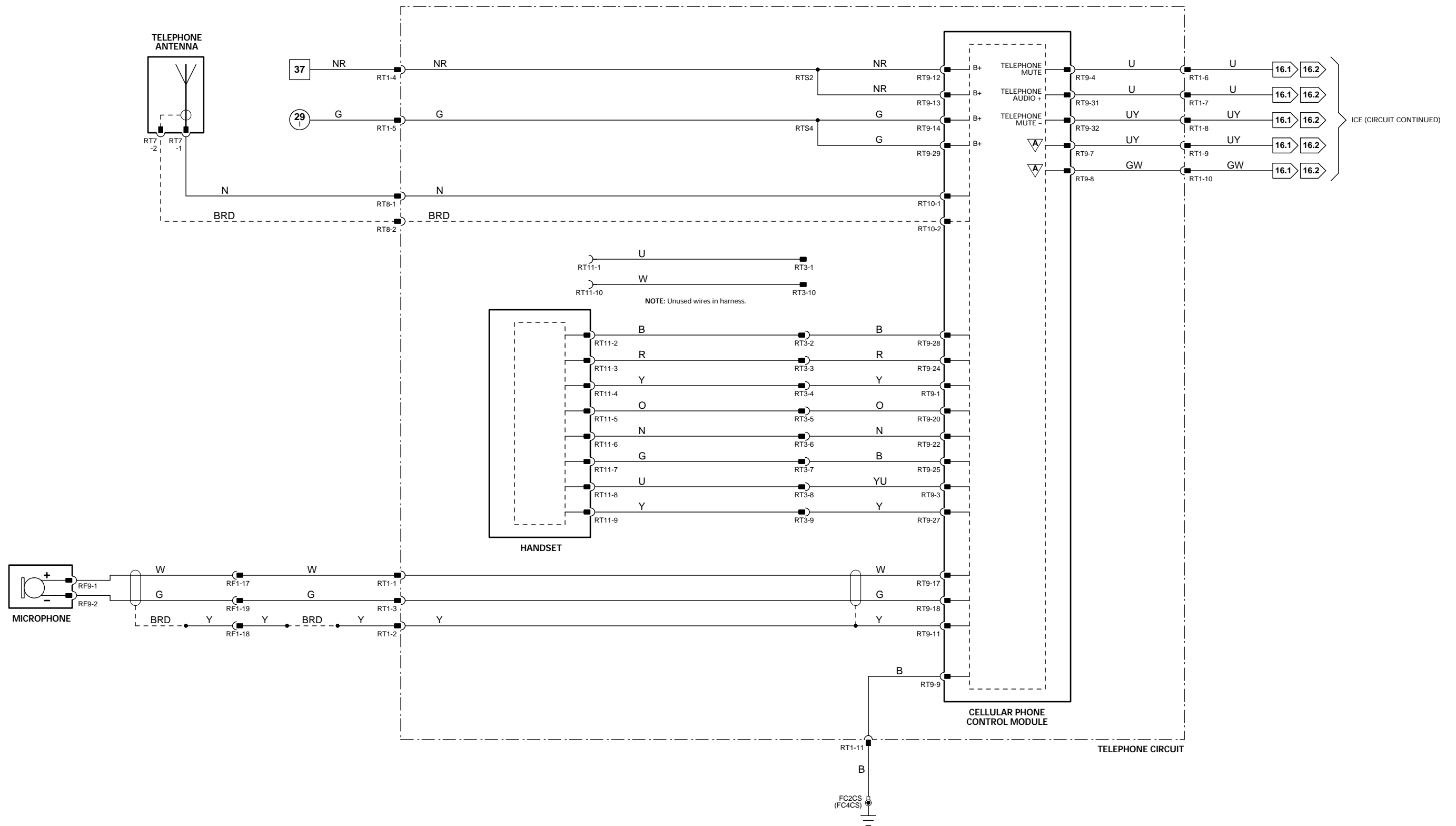

**Fig. 17.3**

**COMPONENTS**

Component	Connector / Type / Color	Location / Access
CD AUTO-CHANGER	IC7 / 8-WAY ALPINE	TRUNK / RIGHT HAND SIDE
NAVIGATION CONTROL MODULE	IC7 / 8-WAY ALPINE / BLACK IC22 / 16-WAY AMP ML42 / BLACK IC23 / 24-WAY AMP ML42 / BLACK	TRUNK / RIGHT HAND SIDE
NAVIGATION DISPLAY	FC97 / 12-WAY AMP ML42 / BLACK FC98 / 16-WAY AMP ML42 / BLACK	BEHIND NAVIGATION DISPLAY
NAVIGATION GPS ANTENNA	IC5 / 2-WAY HIROSE COAX GT5 SERIES / GREY	BELOW PARCEL SHELF
POWER AMPLIFIER	IC7 / 8-WAY ALPINE / BLACK IC15 / 18-WAY / MULTILOCK 070 / WHITE IC16 / 12-WAY MULTILOCK 070 / WHITE	TRUNK / RIGHT HAND SIDE
RADIO / CASSETTE HEAD UNIT	IC8 / 8-WAY ALPINE / BLACK IC19 / 12-WAY MULTILOCK 070 / WHITE IC20 / 26-WAY MQS / YELLOW	CENTER CONSOLE

**HARNESS-TO-HARNESS CONNECTORS**

Connector	Type / Color	Location / Access
IC1	20-WAY MULTILOCK 070 / YELLOW	BELOW CENTER CONSOLE GLOVE BOX
IC2	14-WAY MULTILOCK 070 / WHITE	BELOW CENTER CONSOLE GLOVE BOX
IC3	14-WAY MULTILOCK 070 / GREY	BELOW CENTER CONSOLE GLOVE BOX
IC4	4-WAY MULTILOCK 070 / WHITE	TRUNK / LEFT OF ANTENNA ASSEMBLY

**GROUND**

Ground	Location / Type
BT2AR	EYELET (PAIR) – RIGHT HAND LEG / TRUNK, RIGHT REAR
EM1AL	EYELET (PAIR) – LEFT HAND LEG / ENGINE COMPARTMENT, RIGHT HAND ENCLOSURE
EM2AL	EYELET (PAIR) – LEFT HAND LEG / ENGINE COMPARTMENT, LEFT HAND ENCLOSURE
FC3BL	EYELET (PAIR) – LEFT HAND LEG / TRANSMISSION TUNNEL, LEFT HAND SIDE

Refer to the front of this book for detailed information and illustrations regarding the location and identification of harnesses, relays, grounds, control modules and control module pins.

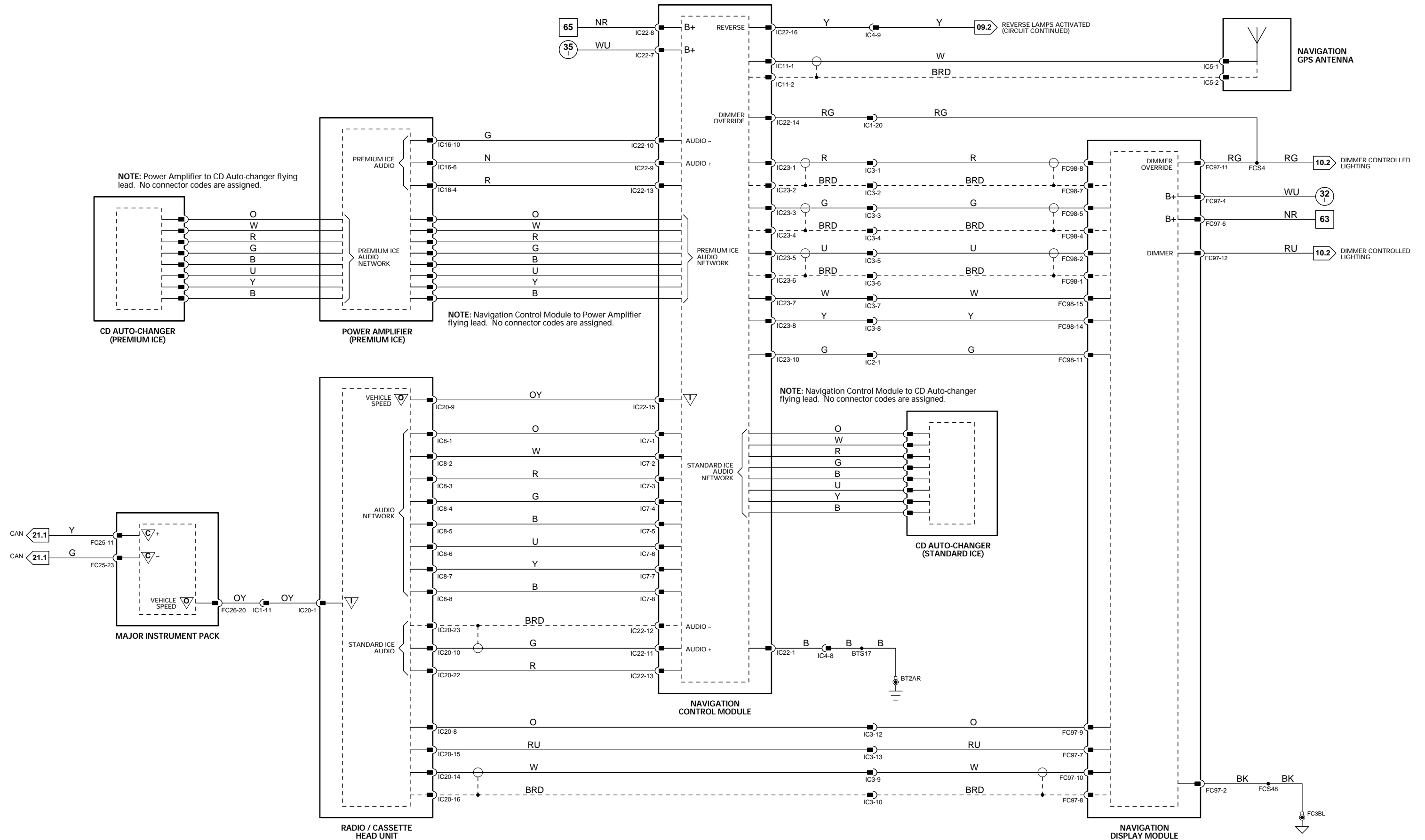

**Fig. 17.4**

**COMPONENTS**

**Component**

NAVIGATION CONTROL MODULE

NAVIGATION DISPLAY

NAVIGATION GPS ANTENNA  
PARKING BRAKE SWITCH  
POWER AMPLIFIER

RADIO / CASSETTE HEAD UNIT

TELEVISION ANTENNA – RH #1  
TELEVISION ANTENNA – RH #2  
TELEVISION ANTENNA – LH #3  
TELEVISION ANTENNA – LH #4  
TELEVISION ANTENNA AMPLIFIER

TELEVISION MODULE

VEHICLE INFORMATION CONTROL BEACON MODULE  
VEHICLE INFORMATION CONTROL INFRARED SENSOR  
VEHICLE INFORMATION CONTROL MODULE

**Connector / Type / Color**

IC7 / 8-WAY ALPINE / BLACK  
IC22 / 16-WAY AMP ML42 / BLACK  
IC23 / 24-WAY AMP ML42 / BLACK  
FC97 / 12-WAY AMP ML42 / BLACK  
FC98 / 16-WAY AMP ML42 / BLACK  
IC5 / 2-WAY HIROSE COAX GT5 SERIES / GREY  
FC19 / 1-WAY LUCAR POSILOCK / BLACK  
IC7 / 8-WAY ALPINE / BLACK  
IC15 / 18-WAY / MULTILOCK 070 / WHITE  
IC16 / 12-WAY MULTILOCK 070 / WHITE  
IC8 / 8-WAY ALPINE / BLACK  
IC19 / 12-WAY MULTILOCK 070 / WHITE  
IC20 / 26-WAY MQS / YELLOW  
TV4 / 1-WAY ANTENNA / BLACK  
TV34 / 1-WAY ANTENNA / METALLIC  
TV3 / 1-WAY ANTENNA / BLACK  
TV35 / 1-WAY ANTENNA / METALLIC  
TV15 / 3-WAY ANTENNAE INPUT / GREY  
TV18 / 3-WAY ANTENNAE INPUT / GREY  
TV5 / 2-WAY 3.5 MM JACK PLUG / BLACK  
TV6 / 2-WAY 3.5 MM JACK PLUG / BLACK  
TV7 / 2-WAY 3.5 MM JACK PLUG / BLACK  
TV8 / 8-WAY AMP ML42 MICROLOCK / BLACK  
TV10 / 8-WAY DIN / BLACK  
IR1 / 2-WAY HIROSE COAX GT5 SERIES / GREY  
TV12 / 4-WAY DIN / BLACK  
TV14 / 8-WAY DIN / BLACK

**Location / Access**

TRUNK / RIGHT HAND SIDE  
  
BEHIND NAVIGATION DISPLAY  
  
BELOW PARCEL SHELF  
BELOW PARKING BRAKE LEVER  
TRUNK / RIGHT HAND SIDE  
  
CENTER CONSOLE  
  
REAR WINDOW  
REAR WINDOW  
REAR WINDOW  
REAR WINDOW  
ABOVE LH REAR INNER WHEEL ARCH  
ABOVE LH REAR INNER WHEEL ARCH  
ON TRUNK FUSE BOX HOUSING  
  
SPARE WHEEL WELL  
BELOW CENTER CONSOLE GLOVE BOX  
SPARE WHEEL WELL  
SPARE WHEEL WELL

**HARNESSTO-HARNESSTO CONNECTORS**

**Connector**

IC1  
IC2  
IC3  
IC4

**Type / Color**

20-WAY MULTILOCK 070 / YELLOW  
14-WAY MULTILOCK 070 / WHITE  
14-WAY MULTILOCK 070 / GREY  
4-WAY MULTILOCK 070 / WHITE

**Location / Access**

BELOW CENTER CONSOLE GLOVE BOX  
BELOW CENTER CONSOLE GLOVE BOX  
BELOW CENTER CONSOLE GLOVE BOX  
TRUNK / LEFT OF ANTENNA ASSEMBLY

**GROUNDS**

**Ground**

BT2AR  
EM1AL  
EM2AL  
FC3BL  
TV36  
TV38

**Location / Type**

EYELET (PAIR) – RIGHT HAND LEG / TRUNK, RIGHT REAR  
EYELET (PAIR) – LEFT HAND LEG / ENGINE COMPARTMENT, RIGHT HAND ENCLOSURE  
EYELET (PAIR) – LEFT HAND LEG / ENGINE COMPARTMENT, LEFT HAND ENCLOSURE  
EYELET (PAIR) – LEFT HAND LEG / TRANSMISSION TUNNEL, LEFT HAND SIDE  
EYELET (SINGLE) / BELOW PARCEL SHELF  
EYELET (SINGLE) / ADJACENT TO BATTERY

Refer to the front of this book for detailed information and illustrations regarding the location and identification of harnesses, relays, grounds, control modules and control module pins.

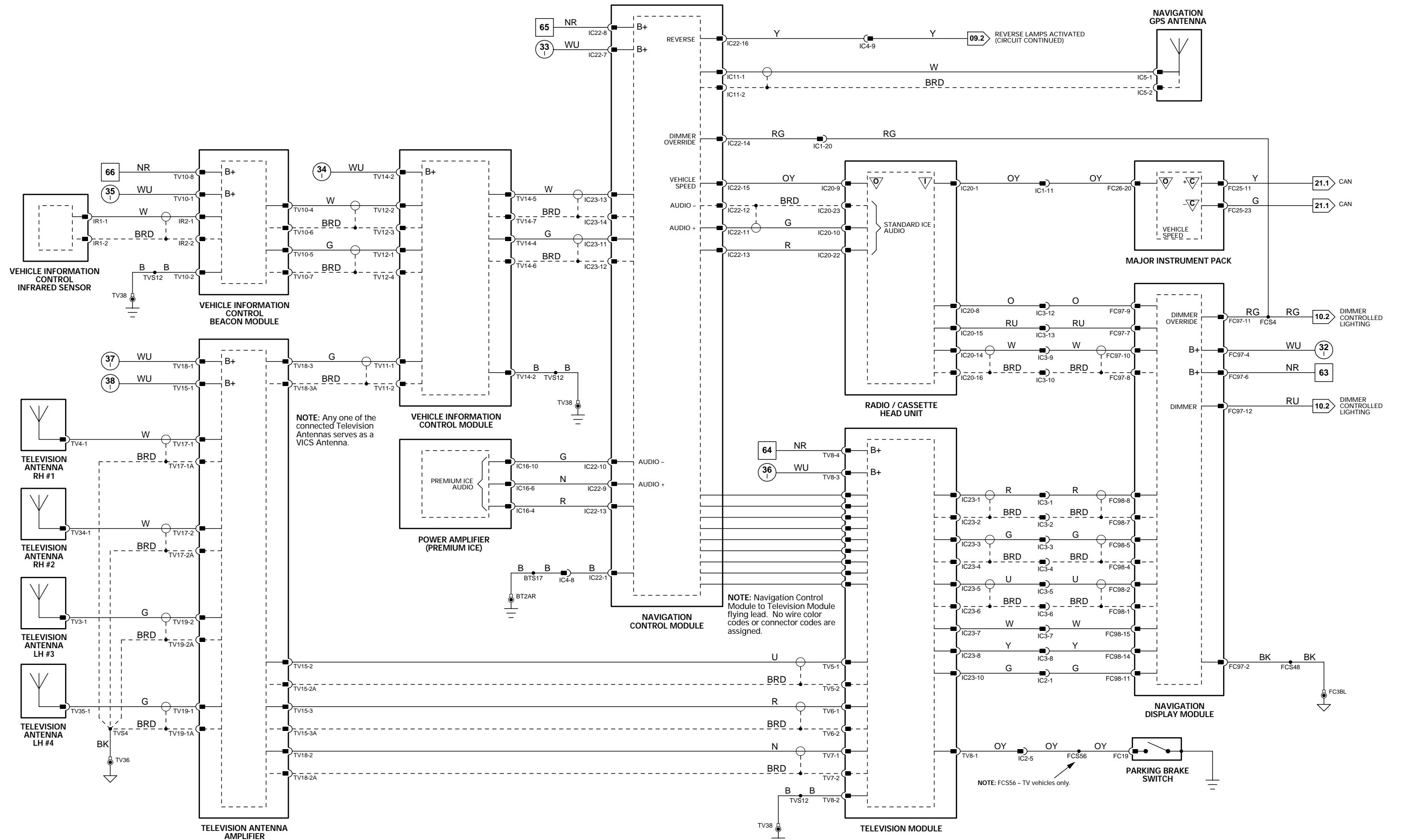

NOTE: Refer to Fig. 17.3 for Navigation vehicles CD Auto-changer circuits.

1 → 7 Fig. 01.1    1 → 5 Fig. 01.1    8 → 50 Fig. 01.2    51 → 90 Fig. 01.3    6 → 58 Fig. 01.4    59 → 73 Fig. 01.5    1 → 18 Fig. 02.1

	Input		Sensor Supply V		ACP		SCP
	Output		Sensor Ground		CAN		Serial and Encoded Data

**VARIANT:** TV and VICS Vehicles  
**VIN RANGE:** A11051 →  
**DATE OF ISSUE:** September 2000

**Fig. 18.1****COMPONENTS****Component**

CRASH SENSOR - FRONT  
 CRASH SENSOR - SIDE, LH  
 CRASH SENSOR - SIDE, RH  
 DRIVER SEAT BELT SWITCH  
 DRIVER SEAT TRACK SWITCH  
 IGNITOR - LH SEAT BELT PRETENSIONER  
 IGNITOR - PASSENGER AIRBAG / 1  
 IGNITOR - PASSENGER AIRBAG / 2  
 IGNITOR - RH SEAT BELT PRETENSIONER  
 IGNITOR - SIDE AIRBAG, DRIVER  
 IGNITOR - SIDE AIRBAG, PASSENGER  
 IGNITORS - DRIVER AIRBAG

OCCUPANCY SENSING MODULE  
 OCCUPANCY SENSOR - CONSOLE  
 OCCUPANCY SENSOR - LH 'A' POST (RHD)  
 OCCUPANCY SENSOR - LH 'B' POST (RHD)  
 OCCUPANCY SENSOR - RH 'A' POST (LHD)  
 OCCUPANCY SENSOR - RH 'B' POST (LHD)  
 PASSENGER AIRBAG DEACTIVATED INDICATOR LAMP  
 PASSENGER SEAT BELT SWITCH  
 PASSENGER SEAT WEIGHT PRESSURE SENSOR  
 PASSENGER SEAT WEIGHT SENSING MODULE  
 RESTRAINTS CONTROL MODULE

**Connector / Type / Color**

LF50 / 2-WAY CONNECTOR / BLACK  
 RH15 / 2-WAY CONNECTOR / BLACK  
 RH16 / 2-WAY CONNECTOR / BLACK  
 SD20 / 6-WAY MULTILOCK 040 / WHITE  
 SD21 / 2-WAY CONNECTOR / BLACK  
 PT2 / 2-WAY FORD AIRBAG / YELLOW  
 FC75 / 2-WAY CONNECTOR / BLACK  
 FC76 / 2-WAY CONNECTOR / BLACK  
 PT3 / 2-WAY FORD AIRBAG / YELLOW  
 SD15 / 2-WAY CONNECTOR / BROWN  
 SP15 / 2-WAY CONNECTOR / BROWN  
 SW12 / 2-WAY CONNECTOR / GREY  
 SW13 / 2-WAY CONNECTOR / BLACK  
 FC10 / 26-WAY AMP MQL / YELLOW  
 RZ2 / 4-WAY MULTILOCK 070 / WHITE  
 RZ3 / 4-WAY CONNECTOR / BLACK  
 RH10 / 4-WAY MULTILOCK 070 / WHITE  
 RF3 / 4-WAY CONNECTOR / BLACK  
 RH11 / 4-WAY MULTILOCK 070 / WHITE  
 FC15 / 3-WAY CONNECTOR / BLACK  
 SP20 / 6-WAY MULTILOCK 040 / WHITE  
 SP18 / 3-WAY CONNECTOR / BLACK  
 SP21 / 2-WAY METRI-PACK 150 / BLACK  
 FC8 / 24-WAY CONNECTOR / BLACK  
 FC9 / 40-WAY CONNECTOR / BLACK

**Location / Access**

FORWARD OF RADIATOR  
 BEHIND SAFETY BELT RETRACTOR / REAR QUARTER TRIM PANEL  
 BEHIND SAFETY BELT RETRACTOR / REAR QUARTER TRIM PANEL  
 BELOW SEAT CUSHION  
 BELOW SEAT CUSHION  
 BEHIND LH REAR QUARTER TRIM PANEL  
 SIDE OF AIRBAG ASSEMBLY  
 SIDE OF AIRBAG ASSEMBLY  
 BEHIND LH REAR QUARTER TRIM PANEL  
 SEAT BACK  
 SEAT BACK  
 CENTER OF STEERING WHEEL  
 CENTER OF STEERING WHEEL  
 'A' POST / RH SIDE OF FASCIA  
 BEHIND ROOF CONSOLE  
 UPPER LH 'A' POST / 'A' POST TRIM  
 'B' POST (COUPE); REAR QUARTER (CONV.) / TRIM  
 UPPER RH 'A' POST / 'A' POST TRIM  
 'B' POST (COUPE); REAR QUARTER (CONV.) / TRIM  
 PASSENGER SIDE FASCIA  
 BELOW SEAT CUSHION  
 BELOW SEAT CUSHION  
 BELOW SEAT CUSHION  
 CENTER CONSOLE

**HARNESSTO-HARNESSTO CONNECTORS****Connector**

LF2  
 PT1  
 RF5  
 RH9  
 RZ1  
 SD1  
 SD13  
 SP1  
 SP13  
 SW10

**Type / Color**

8-WAY FORD AIRBAG / NATURAL  
 4-WAY MULTILOCK 070 / WHITE  
 8-WAY MULTILOCK 070 / WHITE  
 20-WAY MULTILOCK 070 / YELLOW  
 8-WAY MULTILOCK 070 / YELLOW  
 14-WAY MULTILOCK 070 / YELLOW  
 3-WAY EPC / BLACK  
 14-WAY MULTILOCK 070 / YELLOW  
 3-WAY EPC / BLACK  
 4-WAY CONNECTOR / GREY

**Location / Access**

LEFT HAND 'A' POST CONNECTOR MOUNTING BRACKET / 'A' POST TRIM  
 BELOW CENTER CONSOLE ASSEMBLY  
 LOWER RH 'A' POST / 'A' POST TRIM  
 BELOW CENTER CONSOLE  
 LOWER LH 'A' POST / 'A' POST TRIM  
 BELOW DRIVER SEAT  
 BELOW SEAT CUSHION  
 BELOW PASSENGER SEAT  
 BELOW SEAT CUSHION  
 INSIDE STEERING COLUMN COWL

**GROUNDS****Ground**

FC1S

**Location / Type**

EYELET (SINGLE) / TRANSMISSION TUNNEL, RIGHT HAND SIDE

Refer to the front of this book for detailed information and illustrations regarding the location and identification of harnesses, relays, grounds, control modules and control module pins.





NOTE: The CAN Network connecting the three SRS Control Modules is a local CAN Network. It is not part of the Powertrain CAN.

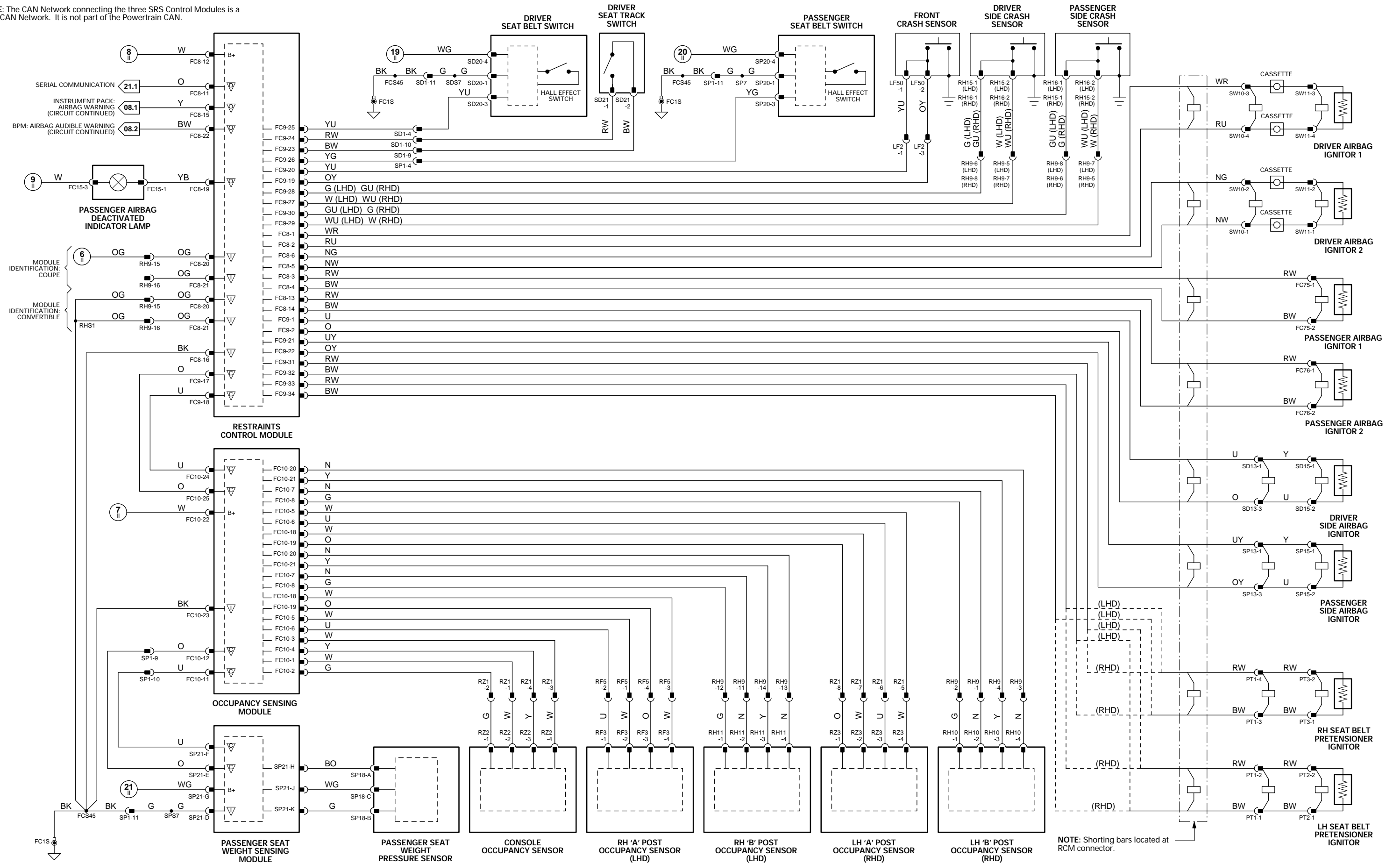

NOTE: Shorting bars located at RCM connector.

**Fig. 19.1****COMPONENTS****Component**

PARKING AID SENSOR – CENTER LH  
PARKING AID SENSOR – CENTER RH  
PARKING AID SENSOR – LH  
PARKING AID SENSOR – RH  
PARKING AID SOUNDER  
REVERSE PARKING AID CONTROL MODULE

**Connector / Type / Color**

RB3 / 3-WAY AMP MQL / BLACK  
RB4 / 3-WAY AMP MQL / BLACK  
RB2 / 3-WAY AMP MQL / BLACK  
RB5 / 3-WAY AMP MQL / BLACK  
RH4 / 2-WAY MULTILOCK 070 / WHITE  
BT4 / 16-WAY CONNECTOR / WHITE  
RB1 / 12-WAY CONNECTOR / WHITE

**Location / Access**

BEHIND REAR BUMPER  
BEHIND REAR BUMPER  
BEHIND REAR BUMPER  
BEHIND REAR BUMPER  
BELOW CENTER CONSOLE GLOVE BOX  
TRUNK / SPARE WHEEL WELL  
TRUNK / SPARE WHEEL WELL

**HARNESS-TO-HARNESS CONNECTORS****Connector**

BT1

**Type / Color**

20-WAY MULTILOCK 070 / WHITE

**Location / Access**

TRUNK / ABOVE RIGHT HAND REAR WHEEL ARCH

**GROUNDS****Ground**

BT3S

**Location / Type**

EYELET (SINGLE) / TRUNK, LEFT REAR

Refer to the front of this book for detailed information and illustrations regarding the location and identification of harnesses, relays, grounds, control modules and control module pins.

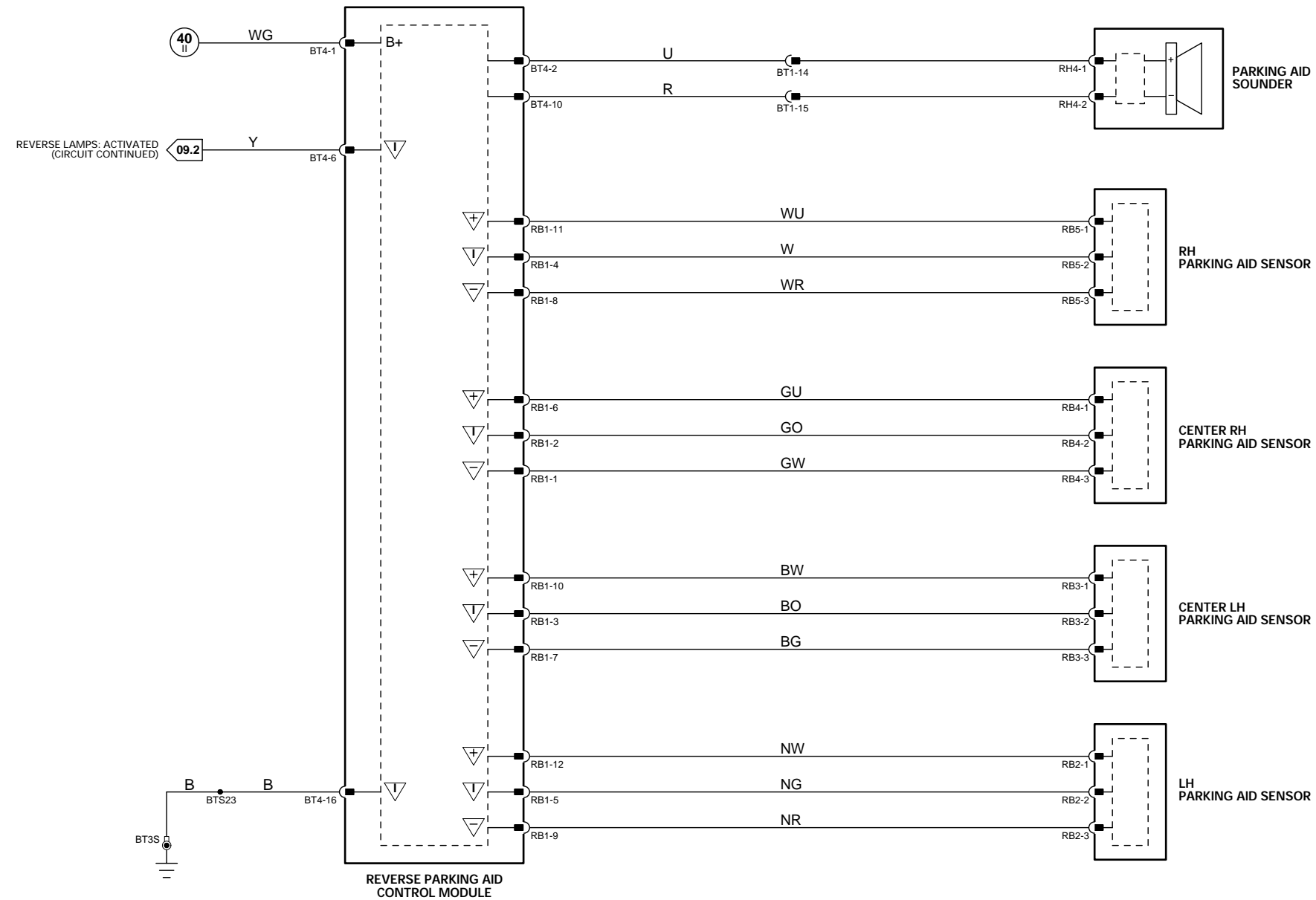

**CONTROL MODULE PIN OUT INFORMATION**

**BODY PROCESSOR MODULE**

Pin	Description	Active	Inactive
I	FC14-4	BATTERY POWER SUPPLY	B+
O	FC14-70	HORN RELAY ACTIVATE	B+
I	FC14-80	BATTERY POWER SUPPLY (LOGIC)	B+

**Fig. 20.1**

**COMPONENTS**

Component	Connector / Type / Color	Location / Access
BODY PROCESSOR MODULE CIGAR LIGHTER	FC14 / 104-WAY AMP EEEC / GREY FC42 / 2-WAY AMP / METALLIC FC59 / LUCAR POSILOCK / BLACK FC51 / 3-WAY AMP SERIES 250 / BLACK	PASSENGER SIDE FASCIA / AIRBAG BRACKET FORWARD OF GEAR SELECTOR
FASCIA ACCESSORY CONNECTOR FUZE BOX - ENGINE COMPARTMENT	LF5 / 10-WAY U.T.A. FUSEBOX / NATURAL LF6 / 10-WAY U.T.A. FUSEBOX / BLACK LF7 / 10-WAY U.T.A. FUSEBOX / GREEN LF8 / 10-WAY U.T.A. FUSEBOX / BLUE LF70 / EYELET	FASCIA / ADJACENT TO RIGHT HAND SIDE OF GLOVE BOX ENGINE COMPARTMENT / LEFT FRONT
FUZE BOX - TRUNK	BT10 / 10-WAY U.T.A. FUSEBOX / NATURAL BT11 / 10-WAY U.T.A. FUSEBOX / BLACK BT12 / 10-WAY U.T.A. FUSEBOX / GREEN BT13 / 10-WAY U.T.A. FUSEBOX / BLUE BT64 / EYELET	TRUNK / ELECTRICAL CARRIER
GARAGE DOOR OPENER (ROOF CONSOLE)	RF11 / HYBRID / WHITE RF10 / 6-WAY MULTILOCK 070 / GREY	ROOF CONSOLE
HORN SWITCHES (STEERING WHEEL)	HP1 / 1-WAY BLADE / METALLIC HP2 / 1-WAY BLADE / METALLIC HP3 / EYELET	CENTER OF STEERING WHEEL
HORN - LH	LF16 / LUCAR POSILOCK / BLACK LF17 / LUCAR POSILOCK / BLACK	FRONT BUMPER / REAR
HORN - RH	LF14 / LUCAR POSILOCK / BLACK LF15 / LUCAR POSILOCK / BLACK	FRONT BUMPER / REAR
TRUNK ACCESSORY CONNECTOR	BT25 / 3-WAY AMP SERIES 250 PIN / BLACK	TRUNK / ADJACENT TO BATTERY

**RELAYS**

Relay	Color / Stripe	Connector / Color	Location / Access
HORN RELAY (#6)	BROWN	BUS	ENGINE COMPARTMENT FUZE BOX
ACCESSORY CONNECTOR RELAY (#6)	BROWN	BUS	TRUNK FUZE BOX

**HARNESS-TO-HARNESS CONNECTORS**

Connector	Type / Color	Location / Access
BT58	4-WAY ECONOSEAL III HC / BLACK	TRUNK / ABOVE RIGHT HAND REAR WHEEL ARCH
LF60	20-WAY MULTILOCK 070 / WHITE	LEFT HAND 'A' POST CONNECTOR MOUNTING BRACKET / 'A' POST TRIM
RF5	8-WAY MULTILOCK 070 / WHITE	LOWER RH 'A' POST / 'A' POST TRIM
RH14	2-WAY ECONOSEAL III HC / BLACK	REAR OF CENTER CONSOLE ASSEMBLY
SC2	10-WAY MULTILOCK 070 / YELLOW	ADJACENT TO STEERING COLUMN MOTOR
SC3	12-WAY MULTILOCK 070 / GREY	RIGHT HAND SIDE OF STEERING COLUMN
SW1	12-WAY MULTILOCK 040 / BLACK	INSIDE STEERING COLUMN COWL
SW2	6-WAY JST / WHITE	CENTER OF STEERING WHEEL

**GROUND**

Ground	Location / Type
BT2BR	EYELET (PAIR) - RIGHT HAND LEG / TRUNK, RIGHT REAR
BT2BS	EYELET (SINGLE) - TRUNK, RIGHT REAR
FC2BL	EYELET (PAIR) - LEFT HAND LEG / RIGHT HAND 'A' POST
FC2BR	EYELET (PAIR) - RIGHT HAND LEG / RIGHT HAND 'A' POST
FC3BL	EYELET (PAIR) - LEFT HAND LEG / TRANSMISSION TUNNEL, LEFT HAND SIDE
FC3BR	EYELET (PAIR) - RIGHT HAND LEG / TRANSMISSION TUNNEL, LEFT HAND SIDE
FC4BL	EYELET (PAIR) - LEFT HAND LEG / LEFT HAND 'A' POST
FC4BR	EYELET (PAIR) - RIGHT HAND LEG / LEFT HAND 'A' POST
LF1AL	EYELET (PAIR) - LEFT HAND LEG / RIGHT HAND HEADLAMP
LF2BR	EYELET (PAIR) - RIGHT HAND LEG / ENGINE COMPARTMENT, FORWARD OF LEFT HAND HOOD LATCH

FOR CONTROL MODULE PIN OUT INFORMATION, UNFOLD PAGE TO LEFT.

The following abbreviations are used to represent values for Control Module Pin-Out data

I	Input	SG	Sensor Ground	S	SCP Network	V	Voltage (DC)
O	Output	A	ACP Network	D	Serial and Encoded Data	Hz	Frequency
SS	Sensor Supply V	C	CAN (Network)	B+	Battery Voltage	kHz	Frequency x 1000

CAUTION: The information on this data page is furnished to aid the user in understanding circuit operation. THIS INFORMATION SHOULD BE USED FOR REFERENCE ONLY.

NOTE: The values listed are approximately those that can be expected at the control module connector pins with all circuit connections made and all components connected and fitted. "Active" means a load is applied or a switch is ON; "Inactive" means a load is not applied or a switch is OFF.

Refer to the front of this book for detailed information and illustrations regarding the location and identification of harnesses, relays, grounds, control modules and control module pins.

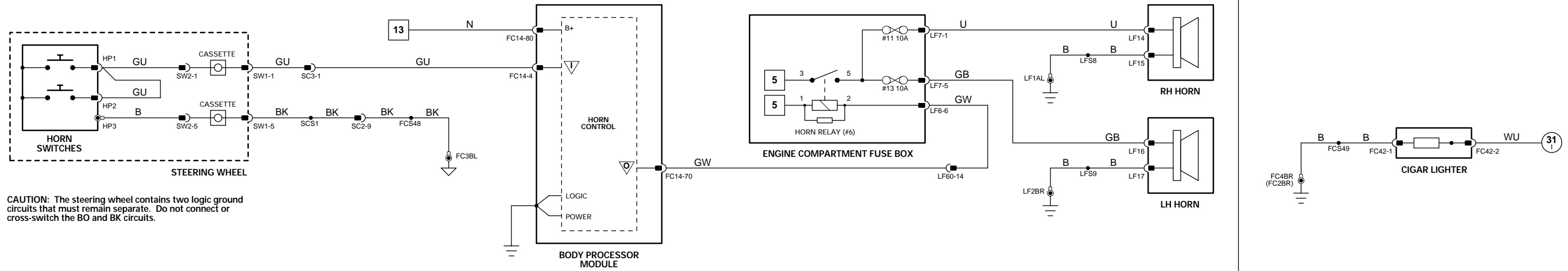

**CAUTION:** The steering wheel contains two logic ground circuits that must remain separate. Do not connect or cross-switch the BO and BK circuits.

HORNS

CIGAR LIGHTER

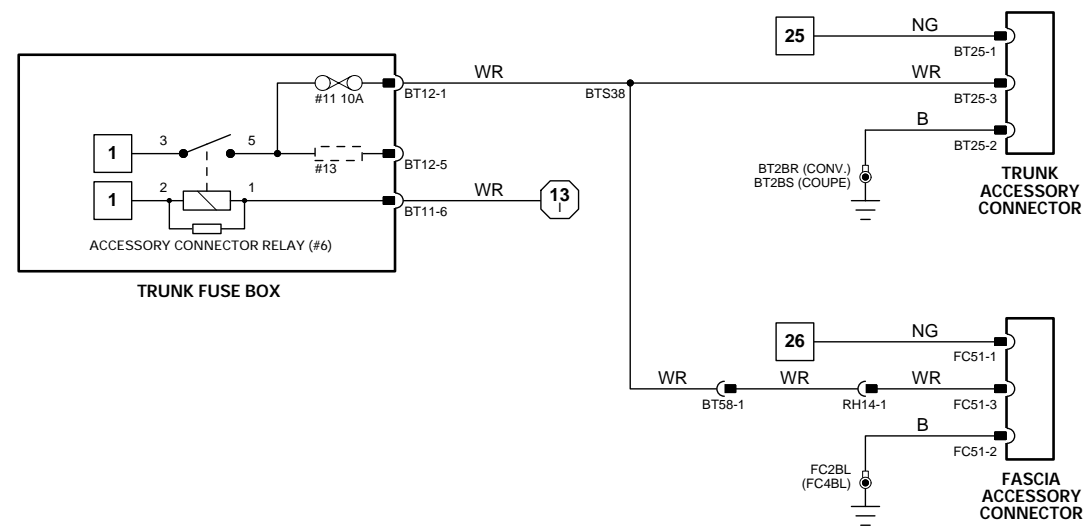

ACCESSORY CONNECTORS

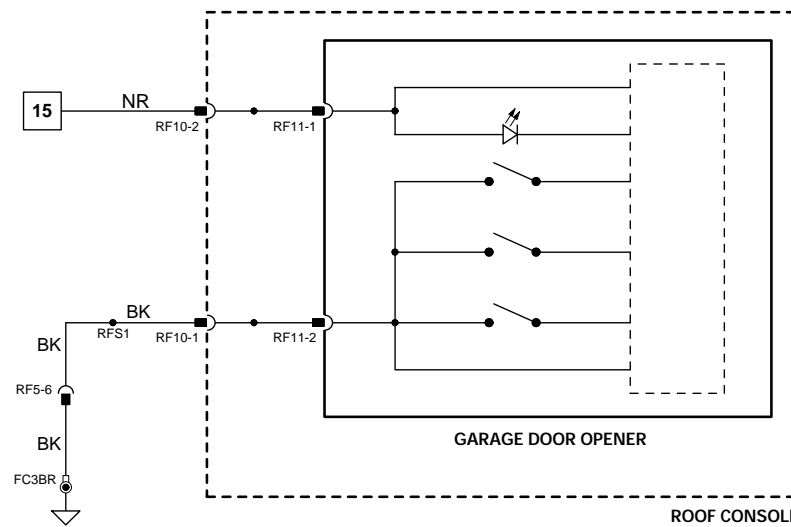

GARAGE DOOR OPENER

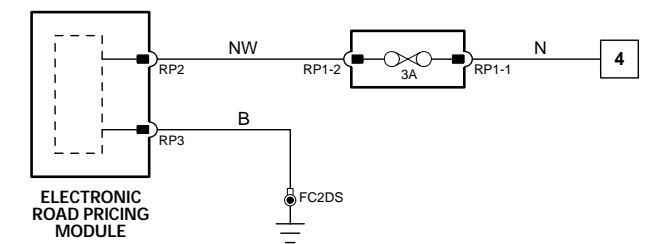

ELECTRONIC ROAD PRICING

**Fig. 21.1**

**COMPONENTS**

**Component**

ABS / TRACTION CONTROL CONTROL MODULE  
ACTIVE SECURITY SOUNDER  
ADAPTIVE DAMPING CONTROL MODULE  
ADAPTIVE SPEED CONTROL CONTROL MODULE  
AIR CONDITIONING CONTROL MODULE

BODY PROCESSOR MODULE  
DATA LINK CONNECTOR  
DOOR CONTROL MODULE – DRIVER

DOOR CONTROL MODULE – PASSENGER

ENGINE CONTROL MODULE

GEAR SELECTOR ILLUMINATION MODULE  
HEAD RESTRAINT CONTROL MODULE – DRIVER  
HEAD RESTRAINT CONTROL MODULE – PASSENGER  
KEY TRANSPONDER MODULE  
MAJOR INSTRUMENT PACK

RESTRAINTS CONTROL MODULE

SEAT CONTROL MODULE – DRIVER

SEAT CONTROL MODULE – PASSENGER

SECURITY AND LOCKING CONTROL MODULE

TRANSMISSION CONTROL MODULE: AJ27 N/A  
TRANSMISSION CONTROL MODULE: AJ27 SC

**Connector / Type / Color**

LF37 / 25-WAY AMP HYBRID / BLACK  
LF18 / 6-WAY ECONOSEAL III LC / BLACK  
BT69 / 35-WAY AMP / BLACK  
LF61 / 12-WAY ECONOSEAL III LC / BLACK  
AC1 / 26-WAY MULTILOCK 47 / GREY  
AC2 / 16-WAY MULTILOCK 47 / GREY  
AC3 / 12-WAY MULTILOCK 47 / GREY  
AC4 / 22-WAY MULTILOCK 47 / GREY  
FC14 / 104-WAY AMP EEEEC / GREY  
FC53 / 16-WAY AMP OBD2 / BLACK  
DD10 / 22-WAY FORD 2.8 TIMER / BLUE  
DD11 / 22-WAY FORD 2.8 TIMER / BLACK  
DP10 / 22-WAY FORD 2.8 TIMER / BLUE  
DP11 / 22-WAY FORD 2.8 TIMER / BLACK  
EM80 / 31-WAY AMP 403 / NATURAL  
EM81 / 24-WAY AMP 403 / NATURAL  
EM82 / 17-WAY AMP 403 / NATURAL  
EM83 / 28-WAY AMP 403 / NATURAL  
EM84 / 22-WAY AMP 403 / NATURAL  
EM85 / 12-WAY MULTILOCK 070 / WHITE  
FC88 / 10-WAY MULTILOCK 070 / WHITE  
SD22 / 16-WAY FORD IDC / BLACK  
SP22 / 16-WAY FORD IDC / BLACK  
FC22 / 20-WAY MULTILOCK 040 / GREEN  
FC25 / 26-WAY AMP MICRO QUAD LOCK / BLACK  
FC26 / 26-WAY AMP MICRO QUAD LOCK / YELLOW  
FC8 / 24-WAY CONNECTOR / BLACK  
FC9 / 40-WAY CONNECTOR / BLACK  
SD3 / 16-WAY FORD 2.8 TIMER / BLACK  
SD4 / 26-WAY FORD IDC / BLACK  
SD5 / 10-WAY FORD 2.8 TIMER / BLACK  
SP3 / 16-WAY FORD 2.8 TIMER / BLACK  
SP5 / 10-WAY FORD 2.8 TIMER / BLACK  
BT40 / 16-WAY FORD 2.8 TIMER / BLACK  
BT41 / 26-WAY FORD IDC / BLACK  
BT42 / 10-WAY FORD 2.8 TIMER / BLACK  
RH20 / COAXIAL CONNECTOR  
EM7 / 88-WAY BOSCH / BLACK  
EM72 / 14-WAY AMP JUNIOR POWER TIMER / BLACK  
EM73 / 18-WAY AMP JUNIOR POWER TIMER / BLACK

**Location / Access**

ENGINE COMPARTMENT / FRONT LEFT  
REARWARD OF RIGHT FRONT HEADLAMP  
TRUNK / ADJACENT TO ELECTRICAL CARRIER  
ENGINE COMPARTMENT / FORWARD OF RADIATOR  
A/C UNIT / RIGHT HAND SIDE  
  
PASSENGER SIDE FASCIA / AIRBAG BRACKET  
BELOW DRIVER SIDE FUSE BOX  
DRIVER DOOR / DOOR CASING  
  
PASSENGER DOOR / DOOR CASING  
  
ENGINE COMPARTMENT / CONTROL MODULE ENCLOSURE  
  
FRONT OF GEAR SELECTOR ASSEMBLY  
BEHIND SEAT BACK FINISHER  
BEHIND SEAT BACK FINISHER  
ADJACENT TO DRIVER SIDE FUSE BOX  
FASCIA  
  
CENTER CONSOLE  
  
BELOW SEAT CUSHION  
  
BELOW SEAT CUSHION  
  
TRUNK / ELECTRICAL CARRIER  
  
ENGINE COMPARTMENT / CONTROL MODULE ENCLOSURE  
ENGINE COMPARTMENT / CONTROL MODULE ENCLOSURE

**HARNESS-TO-HARNESS CONNECTORS**

**Connector**

**Type / Color**

AC14 14-WAY MULTILOCK 070 / GREY  
BT1 20-WAY MULTILOCK 070 / WHITE  
BT2 20-WAY MULTILOCK 070 / WHITE  
DD1 23-WAY AMP – FORD / BLACK  
DP1 23-WAY AMP – FORD / BLACK  
EM1 20-WAY MULTILOCK 070 / WHITE  
LF1 20-WAY MULTILOCK 070 / GREY  
LF40 13-WAY ECONOSEAL III LC / BLACK  
  
RH2 20-WAY MULTILOCK 070 / WHITE  
RH12 18-WAY MULTILOCK 070 / YELLOW  
SD1 14-WAY MULTILOCK 070 / YELLOW  
SP1 14-WAY MULTILOCK 070 / YELLOW

**Location / Access**

FASCIA BOTTOM CONNECTOR MOUNTING BRACKET / RIGHT HAND SIDE  
TRUNK / ABOVE RIGHT HAND REAR WHEEL ARCH  
TRUNK / ABOVE RIGHT HAND REAR WHEEL  
DRIVER SIDE 'A' POST MOUNTING BRACKET / 'A' POST TRIM  
PASSENGER SIDE 'A' POST / 'A' POST TRIM  
ENGINE COMPARTMENT / ADJACENT TO RIGHT HAND ENCLOSURE  
LEFT HAND 'A' POST CONNECTOR MOUNTING BRACKET / 'A' POST TRIM  
LHD: ENGINE COMPARTMENT / FORWARD OF BRAKE FLUID RESERVOIR  
RHD: ENGINE COMPARTMENT / BELOW CONTROL MODULE ENCLOSURE  
REAR OF CENTER CONSOLE ASSEMBLY  
REAR OF CENTER CONSOLE ASSEMBLY  
BELOW DRIVER SEAT  
BELOW PASSENGER SEAT

**GROUND**

**Ground**

**Location / Type**

FC3BL EYELET (PAIR) – LEFT HAND LEG / TRANSMISSION TUNNEL, LEFT HAND SIDE

**NOTE:** Refer to the Appendix at the rear of this book for CAN and SCP Network Messages.

The following abbreviations are used to represent values for Control Module Pin-Out data

I	Input	SG	Sensor Ground	S	SCP Network	V	Voltage (DC)
O	Output	A	ACP Network	D	Serial and Encoded Data	Hz	Frequency
SS	Sensor Supply V	C	CAN (Network)	B+	Battery Voltage	kHz	Frequency x 1000

**CAUTION:** The information on this data page is furnished to aid the user in understanding circuit operation. THIS INFORMATION SHOULD BE USED FOR REFERENCE ONLY.

**NOTE:** The values listed are approximately those that can be expected at the control module connector pins with all circuit connections made and all components connected and fitted. "Active" means a load is applied or a switch is ON; "Inactive" means a load is not applied or a switch is OFF.

Refer to the front of this book for detailed information and illustrations regarding the location and identification of harnesses, relays, grounds, control modules and control module pins.

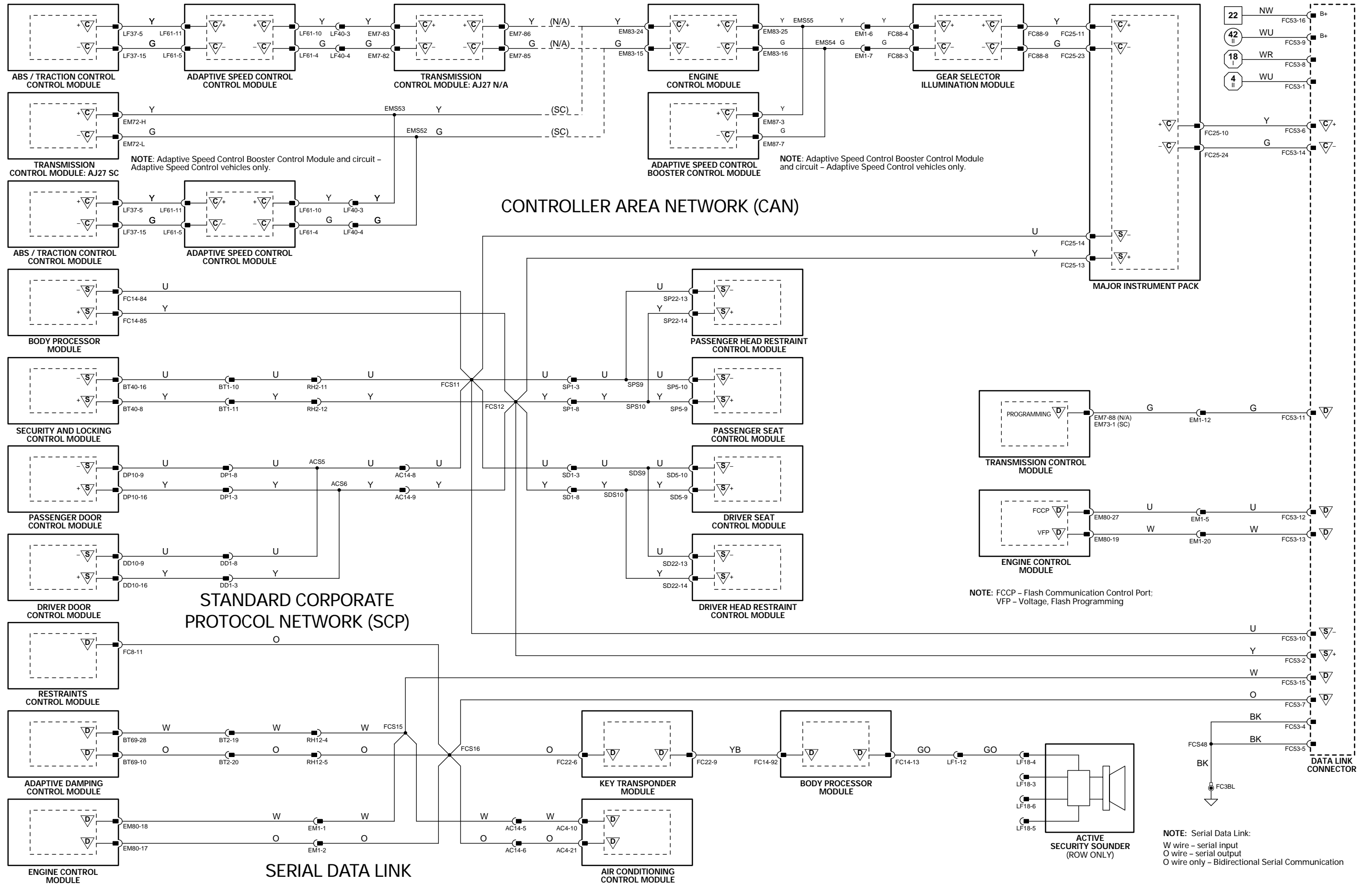

1 → 7 Fig. 01.1    1 → 5 Fig. 01.1    8 → 50 Fig. 01.2    51 → 90 Fig. 01.3    6 → 58 Fig. 01.4    59 → 73 Fig. 01.5    1 → 18 Fig. 02.1

▽ Input    ▽ Sensor Supply V    ▽ ACP    ▽ SCP  
 ▽ Output    ▽ Sensor Ground    ▽ CAN    ▽ Serial and Encoded Data

**VARIANT:** All Vehicles  
**VIN RANGE:** A11051 →  
**DATE OF ISSUE:** September 2000







This Appendix contains a listing of CAN and SCP Network messages.

## Abbreviations

The following abbreviations are used throughout this Appendix:

ABS/TCCM	Anti-Lock Braking / Traction Control Control Module
BPM	Body Processor Module
DIAG	Diagnostics
DDCM	Driver Door Control Module
DSCM	Driver Seat Control Module
ECM	Engine Control Module
INST	Instrument Pack
J-GATE	Gear Selector Illumination Module
PDCM	Passenger Door Control Module
PSCM	Passenger Seat Control Module
R	Receive
T	Transmit
TCM	Transmission Control Module
SCCM	Adaptive Speed Control Control Module
SCBCM	Adaptive Speed Control Booster Control Module
SLCM	Security and Locking Control Module



## CAN Message Matrix

Message / Function	Source	Receivers								
		ECM	TCM	ABS/TCCM	INST	J-GATE	SCCM	SCBCM	DIAG	
CAN traction acknowledge	ECM		X							
CAN traction control estimated engine torque	ECM		X							
CAN set speed	ECM						X			
CAN target speed	ECM						X			
CAN shift energy management estimated engine torque	ECM		X	X						
CAN throttle position	ECM		X	X						
CAN pedal position	ECM		X	X			X			
CAN torque reduction acknowledge	ECM		X							
CAN engine speed	ECM		X	X	X					
CAN brake pedal pressed	ECM			X	X		X	X		
CAN ECM adaptive speed control fail	ECM						X			
CAN speed control status	ECM		X				X			
CAN parking brake status	ECM				X					
CAN OBD II clear fault codes	ECM		X	X						
CAN headway increment	ECM						X			
CAN cancel request	ECM						X			
CAN engine coolant temperature	ECM		X		X					
CAN engine OBD II MIL	ECM			X	X					
CAN throttle malfunction red	ECM			X	X					
CAN throttle malfunction amber	ECM			X	X					
CAN ECM fault code MIL status	ECM			X						
CAN ECM PECUS flag	ECM				X					
CAN engine fault codes	ECM			X						
CAN fuel used	ECM				X					
CAN barometric pressure	ECM		X							
CAN torque reduction request	TCM	X								
CAN transmission overload	TCM	X								
CAN transmission input speed	TCM	X		X						
CAN transmission output speed	TCM	X		X						



Message / Function	Source	Receivers								
		ECM	TCM	ABS/TCCM	INST	J-GATE	SCCM	SCBCM	DIAG	
CAN torque converter slip	TCM	X		X						
CAN kickdown	TCM	X		X						
CAN gear position actual	TCM	X		X						
CAN torque converter status	TCM	X		X						
CAN gear position selected	TCM	X			X	X				
CAN gear selection fault	TCM	X			X	X				
CAN transmission shift map	TCM	X		X			X			
CAN transmission oil temperature	TCM	X			X					
CAN transmission malfunction	TCM	X		X	X					
CAN TCM PECUS flag	TCM				X					
CAN gear position target (not used)	TCM			X						
CAN torque transfer in progress (not used)	TCM			X						
CAN TCM fault code MIL status	TCM	X								
CAN OBD II TCM clear acknowledge	TCM	X								
CAN transmission fault codes	TCM	X		X						
CAN torque reduction throttle	ABS/TCCM	X								
CAN fast torque reduction ignition	ABS/TCCM	X								
CAN fast torque reduction cylinder	ABS/TCCM	X								
CAN traction status	ABS/TCCM	X			X					
CAN traction shift map	ABS/TCCM		X							
CAN ABS PECUS flag	ABS/TCCM				X					
CAN vehicle reference speed	ABS/TCCM	X			X					
CAN reference distance traveled	ABS/TCCM				X					
CAN ABS fault codes	ABS/TCCM	X								
CAN OBD II ABS clear acknowledge	ABS/TCCM	X								
CAN ABS fault code MIL status	ABS/TCCM	X								
CAN ABS malfunction	ABS/TCCM	X			X			X		
CAN ABS status	ABS/TCCM							X		
CAN front left wheel speed	ABS/TCCM	X	X				X	X		



## CAN Message Matrix

Message / Function	Source	Receivers								
		ECM	TCM	ABS/TCCM	INST	J-GATE	SCCM	SCBCM	DIAG	
CAN front right wheel speed	ABS/TCCM	X	X				X	X		
CAN rear left wheel speed	ABS/TCCM	X	X				X			
CAN rear right wheel speed	ABS/TCCM	X	X		X		X			
CAN sidelight status	INST	X								
CAN dipped beam status	INST	X								
CAN main beam status	INST	X								
CAN oil pressure low	INST	X								
CAN indicator right	INST						X			
CAN indicator left	INST						X			
CAN trip units	INST	X					X			
CAN fuel level damped	INST	X								
CAN fuel level raw	INST	X								
CAN display commands	SCCM				X					
CAN headway setting	SCCM				X					
CAN follow warning light	SCCM				X					
CAN extra bong	SCCM				X					
CAN display set speed	SCCM				X					
CAN follow speed	SCCM	X								
CAN brake demand pressure	SCCM							X		
CAN adaptive speed control status	SCCM				X					
CAN adaptive speed control PECUS flag	SCCM				X					
CAN brake booster enable	SCCM							X		
CAN brake actual pressure	SCBCM						X			
CAN brake demand pressure acknowledge	SCBCM						X			
CAN SBU status	SCBCM						X			
CAN diagnostic data in acknowledge	DIAG						X			
CAN diagnostic data out acknowledge	SCCM								X	
CAN diagnostic data in SCBCM	DIAG							X		
CAN diagnostic data out SCBCM	SCBCM								X	





SCP Message Matrix

#	Message Name	INST	BPM	DDCM	PDCM	DSCM	PSCM	SLCM
1	Vehicle speed	T	R	R				R
2	Brake pedal pressed	T	R					
3	SLCM not programmed	R						T
4	BPM not programmed	R	T					
5	DDCM not programmed	R		T				
6	DSCM not programmed	R				T		
7	PDCM not programmed	R			T			
8	PSCM not programmed	R					T	
9	Left hand drive vehicle		T	R	R			R
10	Valet mode OFF		T					R
11	Non-convertible vehicle		T					R
12	Right hand drive vehicle		T	R	R			R
13	Valet mode ON		T					R
14	Convertible vehicle		T					R
15	Request vehicle drive side		R	T				
16	Request valet mode status		R					T
17	Request convertible status		R					T
18	Reverse gear selected	T	R	R	R	R	R	R
19	Not-in-park switch – inactive		T	R	R	R	R	
20	Not-in-park switch – active		T	R	R	R	R	
21	Request not-in-park switch status		R			T		
22	Request not-in-park switch status		R				T	
23–58	Diagnostic messages							
59	Charging OK	T				R	R	
60	Inertia switch inactive		T	R	R			R
61	Inertia switch active		T	R	R			R
62	Request inertia switch status		R	T				
63	Request inertia switch status		R		T			
64	Ignition status	R	T	R	R	R	R	R
65	Key not-in-ignition		T	R	R			R
66	Key in-ignition		T	R	R			R
67	Request ignition status		R					T
68	Request ignition status	T	R					
69	Request ignition status		R	T				
70	Request ignition status		R			T		
71	Request ignition status		R		T			
72	Request ignition status		R				T	
73	Request key-in status		R					T
74	Request key-in status		R	T				
75	Request key-in status		R			T		
76	Request key-in status		R			T		
77	Seat belt telltale OFF	R				T		
78	Low washer fluid warning OFF	R	T					
79	Convertible top latch warning OFF	R						T
80	Seat belt telltale ON	R				T		
81	Low washer fluid warning ON	R	T					
82	Convertible top latch warning ON	R						T
83	Request washer fluid status	T	R					
84	Request convertible top latch status	T						R
85	Security audible indication		R					T
86	Remote panic		R	R	R			T
87	Security disarm		R	R	R			T
88	Glass break fault		T					R
89	Security armed		R	R	R			T



#	Message Name	INST	BPM	DDCM	PDCM	DSCM	PSCM	SLCM
90	Key valid		T					R
91	Glass break detected		T					R
92	Request security arm status		T					R
93	Request security arm status			T				R
94	Request security arm status				T			R
95	Seat belt chime OFF		R			T		
96	Seat belt chime ON		R			T		
97	Request seat belt chime status		T			R		
98-165	Diagnostic messages							
166	Recall memory 1		R	T	R	R		
167	Recall memory 2		R	T	R	R		
168	Save memory 1		R	T	R	R		
169	Save memory 2		R	T	R	R		
170	DDCM memory 1 recalled		R	T				
171	DSCM memory 1 recalled		R			T		
172	PDCM memory 1 recalled		R		T			
173	DDCM memory 2 recalled		R	T				
174	DSCM memory 2 recalled		R			T		
175	PDCM memory 2 recalled		R		T			
176	Park fold-back mirrors			T		R	R	
177	Unfold fold-back mirrors			T		R	R	
178	Stop driver mirror			T	R			
179	Stop passenger mirror			T	R			
180	Driver mirror up			T	R			
181	Passenger mirror up			T	R			
182	Driver mirror down			T	R			
183	Passenger mirror down			T	R			
184	Passenger mirror right			T	R			
185	Passenger mirror left			T	R			
186	Unlock driver door			R	T			
187	Unlock passenger door			T	R			
188	Remote unlock		R	R	R			T
189	Remote trunk release		R					T
190	Lock front doors		R	T				
191	Lock front doors		R		T			
192	Remote superlock			R	R			T
193	Superlock driver door					T		
194	Superlock passenger door			T				
195	Remote lock		R					T
196	Vehicle unlocked		R	T				R
197	Driver door unlocked		R	R	R			T
198	Passenger door unlocked		R		R			T
199	Driver lock switch status		R	T				R
200	Passenger lock switch status		R		T			R
201	Driver door unsuperlocked		R	T				
202	Passenger door unsuperlocked		R		T			
203	Vehicle locked		R	T				R
204	Driver door locked		R	R	R			T
205	Passenger door locked		R	R	R			T
206	Driver door superlocked		R	T				
207	Passenger door superlocked		R		T			
208	Request vehicle lock status			R				T
209	Request driver door lock status			T				R
210	Request passenger door status				T			R

continued...



## SCP Message Matrix

#	Message Name	INST	BPM	DDCM	PDCM	DSCM	PSCM	SLCM
211	Request driver key barrel status			R				T
212	Request driver key barrel status			R	T			
213	Request passenger key barrel status (deleted)				R			T
214	Request passenger key barrel status (deleted)			T	R			
215	Request superlock status			T	R	R		
216	Open trunk			T				R
217	Hood closed	R	T					R
218	Driver door closed	R	R	T		R		R
219	Passenger door closed	R	R			T	R	R
220	Trunk closed	R	R					T
221	Stop fuel filler flap open			T				R
222	Convertible top latch status			T				
223	Hood ajar	R	T					R
224	Driver door ajar	R	R	T		R		R
225	Passenger door ajar	R	R		T		R	R
226	Trunk ajar	R	R					T
227	Open fuel filler flap			T				R
228	Request hood ajar status			R				T
229	Request driver door ajar status			R				T
230	Request driver door status			T	R			
231	Request driver door ajar status			R		T		
232	Request passenger door ajar status				R			T
233	Request trunk ajar status			T				R
234	Request convertible top latch switches status			R				T
235	Driver seat heater telltale OFF			R		T		
236	Passenger seat heater telltale OFF			R			T	
237	Driver seat heater telltale ON			R		T		
238	Passenger seat heater telltale ON			R			T	
239	Request driver heater telltale status			T		R		
240	Request passenger heater telltale status			T			R	
241	Stop global window open		R	R	R			T
242	Stop global window close		R	R	R			T
243	Position driver window			R				T
244	Position passenger window				R			T
245	Position rear quarters		R					T
246	Driver window position			T				R
247	Passenger window position				T			R
248	Stop passenger window open			T	R			
249	Stop convertible top open			T				R
250	Stop passenger window close			T	R			
251	Stop convertible top close			T				R
252	Open passenger window			T	R			
253	Open convertible top			T				R
254	Close passenger window			T	R			
255	Close convertible top			T				R
256	Request driver window position			R				T
257	Request passenger window position				R			T
258	Request driver and passenger window switch status			R	T			
259	Driver seat heater switch active			T		R		
260	Passenger seat heater switch active			T			R	
261	Front bulb failure	R	T					
262	Rear bulb failure	R						T
263	Front bulbs OK	R	T					
264	Rear bulbs OK	R						T





#	Message Name	INST	BPM	DDCM	PDCM	DSCM	PSCM	SLCM
265	Request front bulb fail status	T	R					
266	Request rear bulb fail status	T						R
267	Rear fog lamps OFF		T					R
268	Remote headlamp convenience OFF		R					T
269	Rear fog lamps ON		T					R
270	Remote headlamp convenience ON		R					T
271	Dip beam OFF	R	T					
272	Side lamps OFF	R	T					
273	Hazard warning OFF	R	T					
274	Left DI lamp OFF	R	T					
275	Right DI lamp OFF	R	T					
276	Main beam OFF	R	T					
277	Rear fog lamps OFF		R					T
278	Main beam flash OFF		T					R
279	Request rear fog switch status		R					T
280	Request remote headlamp convenience status		T					R
281	Dip beam ON	R	T					
282	Side lamps ON	R	T					
283	Hazards ON	R	T					
284	Left DI lamp ON	R	T					
285	Right DI lamp ON	R	T					
286	Main beam ON	R	T					
287	Rear fog lamps ON		R					T
288	Main beam flash ON		T					R
289	Request dip beam status	T	R					
290	Request side lamps status	T	R					
291	Request left DI status	T	R					
292	Request right DI status	T	R					
293	Request main beam status	T	R					
294	Request hazard warning status	T	R					
295	Request rear fog lamps status		T					R
296	Interior lamps OFF	R	T					
297	Interior lamps ON	R	T					
298	Request interior lighting status	T	R					
299	Valet mode message OFF	R	T					
300	Recoding keying message OFF	R						T
301	Valet mode message	R	T					
302	Recoding keying message	R						T
303-356	Diagnostic messages							
357	Wake up (SLCM)							T
358	Wake up (BPM)		T					
359	Wake up (INST)	T						
360	Wake up (DDCM)			T				
361	Wake up (DSCM)					T		
362	Wake up (PDCM)				T			
363	Wake up (PSCM)						T	
364	Network awake (SLCM)	R	R	R	R	R	R	T
365	Network awake (BPM)	R	T	R	R	R	R	R
366	Network awake (INST)	T	R	R	R	R	R	R
367	Network awake (DDCM)	R	R	T	R	R	R	R
368	Network awake (DSCM)	R	R	R	R	T	R	R
369	Network awake (PDCM)	R	R	R	T	R	R	R

continued...



SCP Message Matrix

#	Message Name	INST	BPM	DDCM	PDCM	DSCM	PSCM	SLCM
370	Network awake (PSCM)	R .....	R .....	R .....	R .....	R .....	T .....	R .....
371	SLCM entering sleep mode	R .....	R .....	R .....	R .....	R .....	R .....	T .....
372	BPM entering sleep mode	R .....	T .....	R .....	R .....	R .....	R .....	R .....
373	INST entering sleep mode	T .....	R .....	R .....	R .....	R .....	R .....	R .....
374	DDCM entering sleep mode	R .....	R .....	T .....	R .....	R .....	R .....	R .....
375	DSCM entering sleep mode	R .....	R .....	R .....	R .....	T .....	R .....	R .....
376	PDCM entering sleep mode	R .....	R .....	R .....	T .....	R .....	R .....	R .....
377	PSCM entering sleep mode	R .....	R .....	R .....	R .....	R .....	T .....	R .....