

SERVICE

TECHNICAL BULLETIN

Oil Cooler Feed Pipe/Hose Failure –
Inspect/Replace Hose –
Service Action S846

MODEL 2004-05 MY
XK Range

VIN A39699-A41740

Remove and destroy Bulletin 303-S846, dated 10/04.
Replace with this Bulletin.
Revisions are marked with a bar and in **bold text**.

Issue:

A concern has been identified on a number of 2004-05 MY XK Range vehicles within the above VIN range. A failure can occur at the outer crimp face of the oil cooler feed pipe/hose that leads from the engine to the intermediate connector. The same problem can occur on the oil cooler return pipe/hose leading from the intermediate joint back to the engine. These conditions can result in the possibility of engine oil loss and reduced engine performance.

Action:

Inspect, at the first available opportunity, all 2004-05 MY XK range vehicle within the above VIN range. Check the feed hose/pipe leading from the engine to the intermediate connector and the oil cooler return pipe/hose from the intermediate connector back to the engine for a date code of **43 03**.

If the date code is illegible, not present, or reads **43 03** on either the engine to intermediate connector oil cooler feed pipe/hose or the oil cooler return pipe/hose, both pipe/hoses must be replaced.

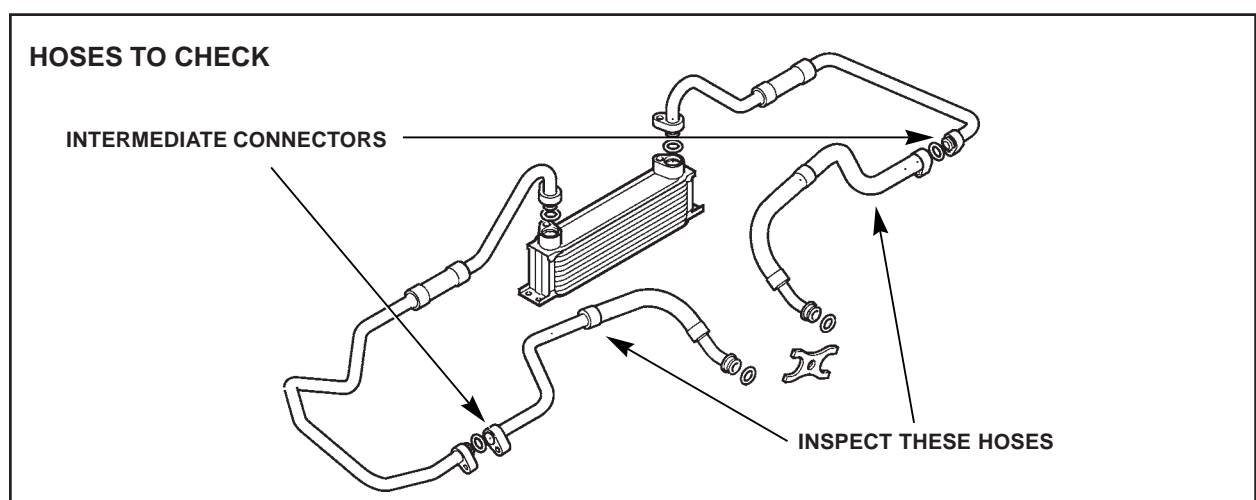

NOTE: THE INFORMATION IN TECHNICAL BULLETINS IS INTENDED FOR USE BY TRAINED, PROFESSIONAL TECHNICIANS WITH THE KNOWLEDGE, TOOLS, AND EQUIPMENT TO DO THE JOB PROPERLY AND SAFELY. IT INFORMS THESE TECHNICIANS OF CONDITIONS THAT MAY OCCUR ON SOME VEHICLES, OR PROVIDES INFORMATION THAT COULD ASSIST IN PROPER VEHICLE SERVICE. THE PROCEDURES SHOULD NOT BE PERFORMED BY "DO-IT-YOURSELFERS." DO NOT ASSUME THAT A CONDITION DESCRIBED AFFECTS YOUR CAR. CONTACT A JAGUAR RETAILER TO DETERMINE WHETHER THE BULLETIN APPLIES TO YOUR VEHICLE.

WORKSHOP PROCEDURE

1. Open door and hood and install exterior vehicle protection.
2. Raise the vehicle.

From under the vehicle:

3. Check the date code (Illustration 1) on the oil cooler feed pipe/hose running from the engine to the intermediate connector and on the oil cooler return pipe/hose from the intermediate connector back to the engine. Use a small mirror if required.

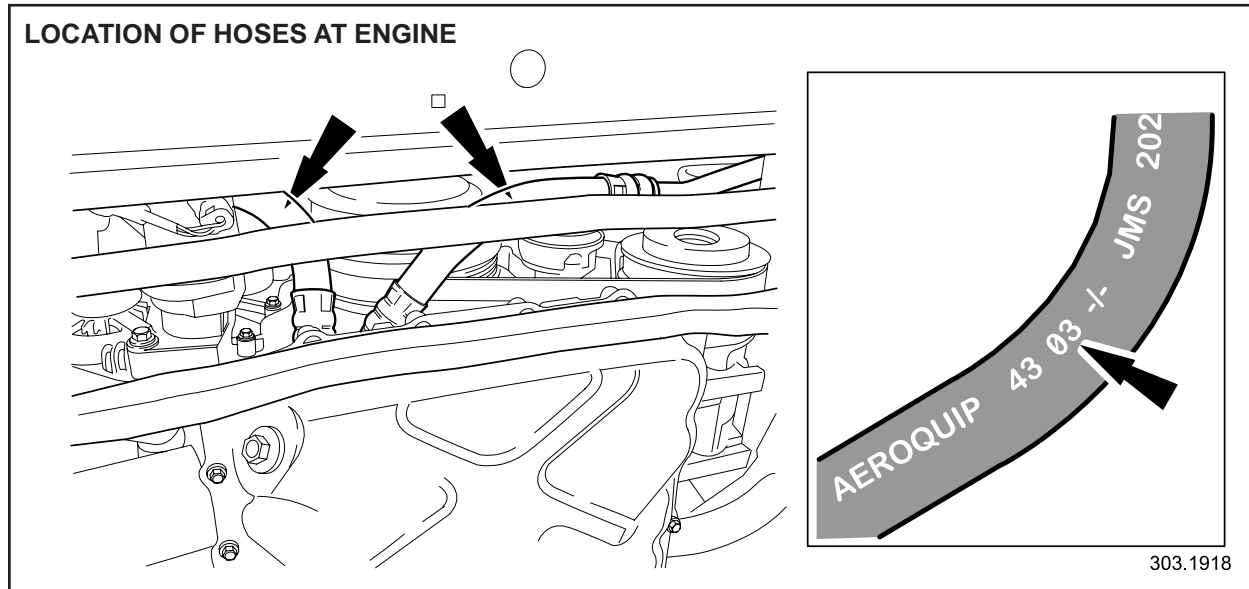

ILLUSTRATION 1

4. If the date code displayed is **43 03** or the code cannot be determined, continue to step 5 of this workshop procedure. If the date code displayed is **not 43 03**, no further action is required. Lower the vehicle.
5. Remove the undertray.
6. Place a suitable drain tray under the vehicle.
7. Remove the oil cooler pipe/hose joint retaining plate securing bolt on the front of the engine (Illustration 2).

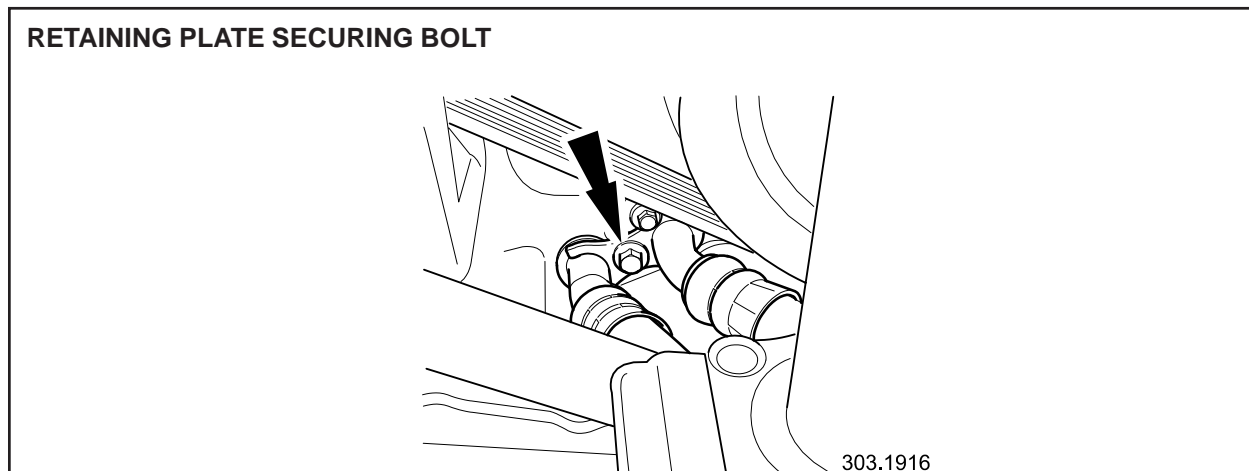
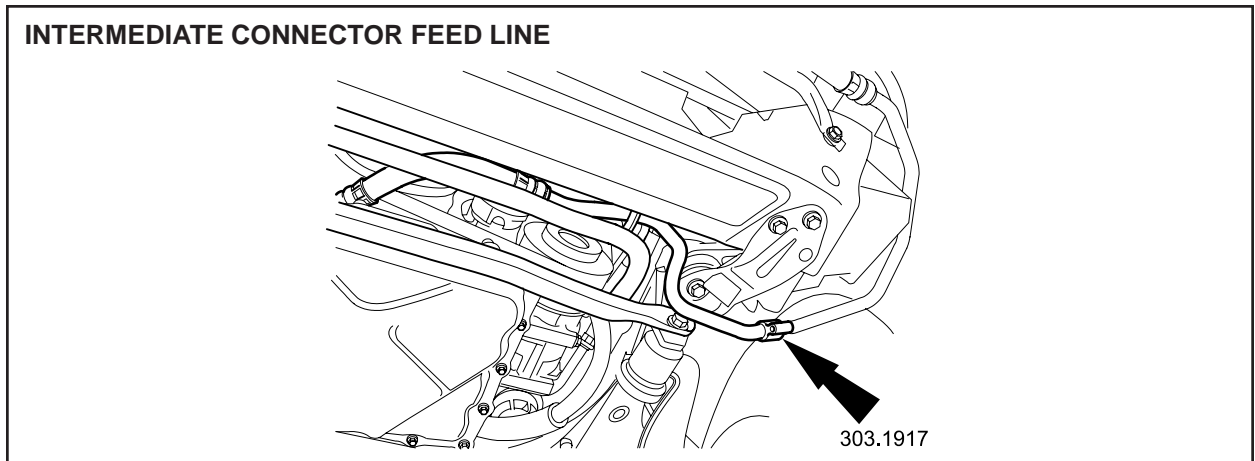

ILLUSTRATION 2

8. Remove the retaining plate.
9. Disconnect the oil cooler feed and return pipe/hoses from the front of the engine port.
10. Install suitable blanking plugs to the front of the engine port and oil cooler pipe/hoses.
11. Remove the oil cooler feed pipe/hose to intermediate connector-securing bolt (Illustration 3).



IILUSTRATION 3

12. Disconnect and remove the oil cooler feed pipe/hose from the intermediate connector.
13. Displace and discard oil cooler pipe O-ring seal.
14. Install suitable blanking plugs to cooler pipe/hoses.
15. Place the new oil cooler feed pipe/hose to the front.
16. Displace and remove the blanking plugs from the cooler pipe/hose.
17. Install and fully seat the new O-ring seal to the cooler feed pipe/hose.
18. Lubricate the new O-ring seal.
19. Reposition and align the oil cooler feed pipe/hose to the intermediate connector and re-connect.
20. Install and tighten intermediate connector securing bolt (Illustration 4).

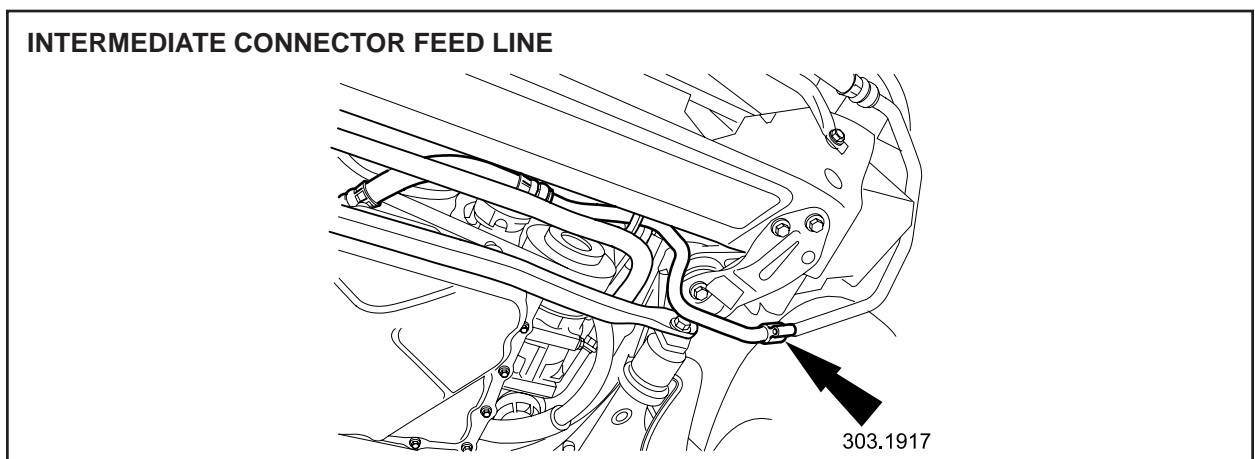

IILUSTRATION 4

21. Undo and remove the oil cooler return pipe/hose to intermediate connector-securing bolt, (Illustration 5).

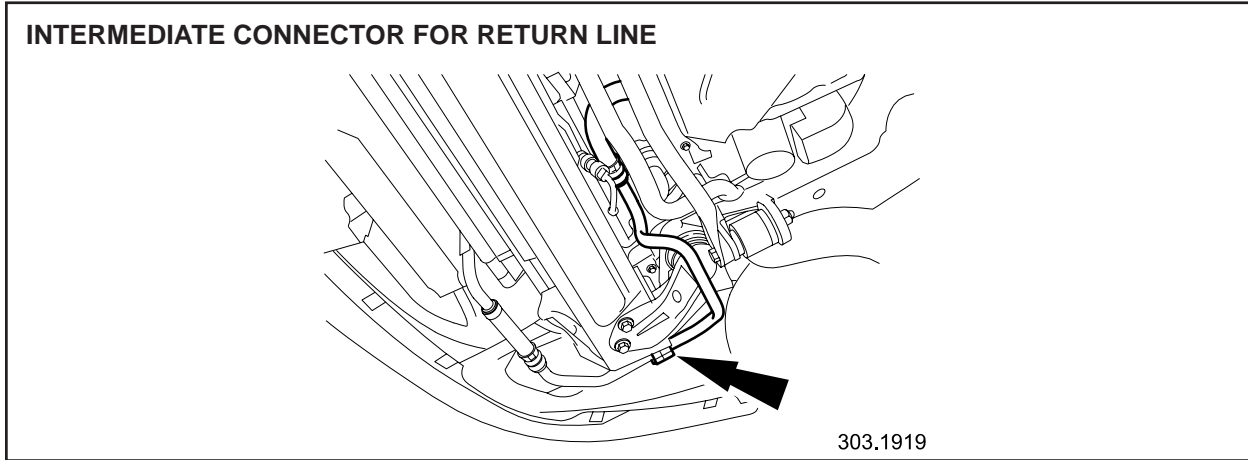

IILLUSTRATION 5

22. Disconnect and remove the oil cooler return pipe/hose from the intermediate connector.
23. Displace and discard oil cooler pipe O-ring seal.
24. Install suitable blanking plugs to cooler pipe/hoses.
25. Place the new oil cooler return pipe/hose to the front.
26. Displace and remove the blanking plugs from the cooler pipe/hose.
27. Install and fully seat the new O-ring seal to the cooler return pipe/hose.
28. Lubricate the new O-ring seal.
29. Reposition and align the oil cooler return pipe/hose to the intermediate connector and reconnect.
30. Install and tighten intermediate connector securing bolt (Illustration 6).

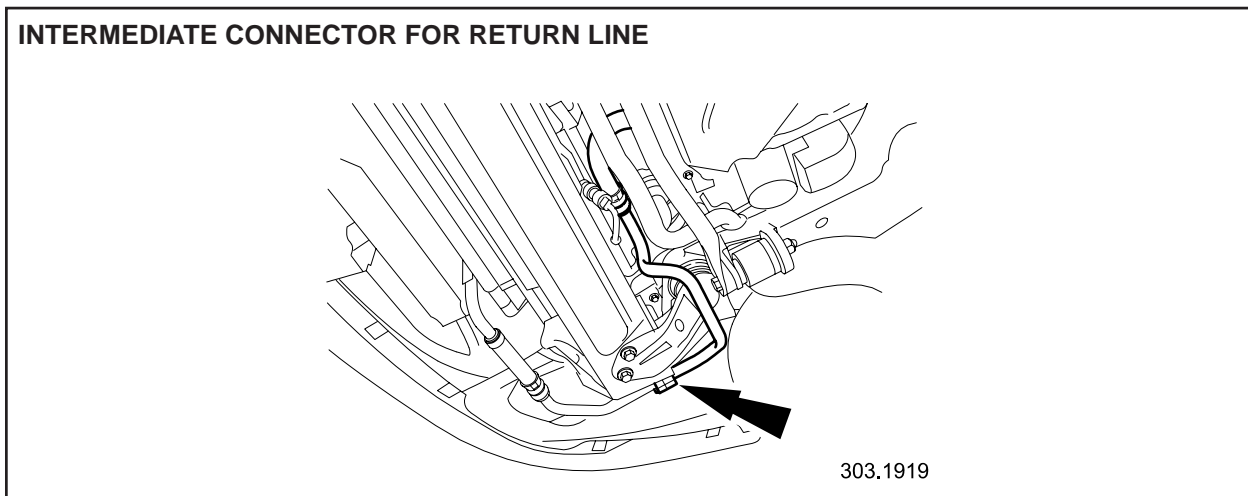

IILLUSTRATION 6

31. Lubricate the oil cooler feed and return pipe/hoses O-ring seals.
32. Reposition and align the oil cooler feed and return pipe/hoses to the engine port.
33. Reconnect the oil cooler feed pipe/hoses to the engine port.
34. Reposition and install the oil cooler pipe/hose retaining plate.
35. Install and tighten the retaining plate securing bolt.
36. Clean spillage from the front of the engine.
37. Remove the drain tray from under the vehicle.
38. Reinstall the undertray.
39. Lower the vehicle.
40. Start and run the engine until the oil pressure rises.
41. Turn off the engine.
42. Check, and if necessary, top up the engine oil.
43. Remove the exterior vehicle protection and close hood and door.

Global Technical Reference (GTR) Workshop Manual Information:

Dealer access: <https://hub.franchise.jaguar.com>

Internet access: <http://www.jaguartechno.com>

Parts Information:

<u>DESCRIPTION</u>	<u>PART NUMBER</u>	<u>QTY</u>
Oil cooler feed pipe/hose (includes O-ring)	C2N 2208	1
Oil cooler return pipe/hose (includes O-ring)	MJE 7461AB	1
O-Ring	KSR 609001	2

Warranty Information:

Warranty claims should be submitted quoting program code S846 together with the appropriate option code from the table below. This will result in payment of the stated time and where applicable parts/miscellaneous expense codes.

The options that allow for drive in/drive out can only be claimed if the vehicle has been brought into the workshop for this action alone to be undertaken.

The SROs, parts and miscellaneous items have been included for information only; there will be no requirement to enter the parts, SROs and miscellaneous items onto the claim.

Service Action S846

Model	Year	VIN Range
XK8	2004 MY	42 A39699 - 42 A40264
XKR	2004 MY	43 A39699 - 43 A40264
XK8	2005 MY	52 A40265 - 52 A41740
XKR	2005 MY	53 A40265 - 53 A41740

Program Code	Option	Description	SRO	Time	Part Number	Part Description	Qty
S846	A	Check date code - no further action required	10.10.99	0.2 hrs.	-	-	-
S846	K	Check date code – no further action required	10.10.99	0.2 hrs.	-	-	-
		Drive in/drive out	10.10.10	0.1 hrs.			
S846	B	Check date code and replace feed and return pipe/hoses	12.92.14	0.7 hrs.	C2N 2208	Oil cooler feed pipe/hose	1
					MJE 7461AB	Oil cooler return pipe/hose	1
					KSR 609001 ZZZ001	O-Ring Top up oil	2 \$5.00
S846	C	Check date code and replace feed and return pipe/hoses	12.92.14	0.7 hrs.	C2N 2208	Oil cooler feed pipe/hose	1
					MJE 7461AB	Oil cooler return pipe/hose	1
					KSR 609001 ZZZ001	O-Ring Top up oil	2 \$5.00
		Drive in/drive out	10.10.10	0.1 hrs.			

Note: Always perform a DDW claim search first to determine whether this service action has been performed on this vehicle. The “Review Claim History” function will provide a listing of all claims against the vehicle. If this service action number appears in the program code field, do not perform this service action.



October 2004

JAGUAR CARS

555 MacARTHUR BOULEVARD

MAHWAH NJ 07430

T 800 4 JAGUAR

www.jaguar.com

RE: S846 Service Action - Oil Cooler Feed Pipe Failure

Dear Jaguar Owner

Jaguar Cars has identified a concern relating to the possibility of the oil cooler feed pipe hose failing. If you are a recipient of this notice, and an owner of one of the vehicles within the VIN range, this letter is to inform you that your vehicle is included in this service action.

The following is a breakdown of the affected vehicles by model and (VIN) range.

➤ 2004 Jaguar XK/XKR A39699 - A41740

What is the concern?

The oil cooler feed pipe hose may fail at the outer crimp of the oil cooler feed pipe/hose, resulting in the possibility of engine oil loss and reduced engine performance.

What will Jaguar and your Jaguar Dealer do?

An authorized Jaguar Dealer will inspect the oil cooler feed pipe/hose for a date code. If the date code is within the effected range the engine oil cooler feed pipe/hose will be replaced.

What should you do?

At your earliest convenience you should contact your authorized Jaguar Dealer who will be able to make an appointment to undertake the necessary actions. To assist your Dealer, please ensure that at the time of contact you have at hand your applicable Vehicle Identification Number.

How long will it take?

The time to complete the repair on your vehicle is approximately one hour. However due to vehicle scheduling your Dealer may need to keep your vehicle longer to complete the repair.

Moved or no longer own a Jaguar?

Please fill out the enclosed card and return it to Jaguar by simply putting it in the mail.

Attention Leasing Agencies

Please forward this Service Action notice to the lessee within 10 days.

What should you do if you have further questions?

Please contact your Jaguar Dealer or the Jaguar Customer Relationship Center at 1 800 4JAGUAR (1-800-452-4827), option 9 or by e-mail at jaguarowner@jaguar.com. Should you have the need to contact Jaguar by mail, please address the correspondence to the Jaguar Customer Relationship Center using the above address.

Sincerely yours,

Benjamin I. Weiner
Customer Satisfaction Manager