

2002 XK RANGE - Front Disc Brake - 206-03

Brake Disc Vehicles With: Brembo Brakes 70.10.10

Removal

1.  **WARNING:**
BRAKE DISCS MUST ALWAYS BE REPLACED IN PAIRS.

 **WARNING:**
BRAKE DUST, IF INHALED CAN DAMAGE YOUR HEALTH. ALWAYS REMOVE BRAKE DUST USING A VACUUM BRUSH. DO NOT USE A COMPRESSED-AIR LINE TO DISPERSE BRAKE DUST INTO THE ATMOSPHERE.

 **CAUTION:**
Replacement of nuts and bolts: Various thread-locking devices are used on nuts and bolts throughout the vehicle. These devices restrict the number of times a nut or bolt can be used. See section <<100-00>> for information.

 **CAUTION:**
The Brembo caliper is aligned to the brake disc when it is first installed to the vehicle, therefore, care must be taken not to disturb this alignment. When removing the caliper; remove the bolts that secure the anchor bracket to the vertical link only. DO NOT loosen any other caliper bolts.

 **CAUTION:**
The front brake discs are directional and must be installed to the correct side of the vehicle. Refer to Description and Operation, section <<206-03>> for further information.

 **CAUTION:**
Do not loosen bolts securing brake disc to disc mounting.

Open engine compartment and install paint work protection covers to fenders.

2. Raise front of vehicle and support on stands. See Section <<100-02>>.

3. Remove front wheels. Refer to operation <<74.20.05>>.

2002 XK RANGE - Front Disc Brake - 206-03

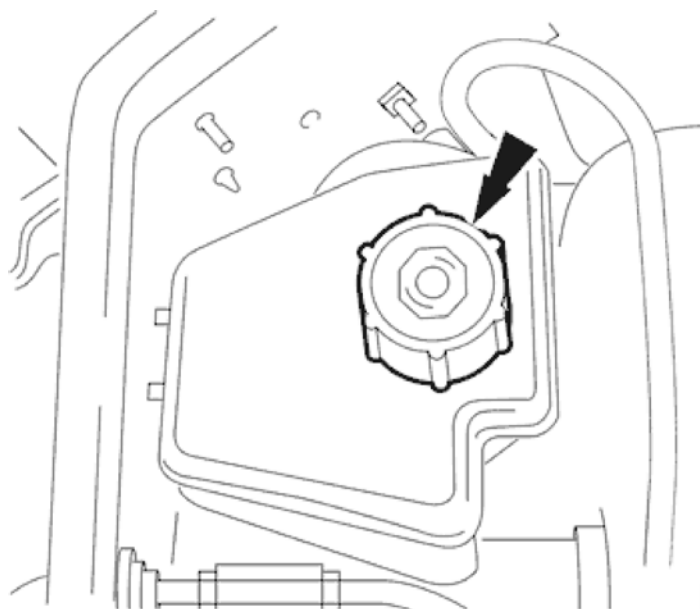

E35168

4.  **CAUTION:**
Remove brake fluid spillage immediately from paint work, with clean water.

Loosen brake fluid reservoir-cap.

- Position a cloth around the reservoir to collect any fluid spillage.

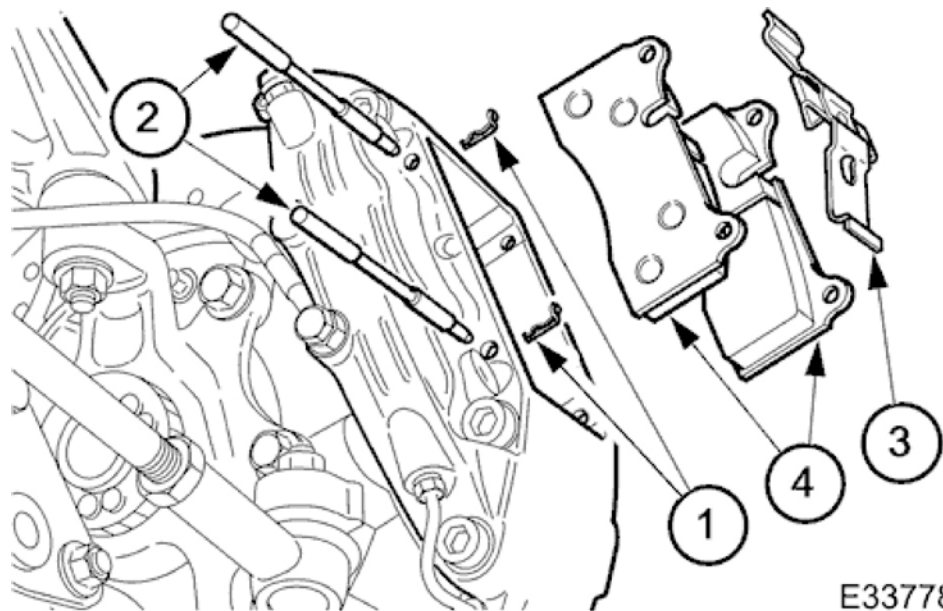

E33778

5.  **CAUTION:**
Always install new brake pads, irrespective of the condition of the original pads, when renewing brake discs.

Remove brake pads from caliper.

1. Remove 'R' clips.

2002 XK RANGE - Front Disc Brake - 206-03

2. Withdraw pins from caliper.
3. Remove anti-rattle spring.
4. Discard brake pads.

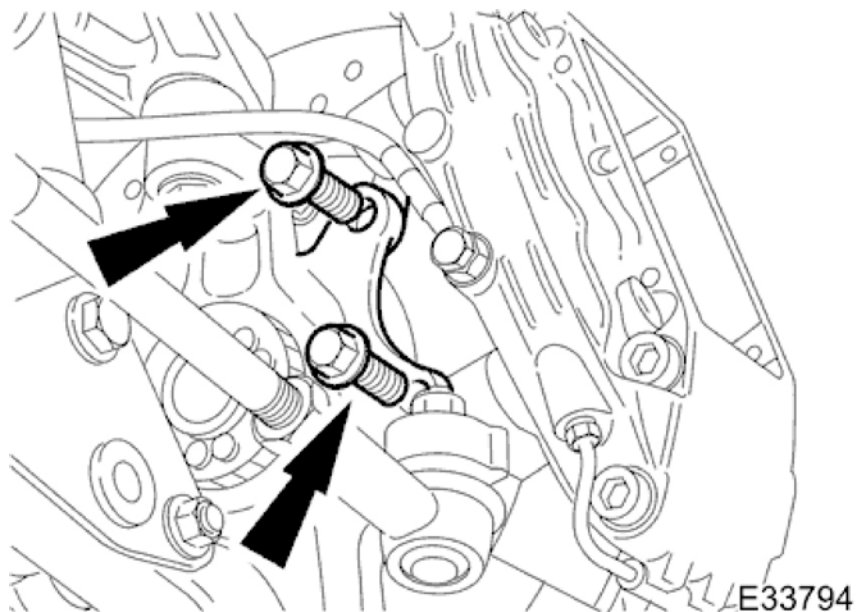

6.  **CAUTION:**
Only remove the bolts securing the caliper anchor bracket to the vertical link. Refer to caution above for more information.

 **CAUTION:**
Do not allow the caliper to hang on the hydraulic hose, as this will damage the hose.

Remove caliper from vertical link.

- Remove bolts.
- Remove caliper and tie aside.

2002 XK RANGE - Front Disc Brake - 206-03

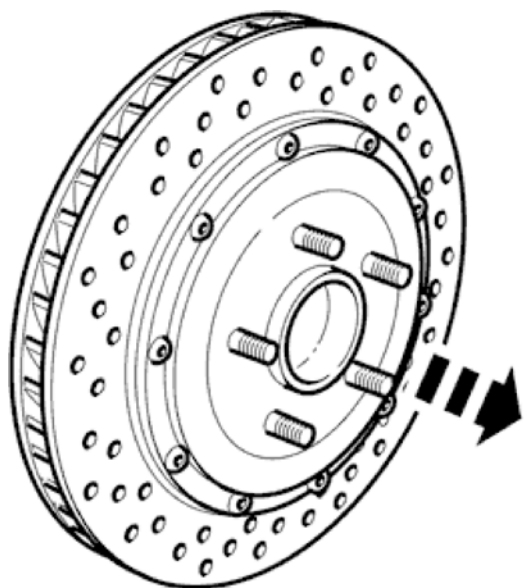

E33797

7. Remove brake disc from hub.
8. Repeat above procedure to remove opposite side brake disc.
9. Remove brake dust from calipers and clean mating surfaces, see WARNING above.

Installation

1. Thoroughly clean the mating surface areas of the hubs and brake discs.

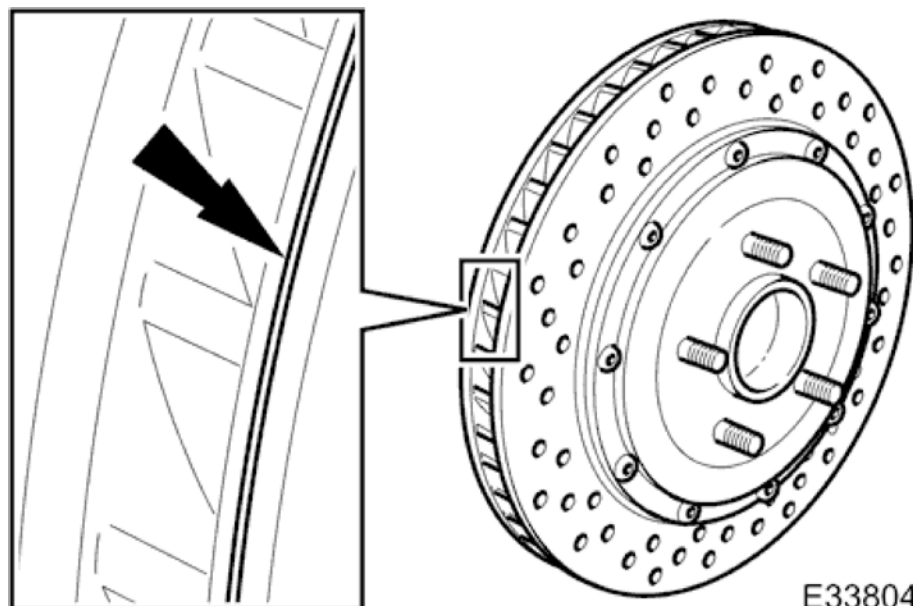

E33804

2.  CAUTION:

2002 XK RANGE - Front Disc Brake - 206-03

The front brake discs are directional and must be installed to the correct side of the vehicle.

Install brake disc to hub.

- The left-hand disc can be identified by a groove running around the circumference of the outer disc wall.

3. Check brake disc run-out. Refer to General Procedures section <<206-03>>.

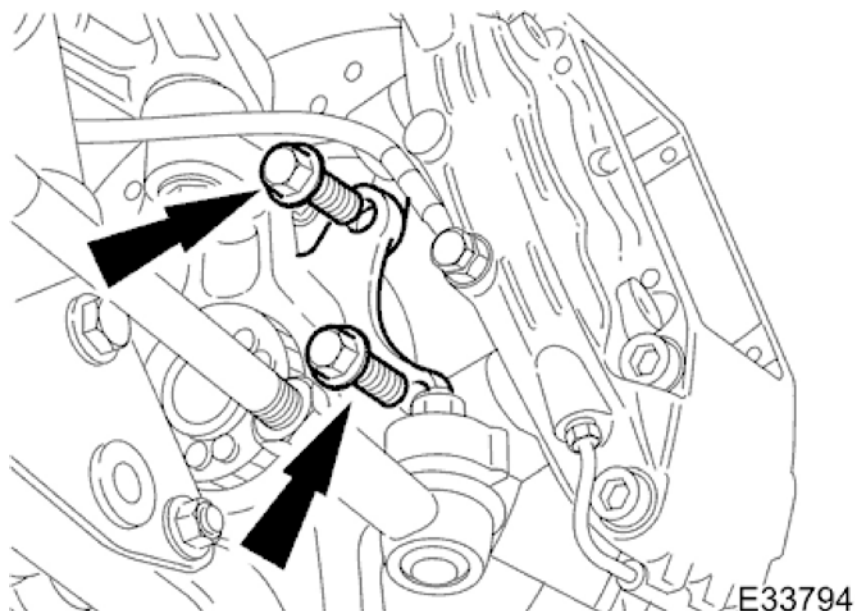

4. Install caliper to vertical link.

- Install and tighten bolts to 140 Nm.

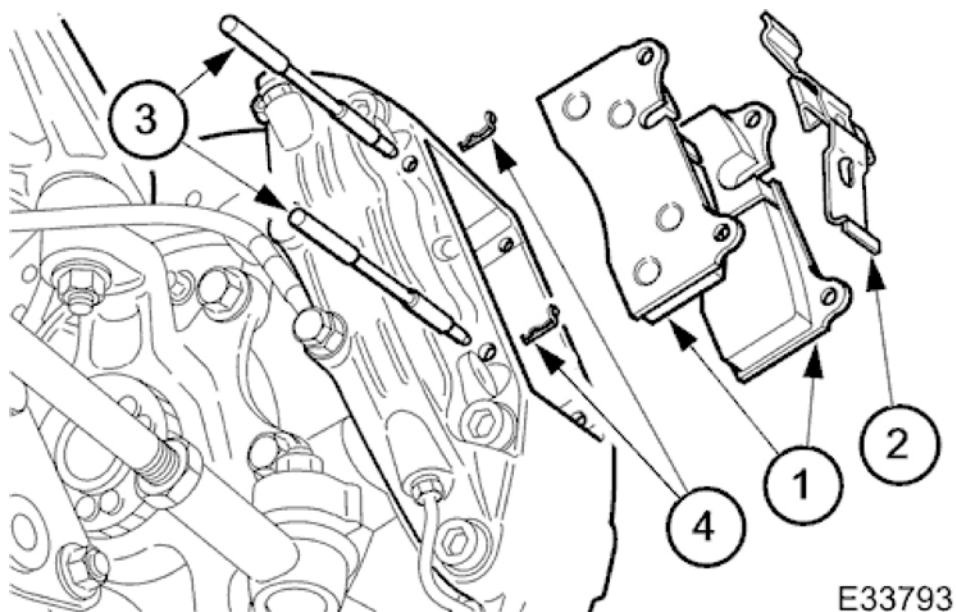

5.  **CAUTION:**

Always install new brake pads, irrespective of the condition of the original pads, when renewing brake discs.

2002 XK RANGE - Front Disc Brake - 206-03



CAUTION:

Retracting the caliper piston may cause the fluid reservoir to over-flow. Remove brake fluid spillage immediately from paint work, with clean water.



CAUTION:

Note the condition of pins and 'R' clips and replace if necessary.

Install brake pads into caliper housing.

- Slowly retract caliper pistons.
 1. Install pads.
 2. Position anti-rattle spring.
 3. Install pins.
 4. Install 'R' clips.

6. Repeat above procedure to install opposite side brake disc.

7. Fit wheels. Refer to operation <<74.20.05>>.

8. Remove stands and lower vehicle. Refer to section <<100-02>>.

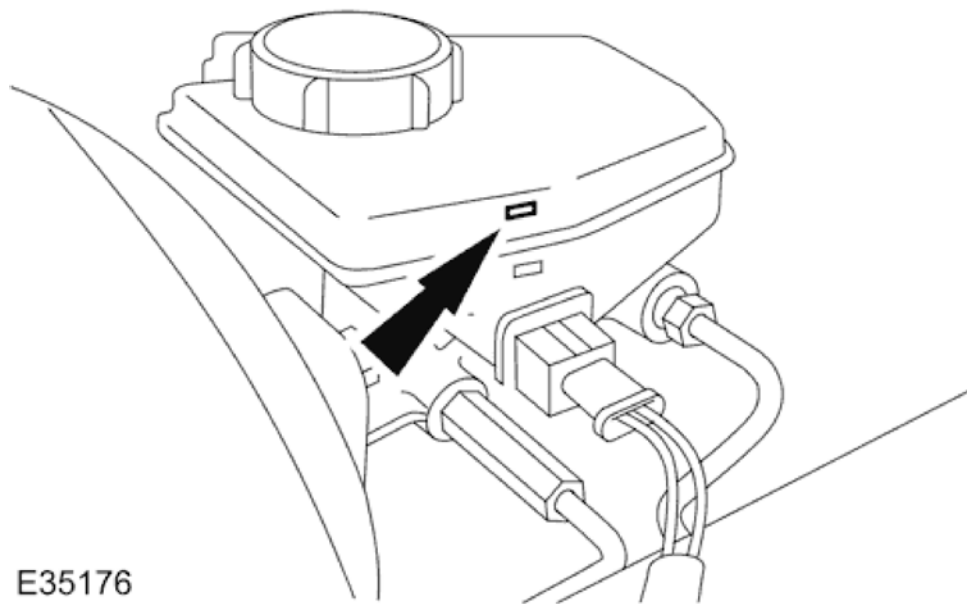

E35176



9. CAUTION:

Remove brake fluid spillage immediately from paint work, with clean water.

Check brake fluid level.

- Check brake fluid level is at the maximum mark.
- Remove cloth.
- Fit cap.

2002 XK RANGE - Front Disc Brake - 206-03

10. Remove paint work protection covers, and close engine compartment.
11. Start the engine and repeatedly press the brake pedal until brake pressure is evident.