

Damaged Cupholder –
Replace Mechanism Only –
Repair Procedure

MODEL
1997 MY-ON XK8 Range
1998 MY-ON V8 XJ Series
VIN
001001-ON
812256-ON

Remove and destroy Bulletin 501-38, dated 12/99.
Replace with this Bulletin.
Revisions are marked with a bar and in **bold text**.

Issue:

Repairing the cup-holder mechanism, which in the past required installing a new console lid assembly, can now be done by installing a replacement mechanism in the existing lid assembly. The availability of the cup-holder mechanism, as a separate replacement part, allows a more cost effective repair of the lid assembly.

Action:

In case of a customer complaint of a broken cup-holder assembly, (shown in Illustration 1), remove the holder and install a new assembly in the cubby box lid as described on the next page.

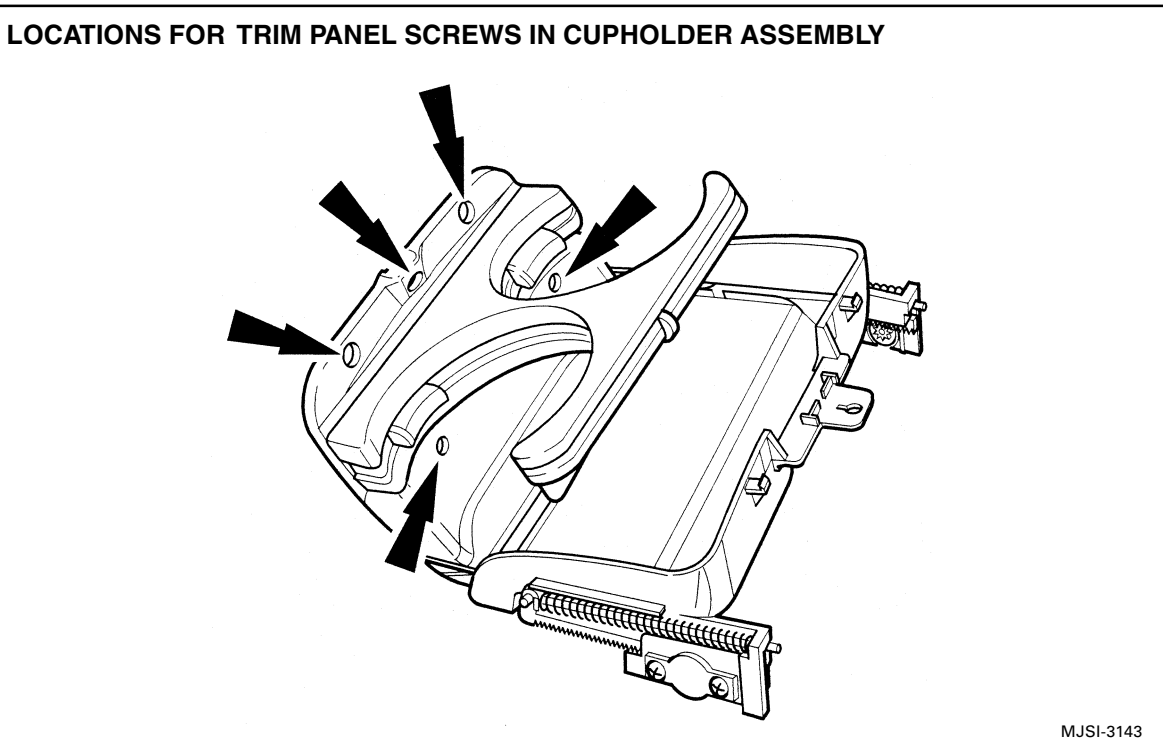

ILLUSTRATION 1

CONSOLE LID RETAINING SCREWS

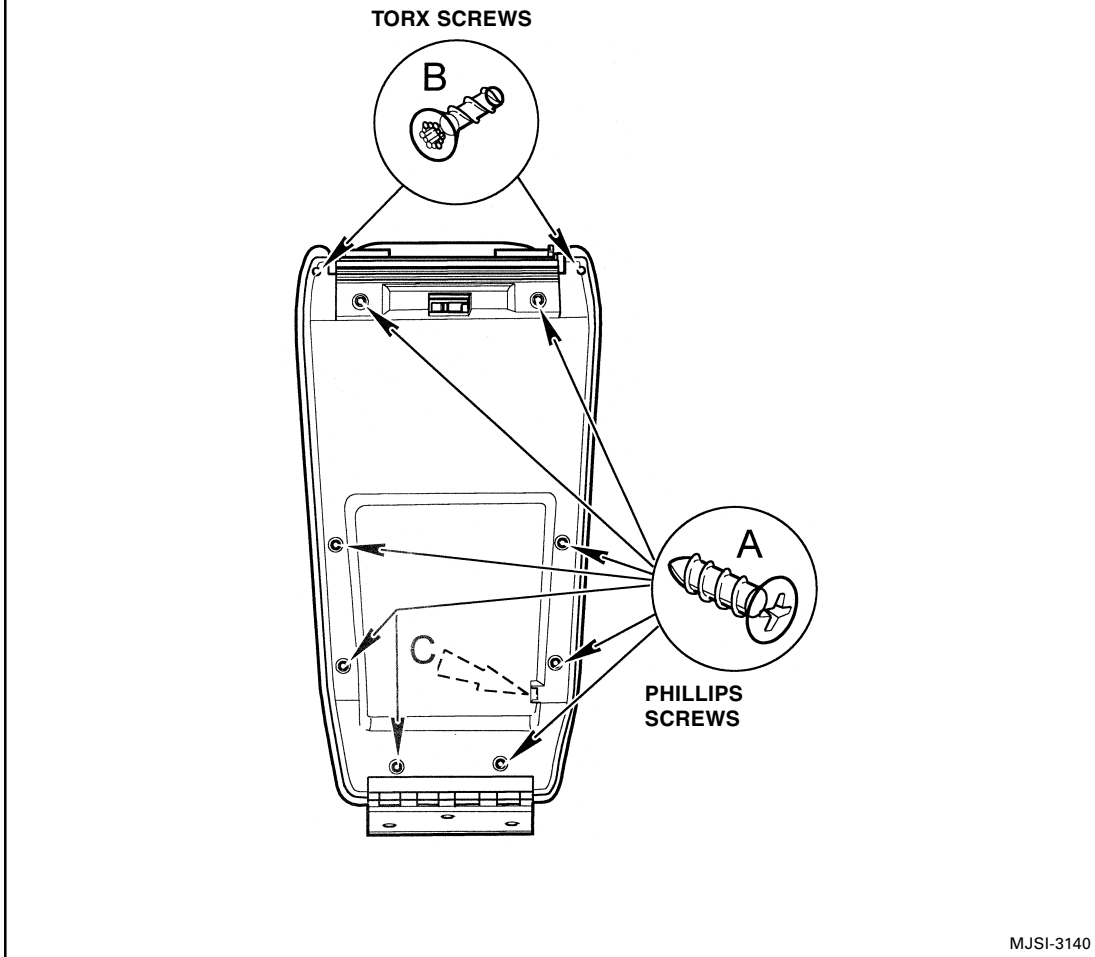

ILLUSTRATION 2

REPLACING CUPHOLDER MECHANISM

1. Open the Console Lid and remove the screw, (C, illustration 2), that secures the check arm to the lid.
2. Remove the three screws that retain the lid and hinge to the console. Remove the lid from the console. Place the lid assembly on a clean bench area.
3. Remove the eight phillips-head screws, (A, Illustration 2), and the two T8 Torx head screws, (B, Illustration 2), that hold the inner finisher to the console lid. Remove the finisher and the hinge from the lid.

RETAINING SCREWS AND SPRING

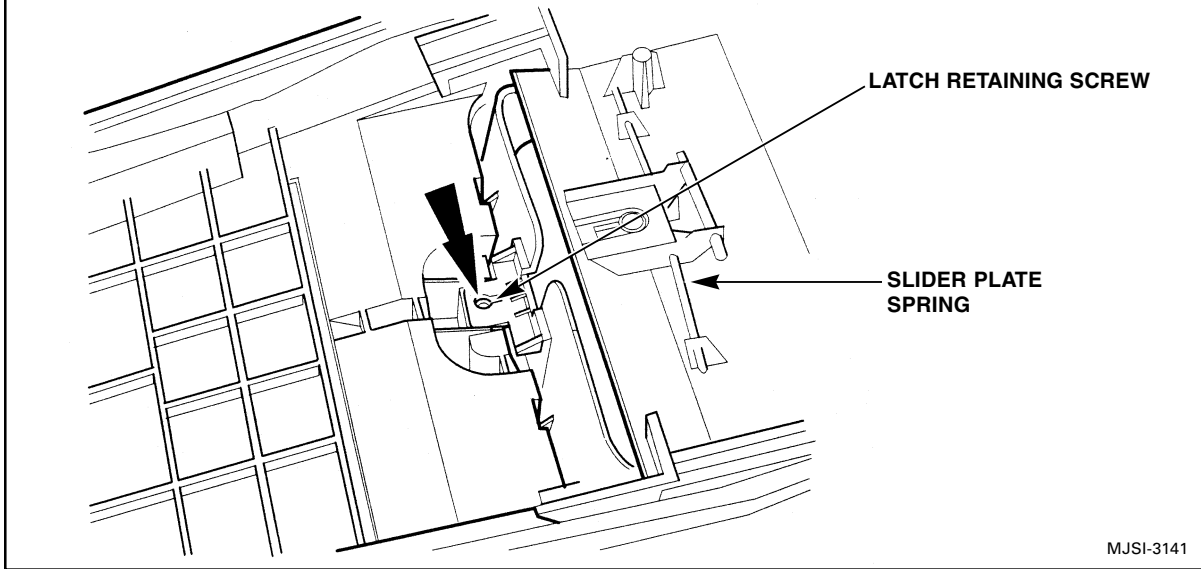

ILLUSTRATION 3

4. Remove the cup holder latch retaining screw, (Illustration 3).
5. Remove the latch and the cup-holder mechanism with its trim panel from the lid.
6. Remove the five No. T8 Torx head screws, (arrowed in Illustration 1), that retain the trim panel. Remove the panel from the mechanism.

Note: The trim panel is released by pulling the bottom edge out a little and then pushing upwards, to disengage the hooked projection on the rear of the trim pad from the mechanism.

7. Discard the damaged mechanism.

CUPHOLDER MECHANISM AND TRIM PANEL

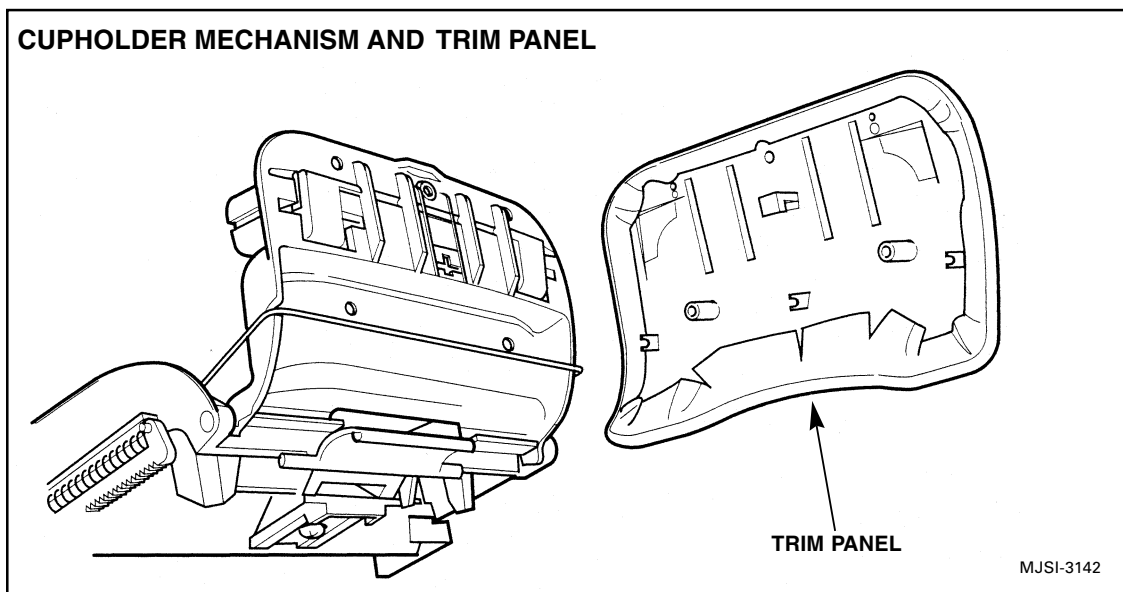

ILLUSTRATION 4

ASSEMBLY

Installation of a new Console Lid Assembly is a reversal of the removal procedure.

Note the following points:

- Always refer to the recommended torque settings when assembling the mechanism.
- Ensure that the damper wire, which acts as a check-arm, and the hooked projection, which locates the trim pad to the mechanism, are correctly engaged when the trim panel is installed on the mechanism.
- Check that the slider-plate spring, (Illustration 3), is present and in the correct position and that the latch paddle functions correctly i.e. it must fully latch to the console.
- Ensure that the lock screw, (C, Illustration 2), is present and correctly aligned in the substrate before assembling the lid.

TORQUE SETTINGS

Description	Number	Torque	
Liner screw	6	13 +/- 2 Nm	115.1 +/- 17 lb in
Small Torx head screw	2	5 +/- 2 Nm	44.3 +/- 17 lb in
Latch screw	1	9 +/- 2 Nm	79.7 +/- 17 lb in

PARTS INFORMATION:

<u>DESCRIPTION</u>	<u>PART NUMBER</u>	<u>QTY</u>
Cup-holder assembly - 1997-99 MY	GNA 7692AB	1
Cup-holder assembly - 2000 MY-ON	GNF 7692AA	1

WARRANTY INFORMATION:

Claims for replacement of the entire console lid when only the cupholder is defective will be charged back.

WARRANTY INFORMATION:

<u>FAULT CODE</u>	<u>R.O. NUMBER</u>	<u>DESCRIPTION</u>	<u>TIME ALLOWANCE</u>
UP FD 01	76.25.27	Cupholder assembly - replace	0.45 hrs.