

Air Conditioning

Introduction

Component Location

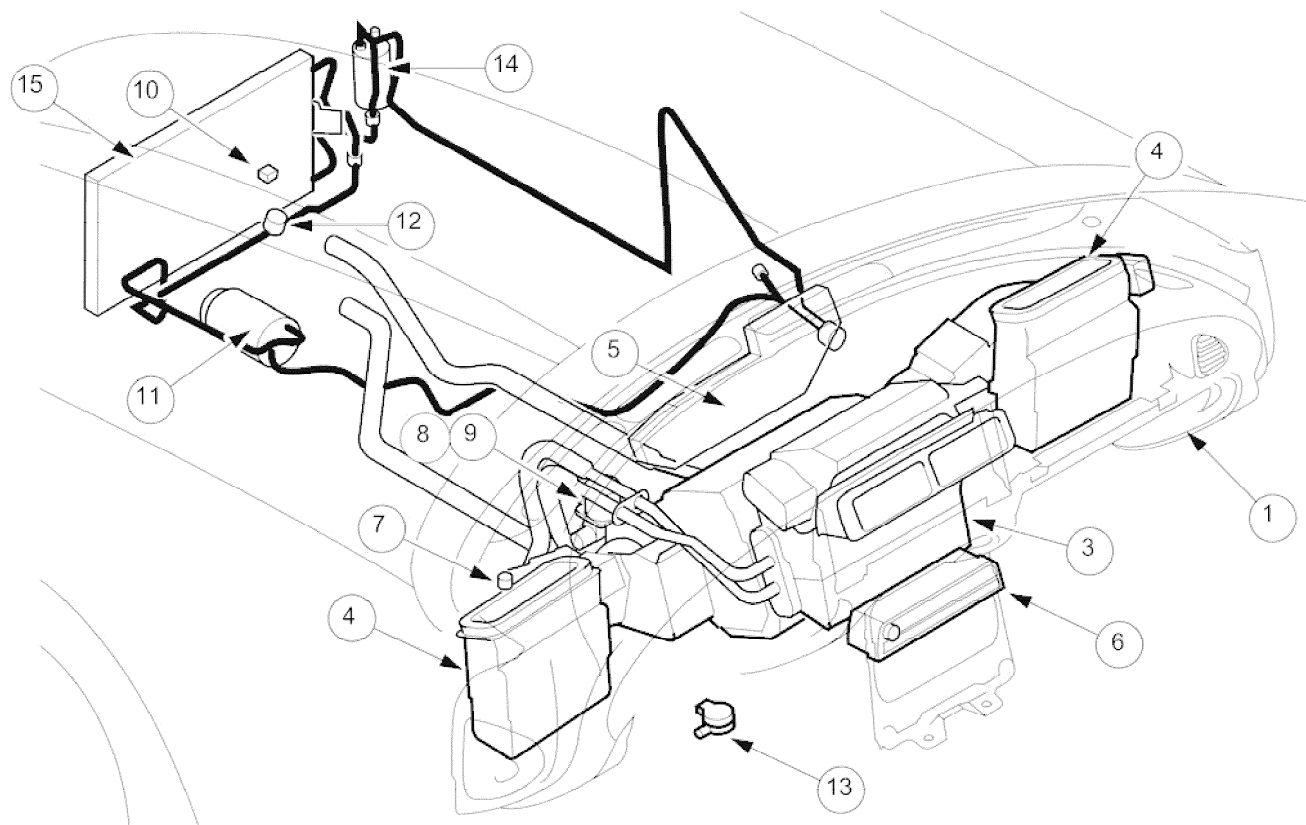

E34299

Parts List

Item	Description
1	Fascia panel with integral ducting
2	Heater / cooler assembly
3	A/CCM
4	Blower LH and RH
5	Plenum
6	Control panel
7	Solar sensor (LHD shown)
8	Assembly valve - water
9	Assembly pump - water
10	Temperature sensor - external
11	Compressor
12	Pressure switch - 4 level
13	Motorized in-car aspirator (LHD shown)
14	Receiver drier
15	Condenser

The climate control system features fully automatic control of temperature, blower speed (airflow) and air distribution to maintain optimum comfort under most driving conditions.

Manual controls are provided to allow the operator to over-ride automatic operation.

2003 XK RANGE - Air Conditioning - 412-03

System Features

- Twin blower assemblies
- Center mounted evaporator, heater and air distribution unit
- Electric solenoid water valve controlled heating
- Electric water pump assembly
- Servo motor driven air distribution flaps
- Temperature differential control between foot and face outlets
- Dedicated side glass defrost / demist vents
- External temperature sensor
- Motorised in-car aspirator
- Solar sensor

Electronic Control Panel

- Liquid Crystal Display (LCD)
- Digital temperature display
- Manual fan speed level
- External temperature display
- Celsius / Fahrenheit selection
- Heated windshield switch (where fitted)
- Heated backlight switch
- Defrost switch
- Manual airflow distribution overrides (4)
- Access to self diagnostic system and error codes

Sensors

- External ambient temperature sensor
- Motorized in-car aspirator
- Heater matrix temperature sensor
- Evaporator temperature sensor
- Solar sensor

These sensors feedback information to the Air Conditioning Control Module (A/CCM) which automatically adjusts air temperature, airflow volume and distribution from the air conditioning unit to maintain a stable passenger compartment average temperature under changing weather conditions.

Major Components

2003 XK RANGE - Air Conditioning - 412-03

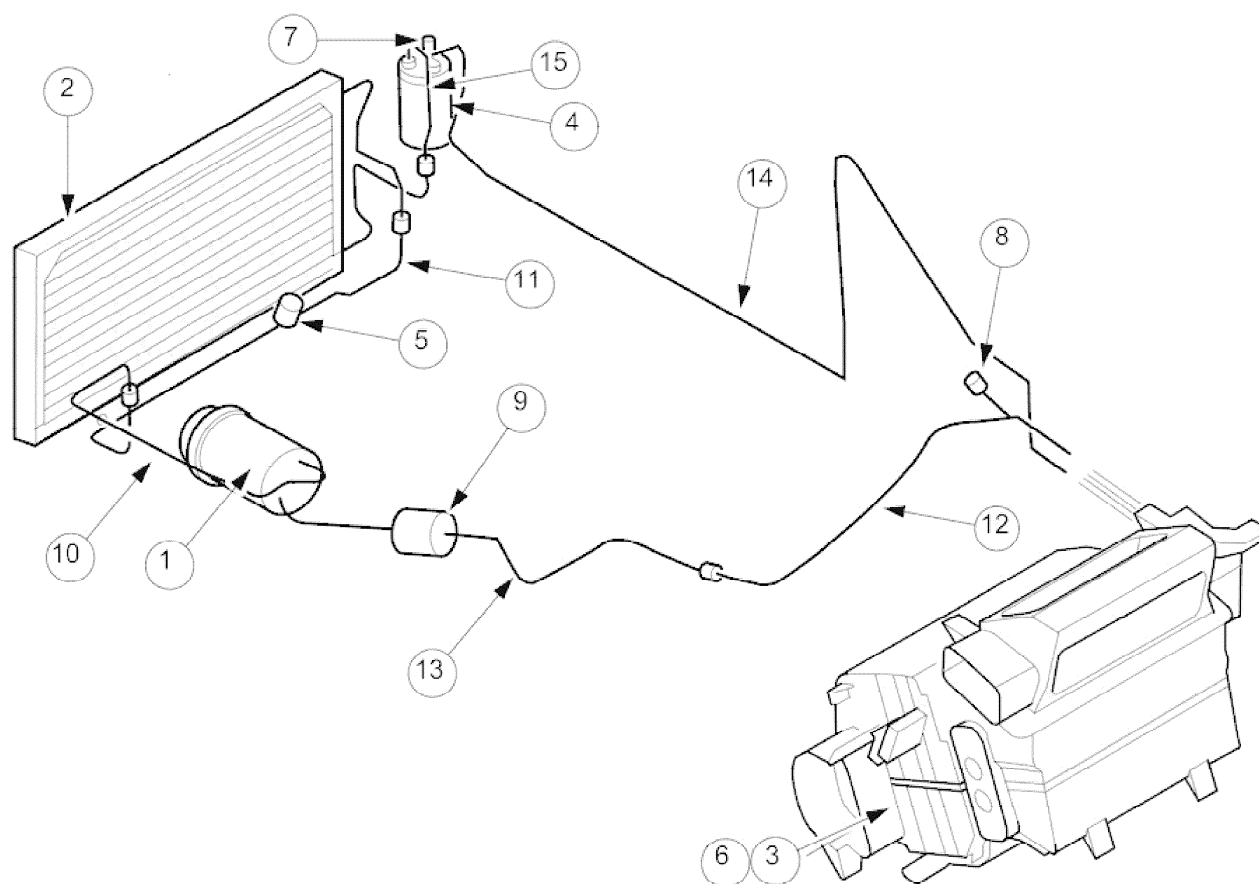

E34300

Item	Description
1	Compressor assembly
2	Condenser
3	Evaporator and heater matrix (internal)
4	Receiver drier
5	4-level pressure switch
6	Expansion valve (internal)
7	High-side charge port
8	Low-side charge port
9	Suction muffer
10	Discharge hose
11	Discharge pipe
12	Suction hose
13	Suction pipe
14	Liquid line
15	Jumper hose (condenser hose)

Compressor

Features

- Engine mounted, driven by the accessory drive belt.
- Fixed displacement type.
- High-pressure relief valve, to avoid system over-pressure.
- ECM controlled clutch energized via a relay.

Receiver drier

2003 XK RANGE - Air Conditioning - 412-03

- Vertically mounted on the right-hand side of the engine compartment next to the engine coolant radiator.
- Fitted with the high-side charge port.

Condenser

- Multi-pass fin-over-tube type, mounted in front of the engine cooling pack and directly to the radiator.

Pressure (Bitron) switch

- Located in the discharge pipe.
- Provides a signal, via the A/CCM, to the ECM, to disengage the compressor clutch should the refrigerant pressure be < 2 bar or > 30 bar.
- Provides a hard-wired signal to the ECM, to switch the cooling fans to HIGH speed at 22 bar rising pressure and to LOW speed at 17,5 bar falling pressure.
- Provides a hard-wired signal to the ECM, to switch the radiator cooling fans to LOW speed at 12 bar rising pressure and to switch the fans OFF at 8 bar falling pressure.

Expansion Valve

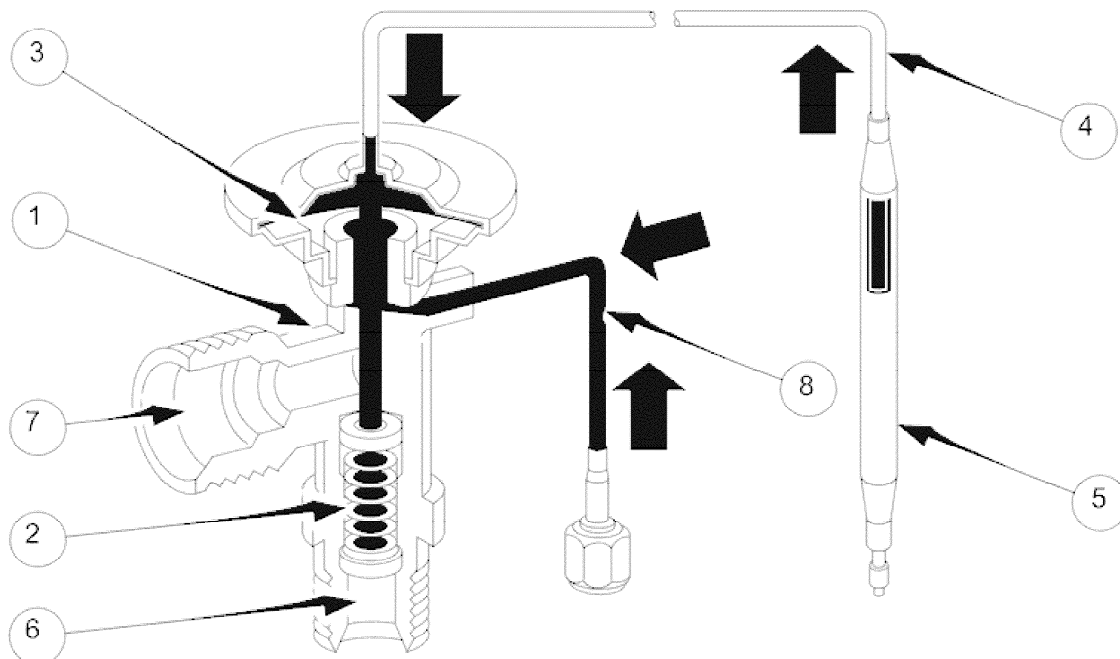

E35389

Parts List

Item	Description
1	Valve body
2	Pressure spring
3	Diaphragm
4	Capillary tube
5	Temperature sensing bulb
6	Valve inlet
7	Valve outlet
8	Equalizer pipe

The expansion valve is located inside the heater / air conditioning unit and comprises of a diaphragm, connected by a capillary tube to a temperature sensing bulb, which regulates the valve according to temperature variations at the evaporator outlet pipe. This component is NOT serviceable. See 'Refrigeration Cycle'

Air Conditioning (Heater / Cooler) Unit

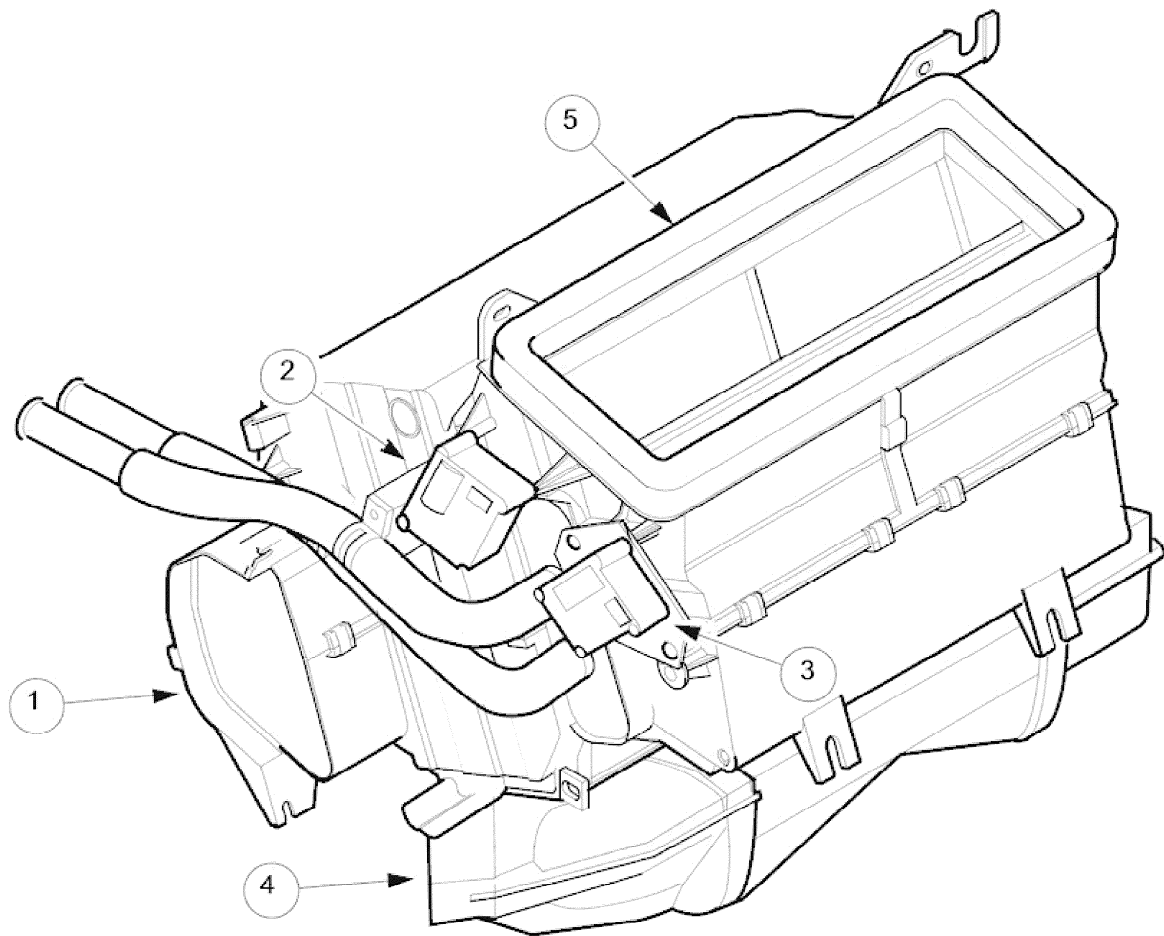

E34297

Parts List

Item	Description
1	Air inlet - LH (RH opposite, not shown)
2	Servomotor - cool air bypass
3	Servomotor - footwell outlet
4	Air outlet - footwell
5	Air outlet - ADB (with foam seal)

The air conditioning unit houses the evaporator, heater matrix and their temperature sensors. The unit also incorporates two servo motor operated air distribution flaps which regulate airflow to the front footwells and the quantity of airflow through the cool air bypass (air which by-passes heater matrix) up to the upper air distribution box (ADB).

When the front footwell flap is open, air is ducted to the footwell area via the lower air distribution duct (LADD) and front footwell duct. The LADD is clipped to the bottom of the air conditioning unit case and the front foot ducts clipped onto the outlets of the LADD.

Condensate (water) which forms on the evaporator fins is drained out of the unit case through two drains, located either side of the unit underneath the evaporator. The liquid is routed to the vehicle exterior via flexible tubes which are located behind the firewall heatshield.

Refrigeration Cycle

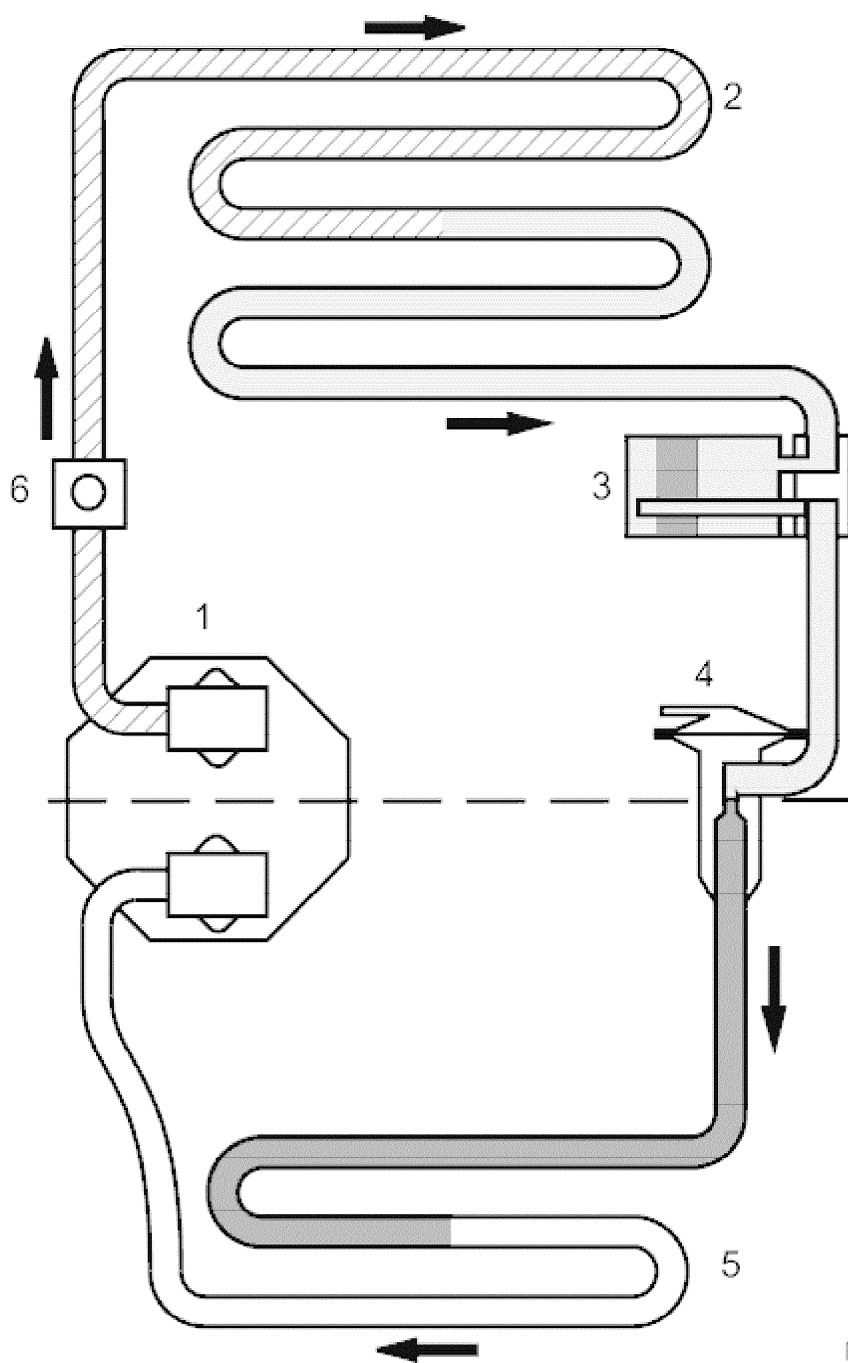

E35380

Item	Description
1	Compressor
2	Condenser
3	Receiver drier
4	Expansion valve
5	Evaporator
6	4-level pressure switch

The Compressor draws low pressure, low temperature, refrigerant from the evaporator and, by compression, raises the refrigerant temperature and pressure. High pressure, hot, vaporized refrigerant enters the condenser, where it is cooled by the flow of ambient air. A change of state occurs as the refrigerant cools in the condenser and it becomes a reduced temperature, high pressure, liquid.

From the condenser, the liquid passes into the receiver drier which has three functions:

2003 XK RANGE - Air Conditioning - 412-03

- Storage vessel for varying system refrigerant demand.
- Filter to remove system contaminants.
- Moisture removal via the dessicant.

With the passage through the receiver drier completed, the liquid refrigerant, still at high pressure, enters the expansion valve where it is metered through a controlled orifice, which has the effect of reducing the pressure and temperature. The refrigerant, now in a cold atomized state, flows into the evaporator and cools the air passing through the matrix.

As heat is absorbed by the refrigerant, it once again changes state, into a vapor, and returns to the compressor for the cycle to be repeated.

An automatic safety valve is incorporated in the compressor, which will operate if the system pressure rises above 41 bar. The valve will reseal when the pressure drops below 27,6 bar.

The terms 'high' and 'low' pressure (or side) refer to the pressure differential between the compressor and expansion valve ports. This differential is critical to system fault diagnosis and efficiency checks.