

Rear Quarter Window Regulator Motor Vehicles With: Convertible Top 86.25.11

Removal

1. Fully raise adjacent door glass and open door.
2. Remove convertible top. refer to <<76.86.15>>.
3. Remove rear quarter glass inner seal. Refer to <<76.40.33>>.

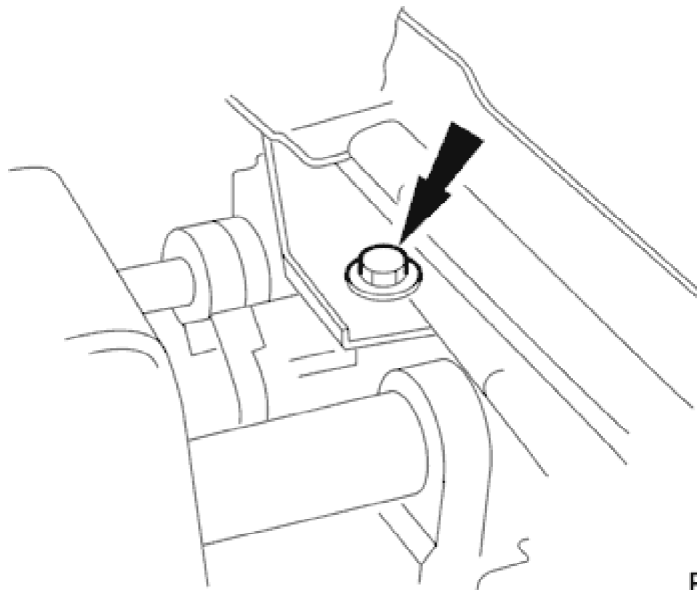

E35720

4. Remove inner seal carrier rear screw.

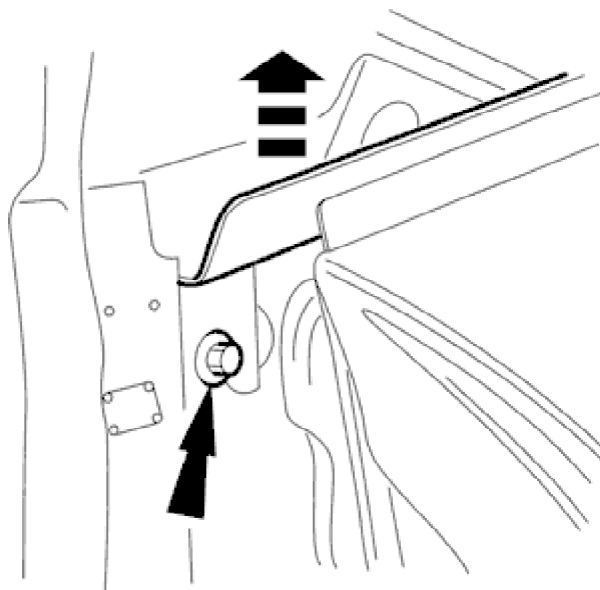

E36023

2001 XK RANGE - Glass, Frames and Mechanisms - 501-11

5. Remove seal carrier front screw and remove carrier from vehicle.

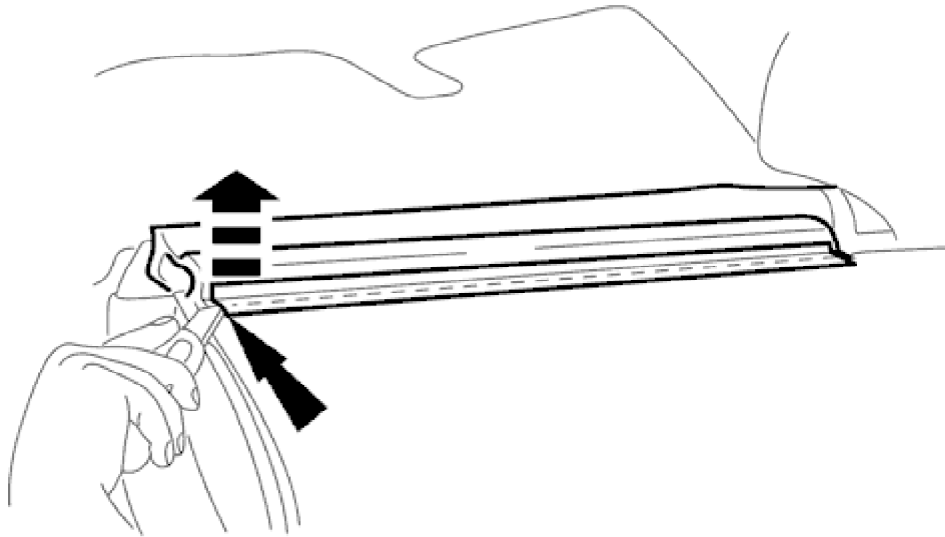

E36024

6. Remove quarter glass outer seal.

- Apply protective tape to rear fender along outer edge of seal.
- Exercising care to avoid damaging paintwork, use a thin blade over tape to remove seal from carrier.

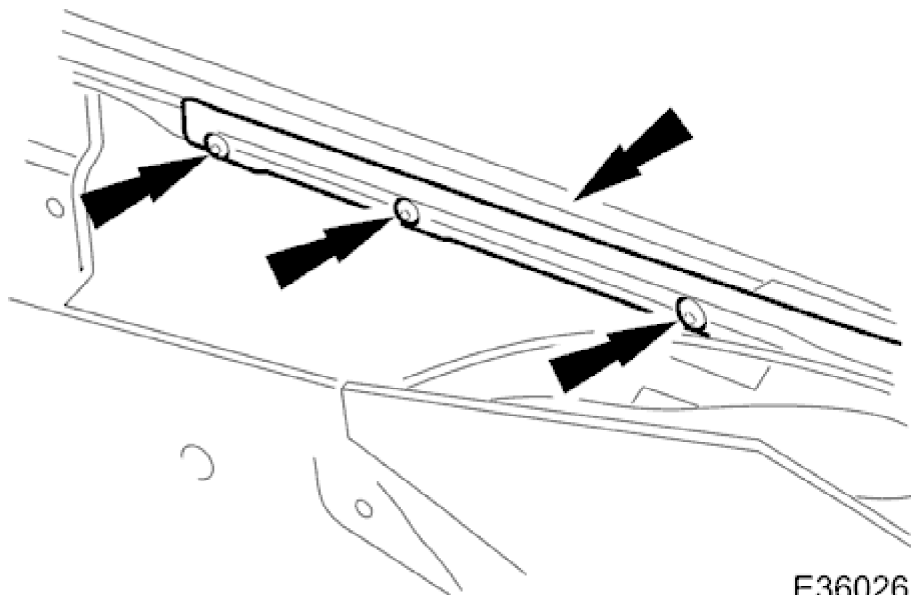

E36026

7. Remove quarter glass outer seal carrier.

- Remove screws.
- Remove seal carrier from vehicle.

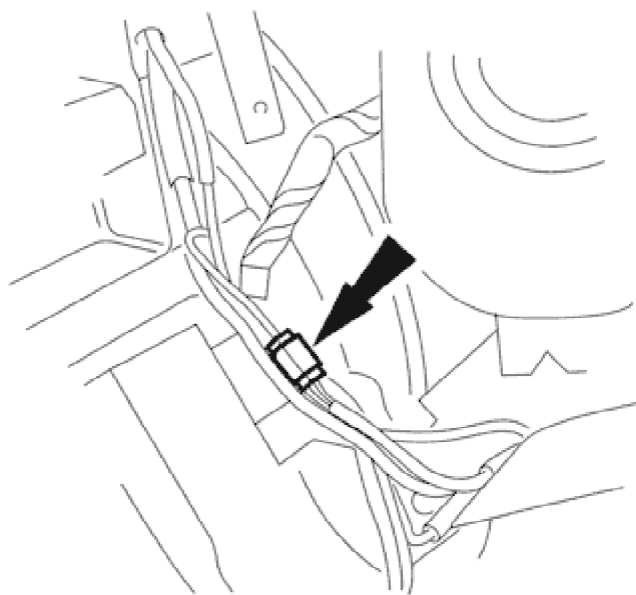

E35736

8. Disconnect lift motor link lead from rear harness multiplug.

9. If earlier PVC water shedder is installed, route glass lift motor link lead through penetration and remove water shedder from body.

10. Connect a switched 12 volt supply to motor link lead connector and power glass to fully raised position.

11. Switch off 12 volt supply and disconnect from motor connector.

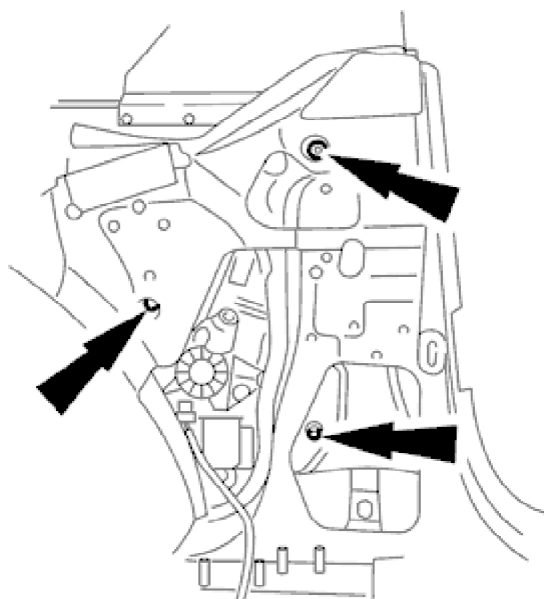

E35737

12. Remove three nuts securing glass lift motor/regulator assembly to body.

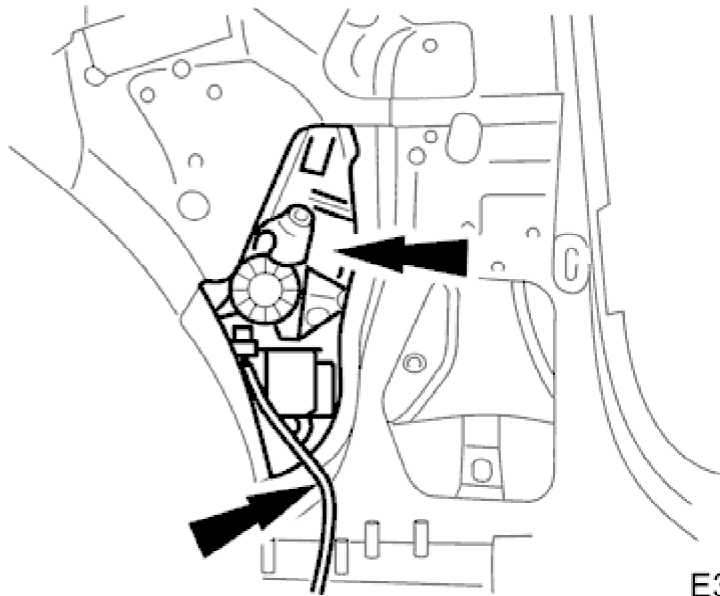

E35738

13. Feeding link lead and multiplug through water shedder (later moulded type), withdraw motor/regulator adjusters from body and remove assembly.

Installation

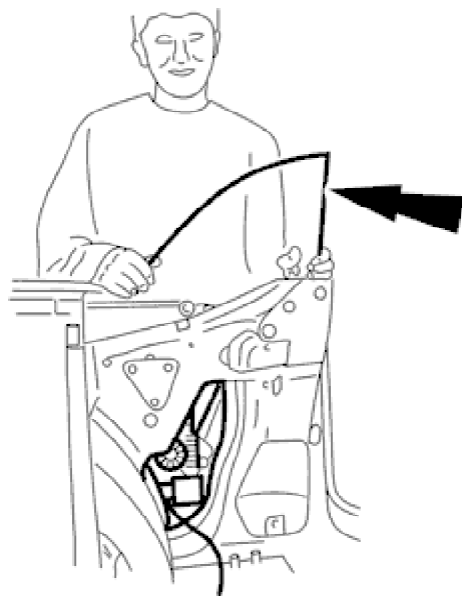

E35741

1. Guiding link lead through water shedder (later type), lower motor/regulator assembly through upper aperture and locate adjusters in body apertures.

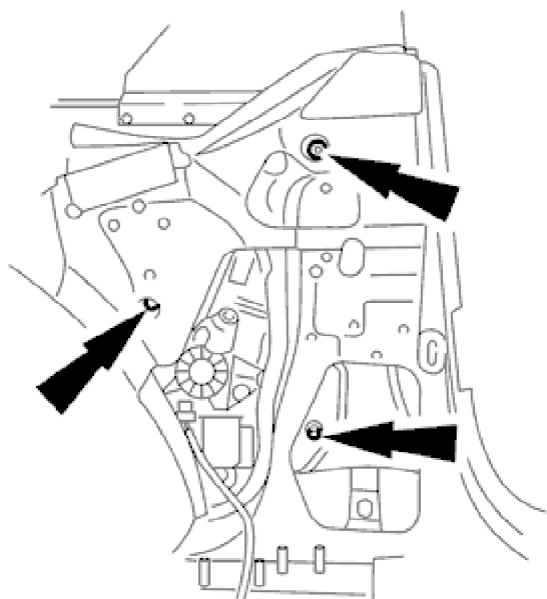

E35737

2. Install but do not fully tighten locking/securing nuts on motor/regulator adjusters.

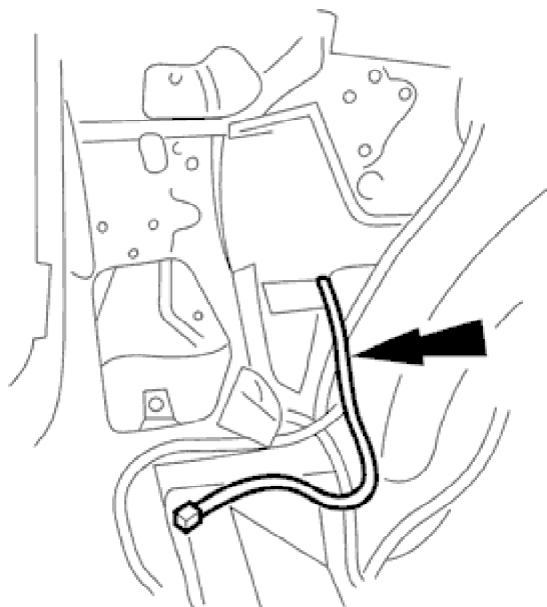

E35739

3. Install water shedder (early PVC type), routing motor link lead through penetration and leaving access for glass installation.

4. **NOTE:**

Do not install speakers, rear quarter casing or rear seat at this stage

Install and manually raise and latch convertible top assembly. Refer to <<76.86.15>>.

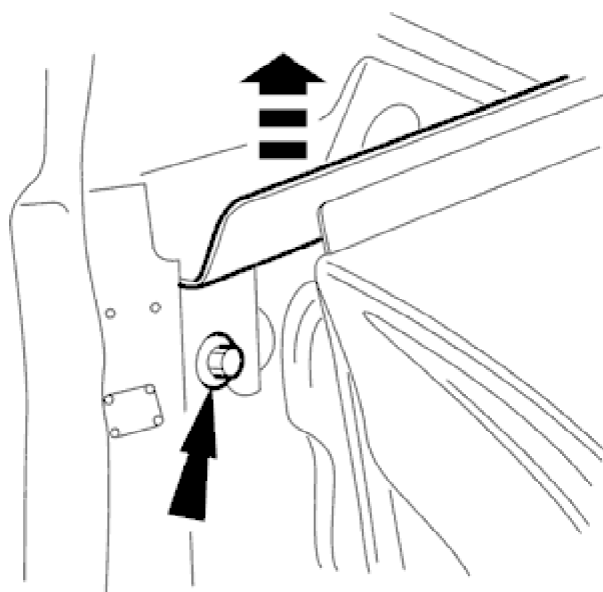

E36023

5. Position inner seal carrier on vehicle and install front screw.

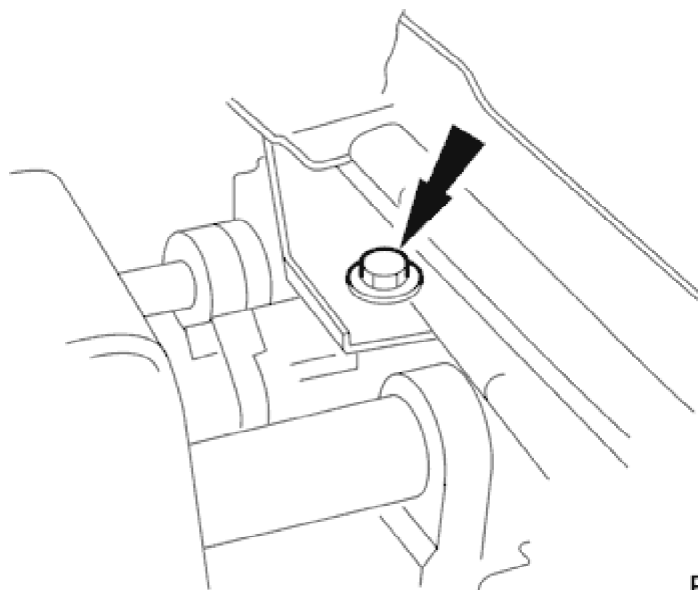

E35720

6. Install inner seal carrier rear screw.

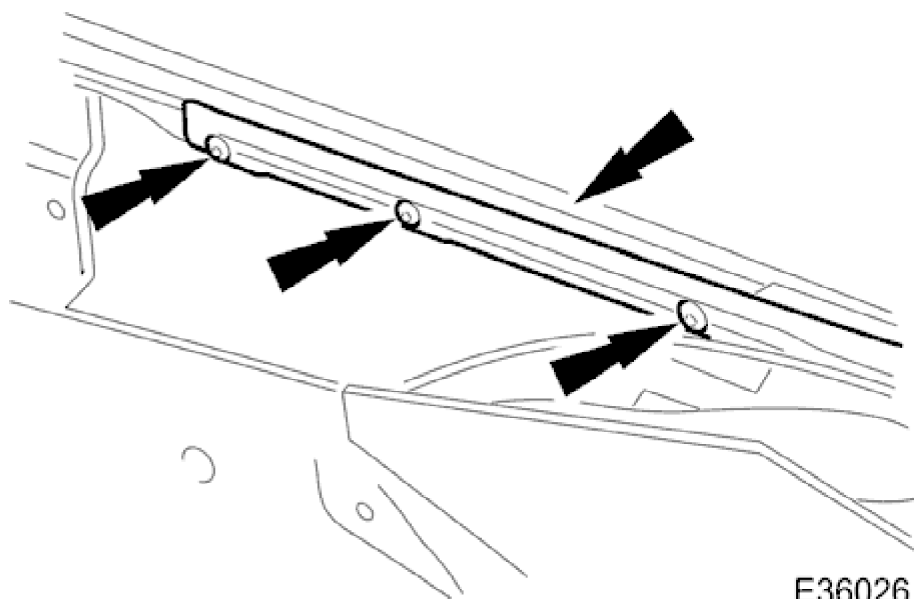

7. Install quarter glass outer seal carrier.

- Position seal carrier on vehicle.
- Install carrier screws.

8. Install rear quarter glass inner seal. Refer to <<76.40.33>>.

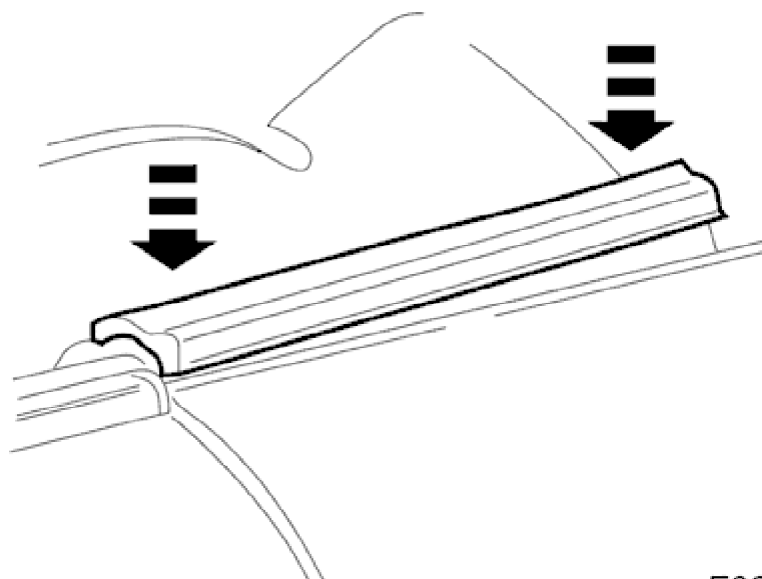

9. Install quarter glass outer seal.

- Exercising care to avoid damaging seal and paintwork, use a rubber faced hammer to install seal on carrier.
- Remove protective tape.

10. Connect switched 12 volt supply to rear quarter glass motor harness multiplug.

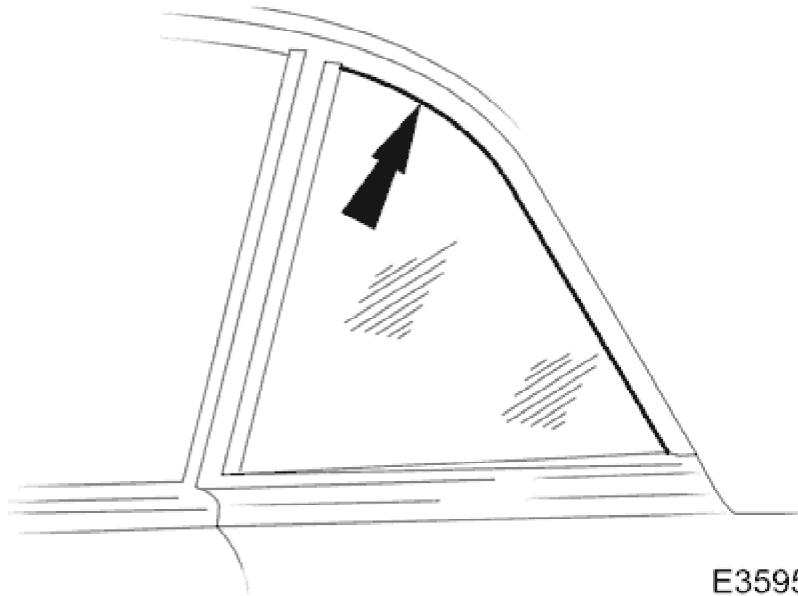

E35950

11. Carefully motor rear quarter glass up to just contact top seal.
12. Carefully close adjacent door ensuring glass does not contact rear quarter glass.

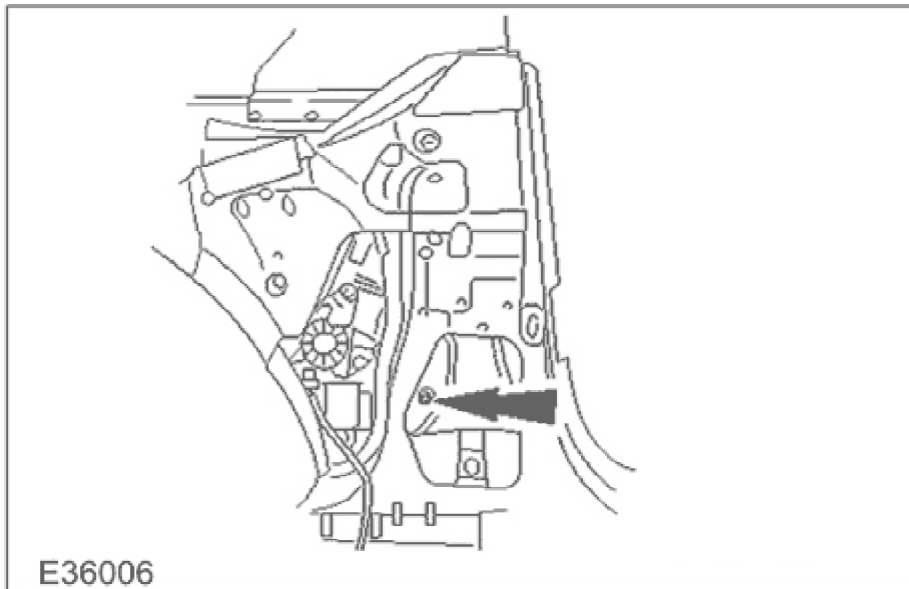

E36006

13. Slacken lower adjuster locknut.

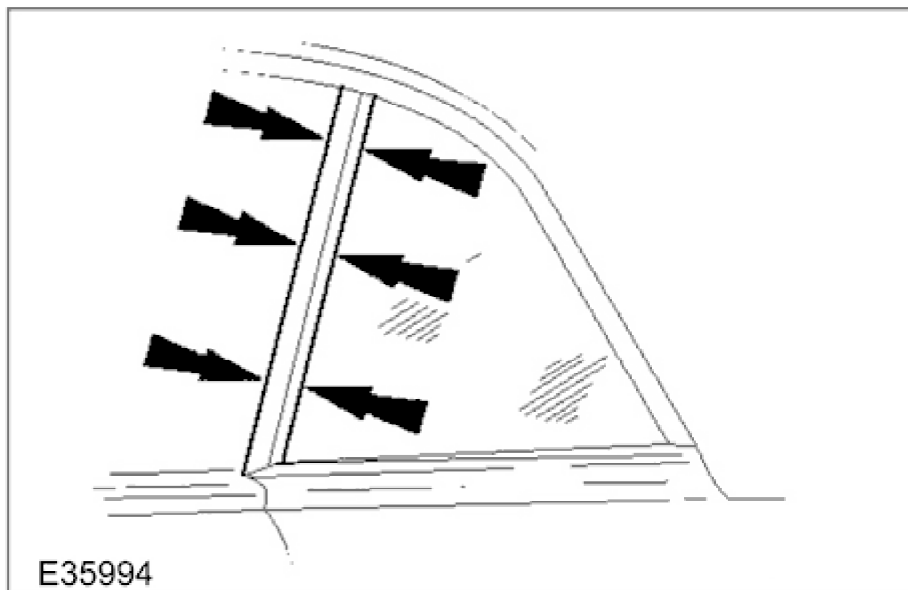

14. Move rear quarter glass to achieve a parallel 15mm gap between front edge of rear quarter glass frame and rear edge of door glass.

15. Tighten lower adjuster locknut.

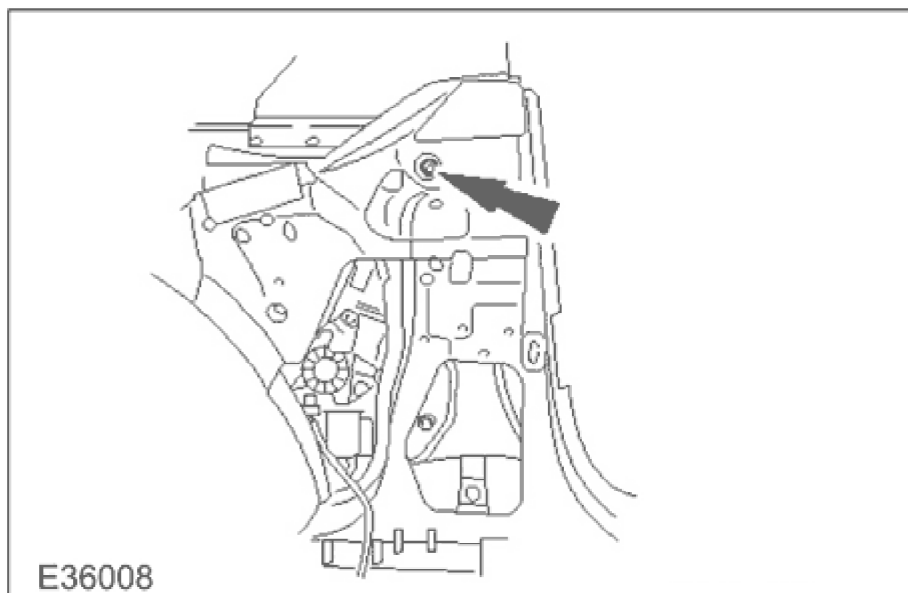

16. Slacken upper adjuster locknut.

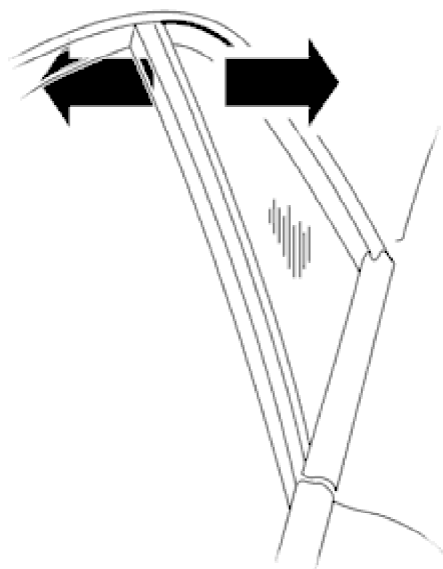

E35951

17. Turn upper adjuster to achieve lateral alignment of rear quarter glass upper edge with top seal.

18. Tighten upper adjuster locknut.

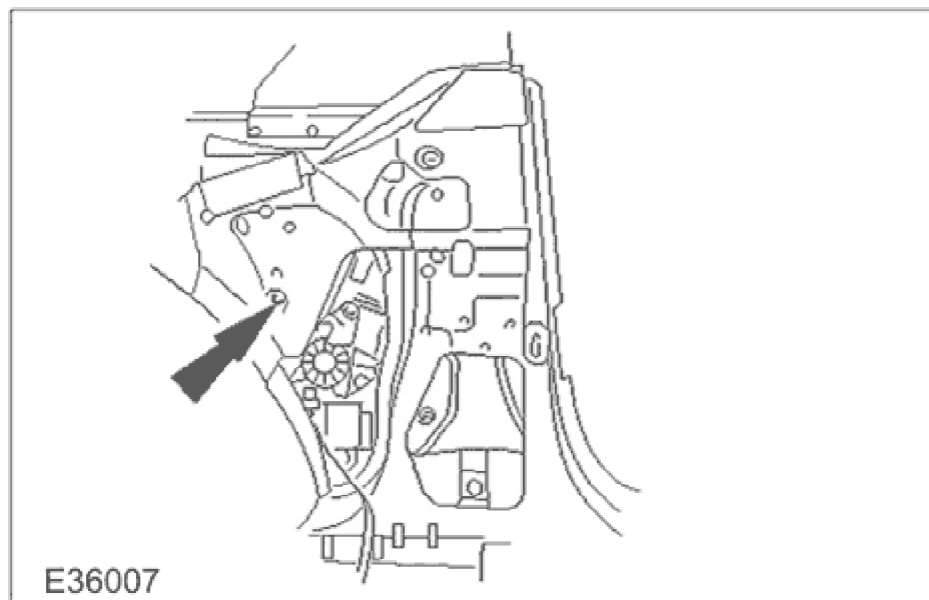

E36007

19. Slacken rear adjuster locknut.

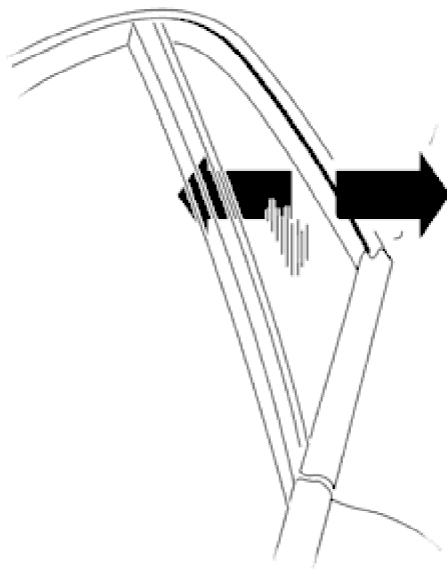

E35952

20. Turn rear adjuster to achieve lateral alignment of rear quarter glass rear edge with top seal.
21. Tighten rear locknut.
22. Fully raise rear quarter glass, check alignment with seals and adjust as necessary.
23. Disconnect 12 volt supply from rear quarter glass link lead multiplug.
24. Connect rear quarter glass motor link lead to harness multiplug.
25. Connect ground cable to battery terminal and fit battery cover. Refer to <<86.15.15>>.
26. Turn ignition key to II, fully lower and raise convertible top, turn ignition key to position O.
27. Check rear quarter glass alignment with top seal and re-adjust as necessary.
28. Turn ignition key to II, fully lower and raise convertible top, turn ignition key to position O.
29. Finally check rear quarter glass alignment with seals.
30. Install rear speaker assembly. Refer to <<86.50.12>>.
31. Install rear quarter casing. Refer to <<76.13.73>>.
32. Install rear quarter casing capping. Refer to 76.13.76.

2001 XK RANGE - Glass, Frames and Mechanisms - 501-11

33. Install rear seat cushion. Refer to 76.70.37.

34. Install rear seat squab. Refer to 76.70.38.