

## DIY Pulling and troubleshooting the ZF 6HP26 Mechatronics Unit E-shift Unit

pulled from various sources by Wilson009

**Experience with your car:** Advanced

**Eliminated:** You have already ruled out IVM, Battery, Alternator and changed your transmission fluid before. Or are getting ready to and feel confident it goes beyond fluids.

**Symptoms:** Car would go into Failsafe mode when shifting from 1-2 and 2-1. Would frequently happen in Parking Lots and Stop Lights. Issue would go away for a little bit when I changed the transmission Fluid and took it for test drives, but would come back worse after driving it to work. Car would sometimes not go into Park. Had to shutoff engine to get it to go into park. I drive would say P range unavailable.

Errors present: (note other factors/conditions including low transmission fluid can also generate some of these errors in addition 1 can also cause a domino effect of the other errors.)

4F4B Symptom gear check

4F4C Symptom speed Monitoring/gear check

4F4D Gear 1 Monitoring also known as P0731 (did some homework on p7031 and found in Ford which also uses ZF that it referred to Gear 1 Ratio Incorrect which was a turning point for me)

4F56 Shift Monitoring

507D Parking lock put out, defective incorrect disengage

507C Parking lock put in, defective

Note: This is based on a 2002 745i Most of this applies all the way up the line but there may be slight variations. Use realoem.com to get your part #'s

Tools:

- Ohm Meter
- Torx Bit set
- Torque wrench
- INPA loaded to your laptop with connection

Equipment

- New Transmission Pan
  - \$115 on ebay or USAautoparts.net a lot more if you go OEM
    - I found the specs and quality to be identical to the OEM
- 8 qts of Castro Import Multi-Vehicle ATF or OEM if you really want to
  - Castro has been used multiple times by many people in this form without issue



- - Recommended Order New Pan Bolts from the dealer the for some years. Out bolts torx size is too small and they strip easy as a result. The new bolts take a larger torx bit.
  - The following parts should be replaced regardless of whether they are broken or not. Do it while you have it accessible
    - 4 sealing sleeves
    - 1 Bridge seal adapter
    - Mechatronics Sealing Sleeve
  - Absorbent material (cat litter at the autostore) This is a very messy job and you will spill oil everywhere including your hands and maybe your head at some point.
- 
1. Drain your oil and dispose or reuse if you just replaced it recently if you want
    - a. Make sure you can open your Fill plug before draining
  2. Unbolt your transmission Pan. If you strip the torx bolt use channel locks.

- a. Recommend replacing your bolts

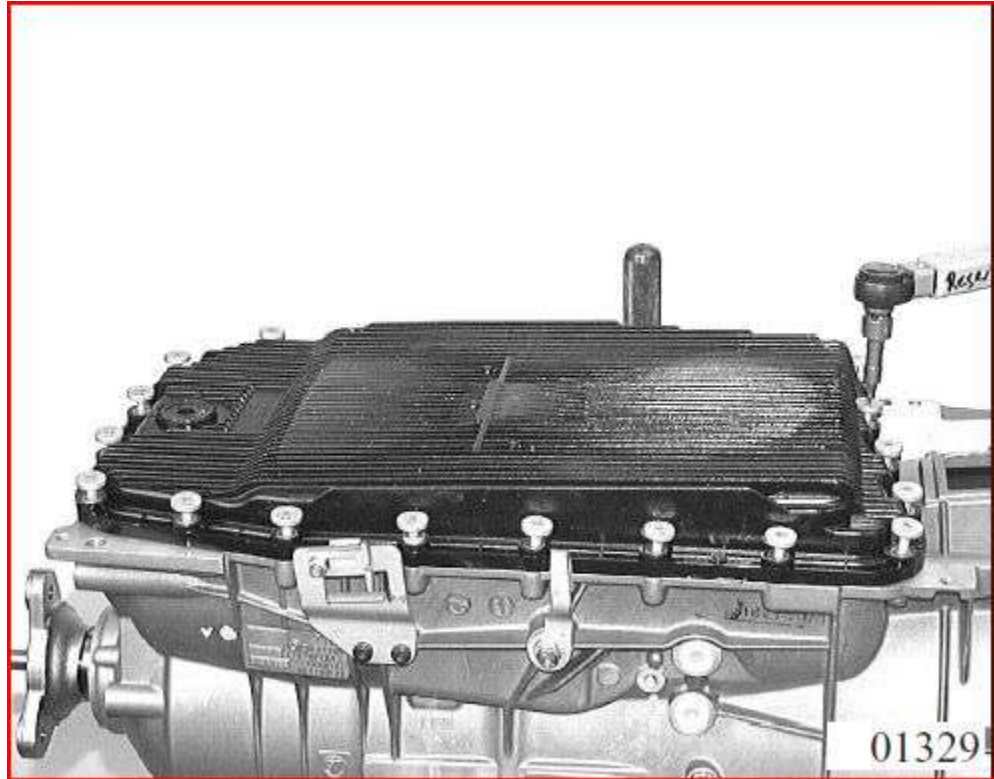

3. Dispose of you old transmission pan but before you do tear it apart to inspect the filter to see how much metal is in it. Also inspect your magnets. Mine and Keifers were fairly coated which I think is normal after 120K.
4. Tie back the Brake Cable



5. Unbolt the Mechatronics Unit. \*Note all bolts bolting the Mech to the transmission are T40 Torx so you can't get confused. Using the Guide on the left started and 10 and go backward gently loosening each bolt until you can lower it down.

- Use hand tools – do not use power tools for screw installation. Improper torque of the mechatronic mounting screws will cause erratic transmission operation.

First install and turn screw 1 and 4 alternately until seated then install all other screws until they make contact with the mechatronic. After all screws are installed, tighten screws in order 1 through 10 or 1 through 13 as shown in the schematic below.

Torque for screws is  $8 \text{ NM} \pm 0.8 \text{ Nm}$ .

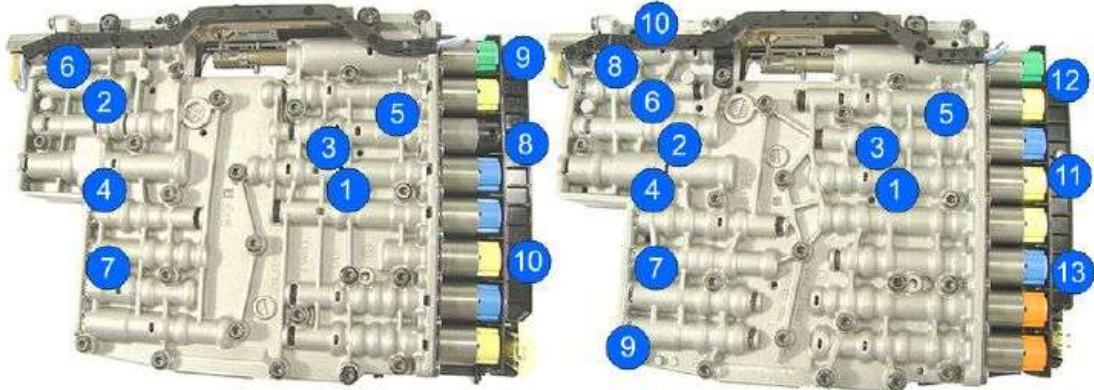

7



6. Now that the mechatronics is out you need to Ohm Test each Solenoid. EDS 1-6 (blue and Yellow caps) Solenoids have a resistance of around 5 ohms while MVS 1-2 (black caps ) solenoids resistance is 12 ohms. MVS 3 (green cap) solenoid resistance is 25 ohms.

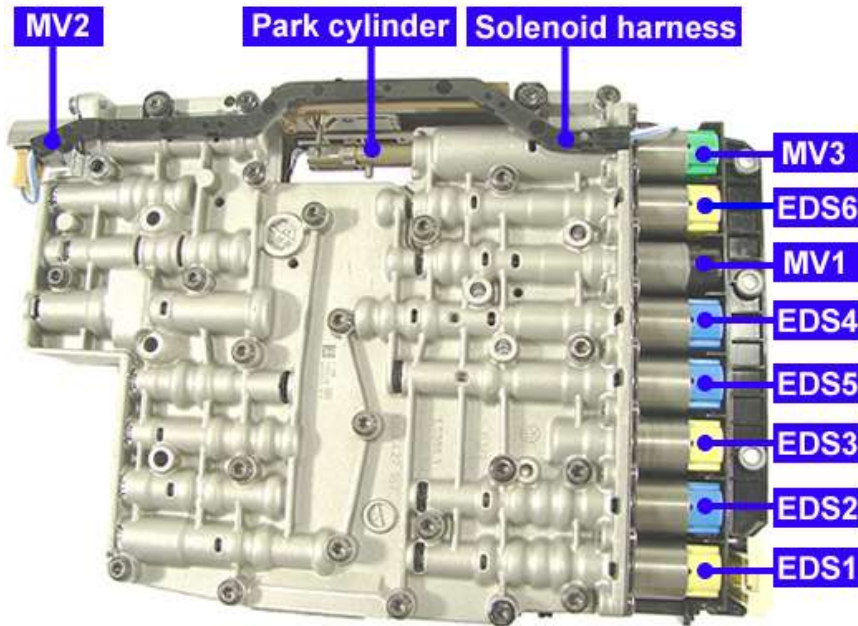





Figure 1 pic of Park Cylinder

7. This is where I found my parking lock error. MV2 which is responsible for that and an open circuit or a reading of 1. I ordered a replacement from ZF distributor Errickson Industries for \$60 bucks. Excellent company very friendly. Contact is Nat [www.erikssonindustries.com](http://www.erikssonindustries.com) 800-388-4418 in CT. Had my package in 2 days. This fixed my Parking Lock errors.



Figure 2 Bad Solenoid also broke off plastic in there from harness. I think i did it while inspecting it.

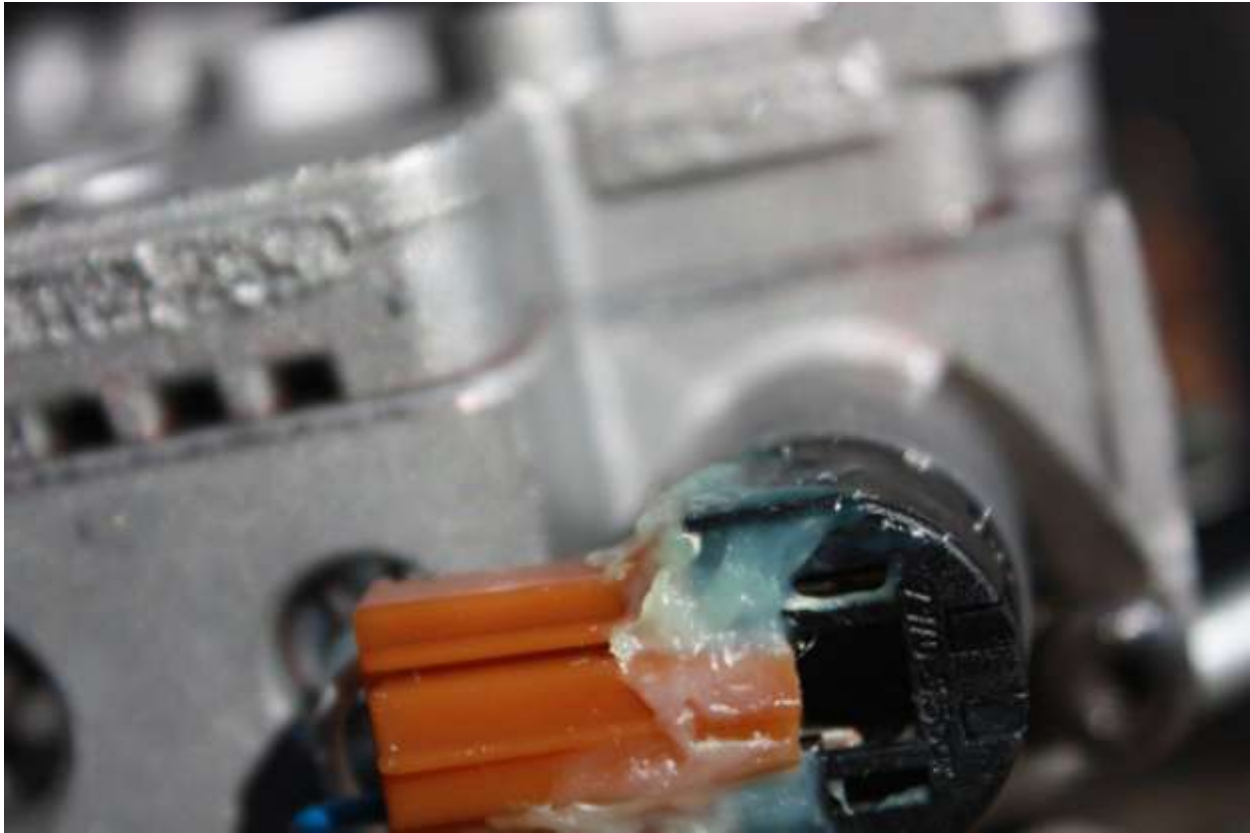

Figure 3 New Solenoid with Harness glued in tight.

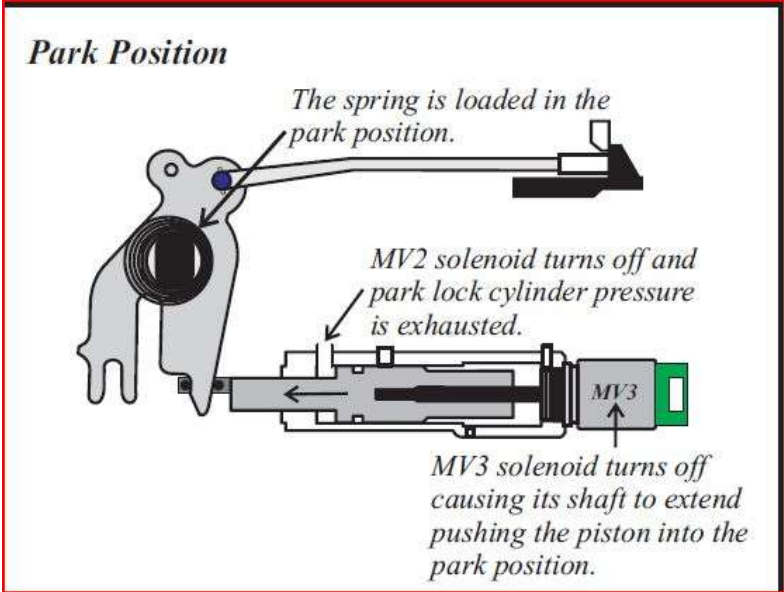

Figure 4 Shows MV2 Function which malfunctioned on my car

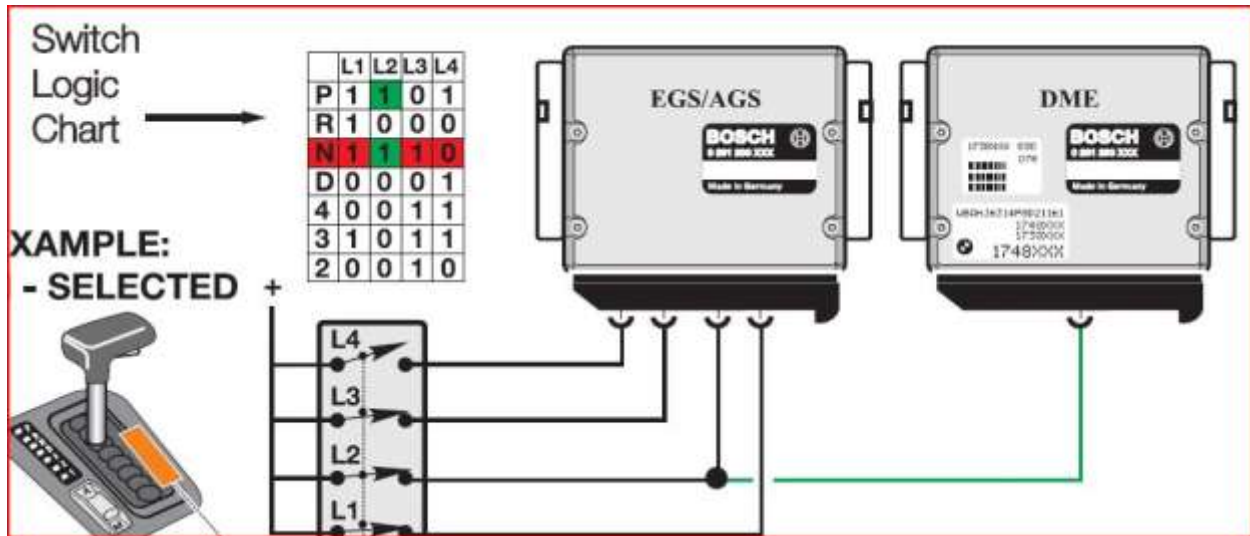

Figure 5 This caption shows how shifting is applied where L1 = EDS1 etc

## MV Solenoids

Magnetic Valve (Shift) Solenoids (MV). Controlled by a switched (on/off) power or ground signal from the TCM. The valves have two positions open or closed. Some are normally open and close when activated and some are normally closed and open when activated.

MV solenoids are for:

- Controlling shift valve position
- ON/OFF control of TC lock up clutch
- Reverse Lock Out protection (early systems)
- Band Brake Activation (system specific)
- Shift lock control

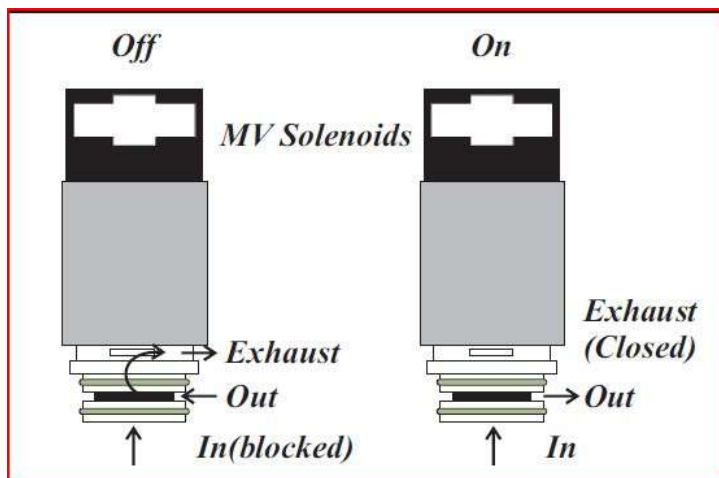

Figure 6 Functioning of MV Solenoids



Pressure Regulator solenoids (EDS). Controlled by a Pulse Width Modulated (PWM) control signal from the TCM provides an adjustable positioning of the valve. The variable position makes these valves suitable for varying control pressures.

Pressure Regulator valves are used for:

- Maintaining operating pressures
- Gradual TC Clutch lock up control
- Overlap shift control (system specific)
- Band Brake Activation (system specific)

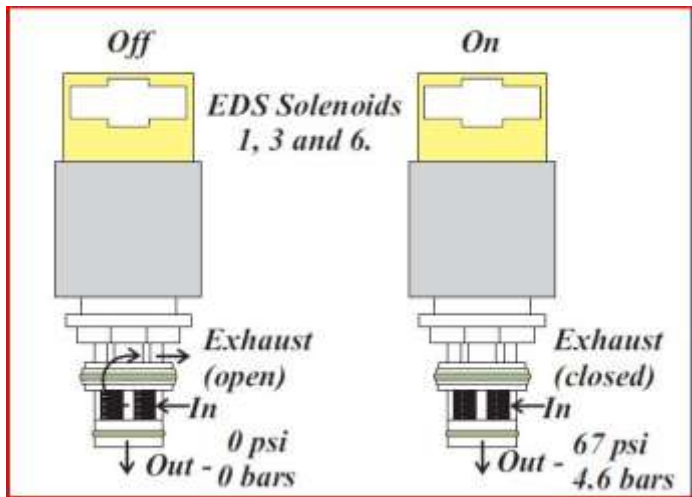

Figure 7 EDS 1 3 6

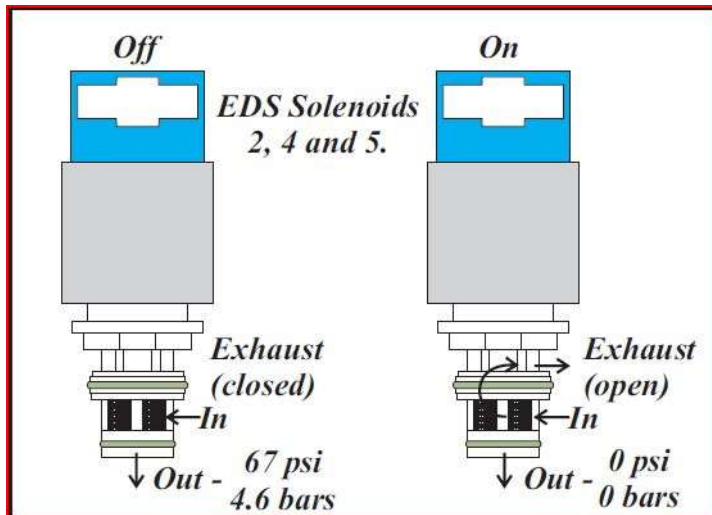

Figure 8 EDS 2 4 6

8. I then moved on to the 4F4D Gear 1 Monitoring also known as P0731 as this was the Primary error I was getting the others were secondary. I discovered this is referred to Output Speed problem by referencing some Ford documents.

P0731	Slip detected – First gear	Drive vehicle; accelerate rapidly	2	√	√	Transmission oil level low Output speed sensor problem (Refer to P0721 and P0722 Possible Causes) Engine speed signal circuit between ECM and TCM: open circuit, short circuit, or high resistance Transmission mechanical failure
-------	----------------------------	-----------------------------------	---	---	---	---

Figure 9 Reference on P0731

The mechatronics has a few crucial sensors on it.

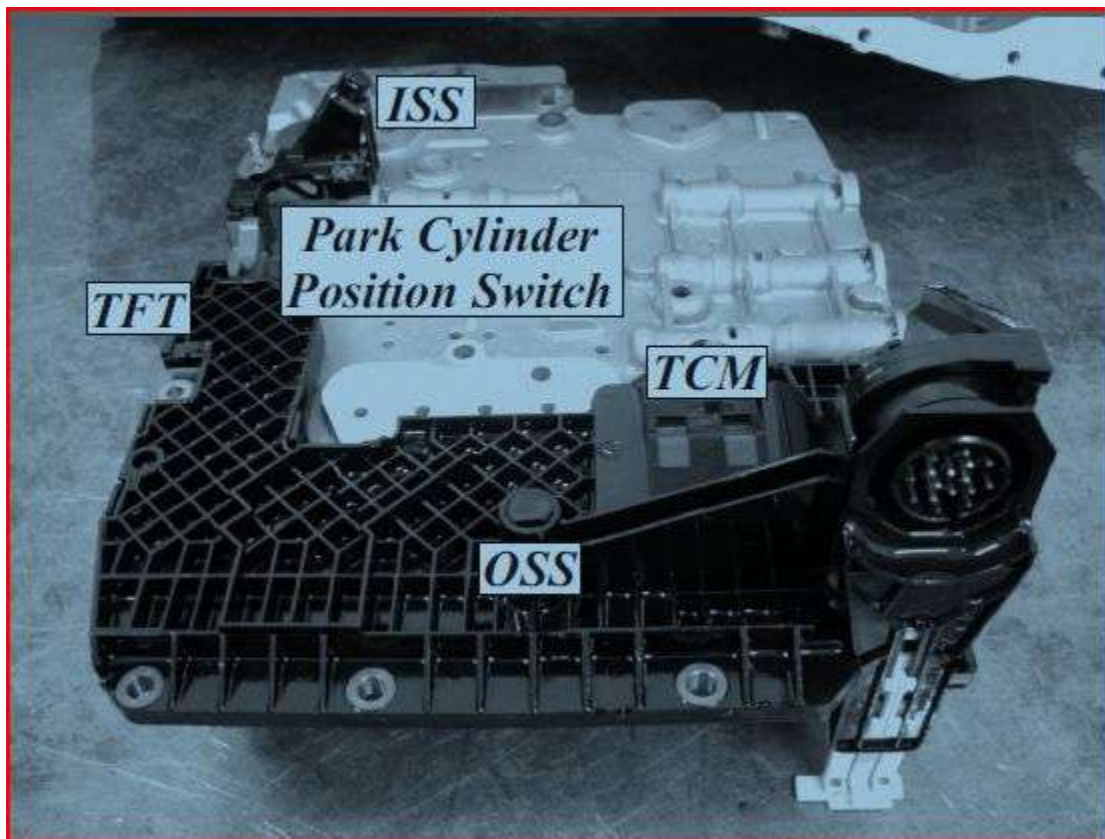

ISS-- Turbine Speed Sensor This Analog inductive sensor produces an A/C sine wave similar to an ABS/ASC wheel speed sensor. The signal frequency is proportional to the rotation speed of the monitored component. The speed sensors are used to monitor clutch slip for plausibility and shift points as well as maintaining adaptive hydraulic pressures.

OSS-- Output Speed Sensors. The description of ISS applies to this as well

Park Cylinder Position Switch --Monitors the position of the Park Cylinder with E-version

TFT --Temperature Sensor This TFT resistor provides a variable voltage drop proportional to transmission oil temperature. The TFT is soldered into the oil temp circuit of the wiring harness located in the transmission oil sump.

TCM--Transmission Control Module The TCM controls the hydraulic valve body by activating specific electrical solenoids and pressure regulators. The component locations within a transmission in relation to activation of shift components (multi plate clutches and brakes, band brakes, freewheels) control and direct the powerflow through the planetary gearset(s) providing various output ratios. By design, each transmission manages powerflow uniquely with a common goal of providing progressive output ratios.

\*Notes Inspect the plastic body for any cracks any fluid penetrating the plastic will hose up the unit. The Plastic piece can also be taking apart so that. It looked difficult so I did not attempt. But the individual pieces may be worked on this way if your desperate.

### **Metallic Contamination**

The ISS and OSS are used by the TCM and higher to calculate shifting ratios. If these sensors are impeded and give unexpected readings a gear ratio error will occur. . I also had notice a thin grey film on the valve body almost like anti-seize. Very fine metal.

9. I then was pointed via a friend of a friend located in Denver Colorado Plues Transmission [www.pluestransmissionparts.com](http://www.pluestransmissionparts.com) They were able to find information about metallic contamination affecting Ford cars with the ZF Transmissions

\*Note at this point I am working on theory but the logic made sense and my problem went away.

10. Remove the bolts that hold the valve body and the TCM together and carefully slide them apart. Any metal coating on these can mess up reading as well as impede contacts and signals. Now Clean the valve body and TCM. I used Paper Towels and Brake Cleaner and Qtips.

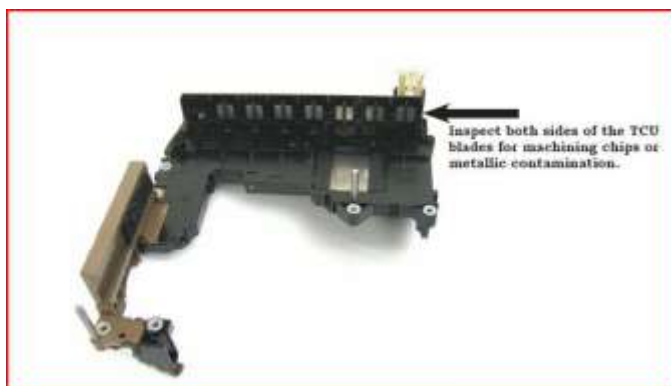

Figure 10 Spray and Clean and inspect for Cracks. This unit can also be opened

**NOTE: Inspect the terminals thoroughly, any type of contamination can cause this problem.**



**Typically the contamination is caused by clutch debris.**



**NOTE: Inspect the terminals thoroughly, any type of contamination can cause this problem.**





Figure 11 Note Film on TCM These contacts are necessary for functioning



Figure 12 Clean all your contacts





Figure 13 Take a look at this ISS Sensor. It is covered in Fine Metal which affects the readings! Clean it off

11. Once everything is clean put it apply Foam Strip. Ordered form Erickson as well and torque to 8nm being careful not to over tighten.

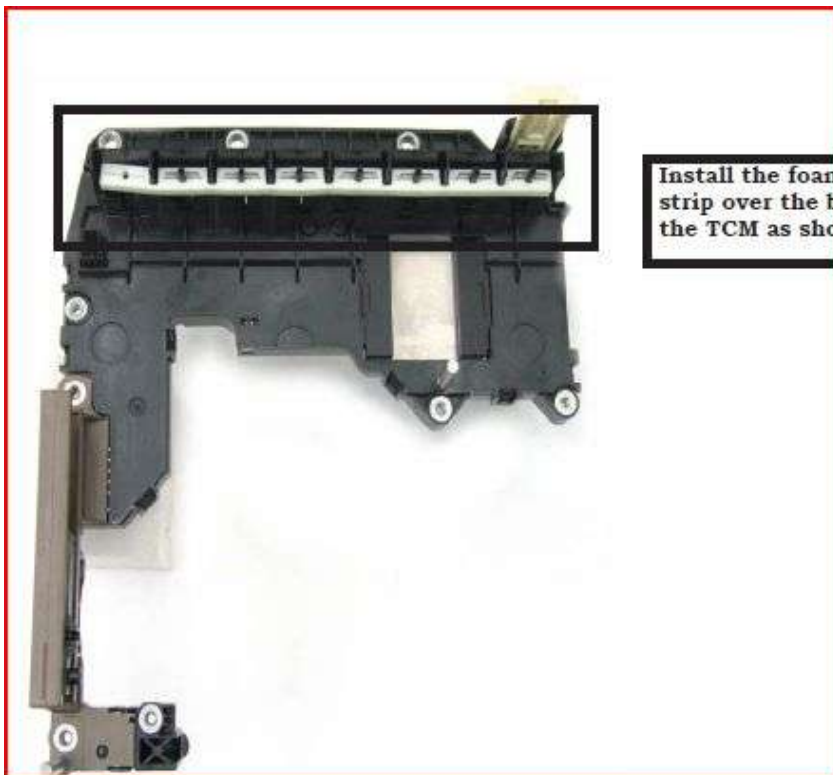

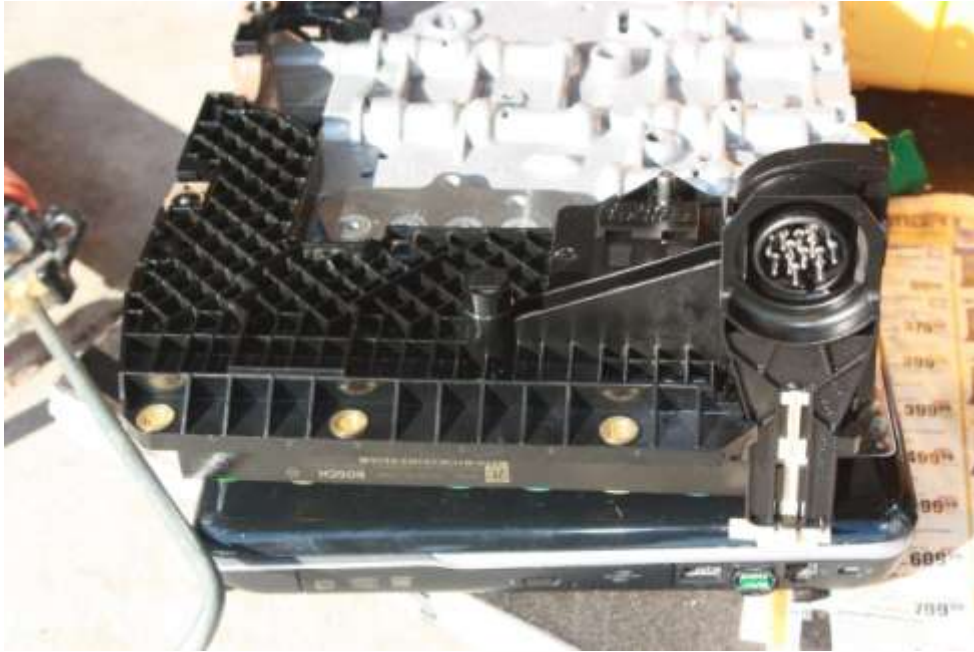

Figure 14 All Clean and back Together

12. Install the sealing Sleeves and Bridge Adapter



Figure 15 Bridge Seal adapter Fits Here. This seal is Prone to Cracking



Figure 16 The 4 Sealing Sleeves Replace while its easy



Figure 17 Old Sleeve Left New Right

- Reinstall the Mechatronics Unit and electrical Plugs and Mechatronics Sealing Sleeve. Follow other guides for the details on this. See [www.ctsc.com](http://www.ctsc.com) for detailed instructions if this guide gets separated from it.

Use hand tools – do not use power tools for screw installation. Improper torque of the mechatronic mounting screws will cause erratic transmission operation.

First install and turn screw 1 and 4 alternately until seated then install all other screws until they make contact with the mechatronic. After all screws are installed, tighten screws in order 1 through 10 or 1 through 13 as shown in the schematic below.  
Torque for screws is  $8\text{ NM} \pm 0.8\text{ Nm}$ .

7

Figure 18 Use Pic on Left. Do not overtighten! 8nm



Figure 19 Mechronics Sealing Sleeve

#### 14. Button up the Transmission Pan

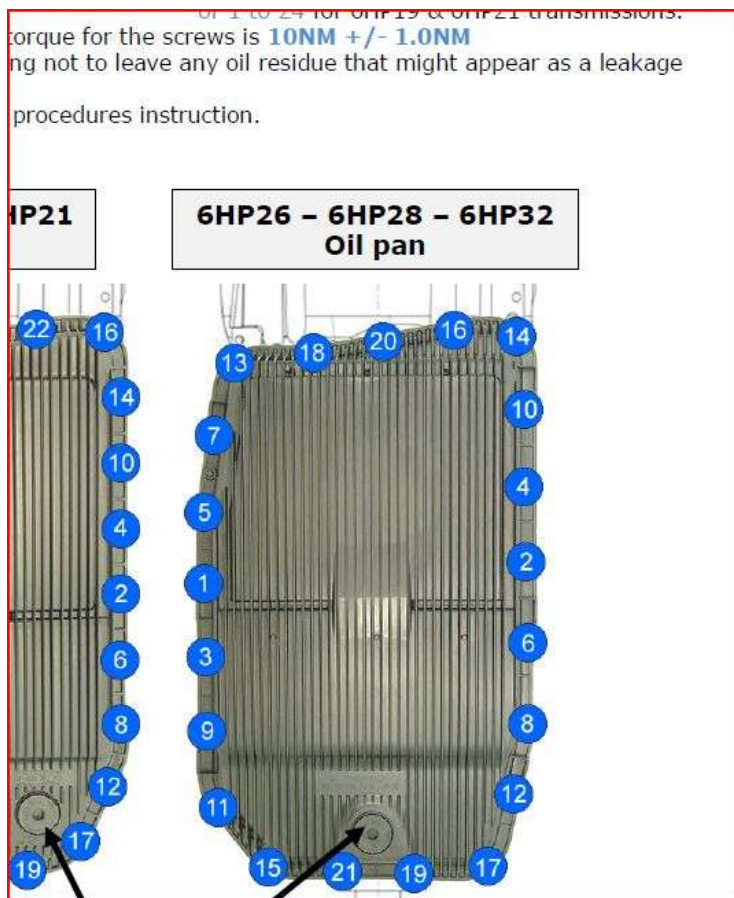

Figure 20 Follow the order started at 1. Tighten to 10nm



15. Fill Transmission Pan with Fluid until it spills out (about 3-4 Qts). Leave Fill plug open
16. Turn on Car Pump another 4 qts in. After you get the first 2-3 qts in quickly get in drivers seat and put it in Drive, Neutral and Reverse a few times. Then get back out and keep pumping.
17. When full warm fluid will begin to slowly drip out. \*pump it fast otherwise it will come out Hot! When drip becomes a small stream put fill Plug back in. You should be good to go now.

\*Note If you turn off the car while the fill plug is open, after you've added the additional oil, It will all come running back out!

18. Clear all your error codes and Take her for a test drive. Your done!

#### Additional Notes on the Mechatronics/Transmission Dynamics

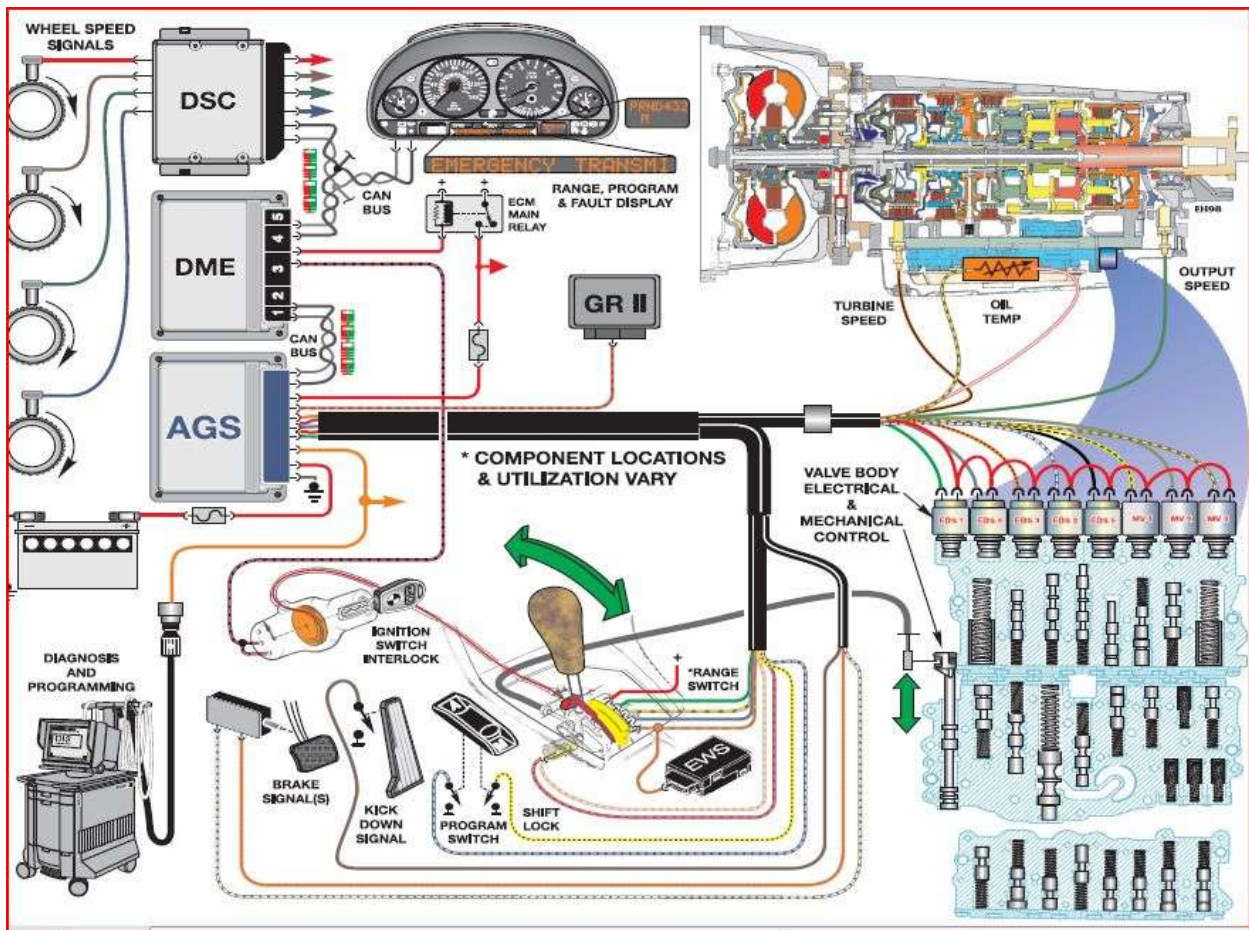

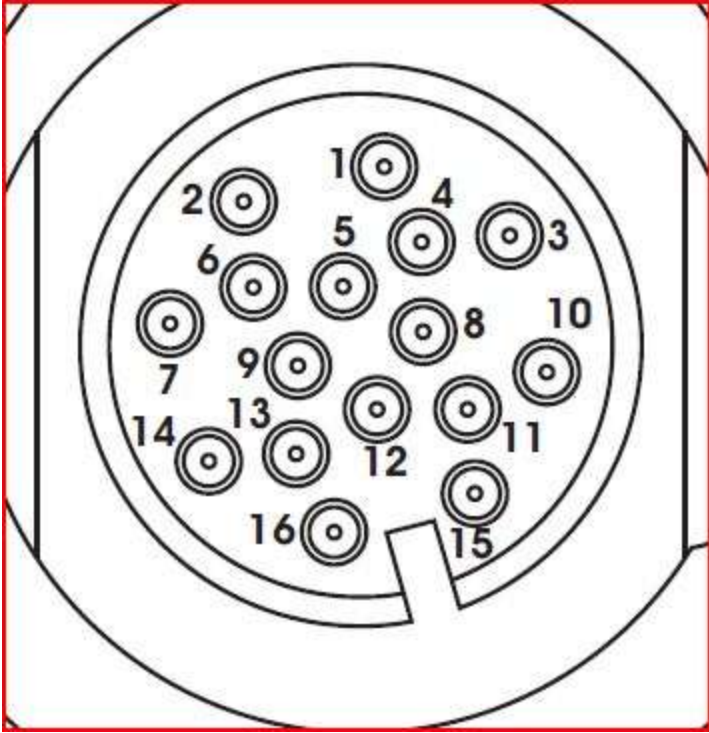

Figure 21 Mechtronic Adapter Pin locations

<b>PIN #</b>	<b>FUNCTION</b>	<b>NOTES</b>
1	SERIES LINE	AVAILABILITY LINE FROM STEERING COLUMN SWITCH CENTER
2	CAN L	CAN LOW
3	ISO K	K LINE
4	NOT IN USE	
5	NOT IN USE	
6	CAN H	CAN HIGH
7	NOT IN USE	
8	NOT IN USE	
9	TCM TERMINAL 15	WAKE-UP SIGNAL
10	“P” SIGNAL	P LINE FOR STARTER INHIBIT
11	NOT IN USE	
12	NOT IN USE	
13	TCM TERMINAL31-1	GROUND
14	TCM TERMINAL 30	PERMANENT POSITIVE (EGS SUPPLY VOLTAGE)
15	NOT IN USE	
16	TCM TERMINAL31-2	GROUND

Copyright © 2008 A

Figure 22 Mechtronic Pin Functions