

# 1998 XK RANGE - Convertible Top - 501-18

## Convertible Top Headliner 76.86.16

### Removal

1. Remove carpet from convertible top stowage compartment.

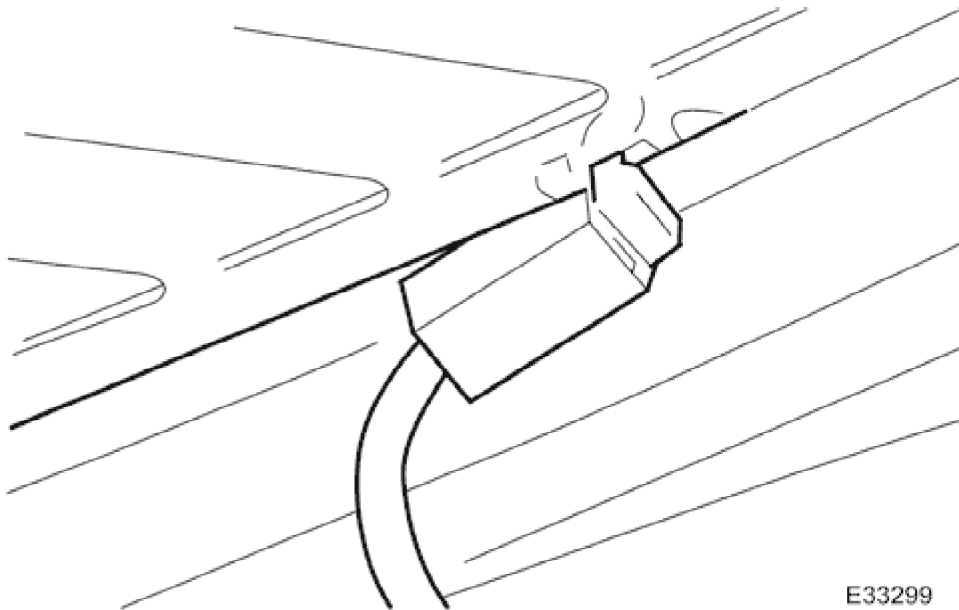

E33299

2. Disconnect heated backlight harness connectors and position harness clear of top.
3. Power top to fully down position.
4. Remove rear seat cushion. Refer to <<76.70.37>>.
5. Remove rear seat squab. Refer to <<76.70.38>>.
6. Remove rear quarter casing cappings Refer to <<76.13.73>>.
7. Remove rear quarter casings. Refer to <<76.13.73>>.
8. Remove rear speaker -Premium ICE only. Refer to 86.51.06.

## 1998 XK RANGE - Convertible Top - 501-18

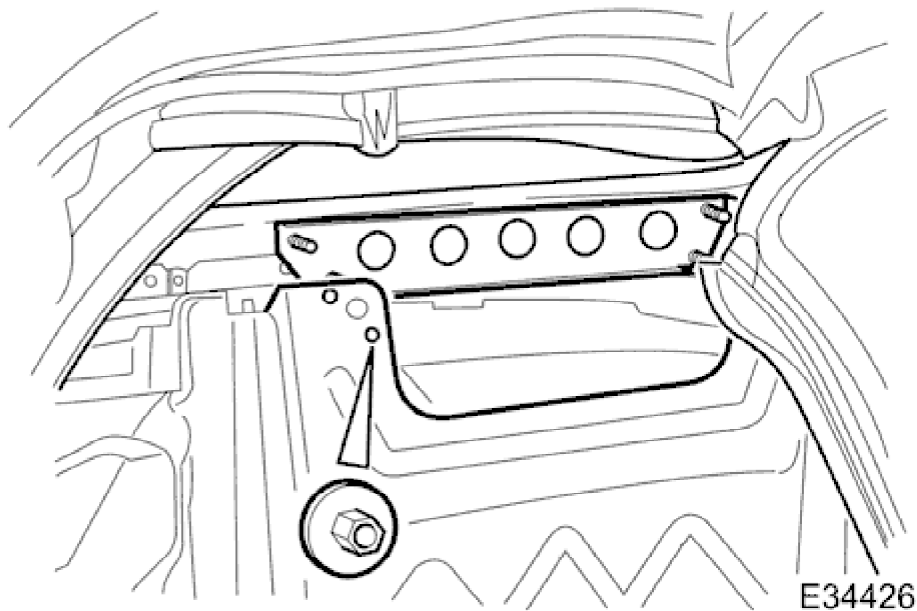

9. Slacken and remove squab panel stiffener bracket to body securing nuts and remove bracket.

10. **NOTE:**

Do not allow top to latch.

Power top to 3/4 closed position.

11. Remove battery cover and disconnect ground cable from battery terminal. Refer to <<86.15.19>>.

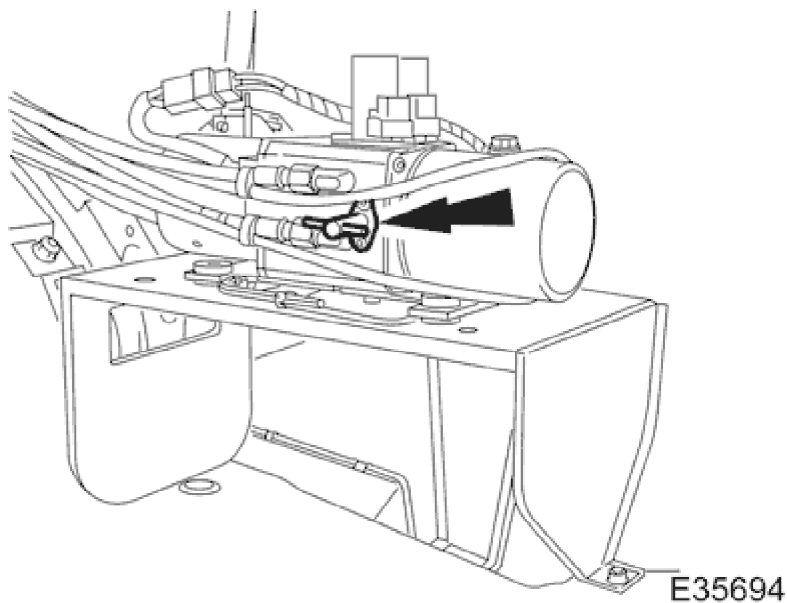

12. Position trunk RH liner for access and turn hydraulic pump valve fully counter-clockwise to manual operation position.

## 1998 XK RANGE - Convertible Top - 501-18

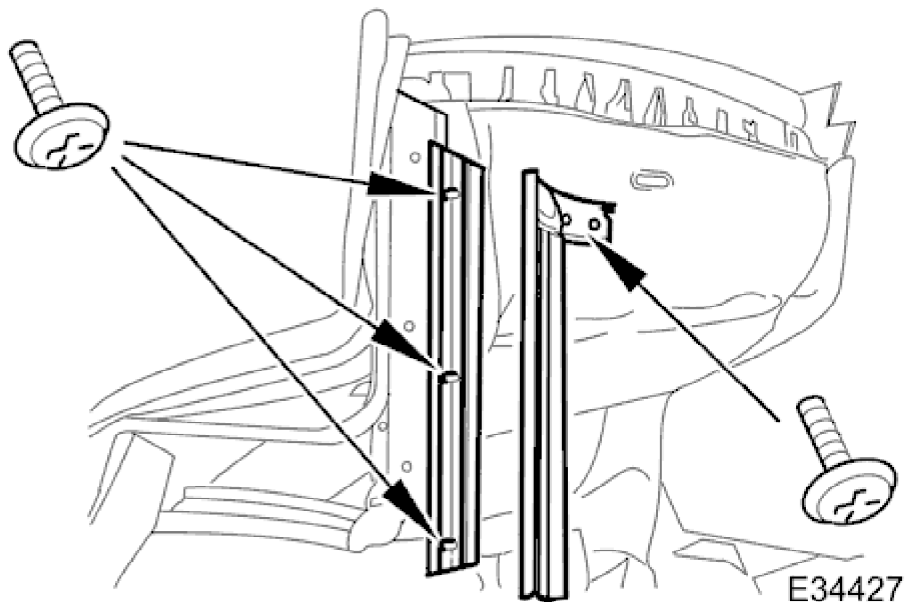

13. Remove LH cantrail seal and carrier.

- Slacken and remove screws securing LH cantrail seal to frame and withdraw seal.
- Slacken and remove screws securing LH cantrail seal carrier and remove seal carrier from vehicle.

14. Slacken and remove screws securing RH cantrail seal to frame and remove seal.

15. Slacken and remove screws securing RH cantrail seal carrier and remove seal carrier.

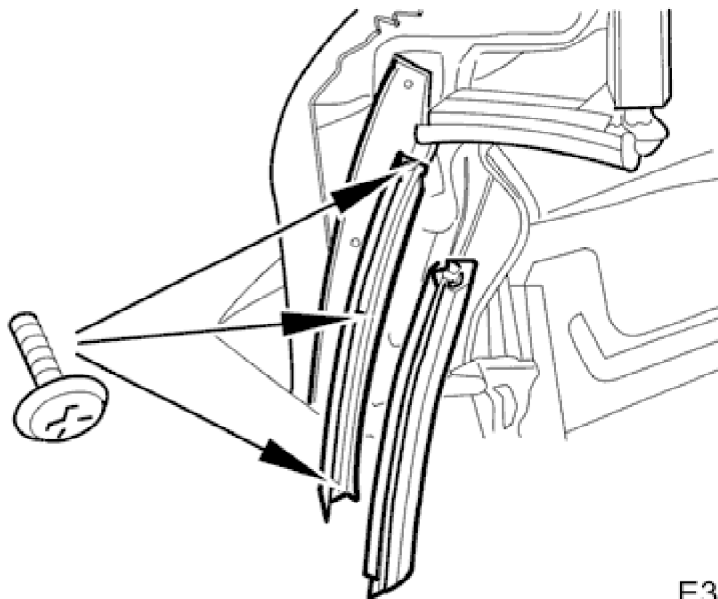

16. Remove LH main column seal and carrier.

- Withdraw LH main column seal from carrier.
- Slacken and remove screws securing seal carrier and remove carrier from vehicle.

## 1998 XK RANGE - Convertible Top - 501-18

17. Release and remove RH main column seal from carrier.

18. Slacken and remove screws securing RH main column seal carrier and remove carrier.

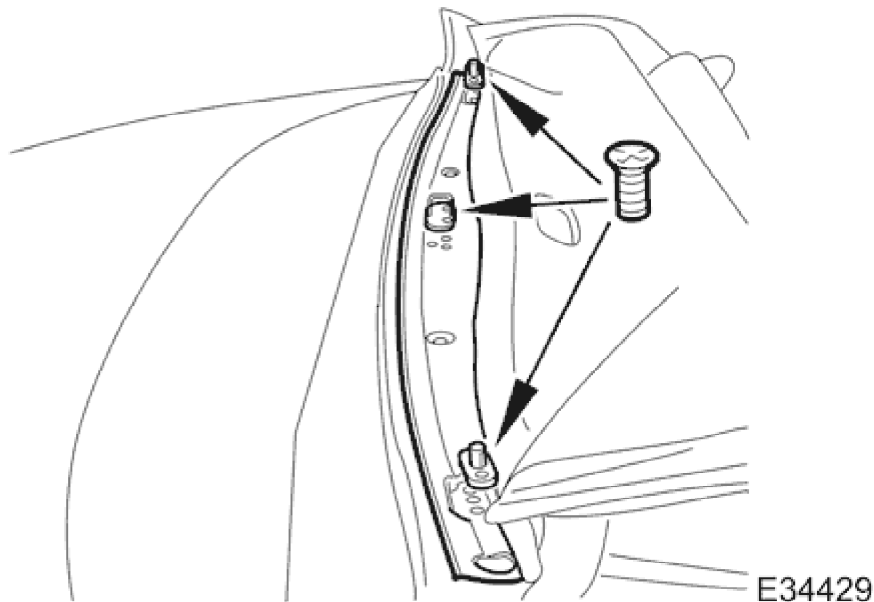

19. Remove latch striker and guide pins.

- Slacken and remove latch striker securing screws and remove striker from header plate.
- Slacken and remove screws securing latch plate guide pins to frame and remove guide pins.

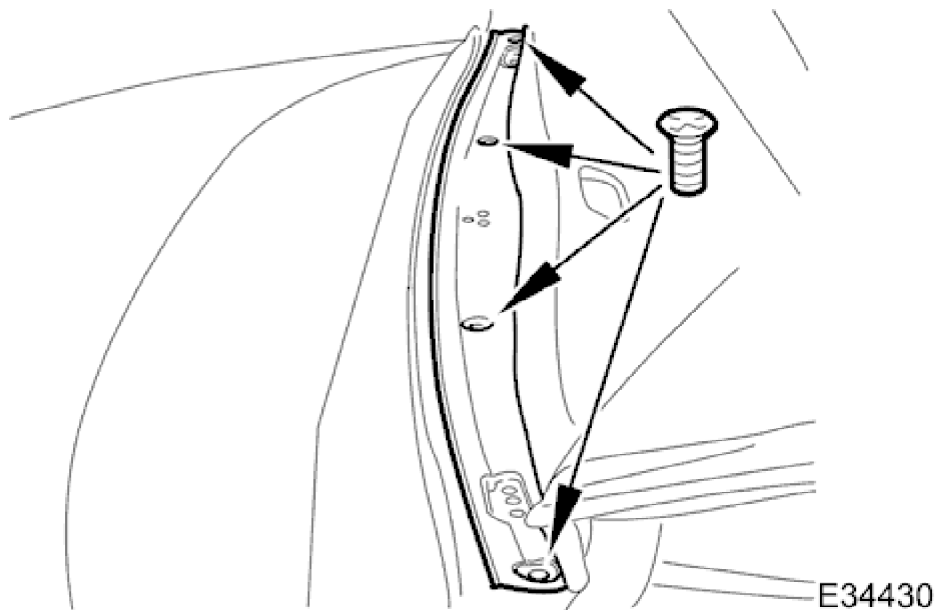

20. Slacken and remove screws securing latch plate to frame and remove latch plate.

21. Noting positions for installation, release bonded sections of cover from frame.

# 1998 XK RANGE - Convertible Top - 501-18

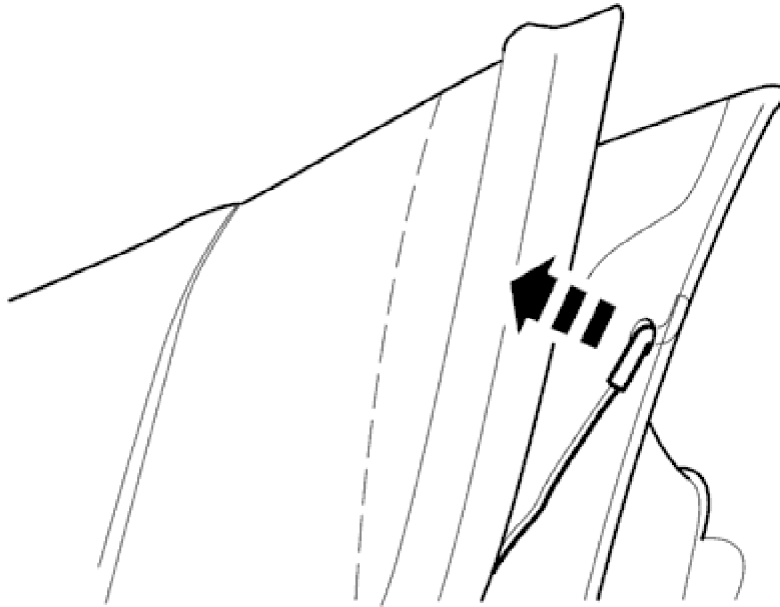

E34431

22. Disconnect roof side tension cables from frame.

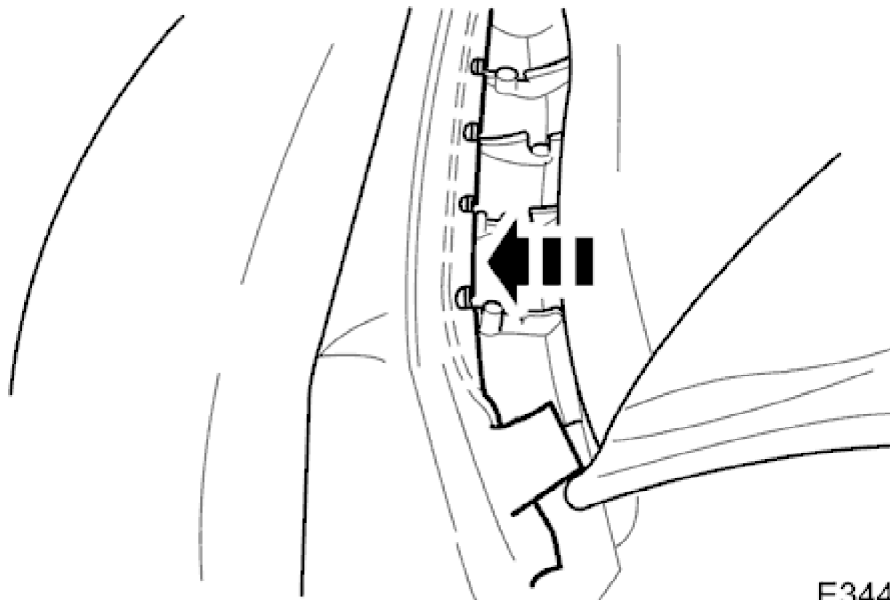

E34432

23. Release cover front retaining rod from retaining clips in frame and remove rod from cover.

## 1998 XK RANGE - Convertible Top - 501-18

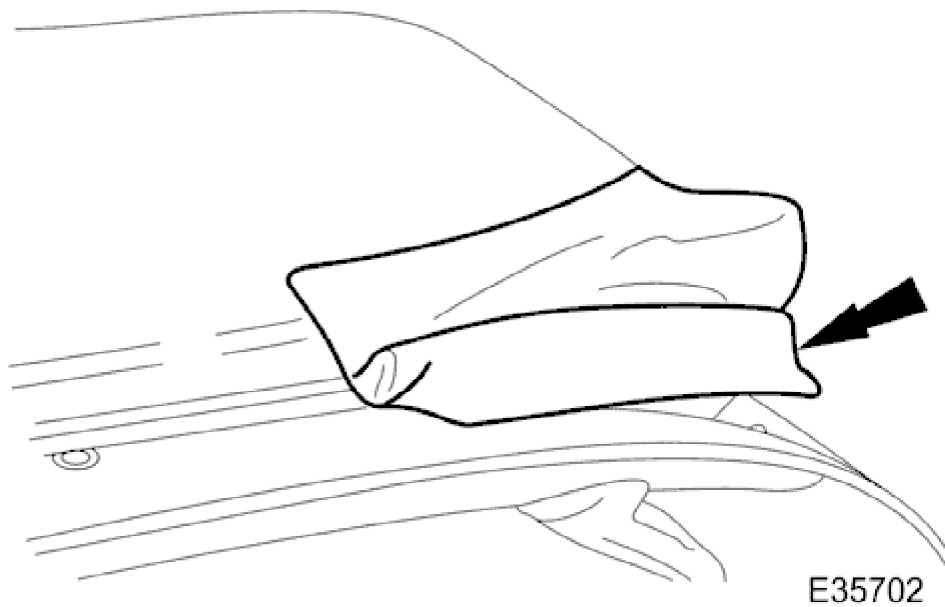

24. Noting the positions for installation, release bonded areas of padding bag from frame and withdraw bag from front of frame.

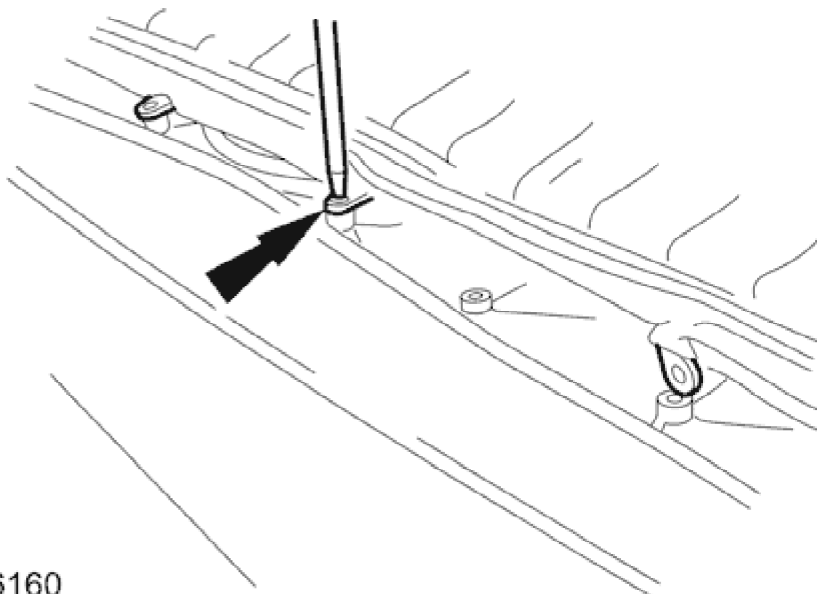

E36160

25. Slacken and remove eight screws and outer clips securing padding bag to frame.

26. Manually move top to fully raised position.

# 1998 XK RANGE - Convertible Top - 501-18

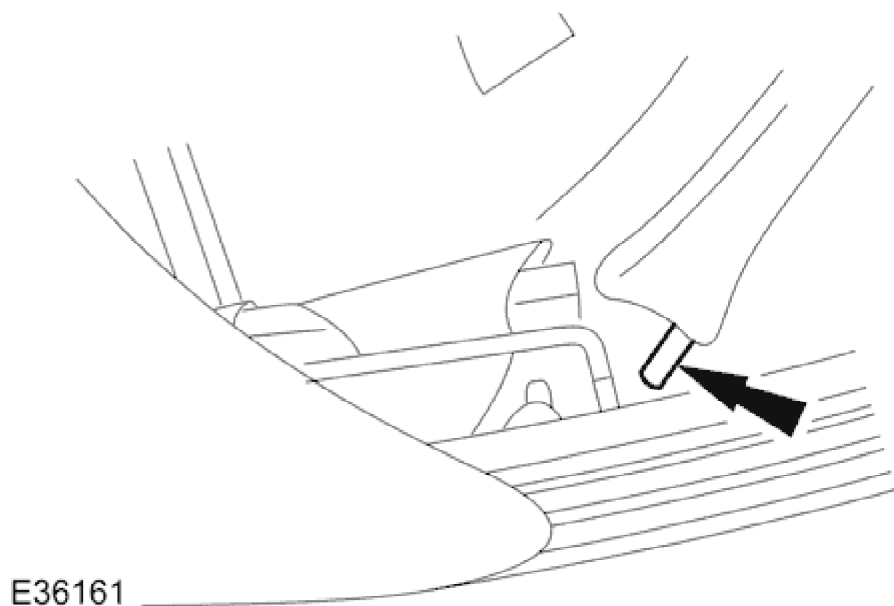

27. Position top cover and padding bag rearwards and release both headlining rear tension rods.

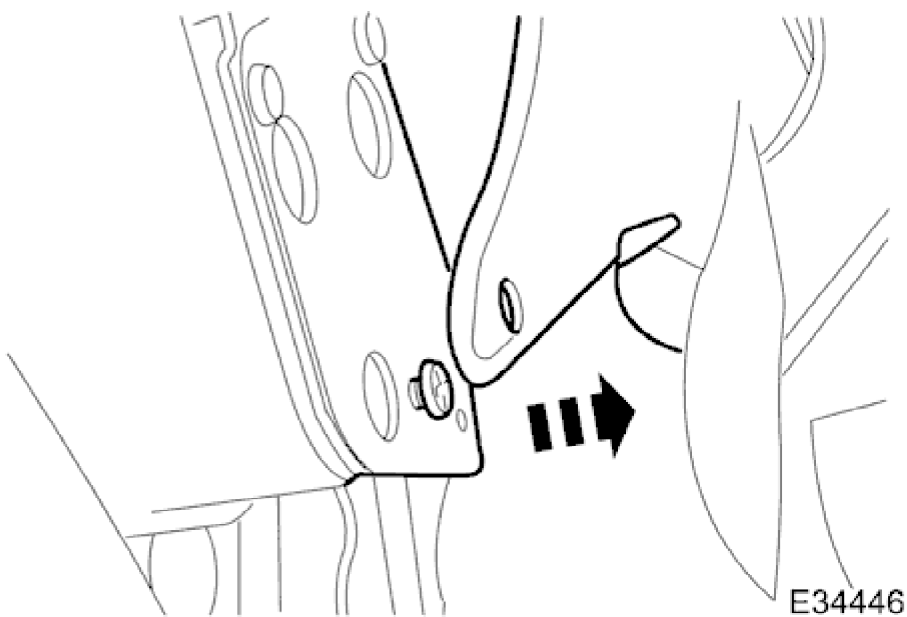

28. Slacken and remove screws securing headlining to main column bracket covers.

# 1998 XK RANGE - Convertible Top - 501-18

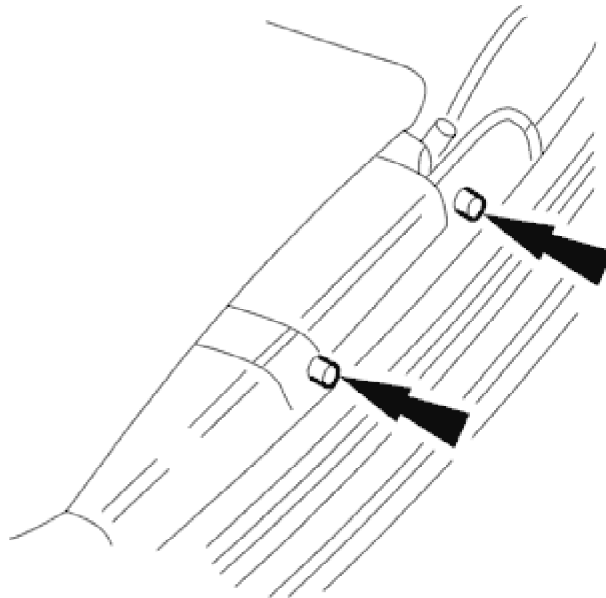

E36162

29. Drill out the two rivets each side, securing rear of headlining.

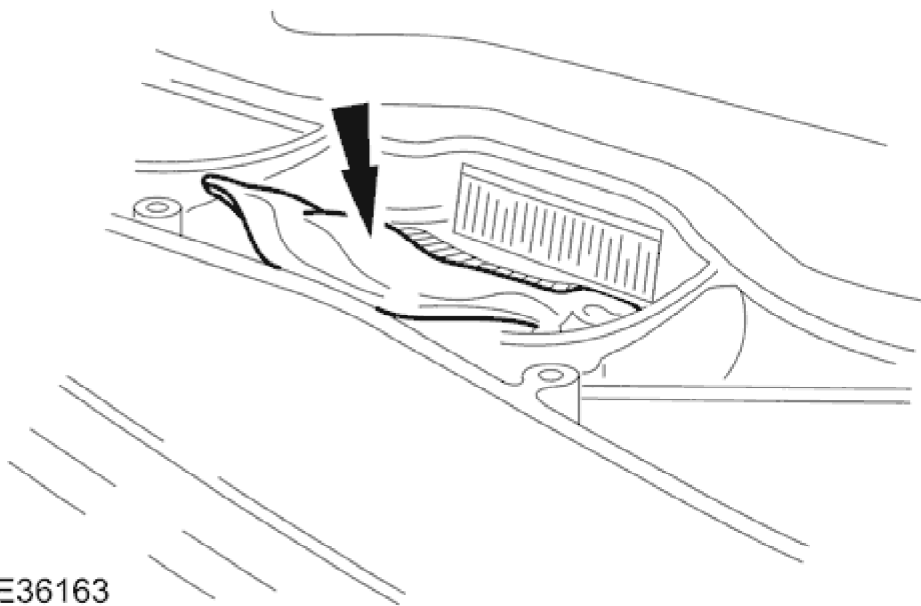

E36163

30. Release section of headlining secured by velcro strips to frame around pull-down handle aperture (bonded on early vehicles).



## 1998 XK RANGE - Convertible Top - 501-18

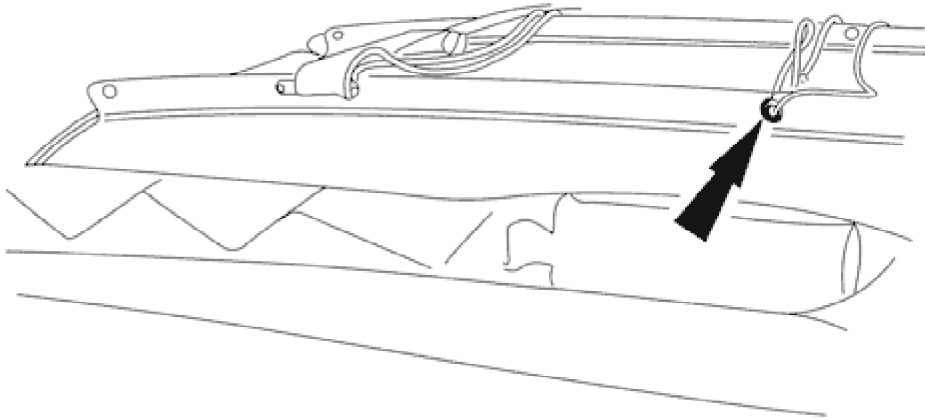

### E36164

31. Exercising care to avoid damaging cords, drill out the two pop rivets securing tension cords to frame.
32. Position tension cords for access.

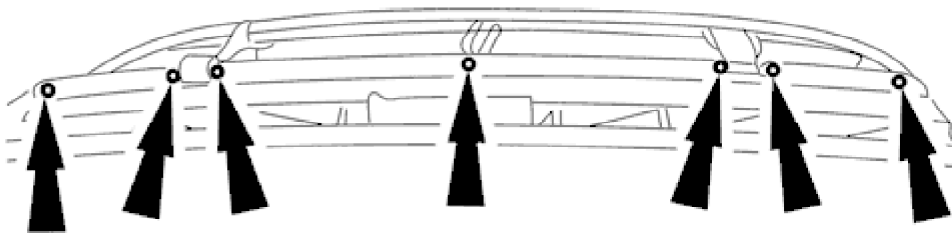

### E36165

33. Drill out the seven pop rivets securing front bow rail to top frame and remove rail.

## 1998 XK RANGE - Convertible Top - 501-18

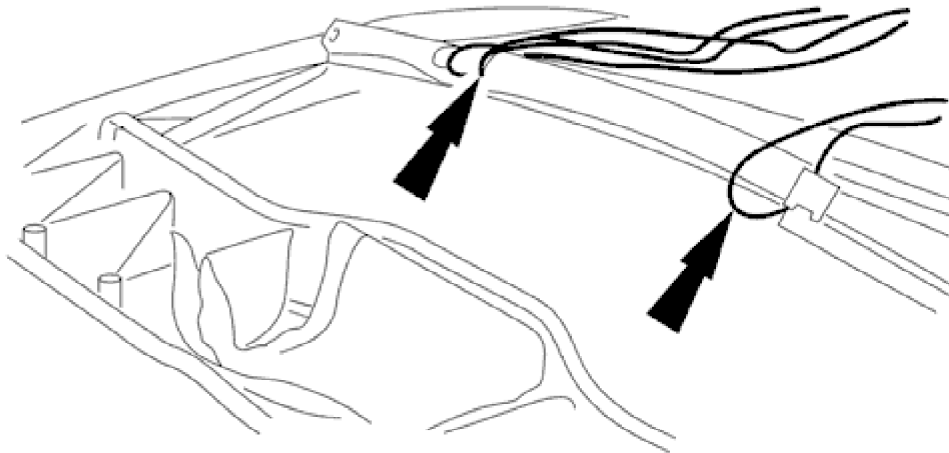

E36166

34. Withdraw the front bow rail from the headlining piping, tension cords and straps.

35. Position tension cords for access.

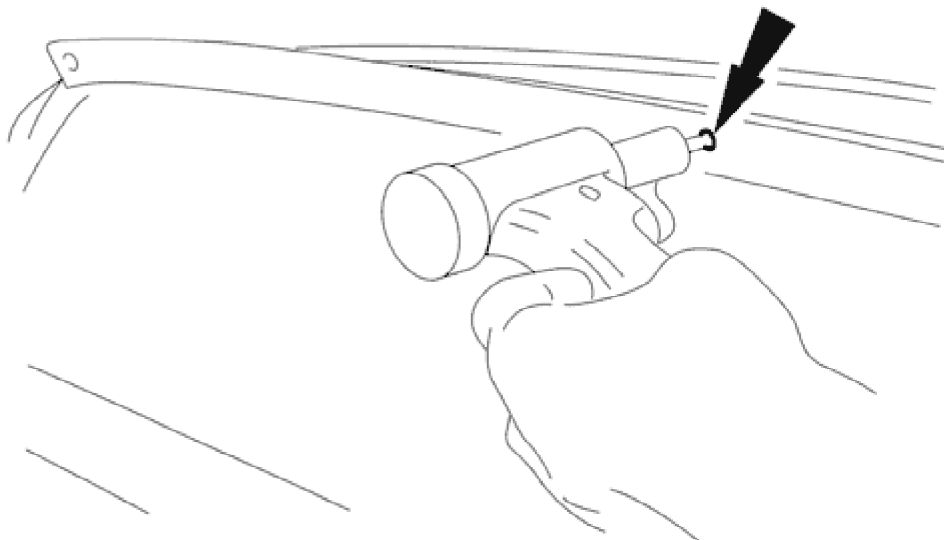

E36167

36. Drill out pop rivets securing centre bow rail to top frame and remove rail from headlining piping.

## 1998 XK RANGE - Convertible Top - 501-18

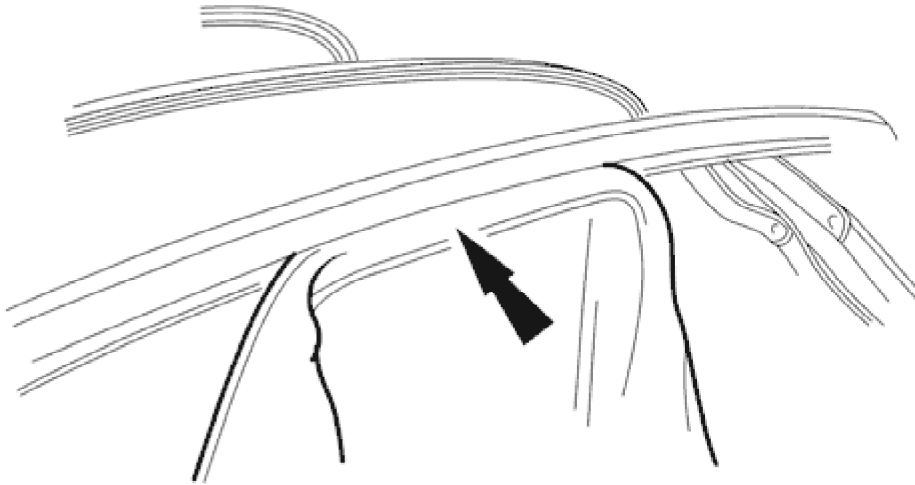

E36168

37. Withdraw headlining rear edge flange from retaining slot in rear bow rail and position rear tension cables for disconnection.

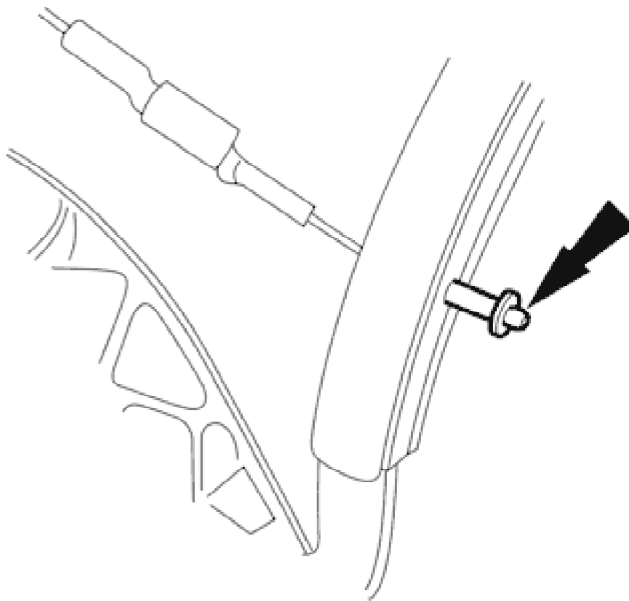

E36169

38. Release and remove tension cable retaining bushes, and disconnect cables from frame.

## 1998 XK RANGE - Convertible Top - 501-18

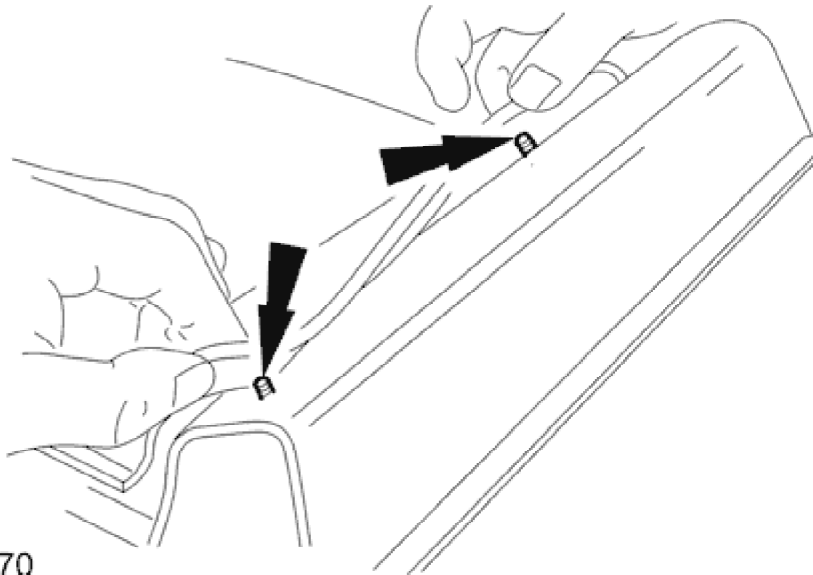

E36170

39. Release headlining fir tree or press stud fasteners from cantrails. Refer to Note in Step 42.

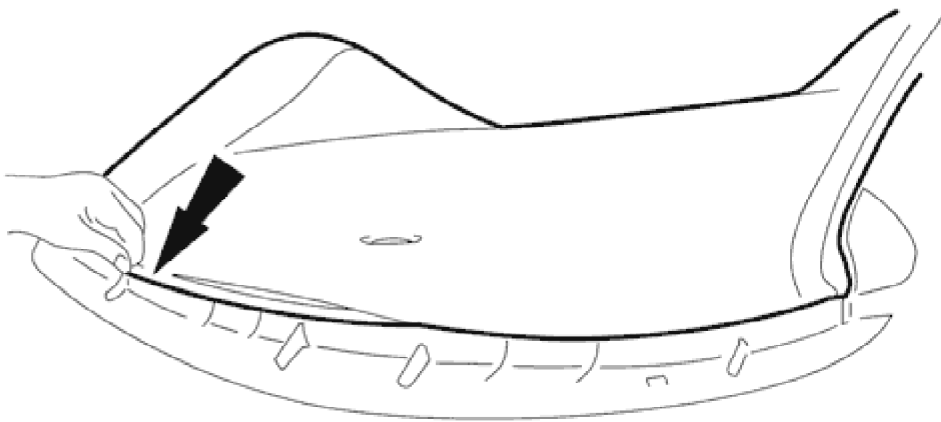

E36171

40. Release front of headlining from double-sided tape on frame.

41. Release the side tension cords and rear tension cables and remove headlining from vehicle.

42. **NOTE:**

On certain early model year vehicles, press-stud fixings securing the the headlining to the frame must be removed and replaced by fir-tree fixings. The procedure for this modification is detailed in Technical Bulletin Number <<501-14>>.

# 1998 XK RANGE - Convertible Top - 501-18

Clean rivet swarf from convertible top area and remove double-sided tape from front of frame.

## Installation

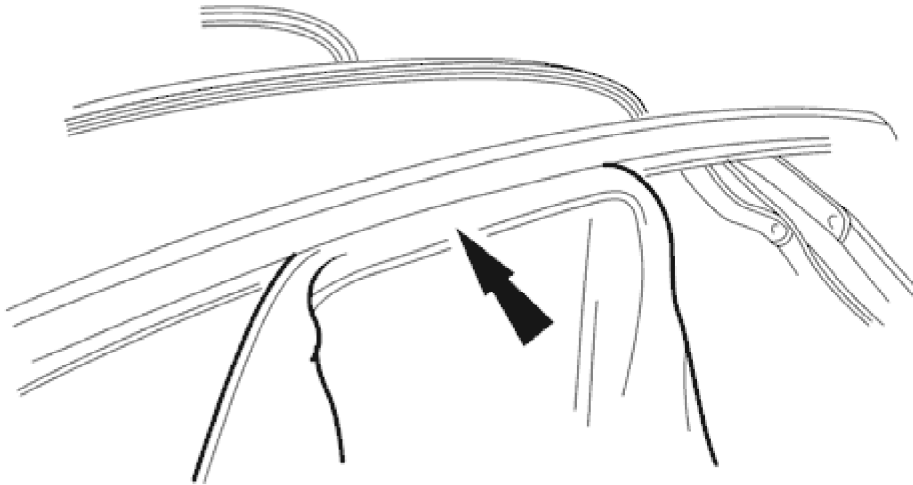

### E36168

1. Place headlining in vehicle, positioning and seating rear of lining in rear bow rail slot.
2. Move padding bag forward for access and check that lining is fully seated on rear bow rail.

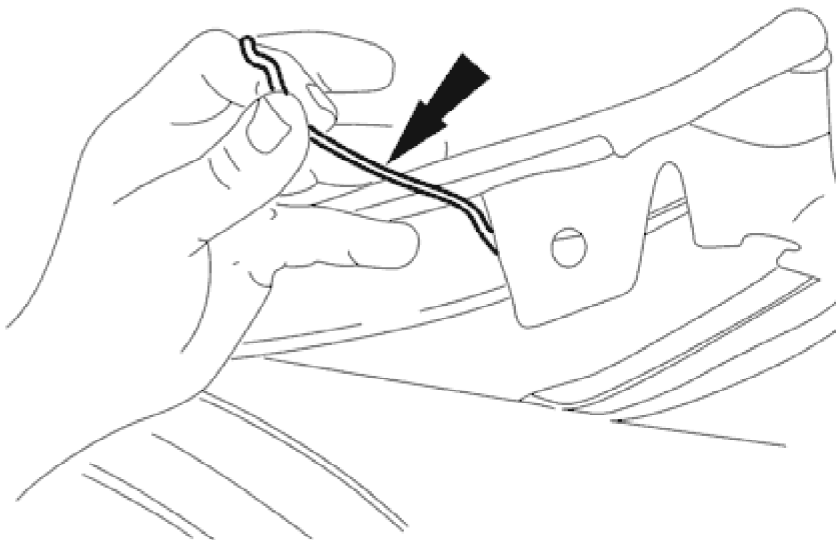

### E36172

3. Route rear tension cables through the headlining piping.

## 1998 XK RANGE - Convertible Top - 501-18

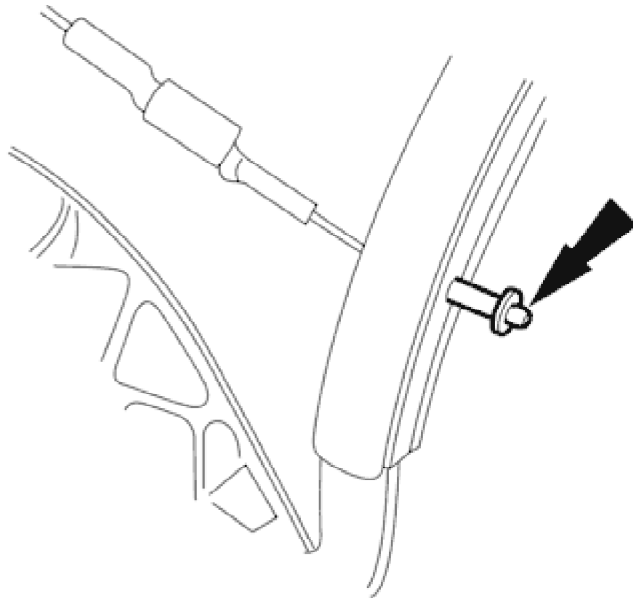

E36169

4. Connect rear tension cables onto frame and fit and fully seat retaining bushes.
5. Move padding bag rearward for access.
6. To prevent damage to headlining during fitting, apply protective tape to leading end of centre bow rail.

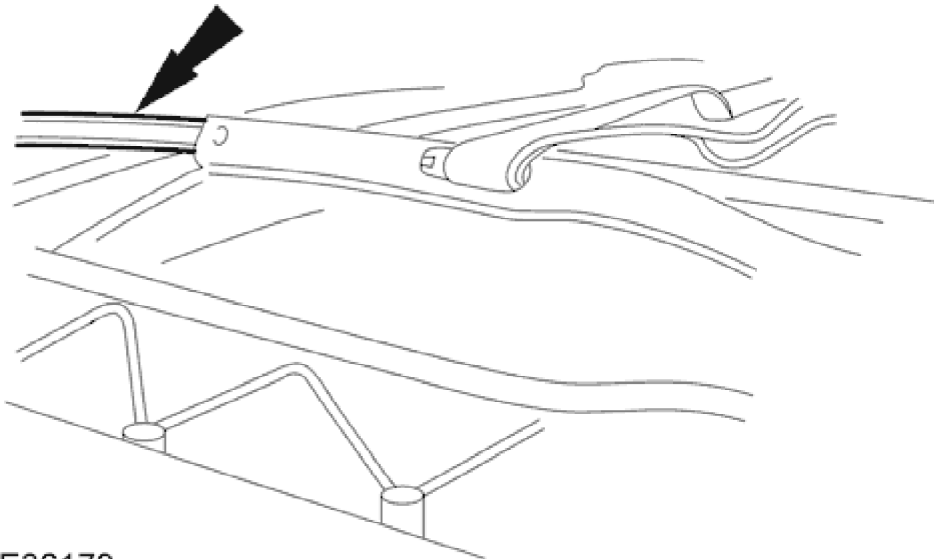

E36173

7. Ensuring correct orientation, feed centre bow rail into the headlining.
8. Manually lower top to halfway position.

## 1998 XK RANGE - Convertible Top - 501-18

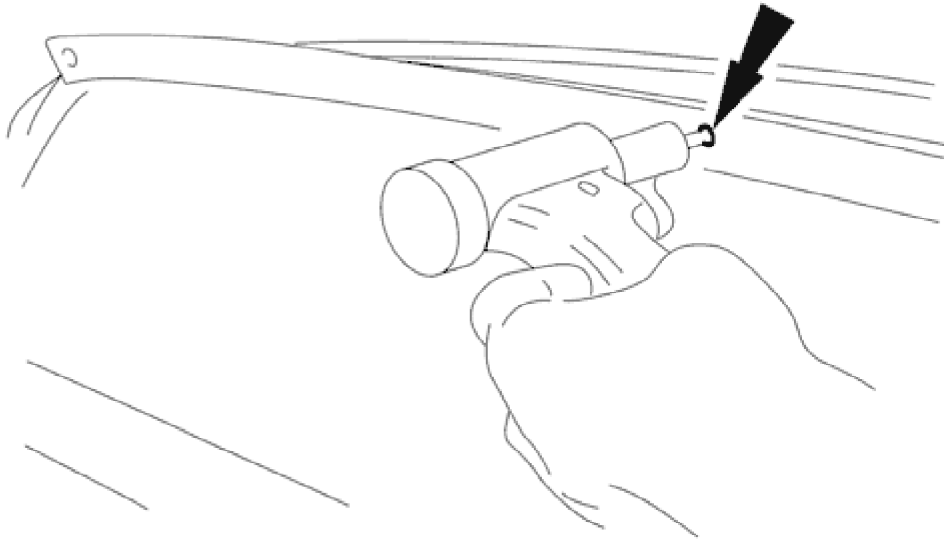

E36167

9. Align bow rail to frame and secure with pop rivets.

10. To prevent damage to headlining during fitting, apply protective tape to leading end of front bow rail.

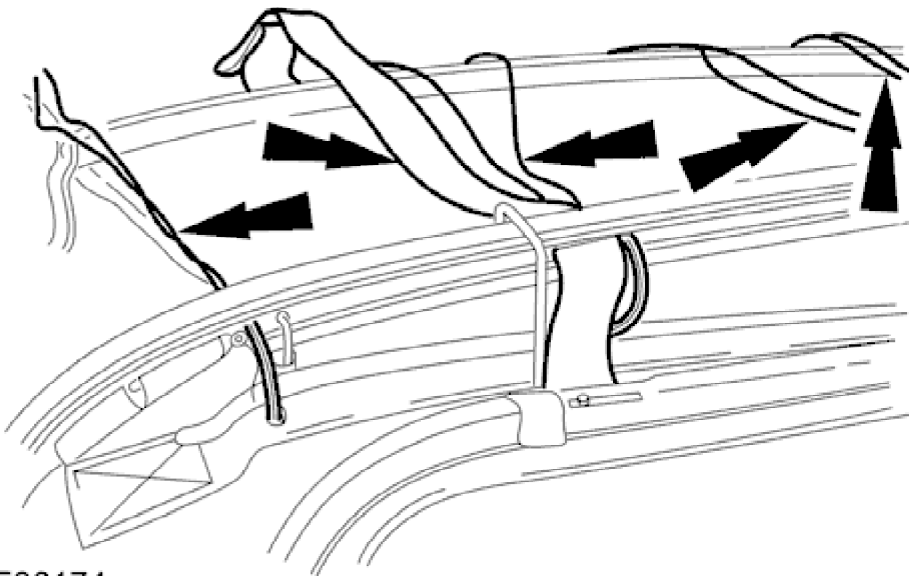

E36174

11. Fit tension cords and straps to front bow rail.

- Cut slits in front bow rail piping to accommodate the tension cords and straps.
- Ensuring that tension cords and straps are not twisted, position them in the appropriate slits in the bow rail piping.

## 1998 XK RANGE - Convertible Top - 501-18

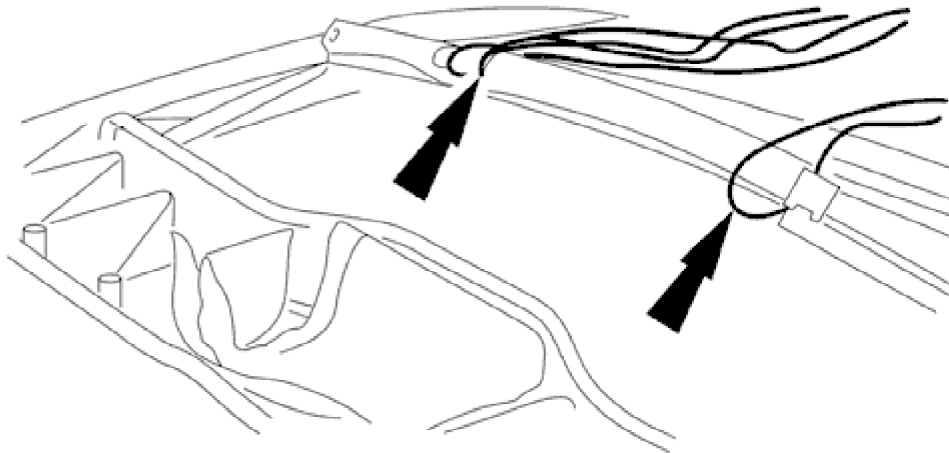

E36166

12. Ensuring correct orientation, feed the front bow rail into the headlining, simultaneously threading tension cords and straps through the piping slits onto the bow rail.

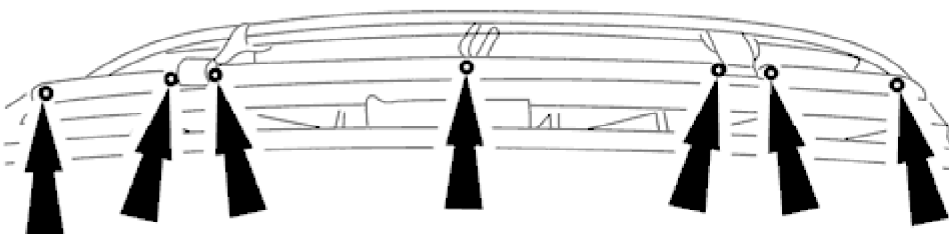

E36165

13. Align front bow rail to frame and secure with pop rivets.



## 1998 XK RANGE - Convertible Top - 501-18

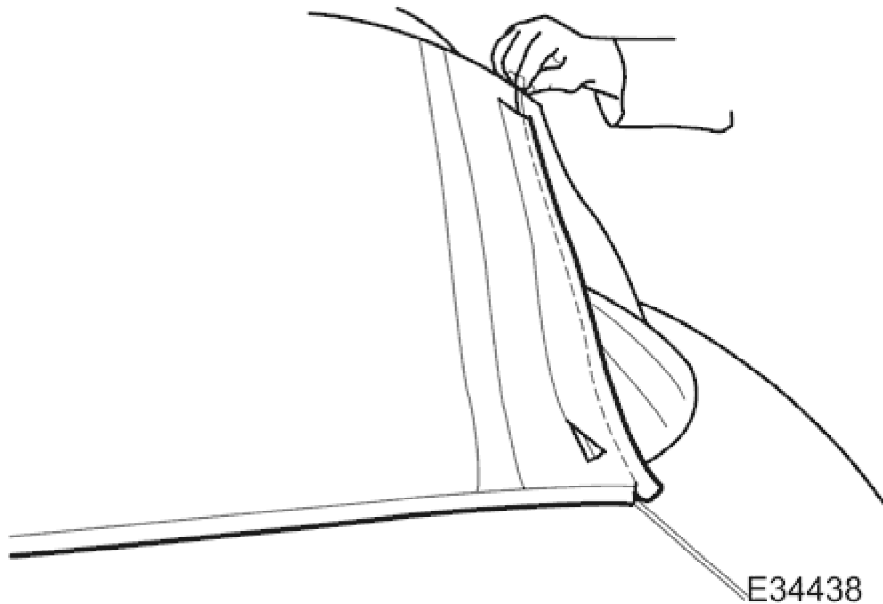

14. Using a piece of welding rod or similar draw wire, pull the outer tension cords through the headlining piping.

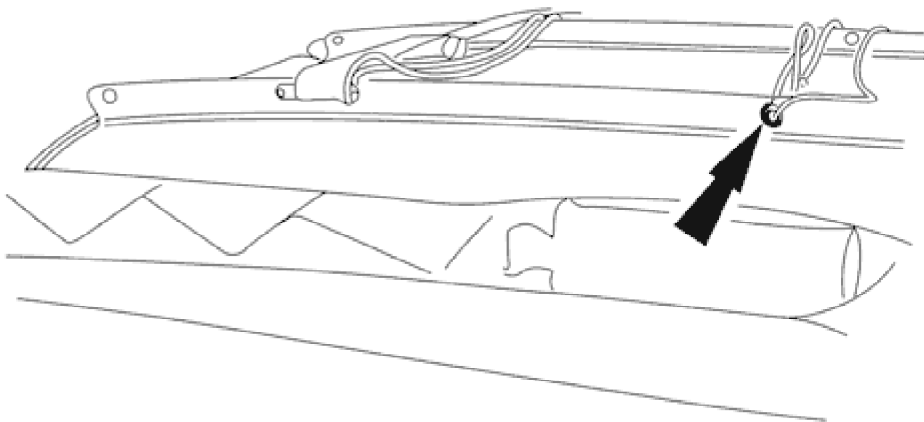

E36164

15. Position the outer tension cords to the frame and secure with pop rivets.

16. Manually move top to fully raised position.

## 1998 XK RANGE - Convertible Top - 501-18

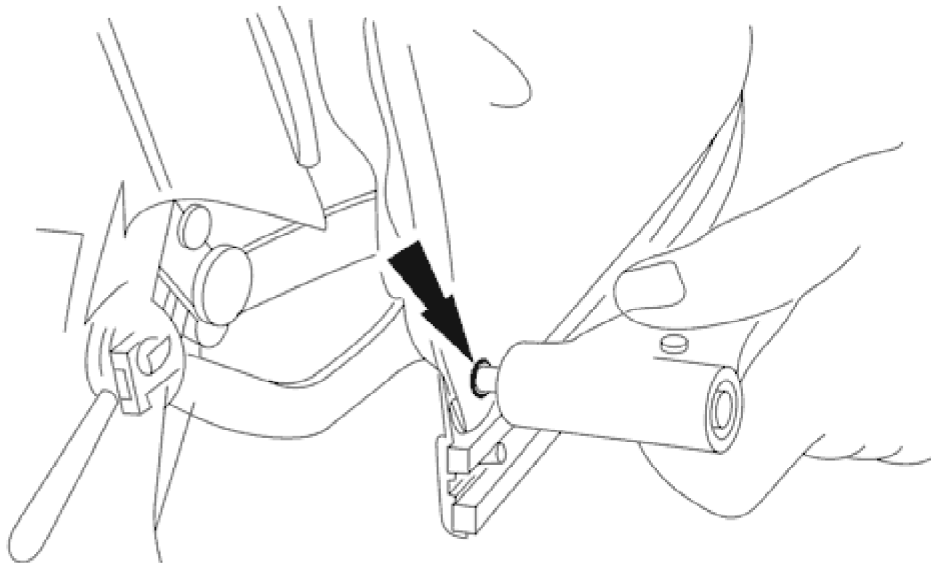

E36175

17. Align rear of headlining, pierce it through existing holes at riveting points in the retaining brackets and pop rivet headlining to retaining brackets.

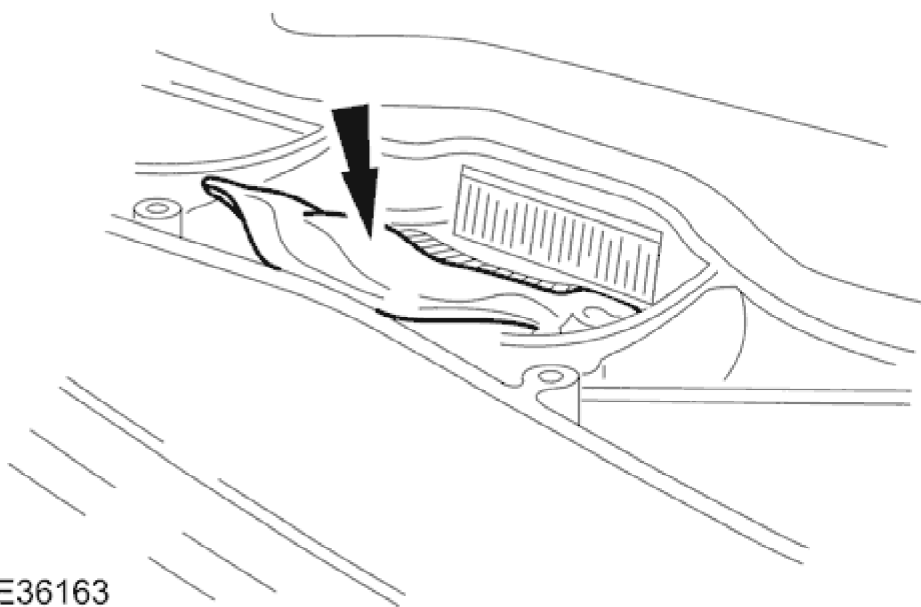

E36163

18. Secure headlining at pull-down handle aperture.

- Remove backing from Velcro strips and position and firmly seat at pull-down handle aperture.
- Feed headlining trim material through frame to pull-down handle aperture and secure on Velcro strips.

## 1998 XK RANGE - Convertible Top - 501-18

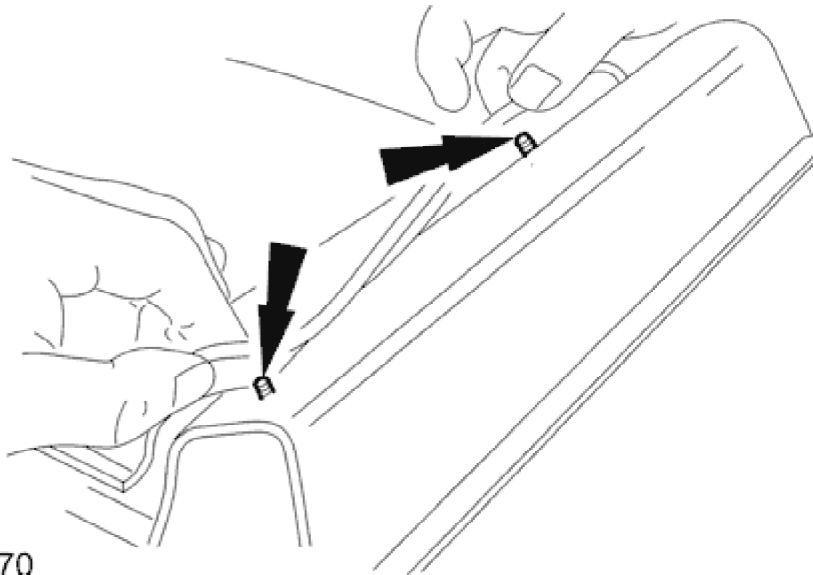

E36170

19. Fit and fully seat new fir tree fasteners securing headlining to frame.

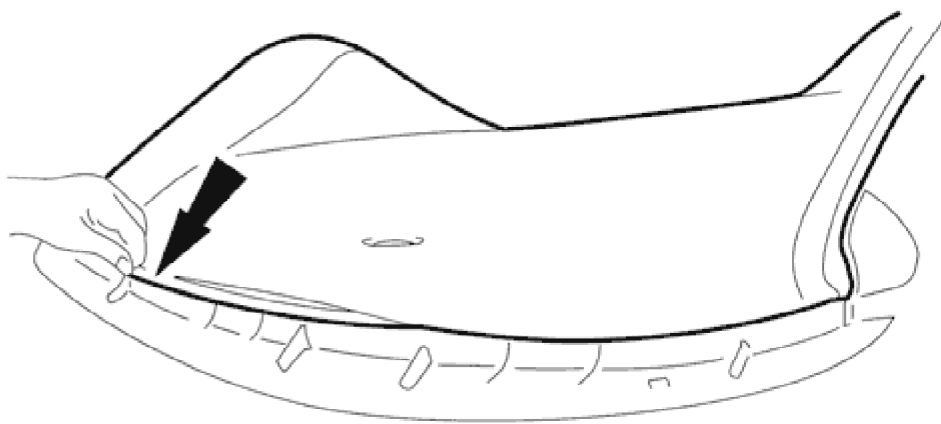

E36171

20. Remove backing from double-sided tape on front of headlining and position and firmly seat lining on frame.

## 1998 XK RANGE - Convertible Top - 501-18

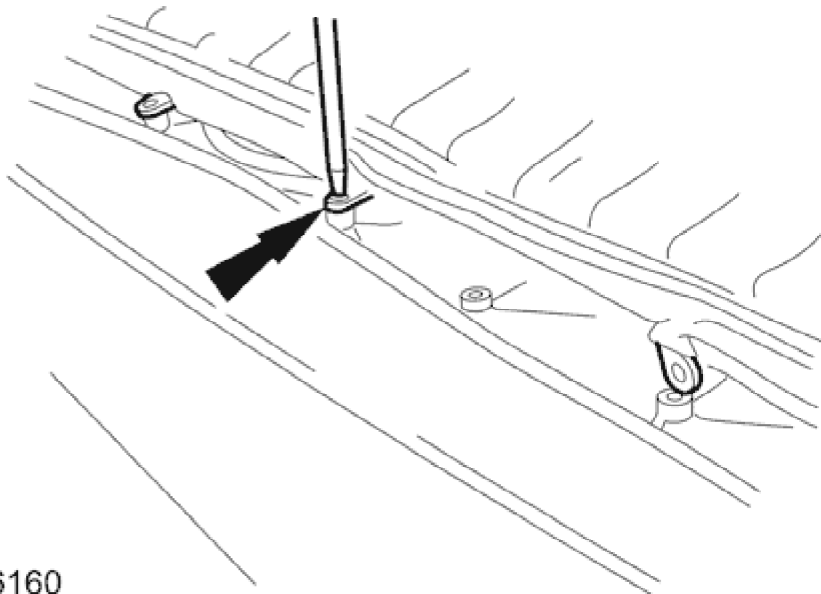

E36160

21. Align padding bag to frame and secure with 'P' clips and retaining screws.

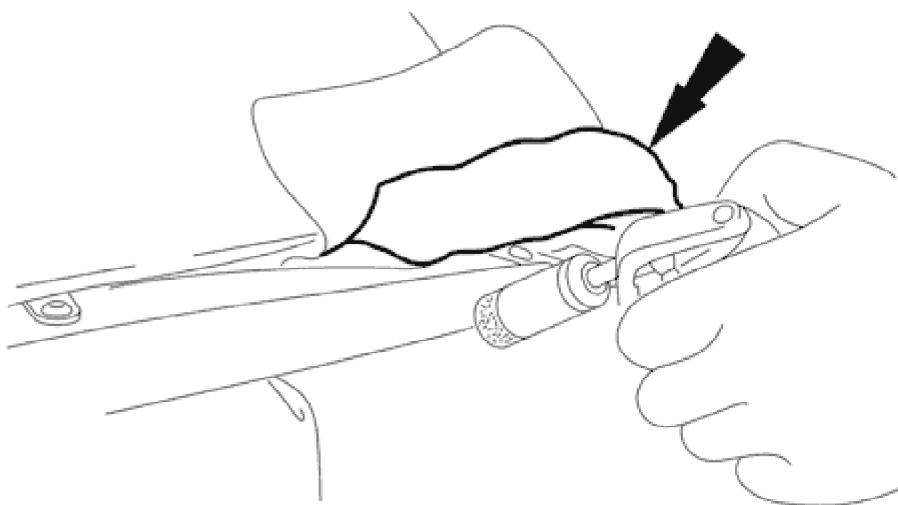

E36176

22. Apply adhesive to front edge of padding bag and position and fully seat on frame.

23. Manually move top to half down position.

# 1998 XK RANGE - Convertible Top - 501-18

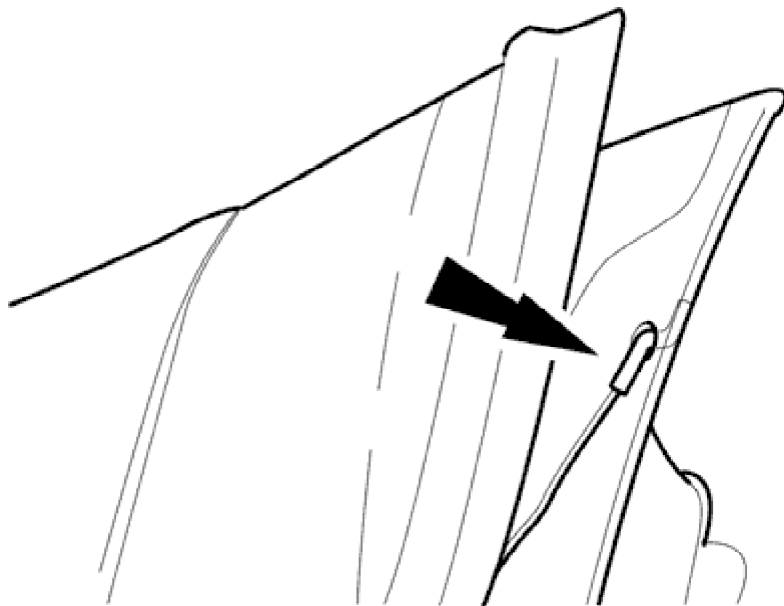

E34452

24. Using a piece of welding rod or similar draw wire, pull side tension cables through outer cover and secure them to frame.

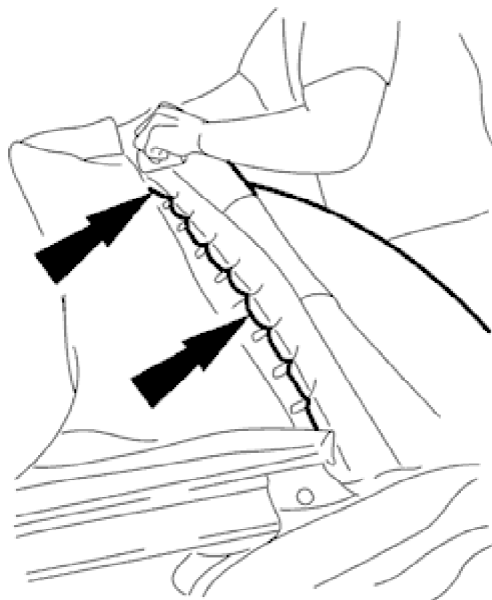

E35699

25. Apply adhesive to adjacent front positions of cover and frame and fully seat cover on frame.

# 1998 XK RANGE - Convertible Top - 501-18

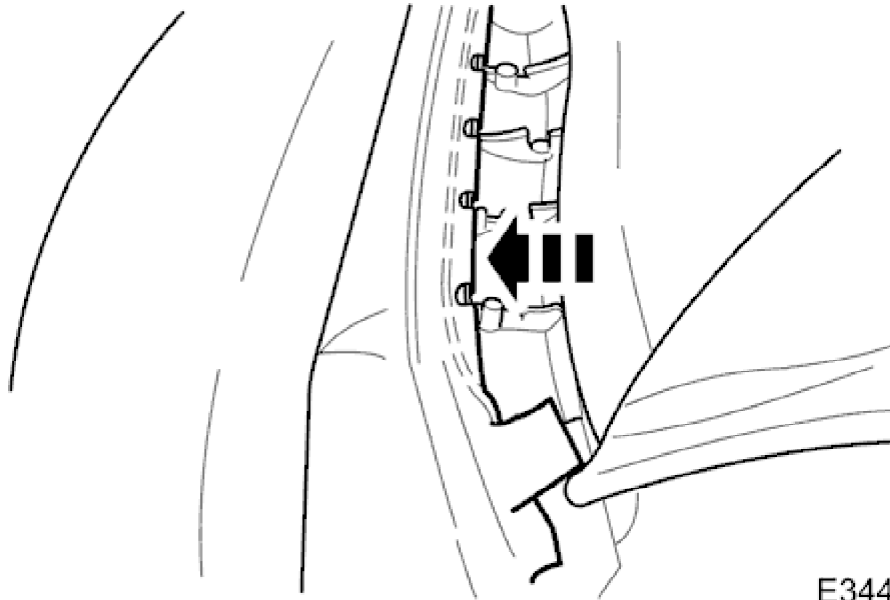

E34432

26. Fit front retaining rod to cover and seat rod in securing clips.

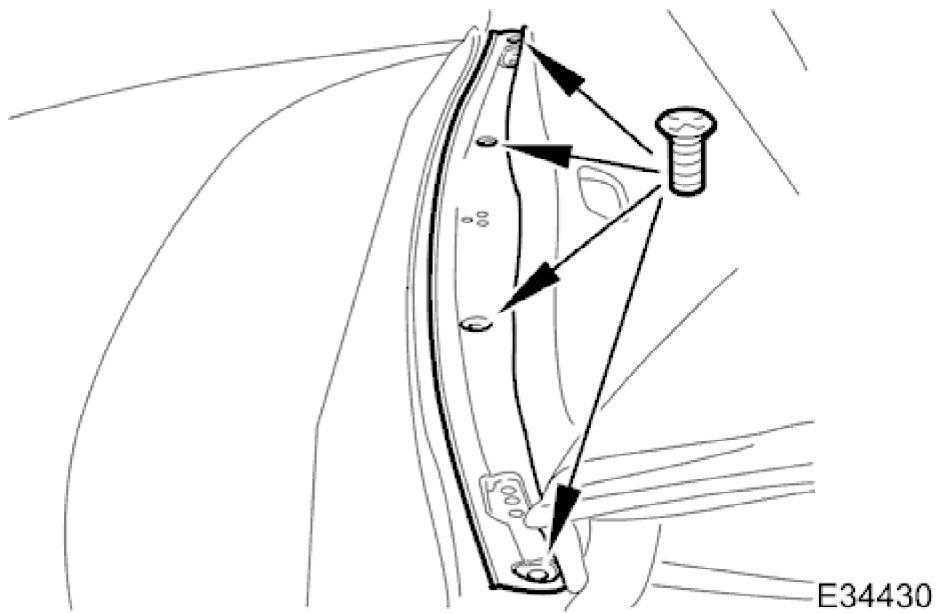

E34430

27. Position latch plate and fit and tighten securing screws.

## 1998 XK RANGE - Convertible Top - 501-18

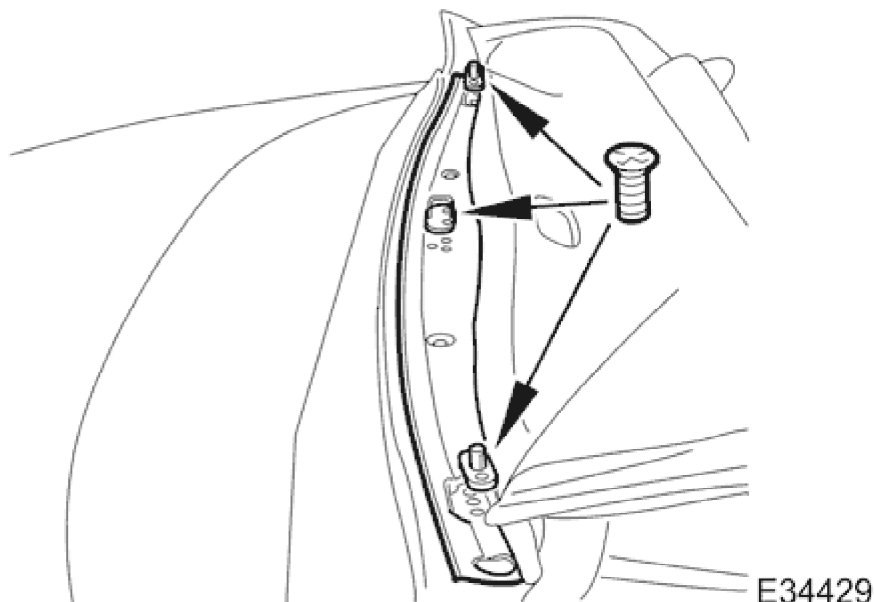

28. Position guide pins and latch strikers and fit and tighten securing screws.

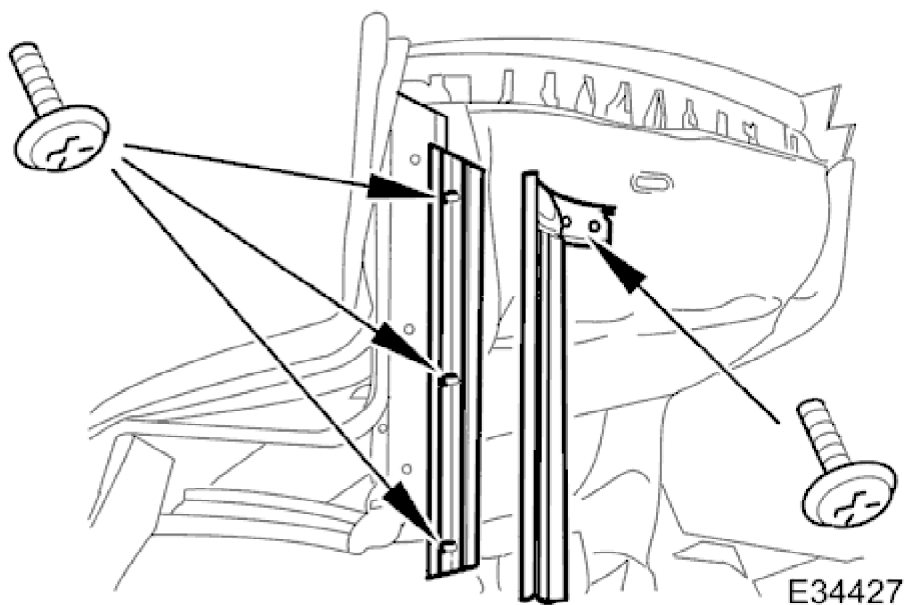

29. Fit cantrail seal carriers.

- Position cantrail seal carriers and fit but do not secure screws.
- Ensuring that seal carriers are positioned towards outboard end of elongated holes, tighten securing screws.

30. Fit and fully seat cantrail seals in carriers and fit and tighten securing screws..

31. Connect ground cable to battery terminal. Refer to <<86.15.15>>.

## 1998 XK RANGE - Convertible Top - 501-18

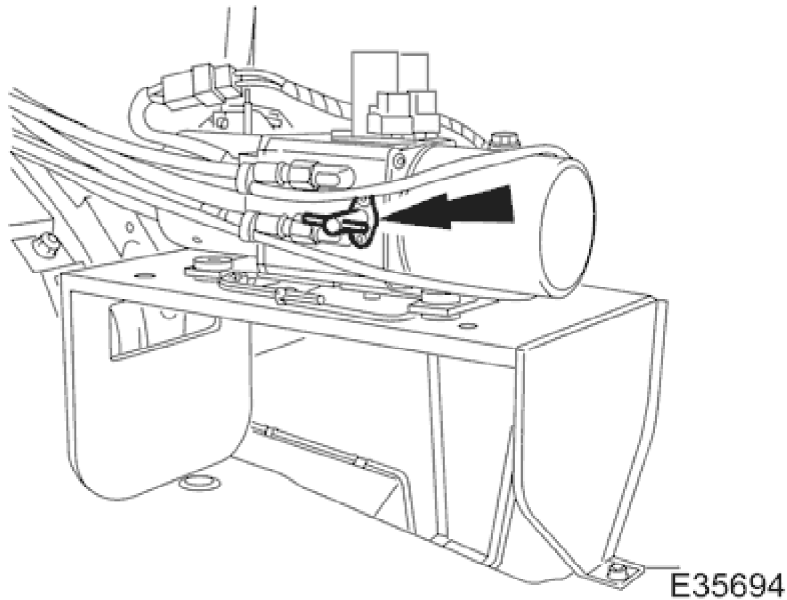

32. Turn hydraulic pump valve fully clockwise to power operation position and return trunk RH liner to correct position.

33. Ensuring that rear quarter lights are fully lowered, power top to fully up and latched position.

34. Apply adhesive to adjacent areas of cover and frame at main column and fully seat cover on frame.

35. Power top to half down position.

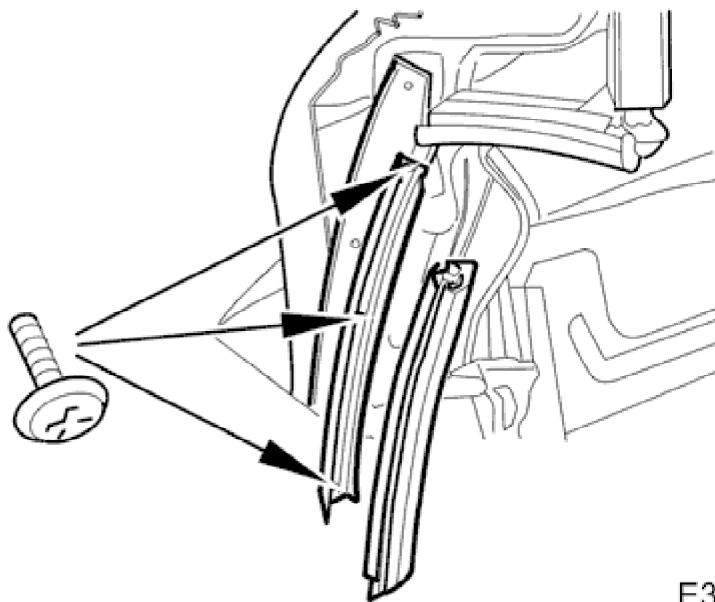

36. Fit main column seal carriers.

- Position main column seal carriers and fit but do not tighten securing screws.
- Ensuring that carriers are positioned towards outboard end of elongated holes, tighten securing screws.



## 1998 XK RANGE - Convertible Top - 501-18

37. Fit and fully seat main column seals in carriers.

38. Power top to fully up and latched position.

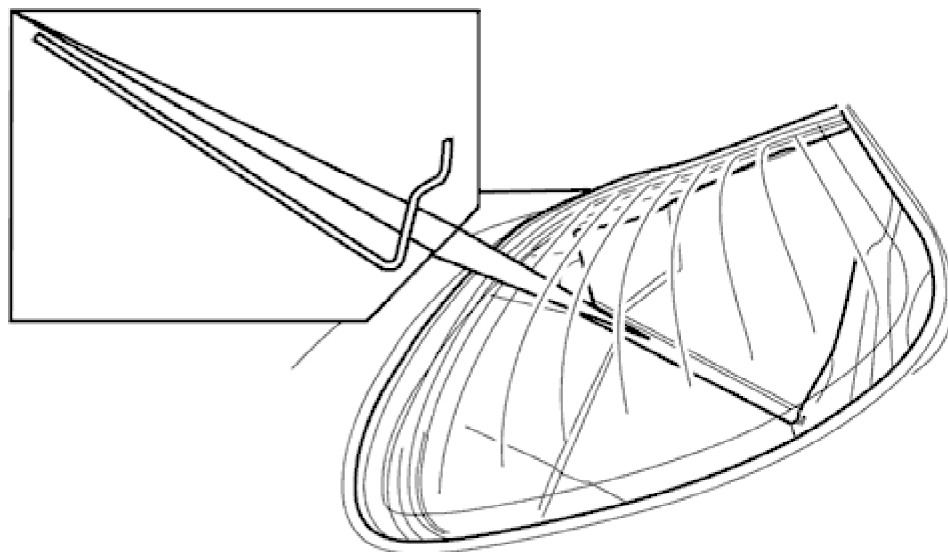

E34433

39. Position headlining and fit and fully seat rear securing rods.

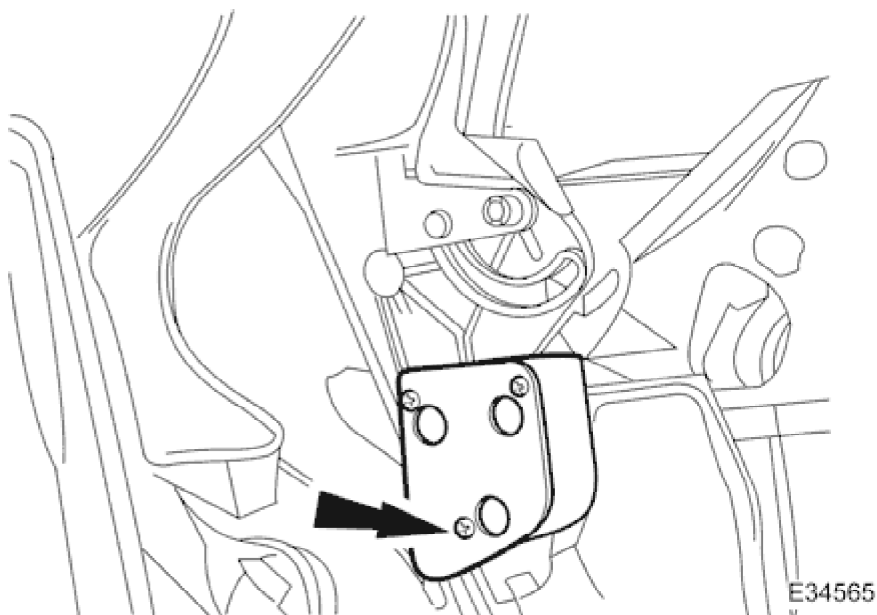

40. Position headlining over cover plates and fit and tighten securing screws.

41. Remove protective tape from BIW.

42. Power top from fully down to fully up positions, checking for satisfactory operation and ensuring that cover

## 1998 XK RANGE - Convertible Top - 501-18

is correctly tensioned and free from rippling.

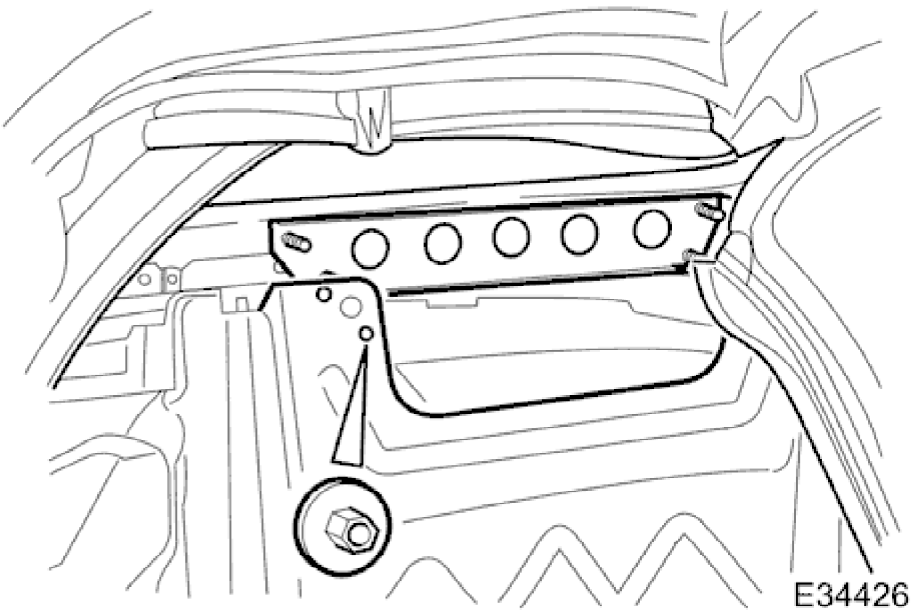

43. Position squab panel stiffener bracket and fit and tighten securing nuts.

44. Fit carpet to convertible top stowage compartment.

45. Fit rear speaker assemblies. Refer to 86.51.06.

46. Fit rear quarter trim panels. Refer to <<76.13.73>>.

47. Fit rear quarter panel cappings. Refer to <<76.13.73>>.

48. Fit rear seat squab. Refer to <<76.70.38>>.

49. Fit rear seat cushion. Refer to <<76.70.37>>.

50. Connect backlight heater harness multiplugs.

51. Fit battery cover.