

Rear Quarter Trim Panel 76.13.73

Removal

1. Remove rear seat cushion and squab. Refer to <<76.70.37>> and <<76.70.38>>.
2. On coupe model, remove coat hanger hook.

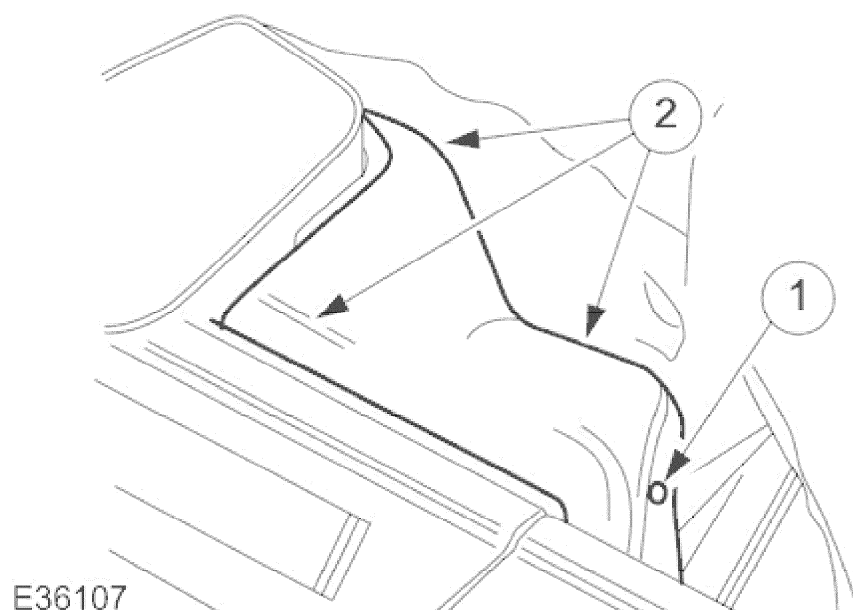

3. On convertible model, remove rear quarter capping.
 1. Remove fastener securing rear quarter capping to 'B' post extension.
 2. Slacken and remove three screws securing the capping, lift capping clear and remove from vehicle.

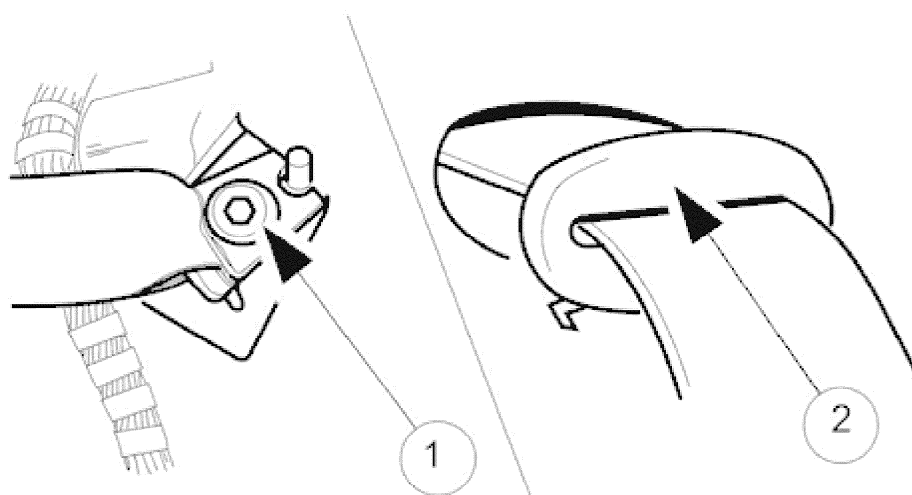

4. On coupe model, detach rear seat belt anchor and remove escutcheon.
 - Slacken and remove rear seat belt anchor plate securing bolt and retain card washer.

1999 XK RANGE - Interior Trim and Ornamentation - 501-05

- Remove rear seat belt escutcheon from rear quarter casing.

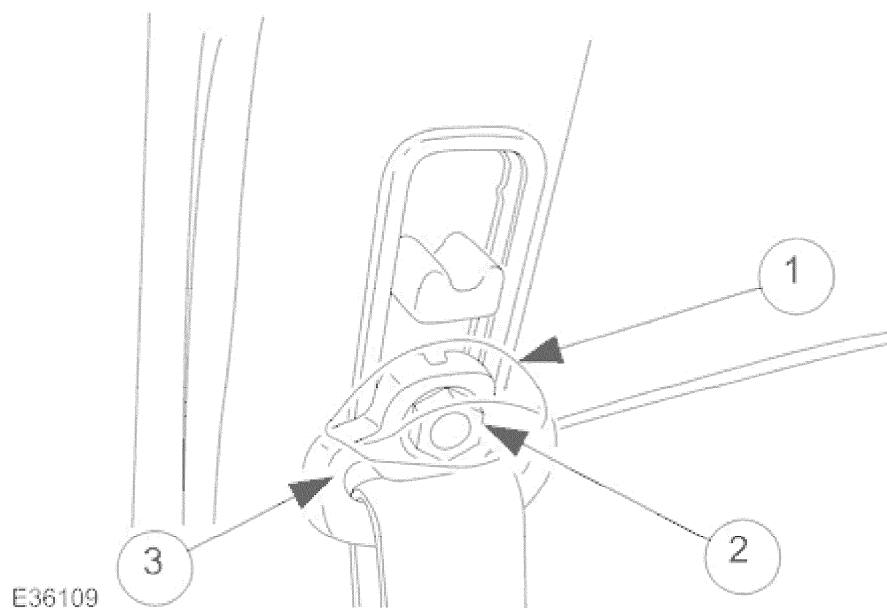

5. Remove front seat belt upper anchor plate and trim.
1. Unclip front seat belt upper anchor plastic cover and position for access to securing nut.
 2. Slacken and remove seat belt upper anchor securing nut.
 3. Remove seat belt upper anchor and plastic cover.

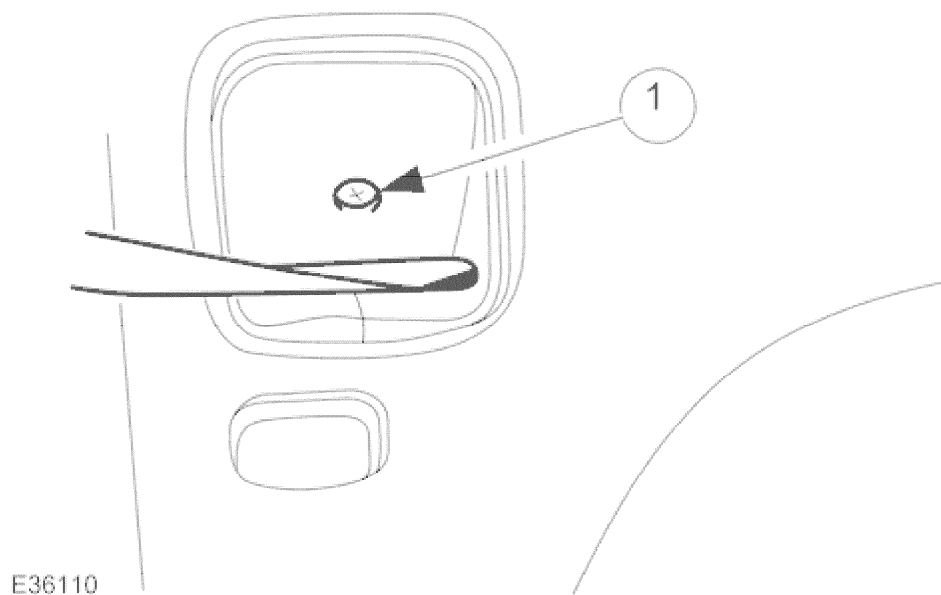

6. Remove front seat belt escutcheon.
1. On coupe model, slacken and remove securing screw from front seat belt upper escutcheon and remove escutcheon from rear quarter casing.

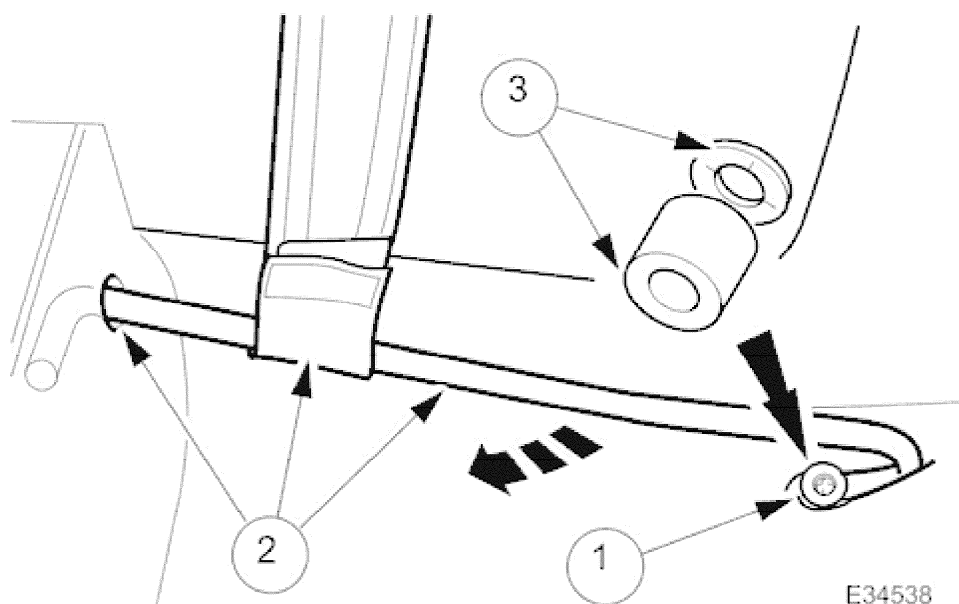

7. Detach front seat belt lower anchor bar.

1. Slacken and remove front seat belt lower anchor bar securing bolt.
2. Remove anchor bar from body grommet and seat belt loop.
3. Retain anchor bar spacer and card washer.

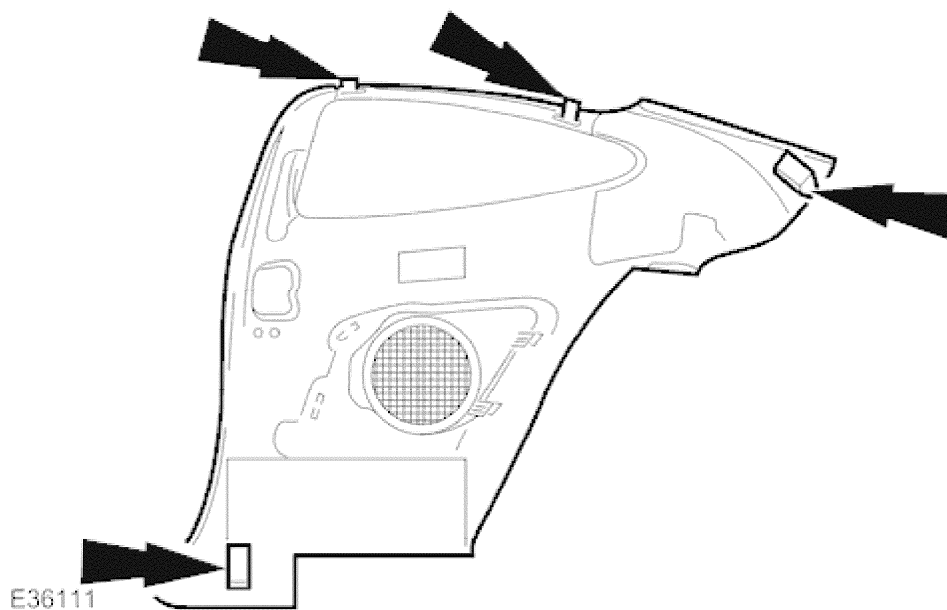

8. On coupe model rear quarter casing, release clips from locations in the cantrail, 'B' post and rear parcel shelf, and position casing for access.

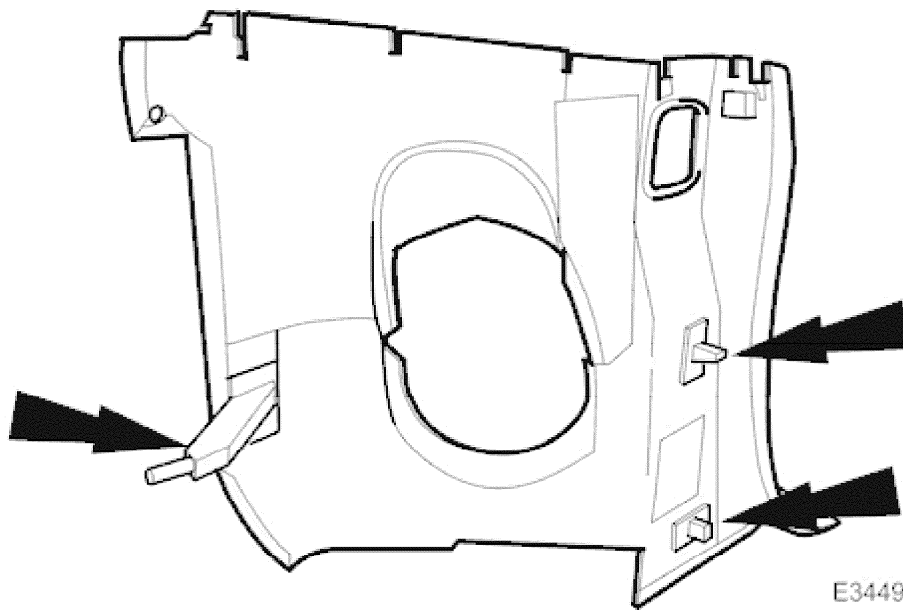

9. On convertible model rear quarter casing, release clips from locations in the 'B' post and two dowels from seat squab panel, and position casing for access.

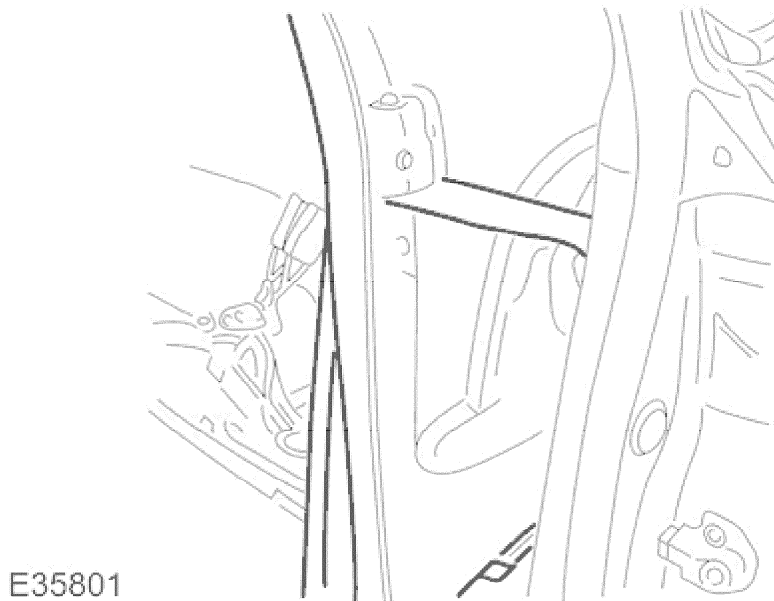

10. Pass seat belt anchor plates through rear quarter casing apertures and remove casing from vehicle.

Installation

1999 XK RANGE - Interior Trim and Ornamentation - 501-05

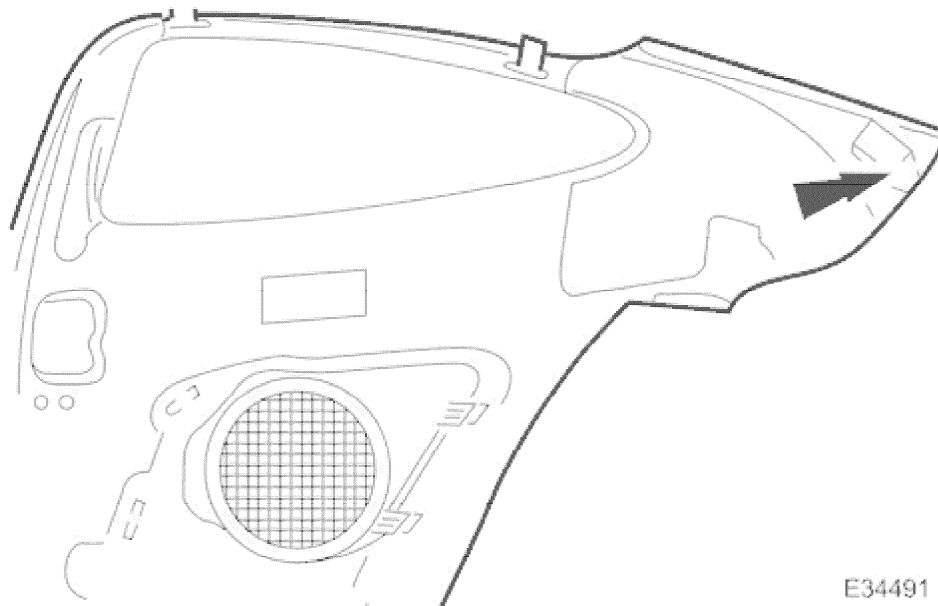

1. On coupe model, position rear quarter casing and engage plastic clip in rear parcel shelf.

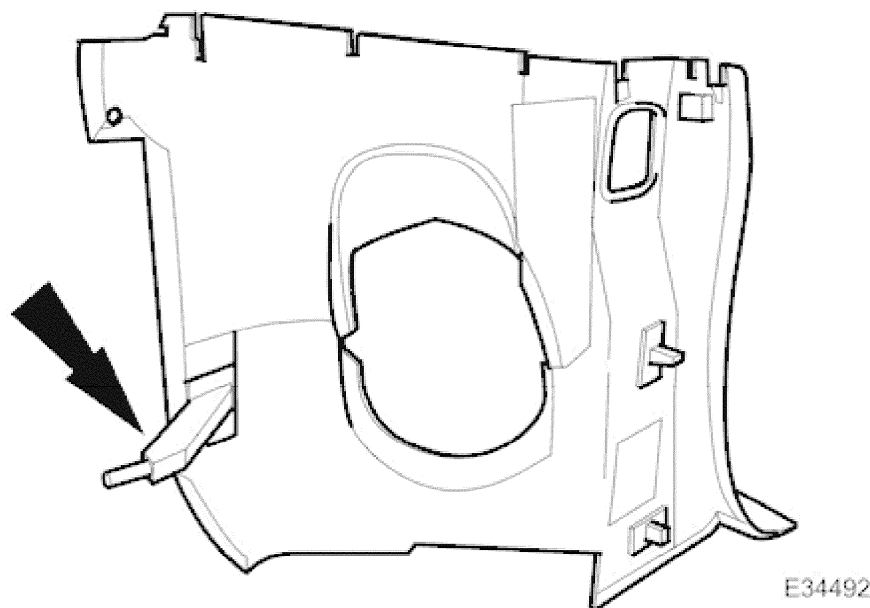

2. On convertible model position rear quarter casing and engage two dowels in rear seat squab panel.

3. Pass seat belt anchor plates through casing apertures.

4. Press home and fully seat the remaining casing clips in body locations.

5. Position and seat front seat belt escutcheon to casing aperture. On coupe model, fit and tighten securing screw.

6. Fit front seat belt anchor bar.

- Pass front seat belt anchor bar through seat belt loop and body grommet.
- Fit securing bolt to seat belt anchor bar.
- Fit spacer and card washer and locate and fully tighten securing bolt.

1999 XK RANGE - Interior Trim and Ornamentation - 501-05

7. Fit front seat belt upper anchor plate.
 - Fit plastic cover to front seat belt upper anchor plate securing stud.
 - Position upper anchor plate on securing stud and fit and tighten securing nut.
 - Fasten upper anchor plastic cover.

8. On coupe model:
 - Fit rear seat belt anchor plate.
 - Fit securing bolt to rear seat belt anchor plate.
 - Fit card washer to securing bolt.
 - Position anchor plate over bolt location and engage and fully tighten securing bolt.
 - Position and seat rear seat belt escutcheon to casing aperture.
 - Fit coat hanger hook.

9. On convertible model, position rear quarter capping, secure to 'B' post extension with fastener and fit and tighten three screws.

10. Fit rear seat squab and cushion. Refer to <<76.70.37>> and <<76.70.38>>.