

Battery Connect



WARNING:

BATTERIES PRODUCE EXPLOSIVE GASES WHICH MAY CAUSE PERSONAL INJURY. DO NOT EXPOSE THE BATTERY TO A NAKED FLAME. WHEN CHARGING OR WORKING NEAR A BATTERY WEAR PROTECTIVE CLOTHING AND EYE PROTECTORS. ALWAYS PROVIDE ADEQUATE VENTILATION. FAILURE TO FOLLOW THESE INSTRUCTIONS MAY RESULT IN PERSONAL INJURY.



WARNING:

BATTERIES CONTAIN SULPHURIC ACID, AVOID CONTACT WITH SKIN, EYES AND CLOTHING. SHIELD YOUR EYES WHEN WORKING NEAR THE BATTERY TO PROTECT AGAINST POSSIBLE CONTACT OF THE ACID SOLUTION. IN CASE OF CONTACT WITH THE SKIN OR EYES, FLUSH IMMEDIATELY FOR A MINIMUM OF 15 MINUTES AND SEEK PROMPT MEDICAL ATTENTION. IF SWALLOWED CALL A PHYSICIAN IMMEDIATELY. FAILURE TO FOLLOW THESE INSTRUCTIONS MAY RESULT IN PERSONAL INJURY.



CAUTION:

Make sure all electrical systems are off before connecting the battery negative cable. Failure to follow these instructions may result in damage to the electrical system.

NOTE:

Following reconnection of the battery, the engine should be allowed to idle as the stored idle and drive values contained within the engine control module (ECM) have been lost. This may cause driveability concern if the following procedure is not carried out.

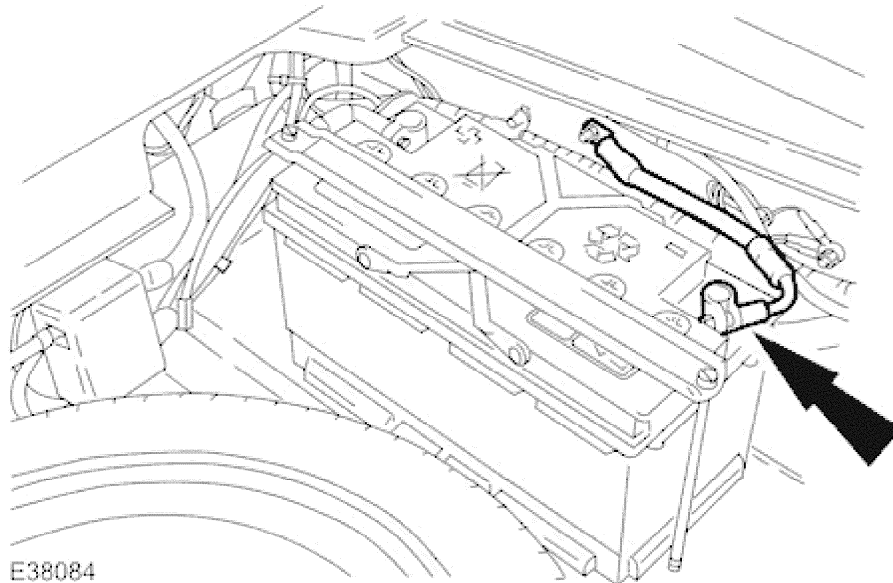

E38084

1. Connect the battery ground cable.
 - Tighten to 4 Nm.
2. Turn the ignition switch to the ON position.
3. Cycle both door drop glasses up and down to establish the upper and lower datum points.
 1. Lower the glass to the stop and hold the switch in the DOWN position for a further five seconds.
 2. Raise the glass fully and hold the switch in the UP position for a further five seconds.
4. Start the engine and allow to idle until the engine reaches normal operating temperature.

2004 XK RANGE - Battery, Mounting and Cables - 414-01

5. Switch the engine off.
6. Start the engine and allow to idle for approximately two minutes (this will allow the ECM to learn the idle values).
7. Apply and hold the brake pedal, select drive and allow the engine to idle for a further two minutes.
8. Drive the vehicle for approximately five miles/eight kilometers of varied driving to enable the ECM to complete its learning strategy.
9. Reset the audio unit, clock and climate control assembly to original settings to avoid customer complaint.