

SERVICE TRAINING COURSE INTR INTRODUCTION TO JAGUAR



ISSUE ONE

DATE OF ISSUE: 10/01/2002

This publication is intended for instructional purposes only. Always refer to the appropriate Jaguar Service publication for specific details and procedures.

All rights reserved. All material contained herein is based on the latest information available at the time of publication. The right is reserved to make changes at any time without notice.



Publication TINTR/02
DATE OF ISSUE: 10/01/2002

© 2002 Jaguar Cars
PRINTED IN USA

ACRONYMS AND ABBREVIATIONS

The following abbreviations and acronyms are used throughout the Jaguar Service Training Student Guides:

A/C	Air Conditioning
A/CCM	Air Conditioning Control Module
APP SENSOR	Accelerator Pedal Position Sensor
APP1	Accelerator Pedal Position Sensor Element 1
APP2	Accelerator Pedal Position Sensor Element 2
AUTO	Automatic Transmission
AWD	All-Wheel Drive
B+	Battery Voltage
BANK 1	RH Cylinder Bank (Cylinders 1, 3, 5, 7)
BANK 2	LH Cylinder Bank (Cylinders 2, 4, 6, 8)
CAN	Controller Area Network
CKP SENSOR	Crankshaft Position Sensor
CM	Control Module
CMP SENSOR / 1	Camshaft Position Sensor / RH Bank
CMP SENSOR / 2	Camshaft Position Sensor / LH Bank
CV	Constant Velocity
D2B	D2B Network
DATC	Dual Automatic Temperature Control
DLC	Data Link Connector
DSC	Dynamic Stability Control
EATC	Electronic Automatic Temperature Control
ECM	Engine Control Module
ECT SENSOR	Engine Coolant Temperature Sensor
EFT SENSOR	Engine Fuel Temperature Sensor
EGR	Exhaust Gas Recirculation
EGT SENSOR	Exhaust Gas Temperature Sensor
EOT SENSOR	Engine Oil Temperature Sensor
EVAP CANISTER CLOSE VALVE	Evaporative Emission Canister Close Valve
EVAP CANISTER PURGE VALVE	Evaporative Emission Canister Purge Valve
FTP SENSOR	Fuel Tank Pressure Sensor
GECM	General Electronic Control Module
GPS	Global Positioning System
HID	High Intensity Discharge
HO2 SENSOR 1 / 1	Heated Oxygen Sensor – RH Bank / Upstream
HO2 SENSOR 1 / 2	Heated Oxygen Sensor – RH Bank / Downstream
HO2 SENSOR 2 / 1	Heated Oxygen Sensor – LH Bank / Upstream
HO2 SENSOR 2 / 2	Heated Oxygen Sensor – LH Bank / Downstream
IAT SENSOR	Intake Air Temperature Sensor
IC	Instrument Cluster
ICE	In-Car Entertainment System
IMT VALVE / 1	Intake Manifold Tuning Valve / Top
IMT VALVE / 2	Intake Manifold Tuning Valve / Bottom
IP SENSOR	Injection Pressure Sensor
KS / 1	Knock Sensor / RH Bank
KS / 2	Knock Sensor / LH Bank
LH	Left Hand
LHD	Left Hand Drive
MAF SENSOR	Mass Air Flow Sensor
MAN	Manual Transmission
MAP SENSOR	Manifold Absolute Pressure Sensor
N/A	Normally Aspirated
NAS	North American Specification
NTC	Negative Temperature Coefficient

NVH	Noise, Vibration and Harshness
OAT	Organic Acid Technology
PATS	Passive Anti-Theft System
PCM	Powertrain Control Module
PTEC	Powertrain Electronic Control
PWM	Pulse Width Modulated
RECM	Rear Electronic Control Module
RH	Right Hand
RHD	Right Hand Drive
ROW	Rest of World
SCP	Standard Corporate Protocol Network
TCM	Transmission Control Module
TP SENSOR	Throttle Position Sensor
TP1	Throttle Position Sensor Element 1
TP2	Throttle Position Sensor Element 2
TURN	Turn Signal
TV	Television
V6	V6 Engine
V8	V8 Engine
VICS	Vehicle Information Control System
VVT VALVE / 1	Variable Valve Timing Valve / Bank 1
VVT VALVE / 2	Variable Valve Timing Valve / Bank 2
WDS	Worldwide Diagnostic System
+ve	Positive
-ve	Negative

INTRODUCTION TO JAGUAR



GENERAL INFORMATION

- 1 INTRODUCTION TO XJ/XK
- 2 INTRODUCTION TO S-TYPE
- 3 INTRODUCTION TO X-TYPE



The illustrations, technical information, data and descriptive text in this publication, to the best of our knowledge, were correct at the time of going to print. The right to change specifications, equipment, procedures and maintenance instructions at any time without notice is reserved as part of our policy of continuous development and improvement

No liability can be accepted for any inaccuracies or omissions in this publication, although every possible care has been taken to make it as complete and accurate as possible.

Jaguar Cars North America Service Training Department

A welcome message to the new Jaguar technician

Introduction to Jaguar is intended not only to provide you with the information you need on an ongoing basis, but also with a historical and cultural perspective of the Jaguar Marque. You might have already noticed a difference between the Jaguar training center and other automotive training centers. The Jaguar training environment is sophisticated yet comfortable so that you will enjoy your stay while you gain important job related skills and knowledge. Jaguar trainers are highly experienced and prepare their classrooms and lesson plans carefully for each class that they teach. You will find that the course presentations and student materials are designed to respect you as a professional, and to adjust to your individual training needs.

I hope the training that you are about to experience begins to express how Jaguar customers and their vehicles need to be treated in your dealership. Of course fixing cars right the first time is important and expected, but Jaguar also offers distinction in the marketplace. The Jaguar difference is that of individual attention to detail, and of treating customers and fellow employees with the utmost respect.

Over the next few days, I ask that you look, listen, learn and participate. If you are not already a Jaguar enthusiast, you soon will be. Welcome to Jaguar.

Regards;



Mike McDonald
Technical and Aftersales Training Manager
Jaguar NA

MILESTONES IN THE HISTORY OF JAGUAR

- 1922 – William Lyons and William Walmsley partner to found the Swallow Sidecar Company

William Lyons



Swallow Sidecar

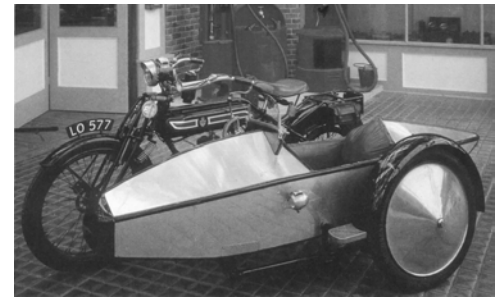

- 1928 – Swallow sedan introduced

- 1935 – SS100 sports car introduced

Swallow Sedan

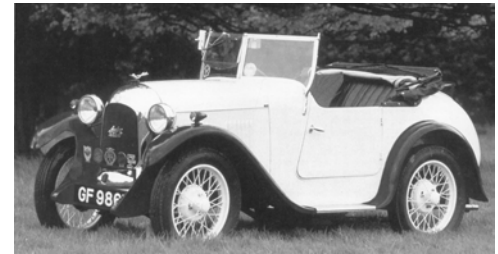

- 1935 – Jaguar name chosen for SS cars

SS100



- 1940-45 – XK engine designed

- 1945 – Company changed name to Jaguar Cars Ltd.

XK120



- 1948 – XK120 introduced

- 1950 – Mark VII sedan introduced

- 1951-1957 – Jaguar wins Le Mans five times

Mk I Sedan

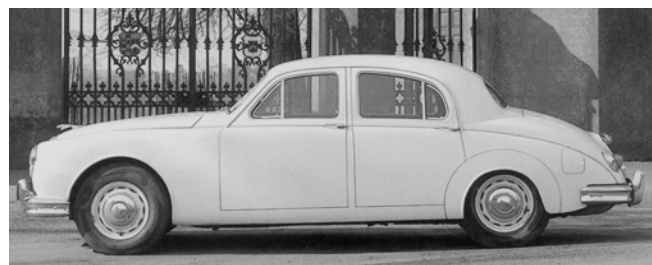

- 1954 – Jaguar Cars of North America opened
-

- 1955 - Mk I Sedan introduced

XK 150



- 1955 - XK140 introduced

- 1957 - XK150 introduced

E-Type



- 1960 - Mk II Sedan introduced

- 1961 - E-type introduced

S-Type



- 1961 - Mark X sedan introduced

- 1964 - 3.8 S-Type introduced

- 1966 - Jaguar merged with British Motors Corporation and later with British Leyland Motor Company

Series I XJ6



- 1967 - 420 sedan introduced

- 1969 - Series I XJ6 sedan introduced

Series III V12 E-Type



- 1971 - 5.3-liter V12 introduced

- 1971 - Series III V12 E-type introduced

- 1972 – Sir William Lyons retired
- 1972 – XJ12 introduced
- 1974 – Series II XJ6 sedan introduced
- 1976 – XJS introduced with 5.3-liter V12 engine
- 1977 – Bob Tullius wins first of two consecutive SCCA Trans Am championships in an XJS
- 1979 – Series III XJ6 sedans introduced
- 1983 – Jaguar becomes independent company as Jaguar Cars Ltd.
- 1985 – Sir William Lyons died
- 1987 – XJ40 (1988 MY) introduced in North America
- 1988 – Jaguar won Le Mans for a sixth time
- 1988 – Jaguar-built XJS convertible (1989 MY) introduced

XJS



SCCA Champions

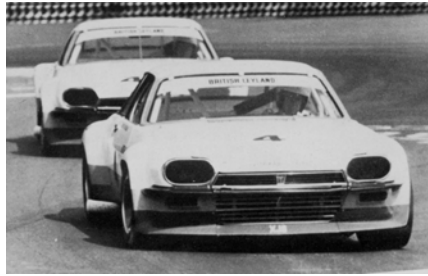

Series III XJ6



XJ40



Le Mans 1988



XJS Convertible



XJ6

- 1989 - Ford buys Jaguar
- 1994 - New range of restyled sedans (1995 MY) introduced including the XJR supercharged sedan



XK8

- 1996 - AJ-V8 engine introduced
- 1996 - XK8 (1997 MY) coupe and convertible introduced



XJ8

- 1997 - XJ8 (1998 MY) introduced
- 1999 - S-Type (2000 MY) introduced



- 2001 - X-Type (2002 MY) introduced
- 2002 - Aston Martin/Jaguar/Land Rover join to form AMJLR

S-Type



X-Type



Jaguar Service Training

The Jaguar Service Training program is designed above all else to increase customer satisfaction by helping the technician to develop the specialized skills and knowledge required to keep Jaguar vehicles operating at peak performance levels.

Professional training is available at five strategically located training centers in North America. Each Jaguar training center provides an ideal learning environment and is equipped to Jaguar dealer standards of appearance, tools, and equipment.

Training Center Locations

California	6 Morgan, Suite 150, Irvine, CA 92718
Canada	8 Indell Lane, Bramalea, Ontario L6T 4H3
Georgia	6160 Peachtree Dunwoody Road, Atlanta, GA 30328
Illinois	1435 Plum Grove Road, Suite A, Schaumburg, IL 60173
New Jersey	555 MacArthur Blvd., Mahwah, NJ. 07430

Jaguar Training Courses

Jaguar Service Training Courses are designed to offer the optimum mix of hands-on with live vehicles and actual components, and the related practical knowledge required to develop a thorough understanding of the vehicle systems. Each course is finely tuned and concisely presented to provide information and develop new skills that technicians can put to work when they return to their dealerships. For a complete listing of current courses and descriptions, refer to Administration Bulletins (section 2 - Training) or visit the Jaguar Business Network (<https://www.jbnonline.com>), Training and Recognition site.

Registering for Training

Jaguar Service Training Schedules are published periodically via Administration Bulletins. Schedules are also available online at the Jaguar Business Network. The schedule shows the class schedules for all five Jaguar Training Centers. There are no geographical restrictions for participating in the training program; dealers anywhere in North America may register their staff at any training center depending on availability. Training seats are allocated to dealerships based on service volume and training gap for initial enrollment. After the initial enrollment period, there are no restrictions and requests are filled on a first come, first served basis.

To register for training, submit the Request for Enrollment, which is included with the published training schedule, to the Training Administrator at Jaguar Cars, Mahwah, NJ via U.S. Mail or fax to (201) 818-9074. State the name and social security number of the enrollee, and the dates, locations, and class titles requested. Jaguar will respond acknowledging receipt of enrollment information. The dealer will be notified that the enrollment is confirmed or that the class is full. If the class is full, the dealer will be offered the choice of alternate dates, alternate locations, or the opportunity to be placed on a waiting list for the originally requested. Jaguar will soon make enrollment and immediate confirmation available online through the Jaguar Business Network.

Multimedia Training

Jaguar supplies each dealership with a series of multimedia training courses on compact discs for use on the Multimedia Training Computer. Available courses include:

- XK8 Introduction
- XJ8 Introduction
- S-Type Introduction (2000 MY)
- S-Type Systems (2000 MY)
- S-Type Introduction (2003 MY)
- Advanced Electrical Circuits and Diagnostics
- Advanced Electrical Components
- PDU Training
- Beginner Electrical

The average time required to complete each course ranges from 1 to 3 hours, depending on the length of the course and student proficiency. Completion of all multimedia courses is a prerequisite for all three levels of recognition in the Service Masters Recognition Program. To receive credit for completing each course, students must complete the course and print the completion certificate. Be sure that the student's name and identification number (SSN or SIN) are printed on the certificate. Then fax or mail the certificate for the attention of:

Training Administrator
Jaguar Cars of North America
555 MacArthur Blvd.
Mahwah, NJ. 07430
Fax: (201) 818-9074

Training Reports

Jaguar dealerships receive a monthly report called the *Training Planner*. The report is a record of all service and parts personnel training completion and required courses. This report may also be available online at the Jaguar Business Network.

Jaguar Technician Qualifications and Training Requirements

To aid in the training and development of technicians, Jaguar has introduced a new Jaguar technician qualification system. This system outlines developmental paths to take the technician from Jaguar Entry Level to Jaguar Expert. In the first phase of the plan, technicians are provided with a knowledge "base". In subsequent years, technicians attend a specific collection of courses to provide them with all the training required to become a Qualified Jaguar Technician in one the four qualification groups. A Jaguar Expert is a technician who has completed all four qualification groups.

Note: *Technician Qualifications stand apart from the Jaguar Masters Recognition Program. For a detailed explanation of the Qualification System, see Administration Bulletin 2-101.*

Jaguar Technician and Qualification Paths

*E = Equivalencies (see bottom of chart)

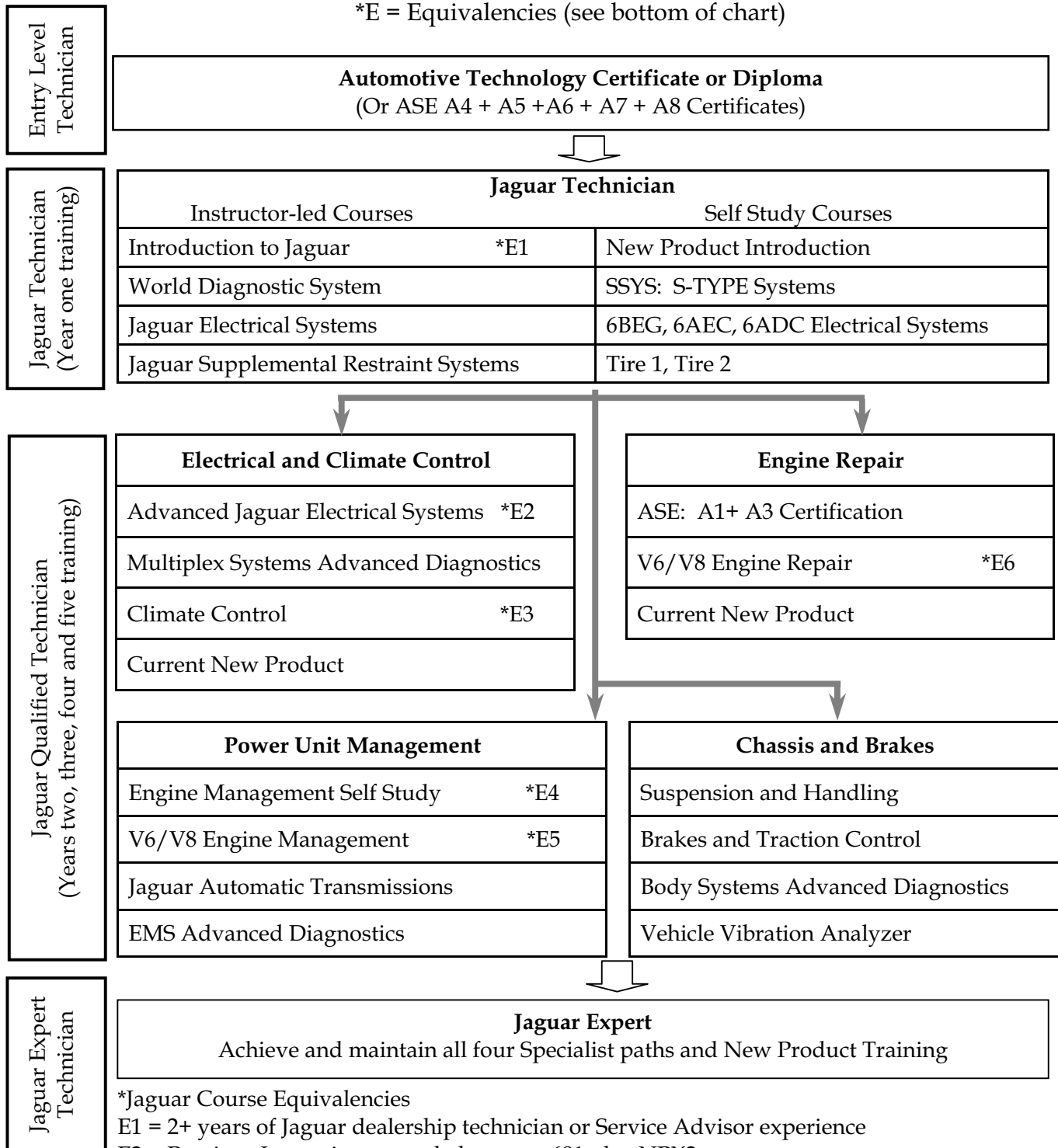

*Jaguar Course Equivalencies

E1 = 2+ years of Jaguar dealership technician or Service Advisor experience

E2 = Previous Jaguar instructor led courses 681 plus NPX2

E3 = Previous Jaguar instructor led courses 701, NP00 and NPX2 (or 702 and NPX2)

E4 = Previous Jaguar instructor led course 801

E5 = Previous Jaguar instructor led courses 880 plus NP00

E6 = Previous Jaguar instructor led courses 180 plus NP00

Technical Hotline

The Jaguar Technical Service Hotline is an important part of the Jaguar commitment to quality. The Hotline provides, at no charge, a direct communications link between the dealership technician and the manufacturer. Its purpose is to give the technician additional assistance to help quickly resolve customer and dealer technical product concerns. It also gives Jaguar "real life" information about service problems that may be occurring within dealerships. Normal hours of operation are from 8am to 7pm Mon.-Fri. EST.

The Technical Service Hotline is for Jaguar technicians employed by authorized Jaguar dealers only. If customers or independent repair shop personnel wish to contact Jaguar, they should call the Jaguar Cars Customer Assistance Center at 1-800-4-JAGUAR (1-800-452-4827) and select option three on their touch-tone telephones.

- The Technical Hotline Precall Work Sheet (S,88) is necessary for repairs that require direct Jaguar assistance.
- Before calling the Hotline to request assistance, the following MUST be performed:
 - Complete the worksheet dealer information and items 1,2 and 3.
 - All applicable Technical Service Manual / JTIS, Service Bulletin, and PDU/WDS diagnostics must be performed.
 - All other applicable service procedures must be performed.
- When you contact the Hotline for assistance, the following must be at hand:
 - The work sheet with dealer information and items 1,2 and 3 completed and documented.
 - All Service Bulletins, Electrical Guides and other publications relevant to the concern.

Technical Hotline Telephone Menu Options

After dialing 1-888-JAG-DLRS (1-888-524-3577) and selecting option two, then select the desired Hotline menu option using the telephone keypad.

Press 1 to close a case

Press 4 for technical support

Press 2 for Multimedia Computer support
for Spanish speaking technical support

Press 5 for a prerecorded technical message
Press 3
Press 8 to repeat all options

NOTE: The Technical Hotline Menu options and selections may be periodically updated without notice. Each time you call; listen carefully to the recorded menu before making a selection.

- Record the Jaguar Cars Technical Representative's recommendations, name, and the CATS case number, if one is assigned.
 - Technical Service Hotline CATS Case Numbers are only given out to dealers who require technical assistance to resolve a concern.
 - A CATS Case Number DOES NOT automatically justify additional warranty paid diagnostic time. It is the dealer's responsibility to properly document all diagnostic and repair procedures on the hard copy of the repair order in accordance with the Jaguar Warranty Policies and Procedures Manual.
- The assigned technician is responsible for follow-up with the Technical Hotline to advise them of case progress.
 - When the problem is rectified, the technician should close the case by calling the Hotline selecting option 1 from the Technical Service Hotline main menu.
- To provide the most effective assistance it may be necessary for the Hotline Technical Representative to work with the technician at the vehicle. In such cases a cordless telephone is an asset.

Technician feedback and input is vital to the Hotline. Please take the time to submit an Electronic Product Quality Report (S,94) on all Hotline case

	<h2 style="margin: 0;">TECHNICAL HOTLINE PRECALL WORK SHEET</h2>	S,88
---	--	-------------

Date of Issue: 3/2000 S,88 page 2 of 2

Dealer _____ Dir. No. _____ Date _____

Person making call _____ Tel. No. _____

VIN

--	--	--	--	--	--	--	--	--	--	--	--	--	--	--	--	--	--	--	--

 Mileage _____

1. Read and follow the instructions on page two of this form BEFORE calling the Jaguar Technical Service Hotline.
2. Fill in the following information.

PROBLEM DESCRIPTION (include all DTCs and any other relevant information): _____

PREVIOUS REPAIRS, CASES AND / OR DIAGNOSIS: _____

3. Call the Hotline and discuss the problem with the Hotline Representative.
 Telephone: 1-888-JAG-DLRS (1-888-524- 3577)
 FAX: (201) 818-8478
 Refer to page 1 for MENU OPTIONS.

4. Record the Hotline recommendations.

HOTLINE RECOMMENDATIONS: _____

Jaguar Tech. Rep. _____ CATS Case No.

NOTE: A Technical Service Hotline CATS Case Number is only assigned to vehicles when the dealer requires special technical assistance to resolve a concern. The assignment of a CATS Case Number DOES NOT automatically justify additional warranty paid diagnostic time. It is the dealer's responsibility to properly document all diagnostic and repair procedures on the hard copy of the repair order in accordance with the Jaguar Warranty Policies and Procedures Manual.

Field Service Engineer

Jaguar provides on-site technical assistance through Field Service Engineers. Each FSE is “home based” and serves two market areas. FSE’s are responsible for preventing reacquired vehicles by providing technical assistance in cases where in-dealer resources have been exhausted and the Technical Hotline has been unable to assist in resolving the vehicle fault. In addition to the Technical Hotline, FSE’s also have access and support of Product Investigation and Engineering. FSE’s also make routine visits to all the dealers within their markets. During these visits, they will analyze operational procedures utilized by service departments and offer recommendations, which will improve “fix right first time” scores. When FSE assistance is required, the dealer’s Aftersales Market Manager (AMM), Service Manager, or Technical Hotline can initiate the visit.

Jaguar Masters Recognition Program

Jaguar recognizes the accomplishments of service technicians through the Technicians Association of the Jaguar Masters Recognition Program. Technicians have the opportunity to achieve recognition at three levels in the Technicians Association:

- Certified
- Associate
- Master

Top scoring Master Technicians are invited to compete in a hands on technical competition that determines Guild Status. In addition to being named Guild Member, the top-scoring technician in the competition is named the Brian Fuerstenau Winner. This technician is honored at a special award presentation at his or her dealership.

The requirements for each level are based on Jaguar dealership technical experience, ASE certifications, training, and passing the TechExam, an open book technical exam for technicians. The minimum requirements for each of the three levels are detailed in the Jaguar Masters Recognition Program binder or online. To see the requirements online, visit the Training and Recognition Section of Jaguar Business Network online.

Jaguar Customer Satisfaction Index (JCSI)

In the highly competitive luxury car market, Jaguar continuously seeks to maintain and improve customer satisfaction. Customer feedback is vital for identifying the strengths and weaknesses of dealership and manufacturer performance. Jaguar acquires service department performance through surveys.

What does JCSI measure?

- Customer satisfaction
- Effectiveness of retail process
- Dealer diagnostics that improve customer handling
- Indications of how well we are building and sustaining our evolving relationships with customers

Jaguar Owners

Jaguar cars appeal to a distinctive group of people; independent, highly successful individuals who have achieved a substantial measure of professional and personal accomplishment. They appreciate the refined elegance and performance of the product and expect competent professional service and courteous personal treatment. Jaguar owners expect perfection in their cars and in service from their Jaguar dealer.

JAGUAR DEMOGRAPHICS U.S. MARKET

		XJ	XK	S-TYPE	X-TYPE	Select Edition
Target	Age	Adults 45-54	Adults 45-54	Adults 35-54	Adults 30-39	Adults 35-54
	Income	200+ HHI	200+ HHI	100+ HHI	75+ HHI	150+ HHI
	Gender	50/50 Male/Female	65/35 Male/Female	50/50 Male/Female	40/60 Male/Female	60/40 Male/Female
Media	Age	Adults 35-54	Adults 35-54	Adults 35-54	Adults 30-49	Adults 35-54
	Income	100+ HHI	100+ HHI	75+ HHI	75+ HHI	100+ HHI
	Gender	50/50 Male/Female	65/35 Male/Female	50/50 Male/Female	40/60 Male/Female	60/40 Male/Female
Actual	Age	Adults 53	Adults 52	Adults 53	Adults 52	Adults 53
	Income	215 HHI	289 HHI	50% 100+ HHI	128 HHI	138 HHI
	Gender	61/39 Male/Female	68/32 Male/Female	51/49 Male/Female	57/43 Male/Female	65/35 Male/Female
		Based on XJ8		Sourced: NOP Automotive Phone Surveys		

JCSI Survey Process Overview

A customer has a dealership experience (new car/pre-owned purchasers/lessees, and warranty). A telephone call (proactive customer contact (PCC)) is made to the customer within seven days to assess overall satisfaction. The customer's satisfaction or dissatisfaction is posted on the Performance Metrics Website allowing dealership personnel to "recover" a customer from a negative experience.

Paper Reports

The JCSI report summarizes the JCSI overall index, sales index, service index, and PCC/Mail survey sample dispositions.

- Produced monthly, summarizing current month, previous 11 months and 12-month averages for the sales and service mail survey.
- Provides trends, graphs, and tables to make it easy to track dealership performance.
- Displays dealership's national rank based on a 12-month rolling average. (Note: dealership must have a minimum of 30 returns for the 12-month period to be ranked; "N/A" will appear instead of a value if this is not the case.)

Displayed are the dealer, district, and national scores for overall JCSI index, sales index, and service index.

Electronic Reports

Survey information is updated daily and is available on the web through Jaguar Business Network (JBN) online.

Site Access

- Log on to the secure Jaguar Business Network (JBN) online system using your unique user ID and password (<https://jbnonline.com>)
- Double-click on the "Jaguar Performance Metrics" link

Web Information

- JBN features real-time data. Reports are updated throughout the day as contacts are completed and mail surveys returned are processed
- User-friendly system
- Menu-driven, drill-down capacity

Ability to view individual customer responses (No other dealership will be able to access or acquire your reports. The information is protected by log-in and password procedures).

Dealer XYZ
 Dealer Code: 9999
 April Activity Report

JCSI 2000



Overall JCSI Index (Current Month)

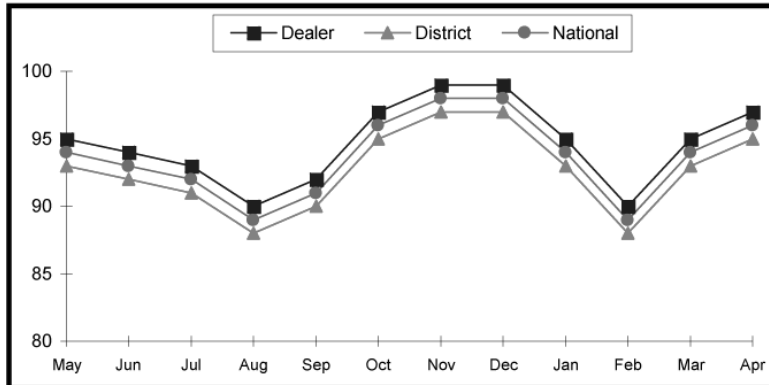

Overall JCSI National Rank: 10 of 139

	Dealer	District	National
May	95	93	94
June	94	92	93
July	93	91	92
August	90	88	89
September	92	90	91
October	97	95	96
November	99	97	98
December	99	97	98
January	95	93	94
February	90	88	89
March	95	93	94
April	97	95	96
12 mo. avg.	95	93	94

JCSI Sales Index (Current Month)

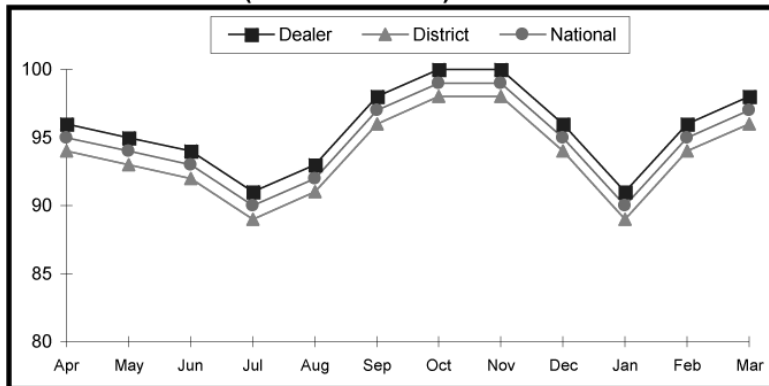

	Dealer	District	National
May	96	94	95
June	95	93	94
July	94	92	93
August	91	89	90
September	93	91	92
October	98	96	97
November	100	98	99
December	100	98	99
January	96	94	95
February	91	89	90
March	96	94	95
April	98	96	97
12 mo. avg.	96	94	95

JCSI Service Index (Current Month)

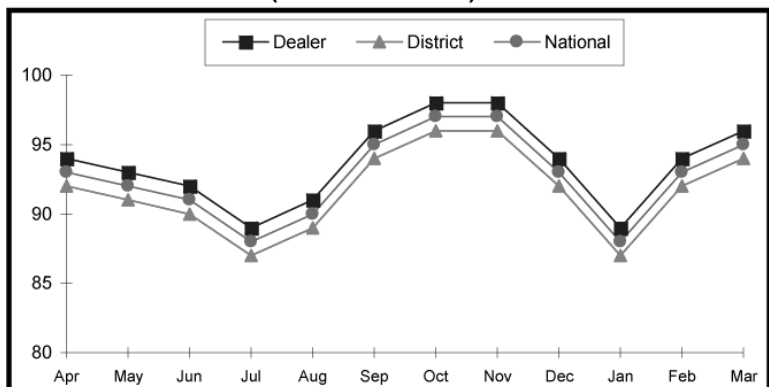

	Dealer	District	National
May	94	92	93
June	93	91	92
July	92	90	91
August	89	87	88
September	91	89	90
October	96	94	95
November	98	96	97
December	98	96	97
January	94	92	93
February	89	87	88
March	94	92	93
April	96	94	95
12 mo. avg.	94	92	93

	PCC Sample Disposition										
	Records Received	Valid Phone	% Valid Dealer	% Valid National	Completed Interviews	% Complete Dealer	% Complete National	% Complete Dissatisfied	% Dissatisfied Dealer	% Dissatisfied National	+/- Variance
Sales RDR's	100	80	80%	81%	40	40%	42%	4	10%	11%	1%
Service Warranty	80	75	94%	90%	40	50%	40%	8	10%	11%	-1%
Pre-Owned RDR's	100	90	90%	90%	40	40%	41%	10	10%	10%	-

	Postal Survey Sample Disposition							+/- Variance	Undeliverable
	Records Received	Surveys Mailed	% Mailed Dealer	% Mailed National	Surveys Returned	% Returned Dealer	% Returned National		
Sales RDR's	100	80	80%	81%	40	40%	45%	-5%	5%
Service Warranty	80	75	94%	90%	40	50%	55%	-5%	7%
Pre-Owned RDR's	100	90	90%	90%	40	40%	45%	-5%	8

Electrical Guides

Electrical schematics and associated information are contained in Electrical Guides. Electrical Guides are available in print and electronic (JTIS) versions. Electrical Guides are specific to individual models and, in most cases, individual model years.

Electrical Guide Format

All current Jaguar Electrical Guides are made up of two major sections. The first section, at the front of the guide, provides general information for and about the use of the guide, and information and illustrations to aid in the understanding of the vehicle electrical/electronic systems, as well as location and identification of components. It is **STRONGLY** recommended that technicians read thoroughly through this section of the guide to develop familiarity with the layout and use of the guide.

The second section includes figures (wiring diagrams), which are the basis of each Electrical Guide. Each Figure is identified by a Figure Number (i.e. Fig. 01.1) and Title, and is accompanied by a page of data containing information specific to that Figure.

Major Electrical Guide Headings	Description
Introduction	Description of Electrical Guide format, interpretation of commonly used acronyms, description of vehicle electrical/electronic system and VIN range
Table of Contents	Listing of each electrical diagram and associated Figure number
Component Index	Listing of all major components and in which Figures they appear
User Instructions	Detailed explanation of Electrical Guide usage
Symbols and Codes	Interpretation of symbols, wiring color codes, wiring harness codes and harness component numbers
Connectors	Illustrations of commonly utilized connector styles
Main Power Distribution	Illustration of battery harness routing through vehicle
Ground Point Locations	Illustration of ground point locations
Harness Layout	Illustration of harness routing through vehicle
Control Module Location	Illustration of module locations
Control Module Pin Identification	Illustration of control module connectors and related pin information
Relay and Fuse Box Location	Illustration of relay and fuse box locations
Figures	Electrical diagrams with associated data pages
Appendix	Message matrix (listing of multiplex messages used on the associated networks)

Typical Electrical Guide Usage

In most circumstances, the technician will begin usage of an Electrical Guide by referring to the Table of Contents for the appropriate Figure Number of the desired schematic. Turning to the appropriate Figure, the tri-fold page for schematic should be unfolded to the right side and the tri-fold data page should be unfolded to the left side. This will display both the schematic and data pages simultaneously. As needed, the technician can refer back to the first section of the Electrical Guide for additional information (i.e. location illustrations, control module pin information, etc.).

Note: Electrical Guides are not market-specific. The user must pay close attention when selecting a Figure to insure that the proper schematic is referenced.

Technical Guides, Focus Series and Guides CD

Technical Guides

Two types of Technical Guides are produced; Technical Introductions and Model Year Updates. Technical Introductions provide a comprehensive technical overview of new models or powertrains while Model Year Updates cover changes in existing models that have undergone significant changes.

Focus Series

The Focus Series provides technical information on specific systems. Each book covers an individual system and will include a technical overview, detailed systems operation, and diagnostic information.

Technical Guides and Focus Series CD

Released in 2000, the Technical Guides and Focus Series CD contains a compilation of all guides released from 1987 - 1999. Adobe Acrobat Reader is required to view the guides and is included on the CD.

Technical Guides and Focus Series CD Contents

FOCUS SERIES

<u>PUB. NO.</u>	<u>DESCRIPTION</u>
S 58	XJ-S Engine Performance (1981-88 MY w/ Lucas Ignition)
S 64	1989-91 MY XJS Coupe & Convertible Body Enhancement
S 70	Electrical System Batteries and Charging Second Edition
S 73	Sedan Power Hydraulic System
S 91	1993-94 AJ6 4.0L Engine Management System OBD I Diagnostic Guide

TECHNICAL GUIDES

<u>PUB. NO.</u>	<u>DESCRIPTION</u>
JTP 425/1	Air Conditioning System HFC Refrigerant Retrofit

XJ6/VDPIXJ12 SEDAN RANGE 1988-94 MY

<u>PUB. NO.</u>	<u>DESCRIPTION</u>
S 63	1988 MY Sedan Range Introduction
S 66	1989 MY XJ6 3.6 Model Year Update
S 69	1990 MY Sedan Range Model Year Update
S 78	1991 MY Sedan Range Model Year Update
S 81	1993 MY XJ6 Sedan Range Model Year Update
S 81	1994 MY XJ12 Sedan Technical Introduction

XJ6/VDPIXJRXJ12 SEDAN RANGE 1995-97 MY

<u>PUB. NO.</u>	<u>DESCRIPTION</u>
JJM 101512/50	1995 MY Technical Guide XJ6 & XJ12 Range Introduction
JJM 181512/55	1995 MY Technical Guide XJ6 & XJ12 Range Supplement 1
JJM 181512/57	1996 MY Technical Guide XJ6 & XJ12 Range (Long Wheel Base Sedan)
JJM 181599/60	1996 MY Technical Guide XJ Sedan & XJS Ranges 1996 MY Update

XJS RANGE

<u>PUB. NO.</u>	<u>DESCRIPTION</u>
--	1986-88 MY Hess & Eisenhardt Convertible Repair Operation Manual
--	1988 MY XJS Model Year Update
S 60	1989 MY XJS Model Year Update
S 60/SUPP	1989 MY XJS Model Year Update Supplement (Marelli Ignition)
S 61	XJ-S Convertible Technical Introduction
S 67	1990 MY XJS Model Year Update
JJM 101506/01	1990 XJS Convertible Technical Guide
S 71	1992 MY XJS Technical Introduction
S 79	1993 MY XJS Model Year Update
S 80	XJR-S Product Support
S 83	1994 MY XJS Model Year Update
S 92	1995 MY XJS Model Year Update
JJM 101506/52	1995 MY XJS Update from VIN 198335
JJM 181599/60	1996 Technical Guide Sedan & XJS 1996 MY Update

XJ8/VDPIXJR

<u>PUB. NO.</u>	<u>DESCRIPTION</u>
JJM 181512/80	1998 MY Technical Guide V8 XJ Series Sedan 1998 MY Introduction
JJM 181518/90	1999 MY Technical Guide XJ and XK Series 1999 MY Update

XK8

<u>PUB. NO.</u>	<u>DESCRIPTION</u>
JJM 181514/70	1997 MY Technical Guide XK8 Sports Coupe and Convertible Introduction
JJM 181515/70	1997 MY Technical Guide AJ-V8 Engine and 5HP24 Transmission Introduction
JJM 181518/90	1999 MY Technical Guide XJ and XK Series 1999 MY Update

Diagnostic Trouble Code Summaries

DTC Summaries are a compilation of diagnostic trouble codes for all major vehicle systems that support onboard diagnostics. DTC Summaries include detailed information for each code

Diagnostic Trouble Code Contents

Table Heading	Description
DTC	Code number
Fault Description	Subsystem or component associated with the DTC
Monitoring Conditions	Operating conditions under which a system self-test will be performed on described system or subcomponent
OBD II (selected systems)	Indicates if DTC is an OBD II DTC
Tool (selected systems)	Indicates if the DTC can be accessed via a generic scan tool or will require WDS/PDU/GDS
CK Engine	Indicates the drive trip(s) required to activate the CHECK ENGINE MIL
Other	Lists driver warnings associated with DTC (if any)
Default Action	Lists default actions initiated by system control module in response to the DTC
Possible Causes	Lists possible faults that could cause the DTC

Note: a detailed interpretation of table headings is included in the introduction pages of each DTC Summary section.

Typical DTC Table

DTC	FAULT DESCRIPTION	MONITORING CONDITIONS	OBD II	CK ENG	OTHER	DEFAULT ACTION	POSSIBLE CAUSES
P0010	VVT Circuit malfunction – A bank	Drive vehicle; accelerate rapidly to cruise, decelerate to stop, repeat several times	Y	2	N	When CK ENG MIL is activated (DTC flagged; second trip), ECM: Sets VVT drive PWM duty cycle to 0 (intake camshaft fully retarded)	VVT solenoid valve to ECM PWM drive circuit fault VVT solenoid valve to ECM ground circuit fault VVT solenoid failure
P0020	VVT Circuit malfunction – B bank	Drive vehicle; accelerate rapidly to cruise, decelerate to stop, repeat several times	Y	2	N	When CK ENG MIL is activated (DTC flagged; second trip), ECM: – Sets VVT drive PWM duty cycle to 0 (intake camshaft fully retarded)	VVT solenoid valve to ECM PWM drive circuit fault VVT solenoid valve to ECM ground circuit fault VVT solenoid failure
P0101	MAFS range / performance	Engine at normal operating temperature; drive at steady speed on level surface 43 – 59 mph (70 – 95 km/h); 1500 – 2500 rpm; > 10 seconds Fuel level > 10%; surface elevation < 8,000 ft (2,438 m)	Y	2	2 [A, M]	When CK ENG MIL is activated (DTC flagged; second trip), ECM: – Substitutes throttle angle for engine load measurement – Limits engine speed to 3000 rpm – Inhibits canister purge	Blocked air cleaner Air intake leak Engine breather leak Throttle control malfunction MAFS to ECM sensing circuit high resistance MAFS to ECM sensing circuit intermittent short circuit to ground MAFS supply circuit high resistance MAFS failure
P0102	MAFS sense circuit low voltage	Ignition ON > 5 seconds	Y	2	1 [A, M]	When AMBER MIL is activated (DTC logged; first trip), ECM: – Substitutes throttle angle for engine load measurement – Limits engine speed to 3000 rpm – Inhibits canister purge	Blocked air filter MAFS to ECM sensing circuit high resistance or open circuit MAFS to ECM sensing circuit intermittent short circuit to ground MAFS supply circuit open circuit or short circuit to ground MAFS failure

The following code prefixes are used:

P – Powertrain

B – Body

C – Chassis

U – Network

Beginning in 1995 and ending in 2002, Jaguar has provided DTC Summaries in print. From 2001 onwards, DTC Summaries are available on CD and can be viewed using Adobe Acrobat Reader. The CD version contains all DTC Summaries since 1995.

JAGUAR TECHNICAL INFORMATION SYSTEM

Jaguar Technical Information System is a computer program that provides Jaguar technicians with service manuals on compact disc. JTIS is utilized on the Jaguar Multimedia computer in each service department. JTIS allows Technicians to view service information for a specific vehicle and model year. This includes information such as:

- General Procedures
- Specifications
- Description and Operation
- Removal and Installation
- Diagnostic and Testing

JTIS contains service information for sedans beginning with the 1995 MY XJ6 and for coupes beginning with the 1997 MY XK8. Compared to service manuals in print, JTIS can be updated more quickly, updated at lesser expense, and shipped more easily. All service manuals are contained on a single JTIS CD. With each update, a replacement CD is issued. Each CD is labeled with the date of release and the edition number (revision number).

Navigator Display



JTIS Screen Elements

Menu Bar:

The menu bar is beneath the title bar and contains the menus. “Click” on a menu to open it.

File Edit Search Navigate View Help

Tool Bar:

The tool bar is beneath the menu bar and contains the Exit, New, Service, Electrical Diagrams, DTC Summaries, and Help buttons. The New button displays a listing of changes in the current JTIS edition over the previous edition.



Navigation Bar:

The navigation bar is beneath the display area and contains the navigation buttons. A brief description of the button function is shown when you move the Mouse Cursor over a button and wait for a moment.



Status Bar:

The status bar is at the bottom of the screen. The left part of the status bar shows a short description for a menu command or a button when you move the Mouse Cursor over it. The right part of the status bar shows the current model, model year and the current document, date and time.

Ready Current Location XK8 1998 412-01 03-11-1998 17:52

Vehicle Selection

The model year and the vehicle must be specified before service information can be accessed.

To select a service information manual using year and vehicle:

1. Click on the “Service” button in the tool bar. The “Select Service Manuals Year and Vehicle” dialog box appears:
2. Click on a model year.
3. Click on a vehicle.
4. Click on the “OK” Button

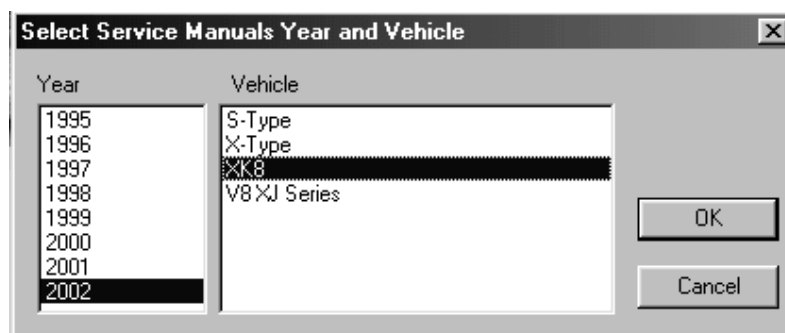





JTIS provides three primary ways of locating service information; JTIS Navigator, JTIS Graphical Navigator and Search (Global, Local, SRO and Torque search)

The JTIS Navigator is the structured table of contents for available service information.

The JTIS Navigator displays automatically in the left part of the display area when a new service information manual is opened. The display level is the group level. You can switch between Full Screen and Display Navigator.

There are symbols for every navigator entry to show the structure:

-  Plus Symbol This entry contains subentries. The subentries are not displayed yet. Click on the plus symbol to expand the subentries.
-  Minus Symbol This entry contains subentries. The subentries are displayed now. Click on the minus symbol to collapse the subentries.
-  Point Symbol This entry is a document. Click on the document to open it.
-  Arrow Symbols This is your current position in the structure. Click on an entry text (not the symbol) to change the position.
- 

Navigator Main Display

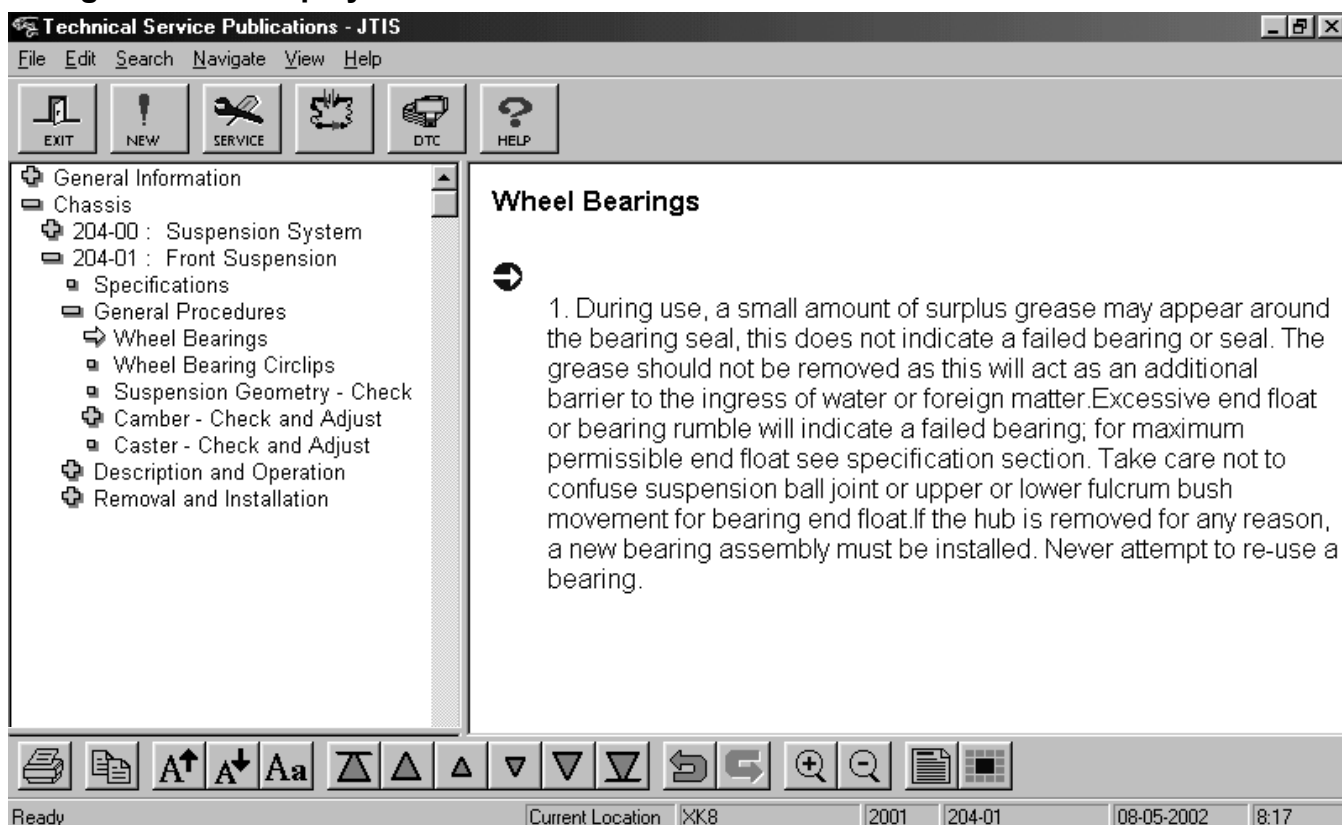

The screenshot shows the 'Technical Service Publications - JTIS' window. The menu bar includes File, Edit, Search, Navigate, View, and Help. The toolbar contains icons for EXIT, NEW, SERVICE, DTC, and HELP. The left pane displays a tree view under 'General Information' with the following structure:

- General Information
 - Chassis
 - 204-00 : Suspension System
 - 204-01 : Front Suspension
 - Specifications
 - General Procedures
 - Wheel Bearings (Current position)
 - Wheel Bearing Circlips
 - Suspension Geometry - Check
 - Camber - Check and Adjust
 - Caster - Check and Adjust
 - Description and Operation
 - Removal and Installation

The right pane displays the 'Wheel Bearings' document content:

Wheel Bearings

1. During use, a small amount of surplus grease may appear around the bearing seal, this does not indicate a failed bearing or seal. The grease should not be removed as this will act as an additional barrier to the ingress of water or foreign matter. Excessive end float or bearing rumble will indicate a failed bearing; for maximum permissible end float see specification section. Take care not to confuse suspension ball joint or upper or lower fulcrum bush movement for bearing end float. If the hub is removed for any reason, a new bearing assembly must be installed. Never attempt to re-use a bearing.

The status bar at the bottom shows 'Ready', 'Current Location XK8', '2001', '204-01', '08-05-2002', and '8:17'.

The JTIS Graphical Navigator is a pictorial display of available service information.

The Graphical Navigator is automatically displayed after a vehicle has been selected. An image representing the selected model is shown in the center of the screen and is surrounded by images representing the main target groups.

Graphical Navigator Main Display



When “clicking” on a main group image, the following screen will show an image representing the main group surrounded by images representing each section.

Navigator Main Display *Chassis group displayed*

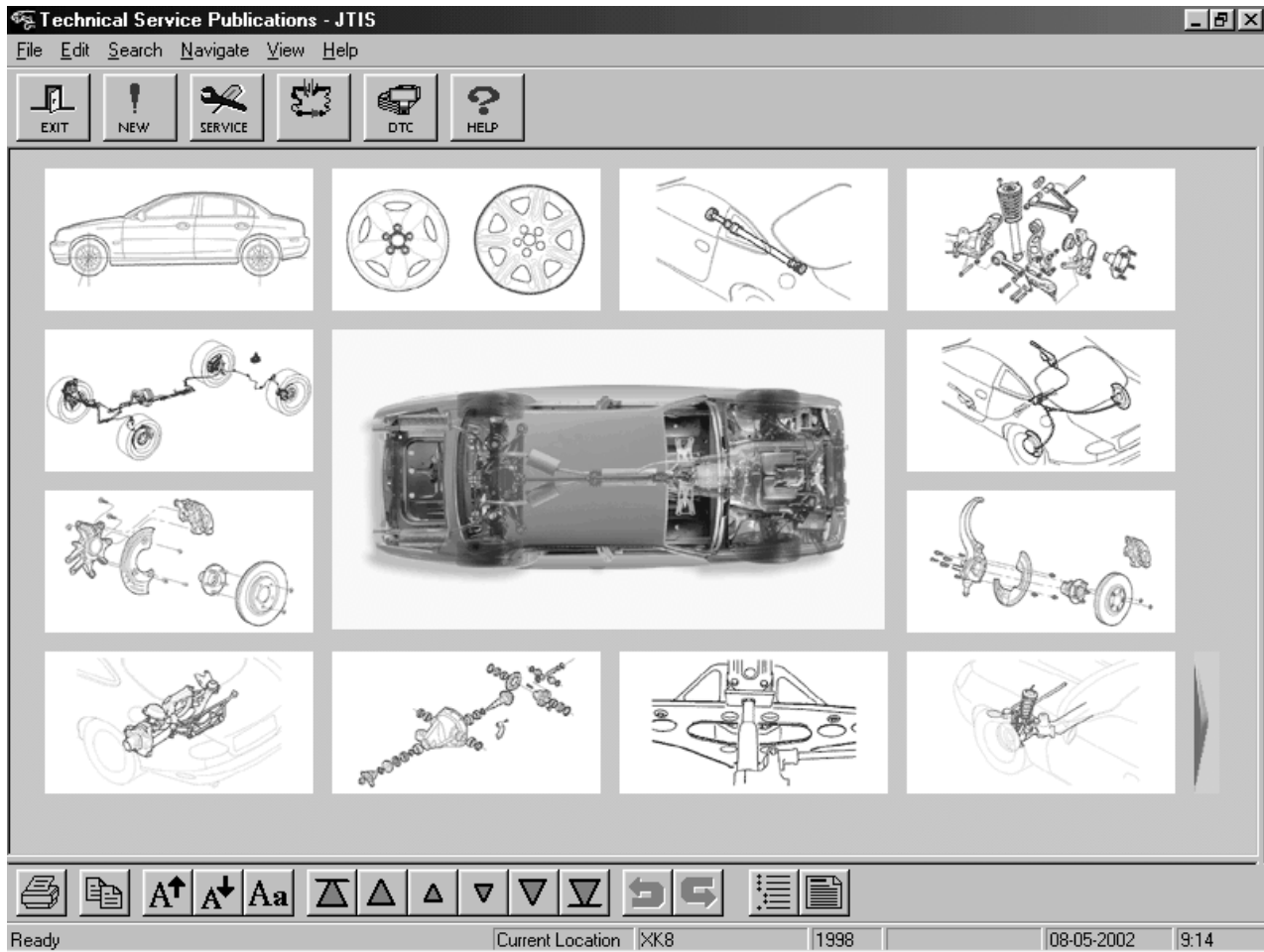

The Search menu provides four ways of location service information

Selecting Search from the Menu Bar provides the four following options:

- Local Search – searches current document for matches
- Global Search – searches all documents for matches
- SRO Search – searches for matching Service Repair Operation number
- Torque Search – searches for torque specifications for described component



After selecting one of the four options, enter the description of the information desired, then select OK

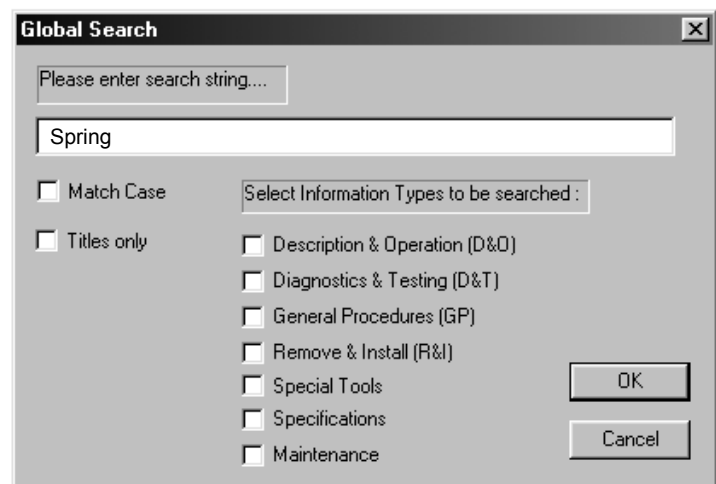

A dialog box containing all search matches is displayed. Click on the desired document and select OK to display desired information.

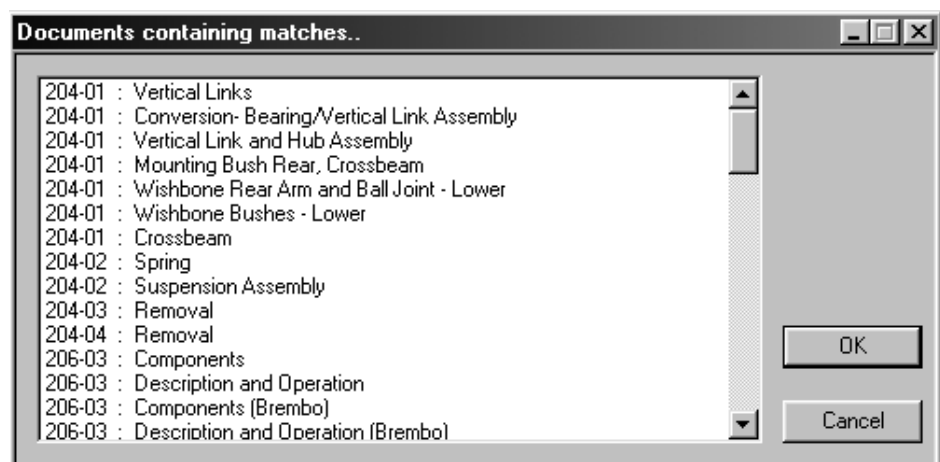

Display Area:

The display area is between the Tool Bar and the Navigation Bar. The display area covers most of the screen and is split into a left part and a right part.

- Left Side: Contains the JTIS Navigator or a graphic that corresponds to the currently displayed service information.
- Right Part Contains the service information text.

Graphic Display

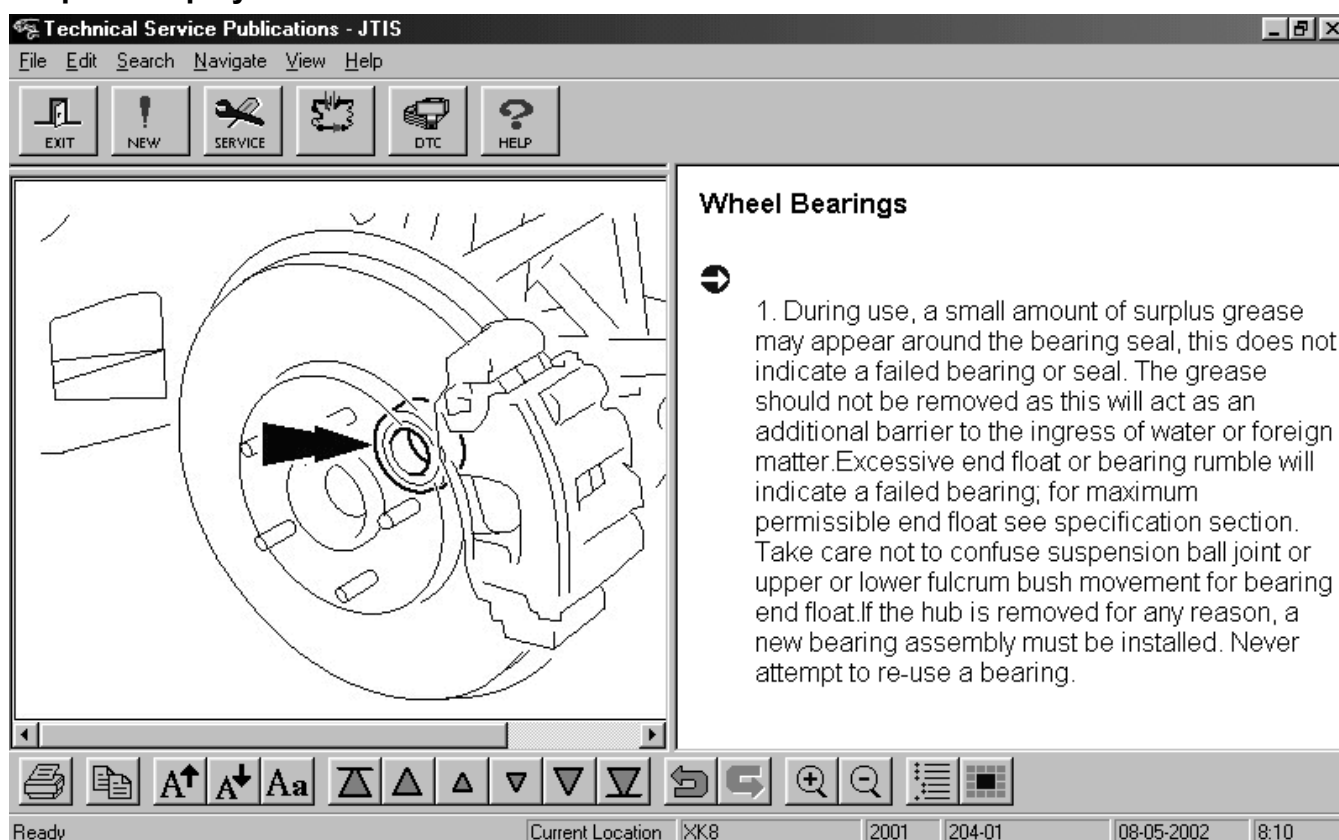

Electrical Guides



Electrical diagrams can be accessed through the “Electrical Guides” button on the tool bar. After selecting a model year and vehicle, JTIS will launch Adobe Acrobat. This is a separate program from JTIS and provides the ability to view diagrams. The Electrical Guides contained in JTIS are an electronic version of those provided in print by Jaguar Cars.

Diagnostic Trouble Code Summaries



DTC Summaries can be accessed through the “DTC” button on the tool bar. After selecting a model year and vehicle, JTIS will launch Adobe Acrobat. This is a separate program from JTIS and provides the ability to view DTC Summaries. The summaries contained in JTIS are an electronic version of those provided in print by Jaguar Cars.

Printing Documents



After the desired service information has been displayed, it can be printed. Printing can be accessed through the File option on the menu bar or the “Printer” button located on the navigation bar. Up to four print options will be presented before printing will be executed.

- **Print All** The entire document, including graphics, will be printed.
- **Print Pages** This option will allow the user to select which pages of the document to print (this is particularly useful when working with large documents).
- **Print Selection** Only the portion of the document that has been highlighted by the user will be printed (highlighting of text is achieved by “click-and-holding” the left mouse button, then dragging the mouse cursor across the desired text).
- **Shrink To Fit** When using DTC Summaries or Electrical Guides, this option will allow the user to fit a large image, such as an electrical diagram, onto a single page.

Help



Selecting the “Help” button on the tool bar will display a table of contents for the available online help.

Refer to “Help” for further information concerning the use of JTIS.

Service Bulletins

Service bulletins are published and distributed to update the Jaguar dealer organization with the latest service information. A quantity of bulletins, specified by the dealer, is mailed directly to the dealer service manager. Jaguar suggests that every technician be given copies of service bulletins.

Service bulletins are categorized as Administration Bulletins and Technical Bulletins. Technical bulletins contain the latest service information, updates to specifications and repair procedures, special repair procedures and other information that is directly related to the technical job of diagnosing and repairing vehicles. Administration Bulletins cover non-technical service matters such as changes and updates to service programs, tool and literature information, training information and general workshop administrative issues.

Service bulletins are organized in their respective binders by subject matter. Bulletins within each subject group are sequentially numbered so that they can be easily files and any missing bulletins will be easily identified.

Technical Bulletins

Technical bulletins are organized into three separate binders for ease of access; XK8/XJ8 binder, S-Type binder, and X-Type binder. The numbering system for all three binders is the same.

Technical Bulletin Numbering System

Group	Subject
100	General Information, ID Codes, Jacking & Lifting, NVH
204	Suspension System
205	Driveline System
206	Brake System
211	Steering System
303	Engine System
307	Transmission
309	Exhaust Components
310	Fuel System
412	Climate Control
413	Information, Gauge, and Warning Group
414	Electrical Power Supply System
415	In-Vehicle Entertainment System
417	Lighting System
418	Electrical Distribution & Electronic Control System
419	Electronic Feature Group
501	Body System
600	Maintenance
910	Squeaks and Rattles
920	PDU & WDS

Note: S-Type and X-Type bulletin group numbers are preceded by an "S" or "X", respectfully.

Typical Technical Bulletin

Model group

Original date of issue and date of amendment (if applicable)

Group and issue number
206-07 = 7th bulletin issued for group 206 (Brake Systems)



V8 XJ Series/XK8

DATE 04/98
Amended 04/00

206-07

SERVICE

TECHNICAL BULLETIN

Brake Pedal Switch – Parts Inventory Simplified

MODEL
1997 MY-ON XK8 Range
1998 MY-ON V8 XJ Series

VIN
001001-ON
812256-ON

Remove and destroy Bulletin 206-07, amended 11/98.
Replace with this Bulletin.
Revisions are marked with a bar and in **bold text**.

Issue:

Brake pedal switch assemblies were changed in production (Illustration 1) from the following VINs:

XK8 VIN **A03098**
V8 XJ Series VIN **F05566**

These switch assemblies are the only ones now available and can be installed on earlier vehicles.

Action:

The current brake pedal switch assembly (date code 44/99) , as listed on the next page, must be installed if replacement of the switch is necessary.

Note: When the cruise control is in operation, a malfunctioning brake switch can cause FAILSAFE to display in the message center and cause a DTC P1571 to be stored in the ECM.

BRAKE PEDAL SWITCHES



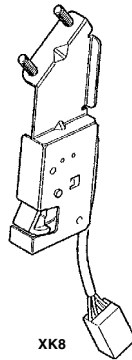

V8 XJ SERIES

XK8

ILLUSTRATION 1

Date of issue

Date of issue 04/98 Amended 04/00



Bulletin Number 206-07 Page 1 of 2

Bulletin & page number

Title

Detailed explanation of fault/concern

Bars are placed on amended bulletins beside revised information (revised text appears in bold)

Detailed explanation of repair procedure

Applicable model(s)

Applicable VIN range(s)

Amended bulletins include instructions to destroy original and replace with amended version

Notes, Cautions & Warnings are emphasized with a border

Illustrations

Typical Technical Bulletin

	Description of parts required		Part numbers	Quantity of parts required	
	Parts Information:				
	DESCRIPTION		PART NUMBER	QTY	
	Brake pedal switch XK8		LJB 6420BB	1	
	Brake pedal switch V8 XJ Series		LNB 6420BB	1	
	Warranty Information:				
Fault code	FAULT CODE	R.O. NUMBER	DESCRIPTION	TIME ALLOWANCE	Time allowances
	QN FB 28	86.65.51	Replace brake light switch - XK8	0.10 hrs.	
		86.65.51	Replace brake light switch - V8 XJ Series	0.10 hrs.	
		86.99.97	Connect PDU for download capture/printout	0.15 hrs	
		86.99.99	PDU test time	0.30 hrs.	
Repair operation numbers					Repair operation description
Bulletin & page number					Date of issue



Administration Bulletins

Administration bulletins are organized into a single binder.

Administration Bulletin Numbering System

Group	Subject
1	Tools and Equipment (i.e. WDS)
2	Training (i.e. schedules)
3	Warranty
4	Maintenance and PDI Schedules
5	Repair Operation Times
6	Workshop Administration (i.e. JTIS)
7	Recalls and Campaigns

Typical Administration Bulletin

	Applicability	Original date of issue and date of amendment (if applicable)	Group and issue number 6-99 = 99 th bulletin issued for group 6 (Workshop Administration)
	All	DATE 05/02	6-99
Title			
	Jaguar Technical Information System (JTIS) – Issue 16 – Workshop Manual – CD-ROM		Applicable models
Detailed explanation of fault/concern	<p>ISSUE: Workshop manual information for 2002 X-TYPE, 2000-2002 MY S-TYPE, 1995-2002 MY Sedan Range, and 1997-2002 MY XK8 has been released on CD-ROM Part No. JJM 10 30 99/203. The new 2003 MY S-TYPE is covered, but listed under 2002 MY. This CD-ROM can be used on the Jaguar multimedia PC or any suitable Windows-based PC with a minimum 133 MHz processor, 2.0 Gb hard drive, 8x CD-ROM drive, and 24 Mb RAM.</p>		Applicable VIN ranges
Detailed explanation of action procedure	<p>ACTION: Ensure that the software is stored inside the PC storage cabinet with all other Jaguar multimedia PC CD-ROMs. Refer to the inside cover of the CD-ROM jewel case for installation instructions. Once this CD-ROM has been installed, the system will not accept the JTIS Issue 15 CD-ROM.</p>		Notes, Cautions & Warnings are emphasized with a border
	<div style="border: 1px solid black; padding: 5px;"> <p>Note: You must install JTIS 16 to have access to all new information. Click on the NEW button to review the added information.</p> </div>		
	<p>INSTALLATION TIPS</p> <ul style="list-style-type: none"> You do not have to install Acrobat Reader 3.0, if you already have a later version (4.0 or 5.0). Clicking OK only closes the message window - it does not install Acrobat. The first time you install JTIS on a PC, you may have to install Data Access Objects 3.5. Clicking OK only closes the message window - it does not install the component. If necessary, install DAO 3.5 by navigating to dao35\DISK1\Setup.exe on the JTIS CD-ROM. 		
Date of issue	Date of issue 05/02		Bulletin & page number
		Bulletin Number 6-99 Page 1 of 1	

Service Actions, Campaigns & Recalls

Campaign

A campaign is a category or warranty transaction. It is used as in general communications around "Types of Warranty Transactions". There two types of campaign 1) Service Action 2) Recall.

Service Action

A service action is a repair to a specific product concern. There is no customer notification. A Service Action is performed based on either a customer complaint (the problem MAY occur) or the first service opportunity (the problem WILL occur sooner or later). In time all service actions will be closed. Service Actions are claimable only while the vehicle is within the terms of the New Car Warranty.

Recall

A recall is also a repair to specific product concerns. However, vehicle owners/drivers are notified. There will also be reporting of completion rates to Federal agencies, State Agencies or both. Short of a 100% completion rate, Recalls are never closed. Recalls are claimable regardless of the New Car Warranty status.

Forms

Several forms exist to assist Jaguar service technicians. These forms insure complete reporting and proper procedure for various service operations. Below is a listing of forms more commonly used by technicians.

Form Number	Description
W,18	Battery Test Report
W,27	In Car Entertainment Warranty Parts Return Form
W,28	Automatic Transmission Evaluation Report
W,29	PAS Rack and Pinion Evaluation Form
S,18	Vehicle Maintenance Checklist: XJ6 and Vanden Plas 1988-1989 MY
S,18,4	Vehicle Maintenance Checklist: Sedan Range 1990-1994 MY
S,1897,SED	Vehicle Maintenance Checklist: Sedan Range 1995-1997 MY
S,18,XJS	Vehicle Maintenance Checklist: XJS (through 1994 MY)
S,1898	Vehicle Maintenance Checklist: All 1998 Models
S,1899	Vehicle Maintenance Checklist: All 1999 Models
S,18,00	Vehicle Maintenance Checklist: All 2000/2001 Models
S,18,02	Vehicle Maintenance Checklist: All 2002 Models
S,88	Technical Hotline Precall Worksheet
S,93	OBD II Report (Note: Replaced by Electronic OBD II Report online at the EPQR website)
S,94	Product Quality Report (Note: Replaced by Electronic OBD II Report online at the EPQR website)
S,95	Vibration Report: All Jaguar Vehicles 1988 MY on
S,97	Alignment Report: 1995 MY on

Note: Selected repair operations require proper form submission for warranty reimbursement

Jaguar Business Network (JBN) Online

The JBN-online website is a one-stop shop for all kinds of dealer-related information. This dealer-only website, provides both sales and service dealer personnel a wide variety of research and information choices.

The JBN online home offers the user all the different areas the dealer can select to obtain information.

Even though all selections on the main page are of great advantage to the user, there are some selections, which are very useful to the service department user. The following sections will provide you with an overview of these service-related areas

Service Support

This section, offers the user access to:

- Service & Parts bulletins
- Service Actions & Recalls
- PI Department Technical E-mail
- Jaguar Service Support partners
- Global Vehicle Specifications

This site provides on-line versions of service bulletins covering North American Specification (NAS) or USA specification Jaguar vehicles.

Training & Recognition Program

This section, offers the user access to:

- Introduction to Jaguar
- Sales Training
- Parts & Service Training
- Customer Care
- And several other important areas

The Parts and service page offers several selections which are commonly utilized by service department personnel.

For example, all self-study training programs require the technician to complete the course by taking an online test. The user automatically receives credit for the course upon successful completion.

The technical training home page offers all service personnel a complete list of all available service-training courses. Each course includes a brief description of the prerequisites, number of days and required materials.

Technical Training Schedule

The schedules are shown in 3-month periods and are easy to interpret with such features as specific colors for each training center.

Parts & Service Marketing

This section, offers the user access to:

- Vehicle accessories
 - Jaguar Tire Program
 - Service Loaner Program
 - Roadside assistance program
 - And several other important programs
-

Electronic Product Quality Reports (EPQR)

The EPQR system is a quick and easy way for the dealers to report vehicle quality concerns directly to Jaguar Cars North America Product Investigation (PI) department and Jaguar Cars Limited (JCL) engineering groups. All Jaguar dealers have access to a web site (Fig. 1) where the EPQRs and OBD-II reports (S93) can be electronically submitted.

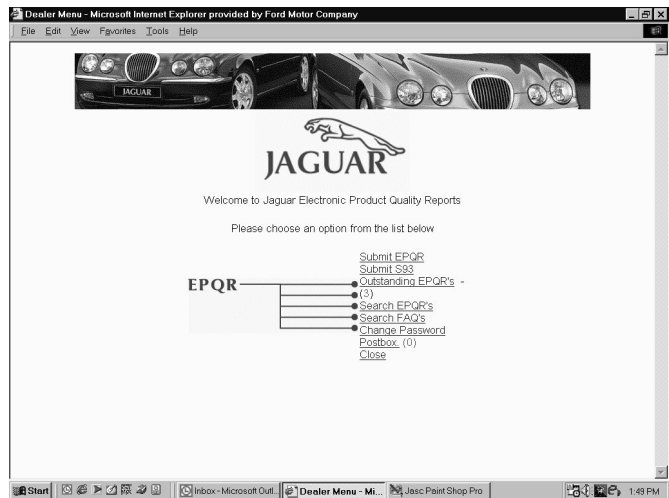

Fig. 1 Jaguar Cars EPQR home page

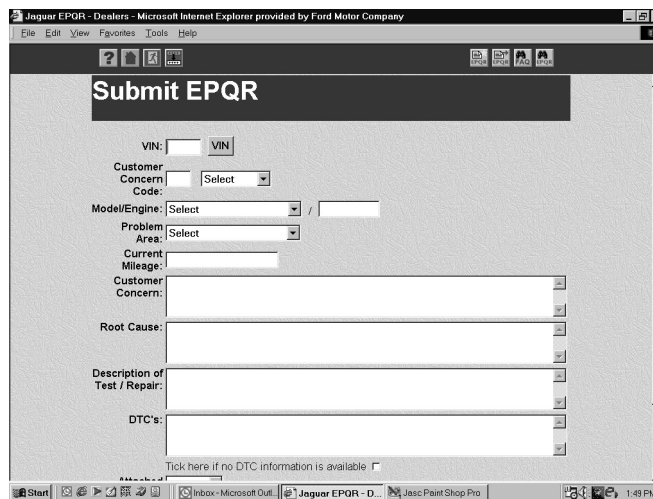

Fig. 2 EPQR submit Form

The Submit EPQR page (Fig.2), allows the technician to enter the details of the concern into the relevant fields. Clicking on the Submit button at the bottom of the page will send the EPQR on its way.

The report is electronically delivered to the appropriate product investigation analyst at JNA. The analyst reviews the report and if necessary, modifies it for transmittal to the appropriate component-engineering group or engineer at JCL.

Once Jaguar Cars UK investigates the concern, the findings and appropriate actions are sent back to JNA for final review and if necessary modification of any instructions before forwarding the information to the dealer.

Electronic Product Quality Reports (EPQR)

The user can keep track of the status of the investigation by going to the outstanding EPQRs page (Fig.3), and checking on the EPQR submitted.

Not only can the user view the status of the report but can also edit the report by clicking on the relevant reference number in the left hand column of the table.

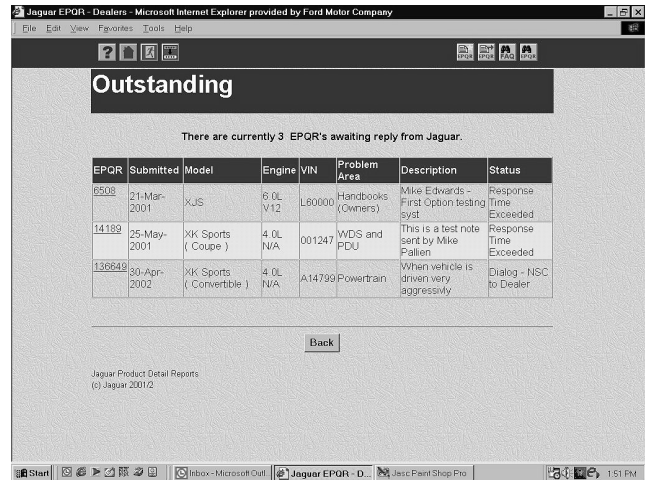

Fig. 3 Outstanding EPQRs page

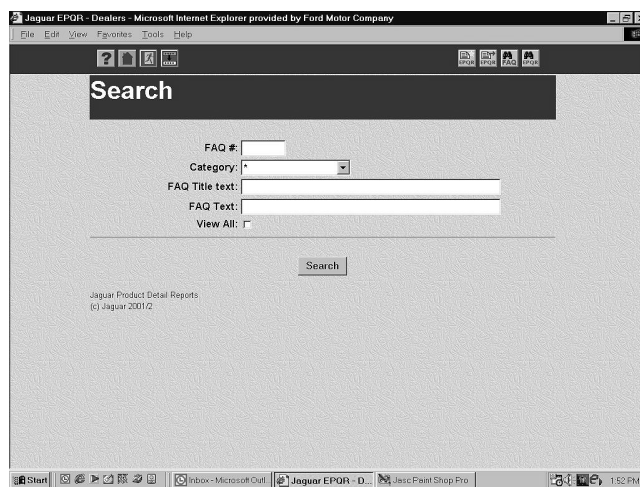

Fig. 4 FAQ search Form

Another feature that the EPQR site offers is the Frequently Asked Questions (FAQs) search form (Fig. 4). This feature offers the technician a quick way of checking for similar concerns already investigated or product investigation reports on the issue. Once the appropriate fields are filled out on the search form (Fig.5), the results of the search are on shown in full detail (Fig. 6)

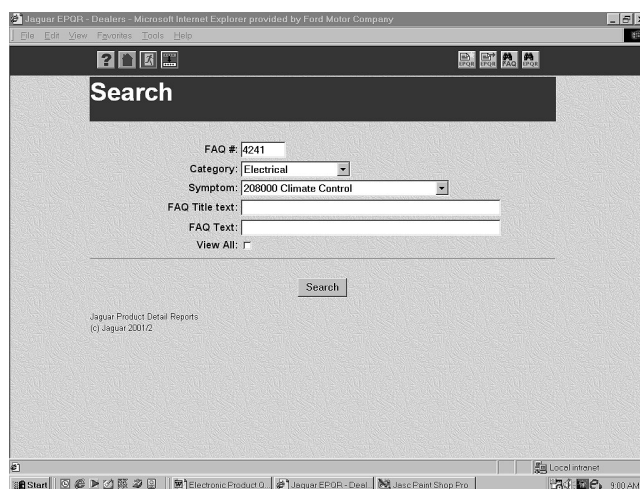

Fig. 5 Search options

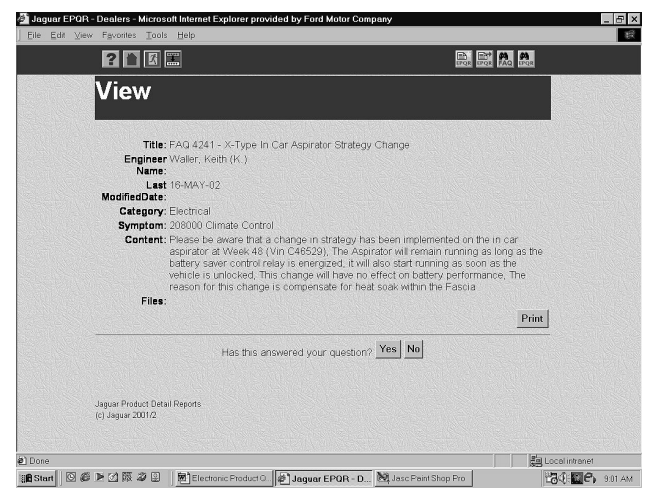

Fig. 6 FAQ search results

Electronic Product Quality Reports (EPQR)

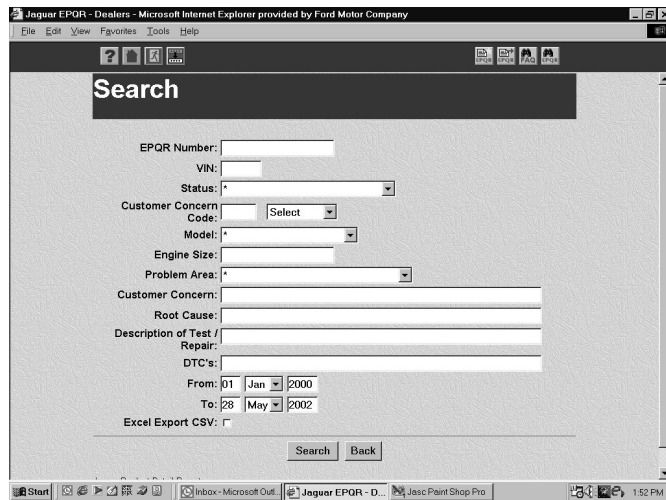
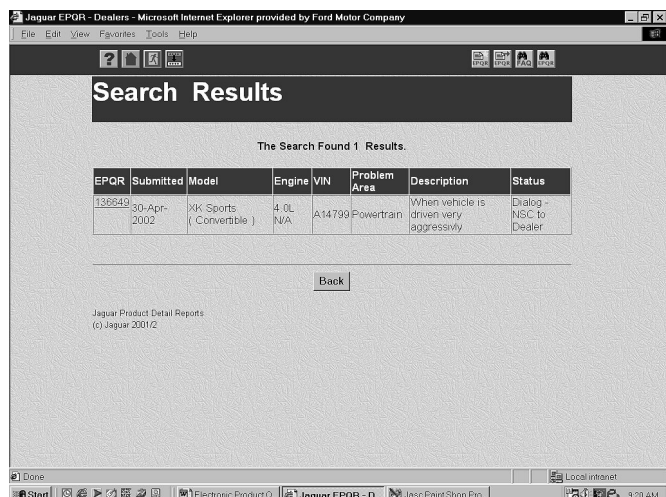

Fig.7 EPQR Search screen

In addition to the FAQ, the user can also perform a more detailed search using the search EPQR form (see Fig. 7).

The search EPQR page allows the user to search using the various criteria in any combination required. One can therefore view both recent and historical EPQRs and also search for EPQRs relating to specific areas.

Once the appropriate fields are filled out, the results are shown on a different page (Fig. 8). Clicking on the EPQR number takes the user to a new page with all the details of the investigation (Fig. 9)



EPQR	Submitted	Model	Engine	VIN	Problem Area	Description	Status
136649	30-Apr-2002	XK Sports (Convertible)	4.0L N/A	A14799	Powertrain	When vehicle is driven very aggressively	Dialog - NSC to Dealer

Fig. 8 EPQR search results page

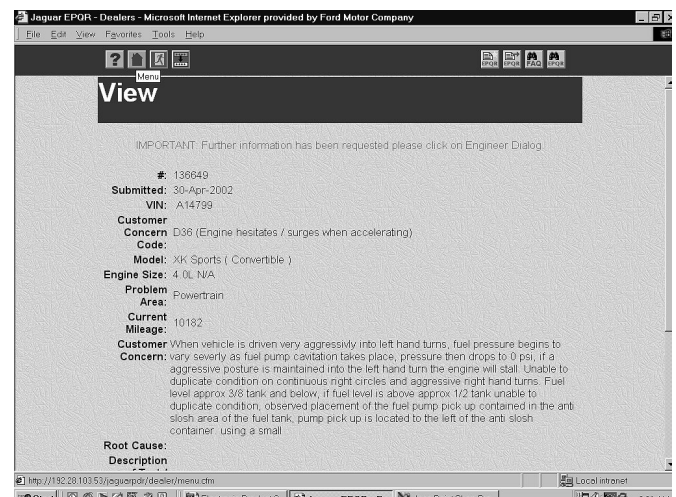

IMPORTANT: Further information has been requested please click on Engineer Dialog.

#: 136649
 Submitted: 30-Apr-2002
 VIN: A14799
 Customer Concern Code: D38 (Engine hesitates / surges when accelerating)
 Model: XK Sports (Convertible)
 Engine Size: 4.0L N/A
 Problem Area: Powertrain
 Current Mileage: 10182
 Customer Concern: When vehicle is driven very aggressively into left hand turns, fuel pressure begins to vary severely as fuel pump cavitation takes place, pressure then drops to 0 psi, if a aggressive posture is maintained into the left hand turn the engine will stall. Unable to duplicate condition on continuous right circles and aggressive right hand turns. Fuel level approx 3/8 tank and below, if fuel level is above approx 1/2 tank unable to duplicate condition, observed placement of the fuel pump pick up contained in the anti slosh area of the fuel tank, pump pick up is located to the left of the anti slosh container using a small

Root Cause:
 Description:

Fig. 9 EPQR search results detailed file

Electronic Product Quality Reports (EPQR)

In addition to the submitting EPQRs, dealers can also attach the OBD-II concern report (Form S-93). This form is used by technicians to report OBD-II powertrain malfunction indicator light (MIL) occurrences on OBD-II equipped vehicles.

Using the WDS - S93 menu tab, the user can save all the pertinent data into a report, which is uploaded using the Submit S93 screen (Fig. 10) on the EPQR menu screen followed by choosing the appropriate file adding it to the file field (Fig. 11) and submitting.

Both the EPQR and S93 forms are very important to Jaguar Cars North America and Jaguar Cars Limited. Not only do they inform the appropriate engineering groups of any important vehicle concerns, but also the US environmental protection agency (EPA) requires all vehicle manufacturers to submit any emissions related concerns after a certain number of occurrences.

For more information on accessing the EPQR website or any additional information, refer to Administrative Bulletin 6-93 (Electronic Submission of Product Quality Reports and S-93 Data), date of issue 07/01.

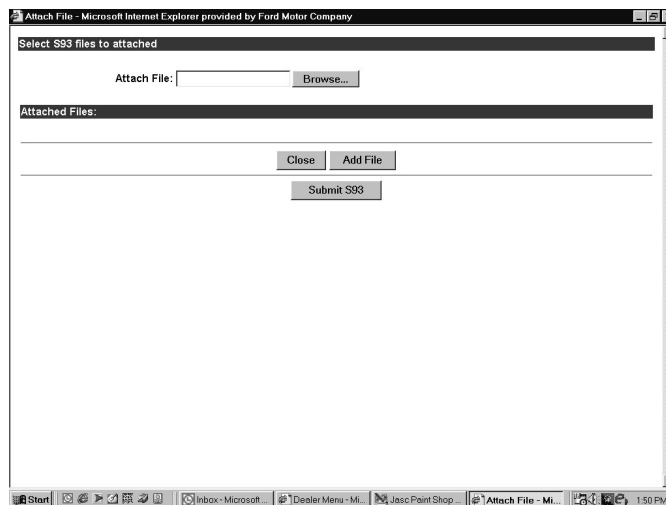

Fig. 10

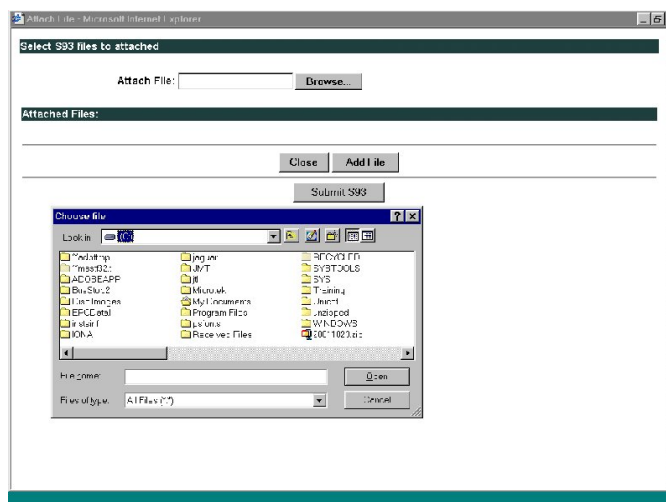

Fig. 11

Special Tools

Special tools are designed for service operations that cannot be performed proficiently, properly, or safely using general hand tools or shop equipment. Special tools are numbered using a global numbering system. This system utilizes a six-digit numbering system; the first three digits are the service group, the last three digits are the tool number within the group (i.e. 303-536 is the number for AJV8 engine lifting plates).

Special Tools Numbering System

Group	Subject
100	Miscellaneous
204	Suspension
205	Driveline
206	Brakes
211	Steering
303	Engine
307	Transmission
310	Fuel System
412	Climate Control
418	Electrical
501	Body

Storage and organization of most tools are facilitated through the Jaguar Tools Storage System. This system consists of mobile storage cabinets for XK8/XJ8, S-Type, and X-Type special tools.

Special tools are automatically sent to each dealership whenever new tools are introduced. Special tools can also be purchased directly from the SPX Corporation (1-800-533-5338). Special tool catalogues are automatically shipped to Jaguar dealerships whenever they are revised. Tools not utilizing the global numbering system are identified by a Jaguar part number and are available through the Jaguar Parts Department.

Worldwide Diagnostic System (WDS)

Introduced in 2000, WDS is Jaguar's primary diagnostic system. Operating on a Windows 98 platform, WDS utilizes a Pentium II microprocessor, 6.4-gigabyte hard drive, and a 12" color, touch-sensitive screen. Most vehicle systems interfacing are achieved through the Data Link Connector (DLC).

WDS capabilities include:

- Guided diagnostics
- Monitor/record system signals (Datalogger)
- Extract/clear fault codes
- CM reflashing
- Connector information (Connector Viewer)
- CM programming
- Vehicle Vibration Analyzer (VVA)
- Digital Multimeter
- Four-trace oscilloscope
- On Demand Self Test (ODST)
- Output State Control (OSC)
- Vehicle setup
- CM interrogation
- Data Recorder access

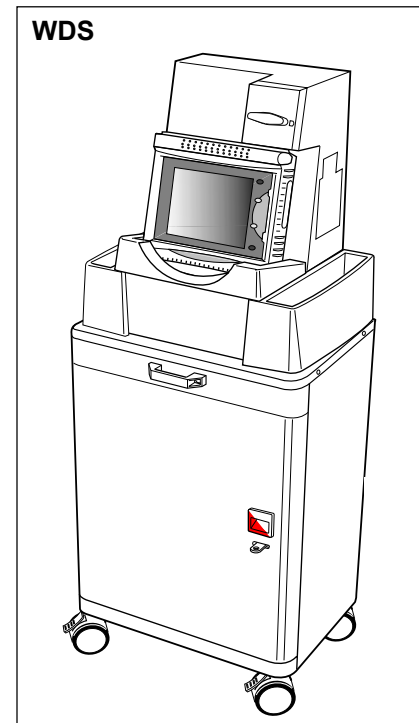

WDS software is updated regularly to provide coverage of all current Jaguar models. All applications are contained on a single CD that is updated every 30-60 days.

WDS Vehicle Coverage

<u>MY</u>	<u>Model</u>
1995-1997	Sedan Range
1996-1997	XJS
1997-on	XK8
1998-on	XJ8
2000-on	S-Type
2002-on	X-Type

Note: refer to the latest Administration Bulletin for current WDS vehicle coverage.

Jaguar offers a two-day, instructor-led WDS course.

Portable Diagnostic Unit (PDU)

PDU is a computer-based, software-driven diagnostic tool. PDU communicates with vehicle systems via a serial communications diagnostic connector or CM interface adapter. The systems supported through serial communications include engine management, transmission, security, instrumentation, braking, climate control and air bag supplementary restraints. Systems not supported through serial communications are supported through directed diagnostics using PDU as a multimeter.

PDU's capabilities include:

- Monitor/record system signals (Datalogger)
- Extract/clear fault codes
- Enable/disable programmable features
- ECM reflashing
- Vehicle setup
- Connector information (Vehicle Data Viewer)
- Guided diagnostics
- Digital multimeter (DMM)
- Vehicle Vibration Analyzer (VVA)

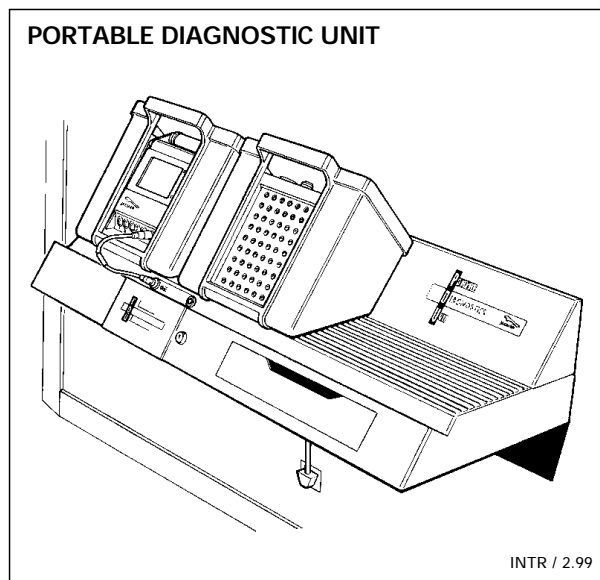

Since the introduction of PDU in 1993, PDU's application software has been continuously updated to improve its performance and provide the capability to interface with newer vehicles and their subsystems. The Worldwide Diagnostic System (WDS) was introduced in 2000 to replace PDU and, as a result, the final two revisions of PDU software were released in 2001.

PDU Vehicle Coverage and Software Applications

MY	Model	Software
1990-1996	XJS	JTP 626/7
1990-1994	Sedan Range	JTP 626/7
1995-2001	XJ Series	JTP 627/10
1997-2001	XK8	JTP 627/10
2000-2001	S-Type	JTP 627/10

PDU's expanded capabilities, small size and portability have proven a valuable resource in the hands of trained technicians. As with all diagnostic aids, an understanding and knowledge of the vehicle system being tested is required to maximize PDU's effectiveness.

While Jaguar no longer provides instructor-led factory training courses for PDU, a multimedia training CD designed to familiarize the new user with PDU usage is part of the in-dealer multimedia training library.

GDS 500E

Introduced in 1997, GDS 500E is Jaguar's first generic scan tool. While GDS 500E was specifically designed for use on Jaguar vehicles, it will also work on most other foreign and domestic OBDII-compliant vehicles. The tool is not mandatory and is not designed to replace PDU/WDS. GDS 500E has limited functionality, when compared to PDU/WDS, but is smaller, faster and easier to use. The unit is equipped with a PROM that contains all operating and application software and therefore, does not require software application download before interfacing with vehicles. The PROM is serviceable, allowing for GDS 500E upgrading. The final upgrade PROM was made available in 2001. No further development of the GDS 500E will be made due to the release of its successor, the GDS 510.

GDS 500E is for use on 1995– 2001 MY Jaguar vehicles and includes the following capabilities on most vehicles:

OBDII Operations Menu

- Monitor powertrain data
- Monitor freeze frame data
- Request emissions trouble codes
- Clear emissions trouble codes
- Request oxygen sensor test results
- On-board monitoring system test results
- Control on-board system

JAGCOM Operations Menu (engine/transmission/ABS)

- Parameter monitor
- Stored codes
- Clear stored codes
- Diagnostic control

Note: While the final PROM upgrade was released in 2001, GDS 500E still retains limited functionality on later vehicles.

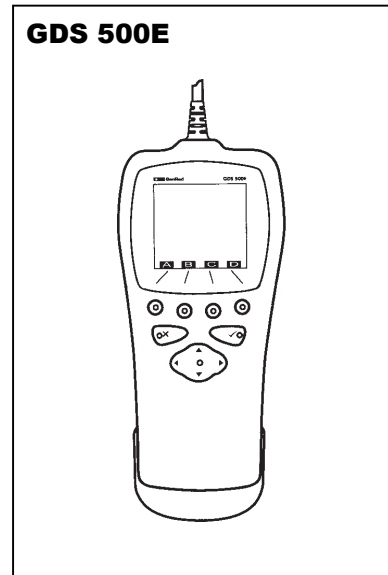

SEDAN MODELS



1995-1997

XJ6, Vanden Plas, XJR and XJ12 (1995/1996 only)

(X300-SWB, X330-LWB)

4.0 liter, 245 hp in-line 6 cyl eng. (except XJR and XJ12)

4.0 liter, 322 hp Supercharged in-line 6 cyl eng. (XJR only)

6.0 liter, 312 hp V-12 eng. (XJ12 only)

ZF 4HP24 4-spd automatic trans (XJ6, Vanden Plas)

GM 4L80E 4-spd automatic trans (XJ12 and XJR)



1998-2003

XJ8, Vanden Plas, and XJR

(X308-SWB, X338-LWB)

Normally aspirated 4.0 liter, 290 hp V8 eng. (XJ8)

Supercharged 4.0 liter, 370 hp V8 eng. (XJR)

ZF 5HP24 5-spd automatic trans (XJ8)

MB W5A580 5-spd automatic trans (XJR)

SEDAN MODELS



2000-2002

**S-Type
(X200)**

Normally aspirated 4.0 liter, 281 hp V8 eng.
Normally aspirated 3.0 liter, 240 hp V6 eng.
Ford 5R55N 5-spd automatic trans



2003

**S-Type, Type R
(X202)**

Normally aspirated 4.2 liter, 300 hp V8 eng.
Supercharged 4.2 liter, 400 hp V8 eng. (Type R only)
Normally aspirated 3.0 liter, 240 hp V6 eng.
ZF 6HP26 6-spd automatic trans (V6 or V8)
Getrag 221 5-spd manual trans (V6 only)



2002-2003

**X-Type
(X400)**

Normally aspirated 3.0 liter, 231 hp V6 eng.
Normally aspirated 2.5 liter, 194 hp V6 eng.
Ford MTX75 5-spd manual transaxle (AWD)
JATCO 5-spd automatic transaxle (AWD)

COUPE AND CONVERTIBLE MODELS



1995-1996

XJS and XJS Convertible

4.0 liter, 245 hp in-line 6 cyl eng. OR

6.0 liter, 312 hp V-12 eng. (1995 only)

ZF 4HP24 4-spd automatic trans (except 6.0 liter)

GM 4L80E 4-spd automatic trans (6.0 liter only)



1997- 2002

**XK8, XK8 Convertible, and
XKR (supercharged - 2000MY on)
(X100)**

Normally aspirated 4.0 liter, 290 hp V8 eng. (XK8)

Supercharged 4.0 liter, 370 hp V8 eng. (XKR)

ZF 5HP24 5-spd automatic trans (XK8)

MB W5A580 5-spd automatic trans (XKR)

VIN DECODER

2003 MODEL YEAR (MY) Shown

POSITION	DEFINITION	CHARACTERS
1-3	World Manufacturer ID	SAJ
4	Market/Airbags	F,G= Canada T,P = Mexico D,E= USA
5	Transmission/Steering	A = Automatic LHS B = Manual LHS
6-7	Vehicle Line/Body Type	01 = S-TYPE 4 Door Sedan 03 = S-TYPE SPORT 4 DR SEDAN 12 = XJ Sport 14 = XJ8 15 = XJR 24 = VDP 25 = Super V8 41 = XK8/XKR Coupe 42 = XK8/XKR Convertible 51 = X-TYPE 4 door sedan 52 = X-TYPE entry level 4 dr sedan 53 = X-TYPE Sport 4 dr sedan
8	Emission Control System	B = XKR,XJR/Super V8 B = Mexico 3.0 S-TYPE C = XJ8, XJ Sport, VDP, XK8, C = X-TYPE 3.0 C = Mexico 4.2 S-TYPE D = X-TYPE 2.5 D = Mexico S-TYPE R E = Mexico X-TYPE 2.5 F = Mexico X-type 3.0 G = Mexico V8 normally aspirated K = Mexico V8 S/C T = US/CANADA S-TYPE 3.0 U = US/CANADA S-TYPE 4.2 V = US/CANADA S-TYPE R
9	Check Digit	?
10	Model Year	3 = 2003 Model Year
11	Model Line & Assembly Plant	F = 3.0L S-TYPE V6; Castle Bromwich H = 4.2L S-TYPE V8; Castle Bromwich L = 4.0L Sedan; Browns Lane M = 4.0L S/C; Browns Lane 1 = 4.2L S-TYPE R; Castle Bromwich 2 = 4.2L XK8; Browns Lane 3 = 4.2 XKR S/C; Browns Lane W = 3.0L X-TYPE Halewood X = 2.5L X-TYPE Halewood

POSITION	DEFINITION	CHARACTERS
12	Model	A = XK8
		F = XJ Sedan, Super V8
		L, M, N =S-TYPE
		C, D = X-TYPE
13-17	Sequential	00001

INTRODUCTION TO JAGUAR

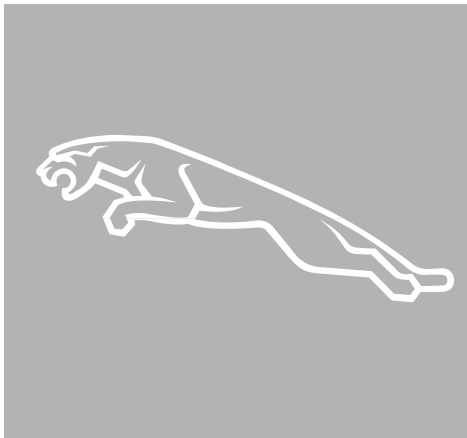

1 INTRODUCTION TO XJ/XK

1.1 Overview

- 1.2 Engine
- 1.3 Engine Management
- 1.4 Transmissions
- 1.5 Suspension, Steering and Brakes
- 1.6 Climate Control
- 1.7 Electrical Distribution System
- 1.8 Body Systems
- 1.9 Occupant Protection
- 1.10 Task Sheets



OVERVIEW

XJ General Information



Introduced in 1998 MY, the XJ V8 Series Sedan was available in four model variants; XJ8, XJ8L (long wheel base), XJR (supercharged) and Vanden Plas (long wheel base). A fifth variant, Super V8 (supercharged Vanden Plas) was added in 1999 MY. The XJ8 is a major update to the XJ6 Series Sedan it replaces. Although little externally changed, extensive changes are incorporated into the body structure to accommodate new power trains. Most systems were overhauled, with emphasis being placed on commonality with components and operation of the related systems in the XK8.

New engines providing improved performance, economy and refinement are combined with new transmissions providing improved shift quality and flexibility. These are complemented by the introduction of a new driveshaft and final drive unit. Handling and ride refinement are enhanced by upgraded braking and stability/traction control systems, variable ratio steering and extensive changes to the suspension, including an all-new front suspension. New electrical and multiplex communication systems are introduced to reduce the weight and complexity of vehicle harnesses.

Cabin interior remains the Classic or Sport theme, depending on model, while incorporating an all new fascia and revised model differentiation. A new center console and cubby box lid, restyled one-piece door casings, a restyled steering wheel center pad and a revised shift lever surround, further promotes interior freshening. Driver benefits include a new radio cassette with integrated phone controls and additional fore/aft seat travel.

Exterior freshening includes styling changes to the lamps, bumpers and headlamp powerwash jets, and the introduction of new wheel designs.

NOTES

XK General Information

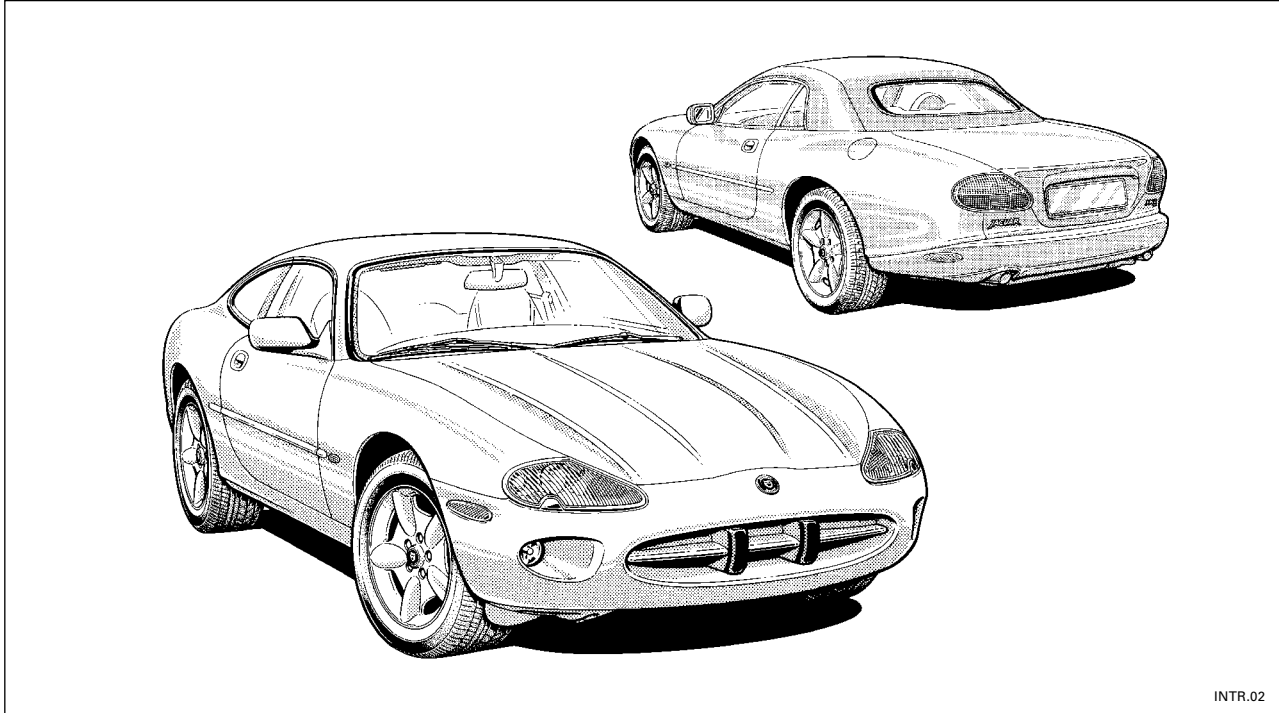

Introduced in 1997 MY, the XK8 luxury sports car is available in both coupe and convertible forms. It was the launch vehicle for the AJ-V8 engine and the ZF 5-speed transmission. The supercharged XKR variant was added to the model lineup in 2000 MY.

Interiors are trimmed in Sports or Classic style. Sports style follows the dark wood veneer and charcoal theme of the Sedan Sports models. The Classic style retains Jaguar's traditional burr walnut veneer and color coordinated trim.

Some features available (dependent on variant and MY):

- Speed sensitive, variable ratio, power steering system
- Adaptive damping
- Power latching convertible top
- Steering wheel mounted ICE and cruise control switches
- Telescopic headlamp power wash
- Four button remote transmitter
- Navigation
- Cellular phone
- Rain sensing windshield wipers
- Reverse parking aid

NOTES

OVERVIEW

XJ Vehicle Weights

Model	Kerb Weight (approximate)			Gross Vehicle Weight (approximate)		
	Front Axle	Rear Axle	Total	Front Axle	Rear Axle	Total
XJ8	923 kg (2035 lb.)	866 kg (1910 lb.)	1789 kg (3945 lb.)	1016 kg (2240 lb.)	1202 kg (2650 lb.)	2218 kg (4890 lb.)
XJ8 L	924 kg (2038 lb.)	885 kg (1952 lb.)	1810 kg (3990 lb.)	1018 kg (2245 lb.)	1222 kg (2695 lb.)	2240 kg (4940 lb.)
XJR	960 kg (2117 lb.)	888 kg (1958 lb.)	1848 kg (4075 lb.)	1055 kg (2325 lb.)	1215 kg (2680 lb.)	2270 kg (5005 lb.)
VOIDS	941 kg (2075 lb.)	873 kg (1925 lb.)	1814 kg (4000 lb.)	1036 kg (2285 lb.)	1209 kg (2665 lb.)	2245 kg (4950 lb.)
Super V8						

NOTE: The above weights are for vehicles without a towbar. The addition of a towbar increases the total weight by 25 kg (55 lb.), with the front axle load decreasing by approximately 8.5 kg (19 lb.) and the rear axle load increasing by approximately 33.5 kg (74 lb.).

The gross vehicle weight can be increased by a maximum of 100 kg provided the tire pressures are at Normal pressure and vehicle speed does not exceed 100 km/h (62.5 mph).

XJ Dimensions

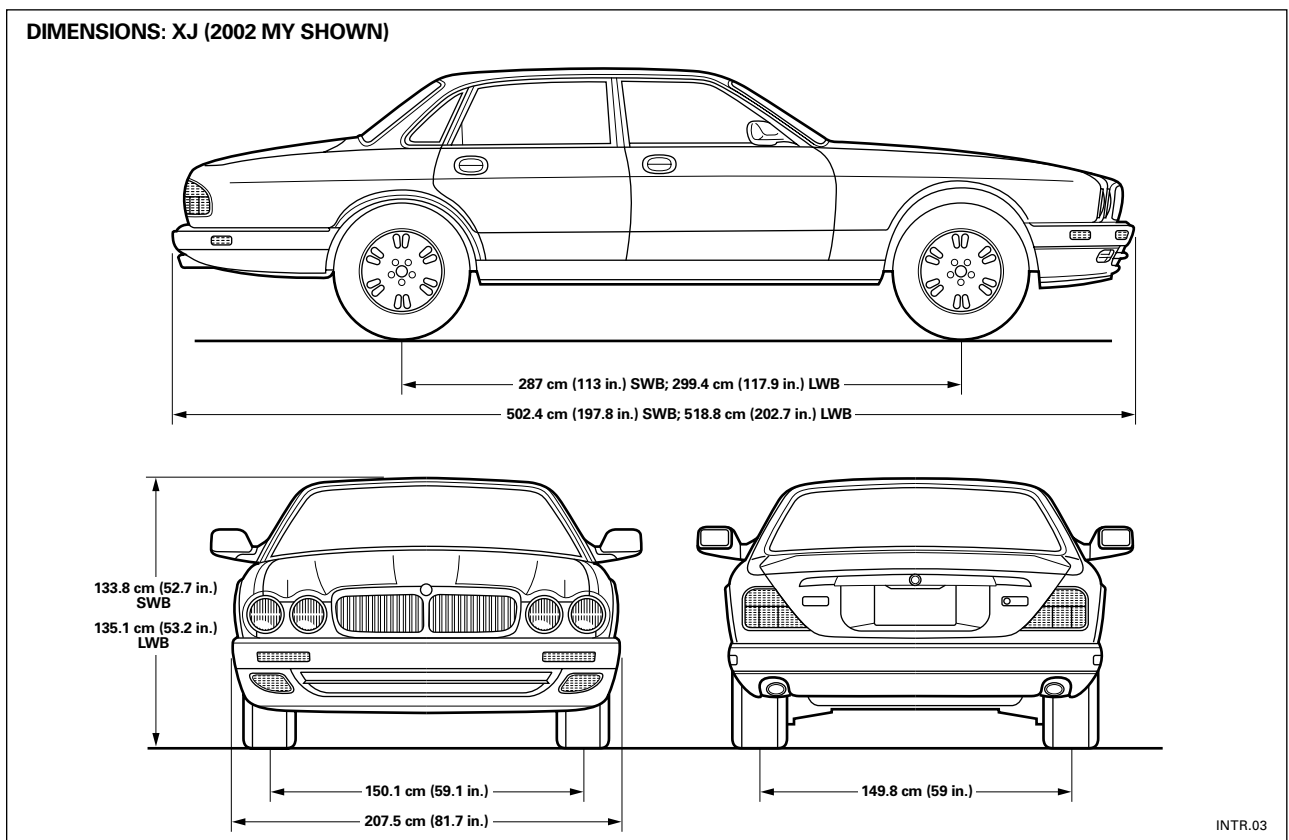

XK Vehicle Weights

Model	Kerb Weight (approximate)			Gross Vehicle Weight (approximate)		
	Front Axle	Rear Axle	Total	Front Axle	Rear Axle	Total
XK8 Coupe	842 kg (1852 lb.)	773 kg (1700 lb.)	1615 kg (3553 lb.)	953 kg (2100 lb.)	1057 kg (2330 lb.)	2010 kg (4431 lb.)
XK8 Convertible	877 kg (1929 lb.)	828 kg (1821 lb.)	1705 kg (3751 lb.)	983 kg (2167 lb.)	1117 kg (2463 lb.)	2100 kg (4630 lb.)
XKR Coupe			1717 kg (3785 lb.)			
XKR Convertible			1824 kg (4021 lb.)			

NOTE: The maximum permitted trunk capacity (with driver and passenger) is 48 kg (106 lb.).

XK Dimensions

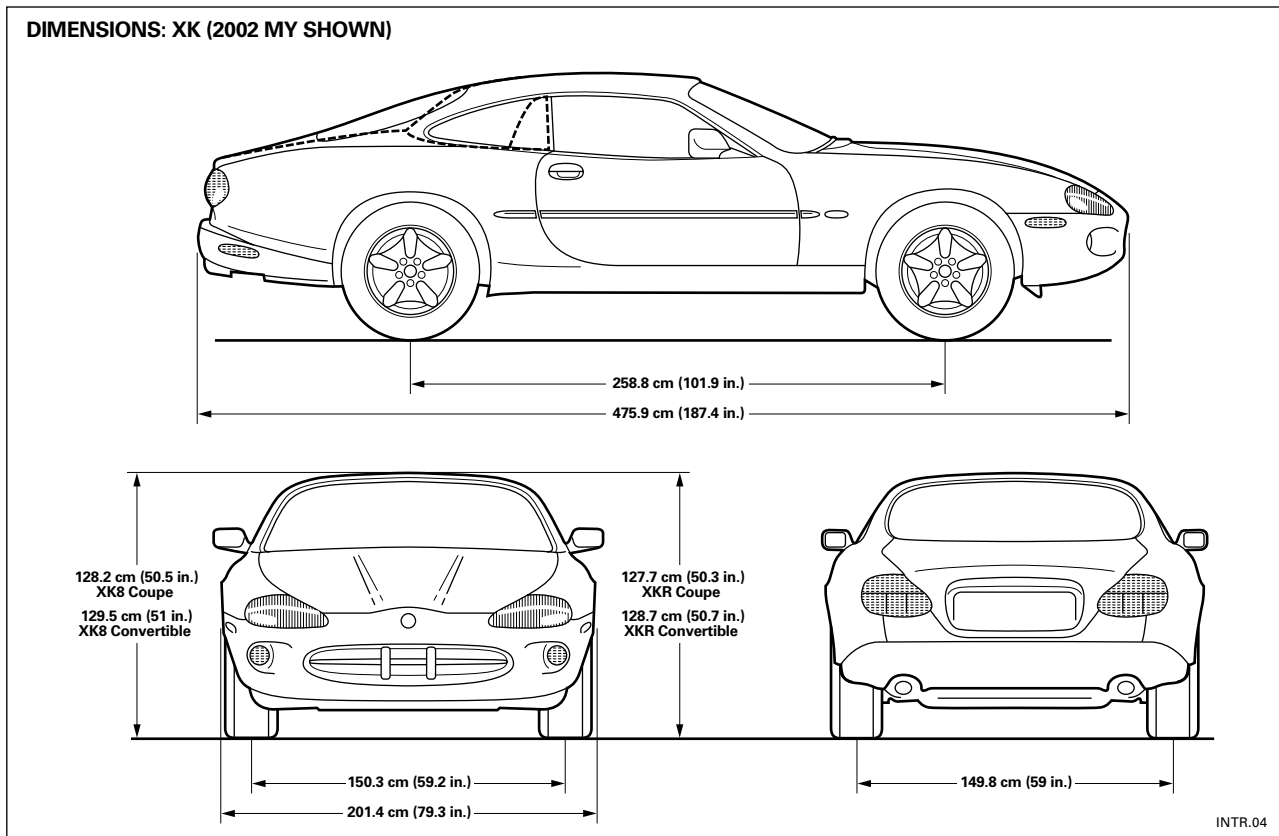

NOTES

INTRODUCTION TO XJ/XK

OVERVIEW

Vehicle Identification Numbers (VIN)

IDENTIFICATION PLATE AND LABEL LOCATION: XJ

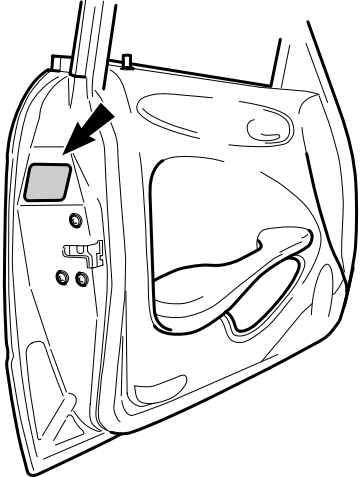

**MFD BY JAGUAR CARS LTD
COVENTRY ENGLAND**

MFD DATE GVWR

GAWR F R

THIS VEHICLE CONFORMS TO ALL APPLICABLE FEDERAL MOTOR VEHICLE SAFETY BUMPER AND THEFT PREVENTION STANDARDS IN EFFECT ON THE DATE OF MANUFACTURE SHOWN BELOW

VEH IDENT NO.

TYPE PASSENGER CAR

PAINT TRIM

NORTH AMERICA

JAGUAR CARS LTD

MFD DATE GVWR

GAWR /PNBE F/AV R/AR

VEH IDENT NO.

TYPE PC/VT

PAINT

TRIM



CANADA

INTR.06

XJ Identification Plates and Labels

VIN (vehicle identification number) and other information is displayed on a label located on the rear edge of the LH front door. For certain markets, the VIN appears on a bar code label referred to as the Certification Label and additionally carries the month and year of manufacture, vehicle weight data and paint codes. The VIN is also displayed on a plate that is visible through the windshield. It is essential that the VIN is quoted when ordering parts, and in all associated correspondence.

XK Identification Plates and Labels

The Vehicle Identification Number (VIN) is stamped on the right-hand side longitudinal member of the spare wheel compartment.

A clear patch in the darkened area at the bottom left of the windshield allows visible access to a VIN plate which is bonded to the windshield reinforcing lower panel.

The VIN identification label is fixed to the B-post on the left-hand side of the vehicle, above the door striker plate. For Canada markets the VIN label is similar to that for the USA market and in the same location.

For the USA markets, an emissions bar code label is adhered to the drivers door shut face. The E approval label is fixed to the top surface of the LH turret panel.

IDENTIFICATION PLATE AND LABEL LOCATION: XK

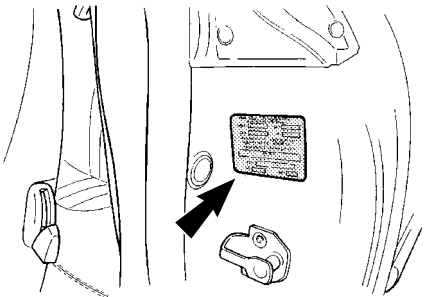

JAGUAR CARS LTD

Kg

Kg

Kg

Kg

1

2

PAINT TRIM

**ALL MARKETS EXCEPT USA,
CANADA AND SAUDI ARABIA**

**MFD BY JAGUAR CARS LTD
COVENTRY ENGLAND**

MFD DATE GVWR

GAWR F R

THIS VEHICLE CONFORMS TO ALL FEDERAL MOTOR VEHICLE SAFETY BUMPER AND THEFT PREVENTION STANDARDS IN EFFECT ON THE DATE OF MANUFACTURE SHOWN ABOVE

VEH IDENT NO.

TYPE

PAINT TRIM

USA MARKETS

INTR.05

NOTES

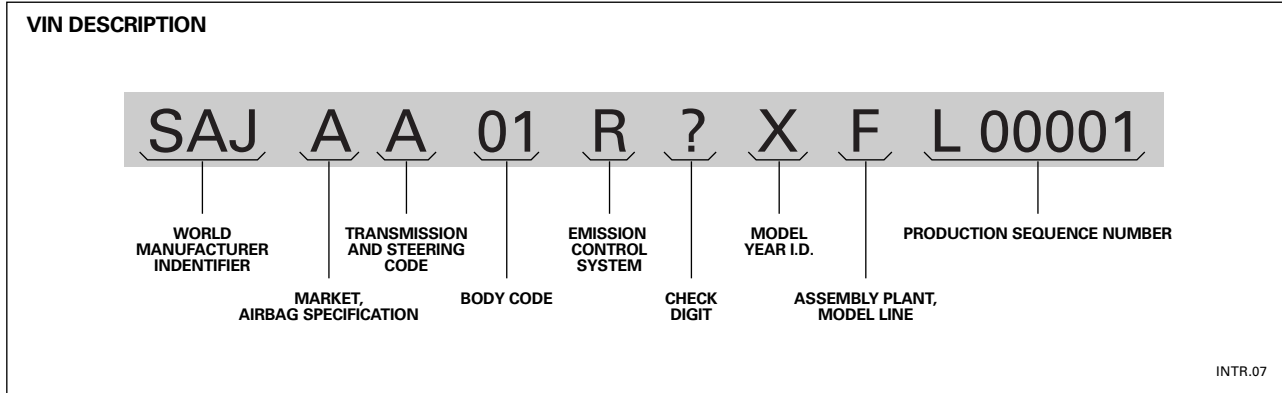

Production Sequence Numbers

XJ Models XJ8, XJ8 L, XJR, VDP, Super V8

XK Models XK8 Coupe, XK8 Convertible, XKR Coupe, XKR Convertible

Model Year	Production Sequence Numbers	
	XJ Models	XK Models
1997 (Model year I.D. "V")	—	001001 – 018107
1998 (Model year I.D. "W")	812256 – 853935	018108 – 031302
1999 (Model year I.D. "X")	853936 – 878717	031303 – 042775
2000 (Model year I.D. "Y")	F00001 – F20644	A00001 – A11050
2001 (Model year I.D. "1")	F20645 – F40031	A11051 – A22928
2002 (Model year I.D. "2")	F40032 –	A22929 –

NOTES

OVERVIEW

Vehicle Jacking and Towing

CAUTION: Do not use the aluminum suspension cross beam for jacking the front of the car. Use only the car jacking points or the steel cross member below the radiator package.

Rear jacking points are the normal car jacking points or the rear of the rear suspension sub-frame.

Road and ship transportation lashdown for the rear of the vehicle is via the rear suspension reinforcement forward of the rear wheels. Slave towing/lashing eyes are provided for road or ship lashdown of the front of the vehicle.

CAUTION: The slave towing/lashing eyes must be removed before the vehicle is driven on the public highway.

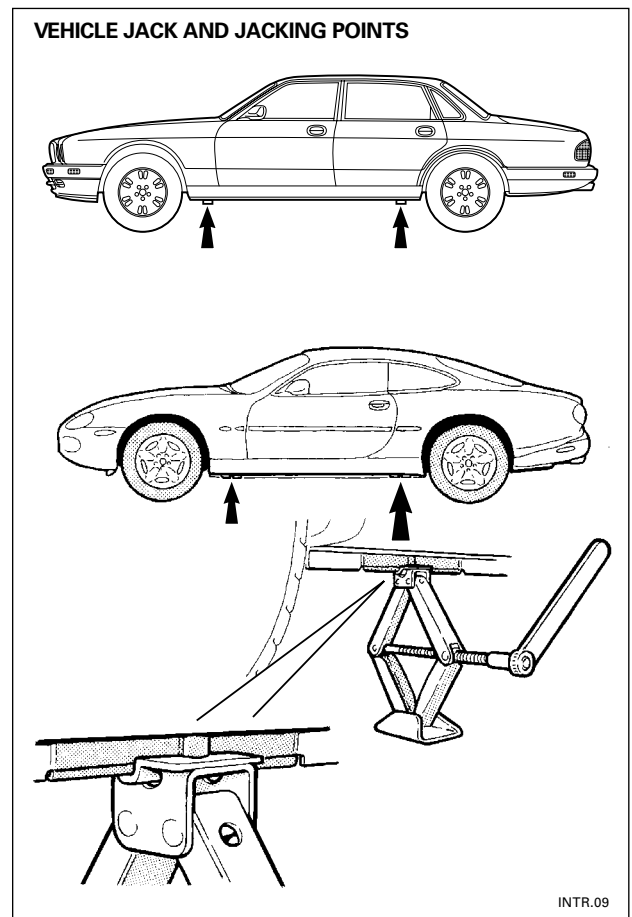
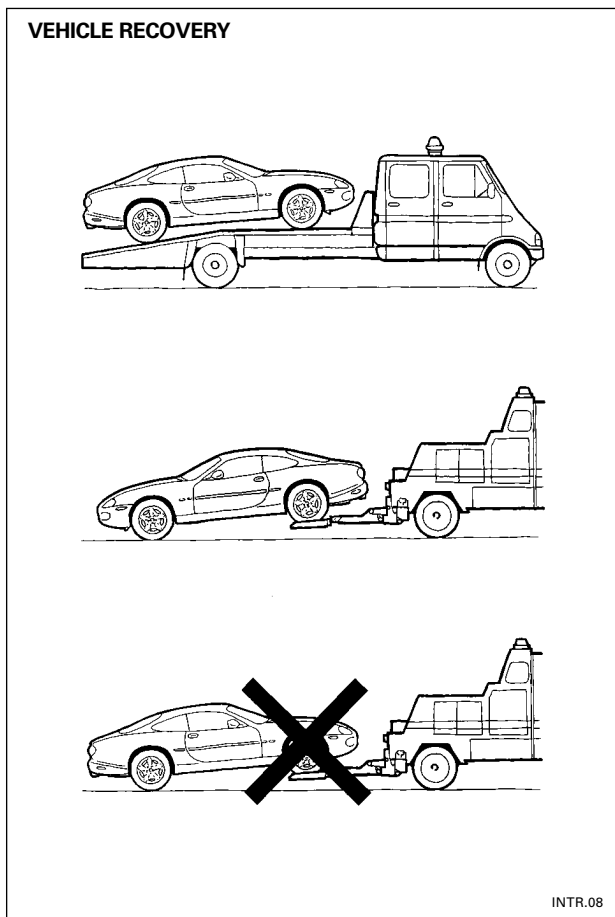

NOTES

For vehicle recovery, a single front towing eye, stowed in the trunk, screws into either the left or right-hand side of the lower cross member. The rear towing eye is a welded double loop on the right-hand side corner of the luggage floor.

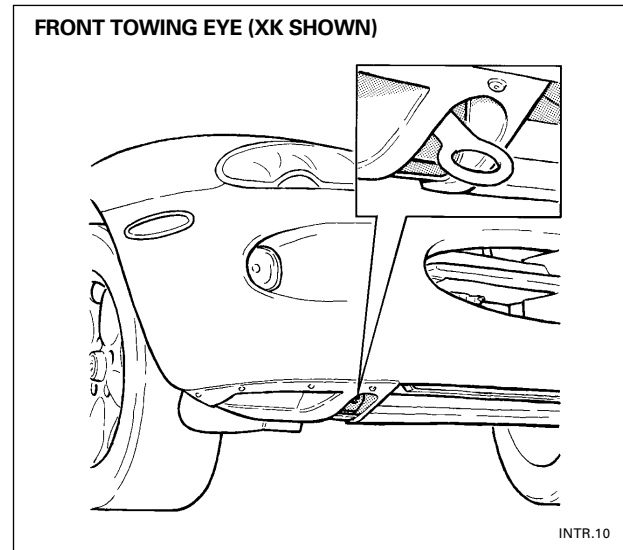

NOTES

INTRODUCTION TO JAGUAR

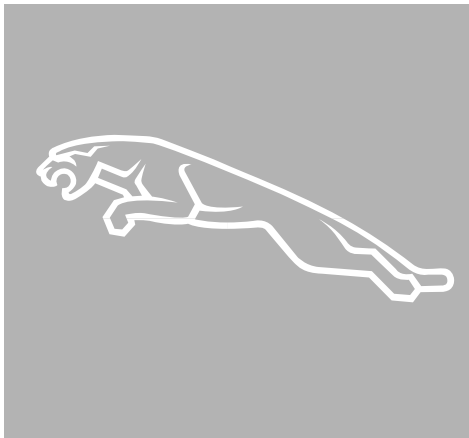

1 INTRODUCTION TO XJ/XK

1.1 Overview

1.2 Engine

1.3 Engine Management

1.4 Transmissions

1.5 Suspension, Steering and Brakes

1.6 Climate Control

1.7 Electrical Distribution System

1.8 Body Systems

1.9 Occupant Protection

1.10 Task Sheets

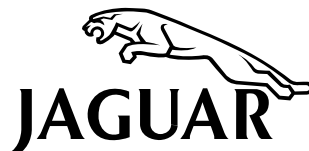

ENGINE

4.0 LITER AJ-V8 ENGINE

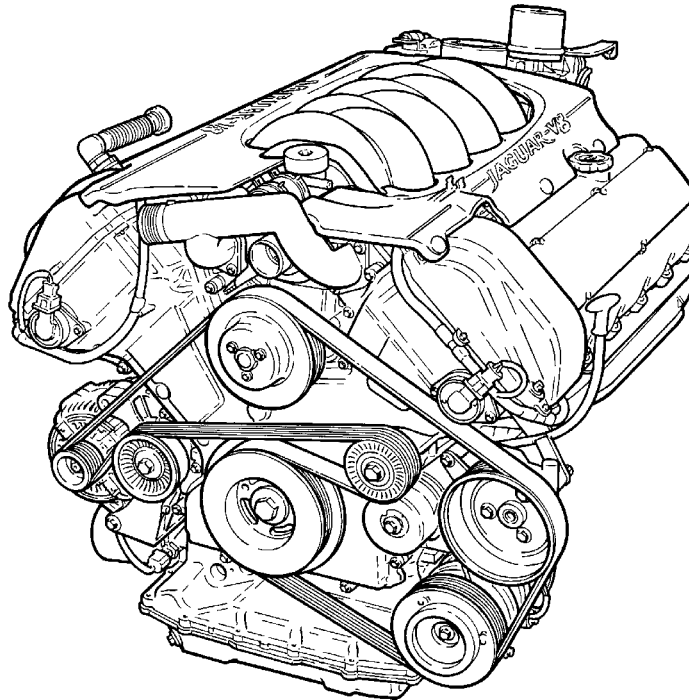

INTR.11

The AJ-V8 4.0 liter engine is the first V8 to be offered by Jaguar. Designed to give excellent performance, refinement, economy, and low vibration levels it also conforms to the strictest emission legislation. The AJ-V8 is available in both normally aspirated and supercharged versions. The engine is shorter by 12 inches (300 mm) than the AJ16 4.0 liter engine it replaced. Compression ratio is 10.75:1 (N/A) and 9.0:1 (SC), with four valves per cylinder. The cylinder head heads, block, and bedplate are cast aluminum. Normally aspirated variants are equipped with variable valve timing to give improved low and high-speed engine performance and excellent idle quality. Airflow into the normally aspirated engine is through a one-piece composite intake manifold via an electronic throttle assembly. The intake manifold is replaced with dual charge air coolers on the supercharged variant. The engine has a low volume, high velocity, cooling system which achieves a very fast warm-up with reduced and even metal temperatures in the combustion chamber and increased bore temperatures.

The generator, A/C compressor, and PAS are mounted to the block on rigid cradle supports. Accessory drive is from a single, 7-ribbed vee belt. Hydraulic engine mounts minimize noise and vibration.

NOTES

Engine Specifications

	4.0 Liter N/A	4.0 Liter SC
Configuration	90° V8	90° V8
Cylinder Head	Dual overhead camshafts, 4 valves per cylinder	Dual overhead camshafts, 4 valves per cylinder
Valve Clearances (Cold): Intake Exhaust	0.18 to 0.22 mm 0.23 to 0.27 mm	0.18 to 0.22 mm 0.23 to 0.27 mm
Firing Order	1A, 1B, 4A, 2A, 2B, 3A, 3B, 4B	1A, 1B, 4A, 2A, 2B, 3A, 3B, 4B
Bore	86 mm (3.386 in)	86 mm (3.386 in)
Stroke	86 mm (3.386 in)	86 mm (3.386 in)
Displacement	3.996 liters (244 in ³)	3.996 liters (244 in ³)
Compression Ratio	10.75 : 1	9.00 : 1
Maximum Power (DIN)	216 kW (290 BHP) at 6100 rpm	276 kW (370 BHP) at 6150 rpm
Maximum Torque (DIN)	393 Nm (290 lb ft) at 4250 rpm	525 Nm (387 lb ft) at 3600 rpm
Maximum Speed (limited)	6950 rpm	6200 rpm
Coolant Volume (complete system)	10 liters (2.65 gal)	12 liters (3.17 gal)
Weight (approximate, with accessories)	200 kg (441 lb)	227 kg (500 lb)

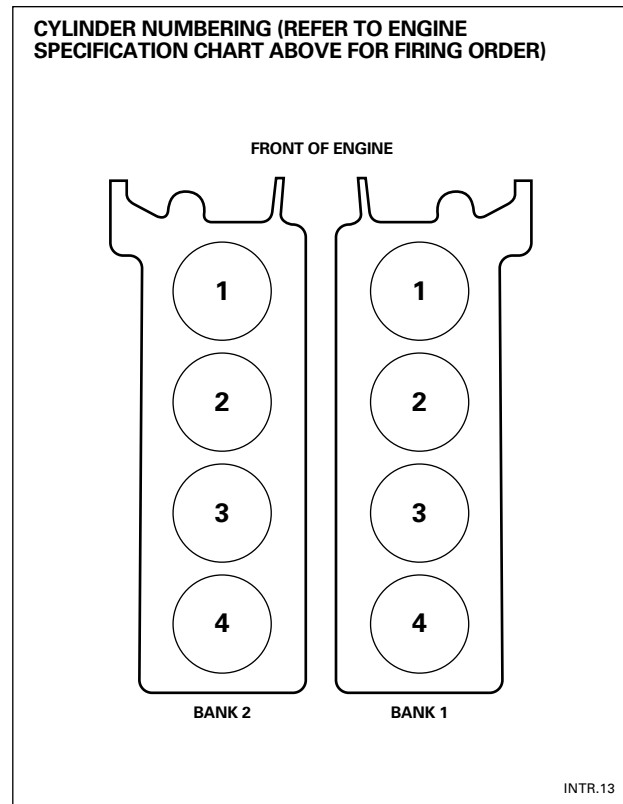
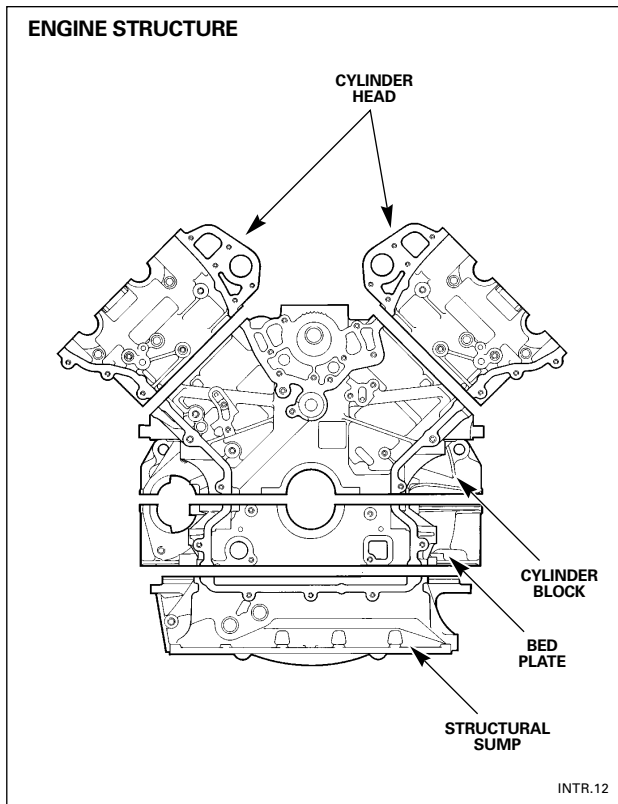

ENGINE

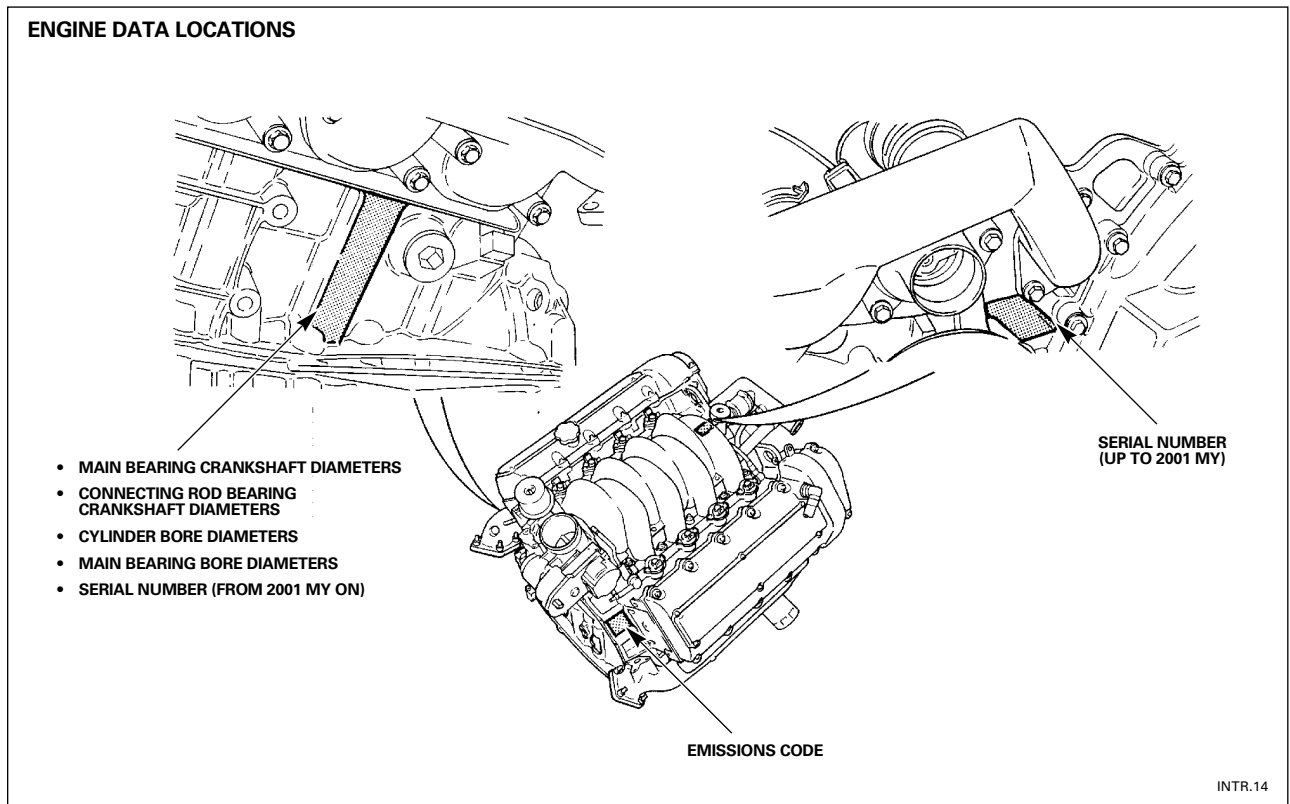

NOTES

INTRODUCTION TO JAGUAR

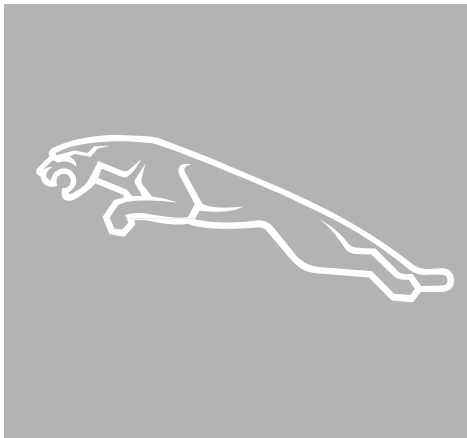

1 INTRODUCTION TO XJ/XK

1.1 Overview

1.2 Engine

1.3 Engine Management

1.4 Transmissions

1.5 Suspension, Steering and Brakes

1.6 Climate Control

1.7 Electrical Distribution System

1.8 Body Systems

1.9 Occupant Protection

1.10 Task Sheets



ENGINE MANAGEMENT

AJ26 / AJ27 EMS Overview

The AJ26 engine management system was designed for the introduction of the V8 engine to the Jaguar range of vehicles starting with the 1997 model year XK8. A supercharged version was added for 1998 model year.

The AJ27 engine management system is a further development of the AJ26 system designed to meet more stringent emission control standards and enhance engine performance. The naturally aspirated AJ27 system was introduced for the 1999 model year; the supercharged AJ27 system was introduced for the 2000 model year.

System application is as follows:

Engine Management System	Model Year	Models
AJ26	1997	XK N/A
	1998	XK & XJ N/A
	1999	XJR (SC)
AJ27	1999	XK & XJ N/A
	2000	XK & XJ N/A and SC
	2001	XK & XJ N/A and SC
	2002	XK & XJ N/A and SC

Both systems are built around a two-microprocessor based Engine Control Module (ECM). The ECM is linked to and communicates with other powertrain control modules and other vehicle systems via the Controller Area Network (CAN).

The ECM governs all engine operating functions including:

- Air induction via an electronically controlled throttle
- Fuel delivery
- Sequential fuel injection
- Ignition via on-plug ignition coils
- Idle speed control
- Exhaust emission control
- Evaporative emission control
- Intake valve timing
- Exhaust gas recirculation (certain variants only)
- Cooling system radiator fan control
- Air conditioning compressor control
- Cruise control
- Engine speed limiting
- Engine torque reduction to aid transmission shift quality and enhance traction / stability control
- EMS and OBD II diagnostics
- Default operating modes including engine speed and throttle limits

NOTES

System Variant Summary (North American specification vehicles):

FUNCTION	AJ26 N/A	AJ26 SC	AJ27 N/A	AJ27 SC
Electronically controlled throttle <ul style="list-style-type: none"> Electronically controlled throttle with mechanical guard Full authority electronically controlled throttle 	X	X	X	X
Variable valve timing <ul style="list-style-type: none"> Two position variable intake valve timing Linear variable intake valve timing 	X		X	
Exhaust gas recirculation	X *	X		X
Oxygen sensors <ul style="list-style-type: none"> Upstream HO2S; downstream O2S Upstream Universal HO2S; downstream HO2S 	X	X	X	X
Ignition coils <ul style="list-style-type: none"> A Bank / B Bank ignition coil modules Individual integral ignition coil modules 	X	X	X	X
Security engine management immobilization	X **	X	X	X
On-board refueling vapor recovery	X ***	X	X ***	X
Air assisted fuel injection			X	
DTC memory <ul style="list-style-type: none"> DTCs and system adaption stored in volatile memory DTCs and system adaption stored in non-volatile memory 	X	X	X	X

* Early production only. EGR deleted on normally aspirated engine as a running change during 1997.

** Key transponder security input and diagnostic introduced for 1998 model year.

*** On-board refueling vapor recovery (ORVR) introduced for 1998 model year XJ8, 1999 model year XK8.

NOTES

ENGINE MANAGEMENT

Control Summaries

The AJ26 and AJ27 engine management systems are comprehensive engine control systems that allow complete electronic control over all engine functions. The following pages provide control summaries for the four system variants. Specific pin-out data can be found in the applicable Electrical Guide.

System Logic: AJ26 N/A

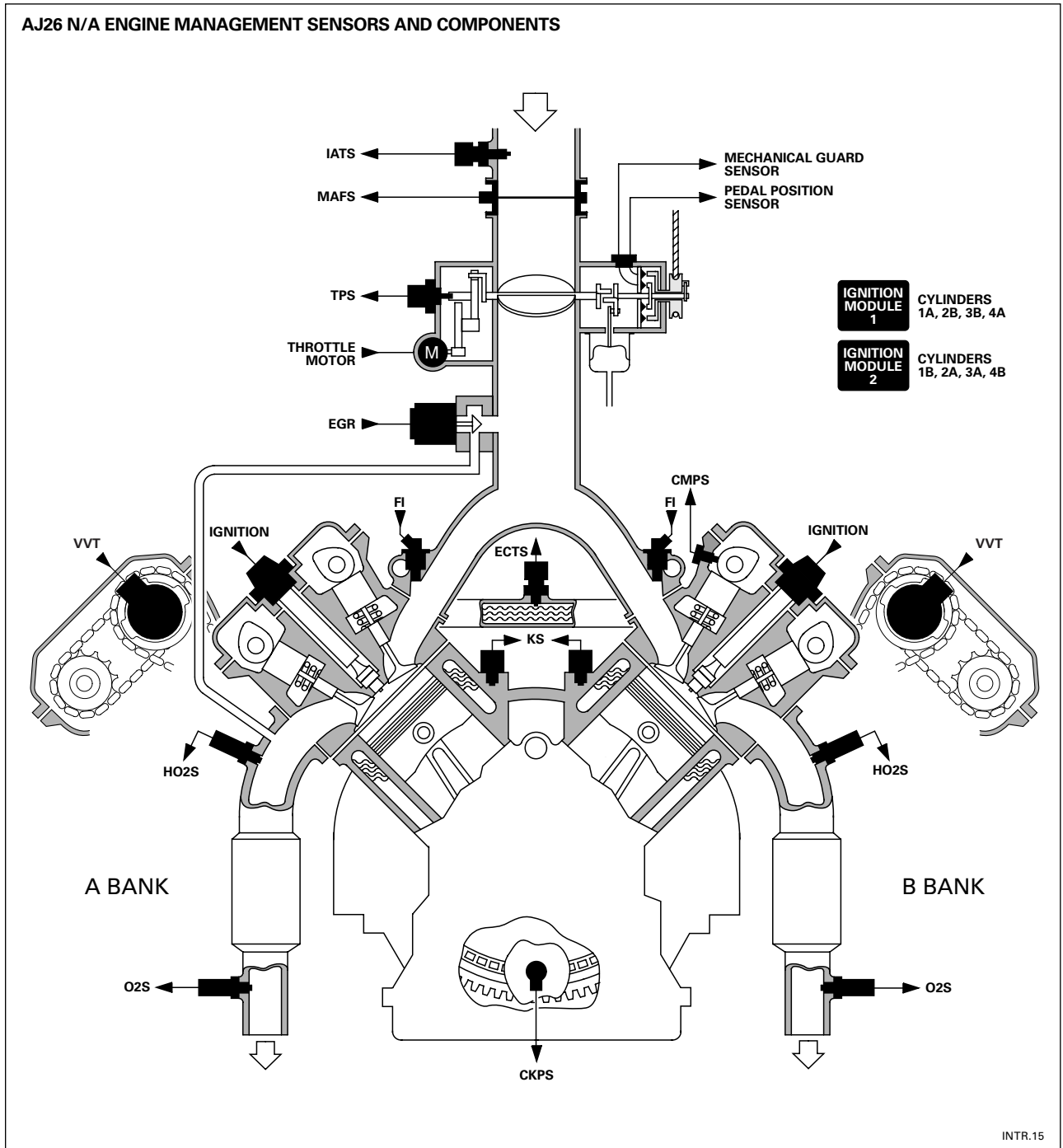

System Logic: AJ26 SC

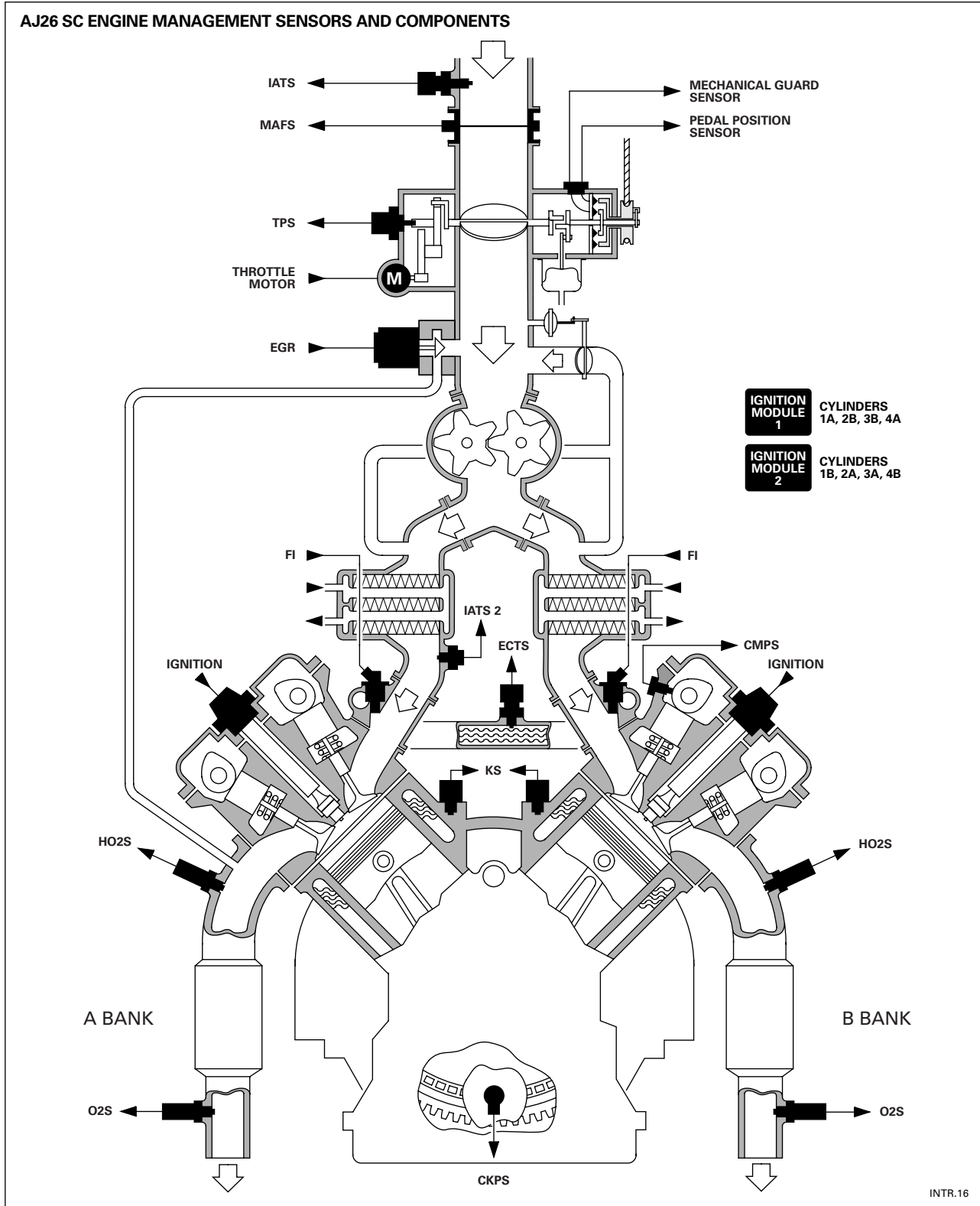

INTR.16

ENGINE MANAGEMENT

Control Summaries (continued)

System Logic: AJ27 N/A

AJ27 N/A ENGINE MANAGEMENT SENSORS AND COMPONENTS

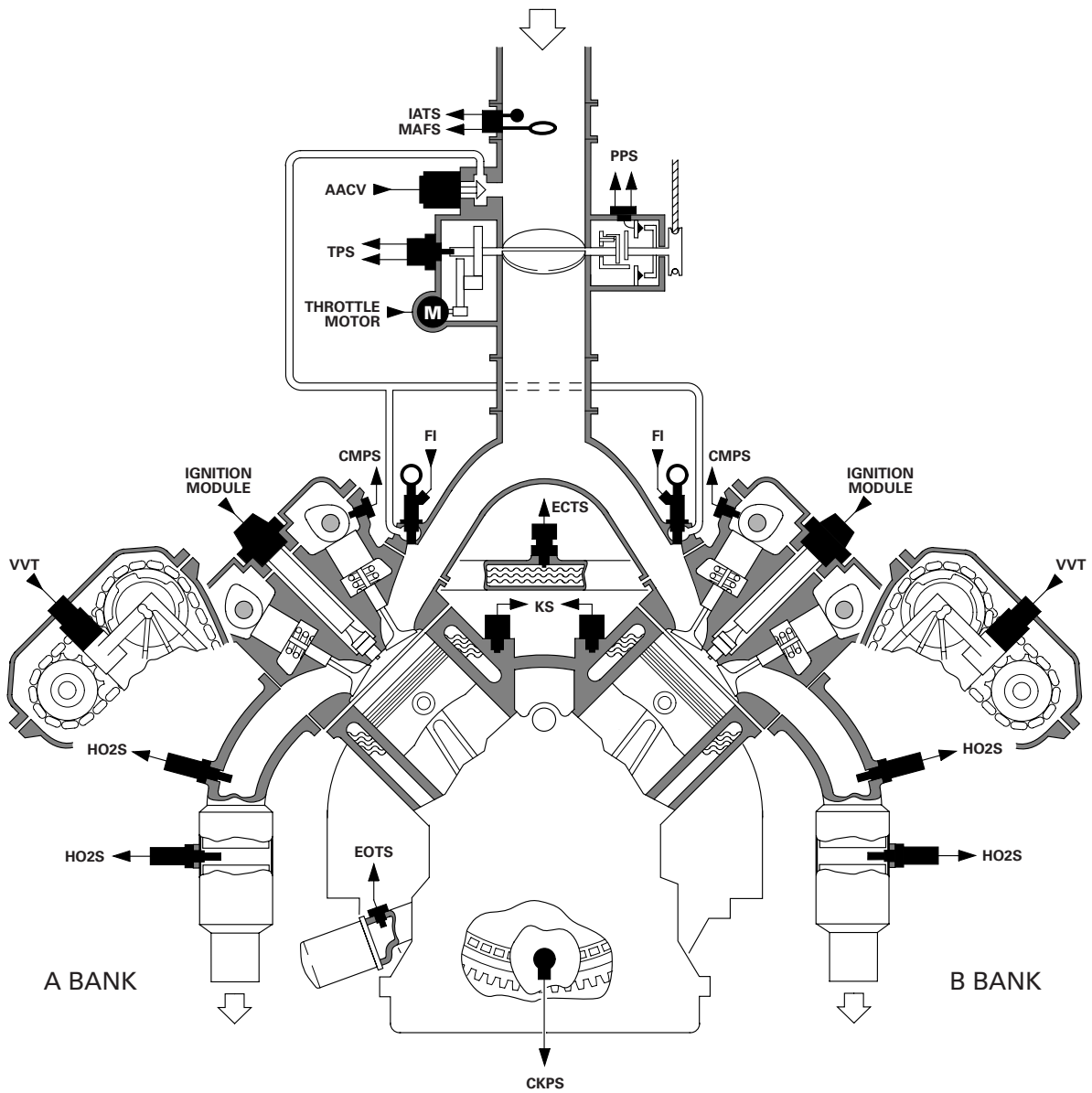

INTR.17

System Logic: AJ27 SC

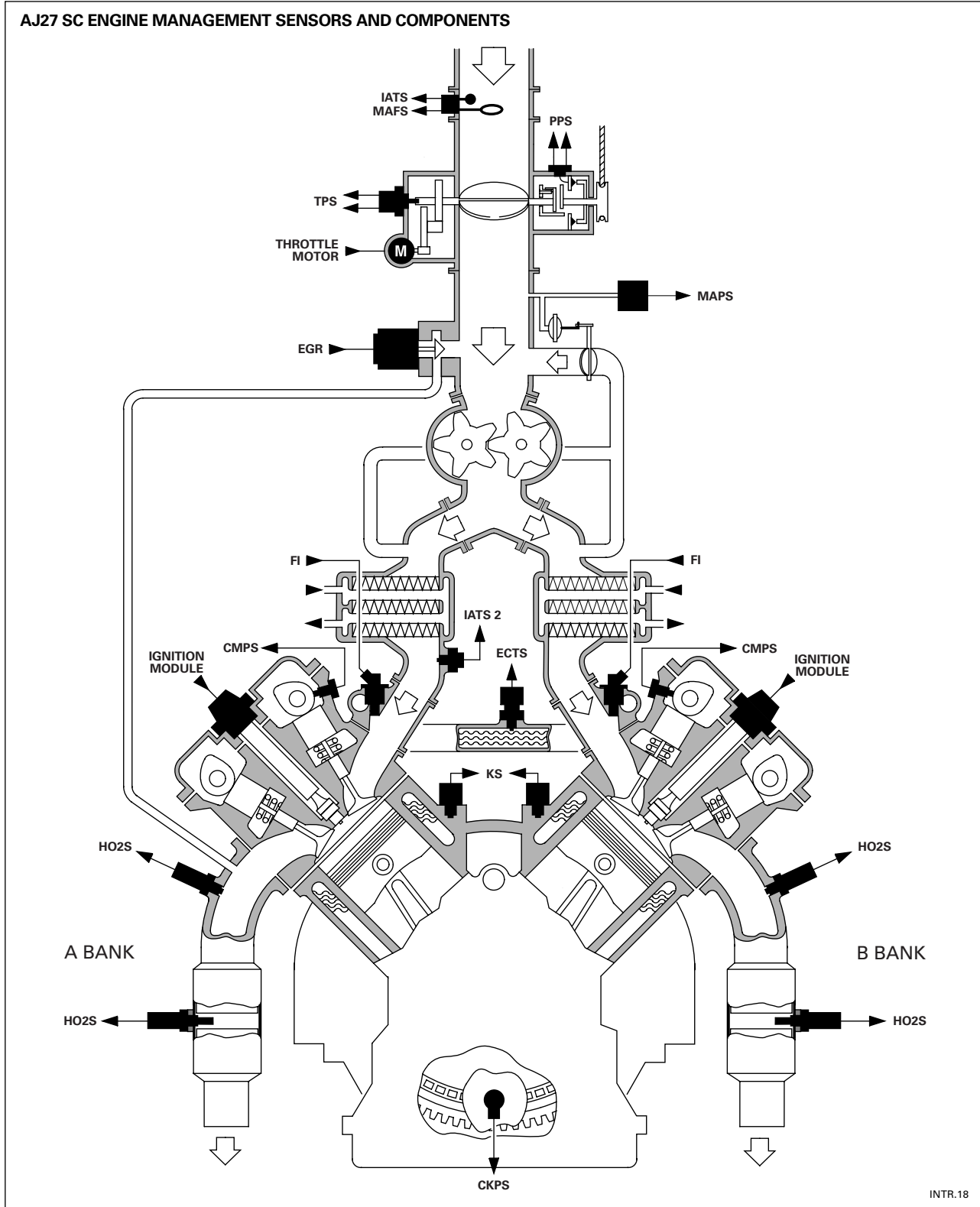

INTRODUCTION TO JAGUAR

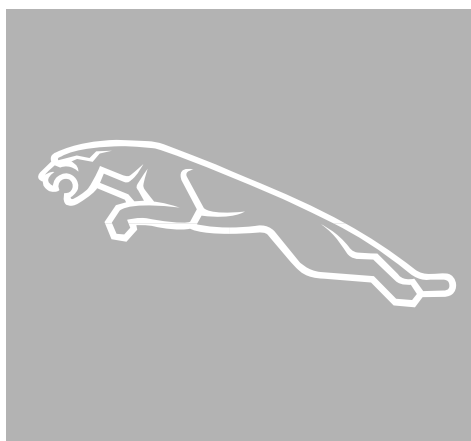

1 INTRODUCTION TO XJ/XK

- 1.1 Overview
- 1.2 Engine
- 1.3 Engine Management

1.4 Transmissions

- 1.5 Suspension, Steering and Brakes
- 1.6 Climate Control
- 1.7 Electrical Distribution System
- 1.8 Body Systems
- 1.9 Occupant Protection
- 1.10 Task Sheets

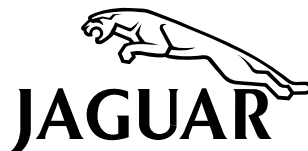

TRANSMISSIONS

5HP 24 Automatic Transmission System

Overview

Normally aspirated V8 XJ and XK vehicles are equipped with the 5HP 24 five-speed automatic transmission system.

The transmission and most of the vehicle interface components are mechanically identical for both vehicles. The transmission is TCM (transmission control module) controlled. The TCM communicates with the engine management system, ABS/TC system and the instrument pack via the high speed Controller Area Network (CAN).

Gear selection occurs via the Jaguar style J-gate gear selector assembly that features fully automatic shifting (Drive) on the right hand side and driver controlled semi-manual shifting on the left hand side (4th, 3rd, 2nd). Normal and Sport transmission operating modes are selected by the driver via the mode switch located near the J-gate.

5HP 24 TRANSMISSION

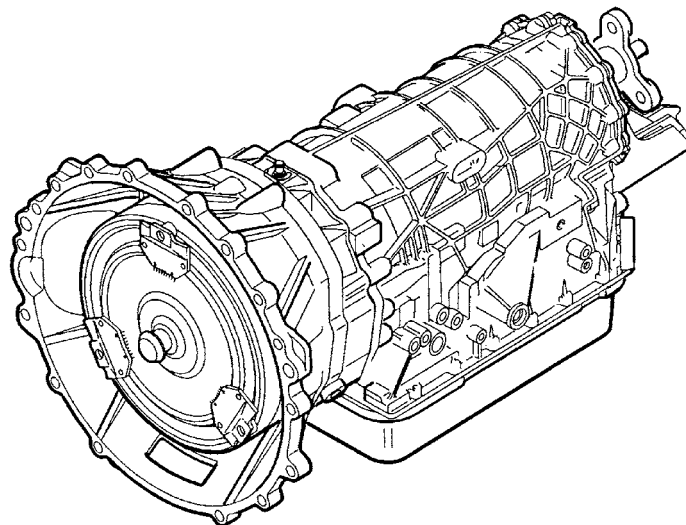

INTR.19

NOTES

Specifications

Transmission weight: 95 kg (210 lb.) with torque converter and fluid.

Mechanical features: Transmission case in three sections – torque converter housing, main case and rear extension housing.
Torque converter with single plate controlled slip lock-up clutch
Planetary gear train (no brake bands)

Gear ratios	1st	2nd	3rd	4th	5th	Rev
	3.57 : 1	2.20 : 1	1.51 : 1	1.00 : 1	0.80 : 1	4.10 : 1

Transmission fluid: Capacity – 10 liters (10.6 quarts)
Fill / change – “Filled for life” (Refer to Maintenance Schedule and JTIS.)
Type – Esso LT
Jaguar Part Number JLM 20237 (1 liter)

Transmission fluid cooler: External liquid-to-liquid cooler integral with the left hand side radiator tank.

Stall Test: There is no stall test specification for the 5HP 24 transmission.

NOTES

TRANSMISSIONS

5HP 24 Automatic Transmission System (continued)

Transmission Control

The 5HP 24 automatic transmission system is fully controlled by the transmission control module (TCM) located in the engine compartment “cool box” along with the engine control module (ECM).

A high speed controller area network (CAN) allows communication between the TCM, ECM, ABS/TC CM, and the instrument pack.

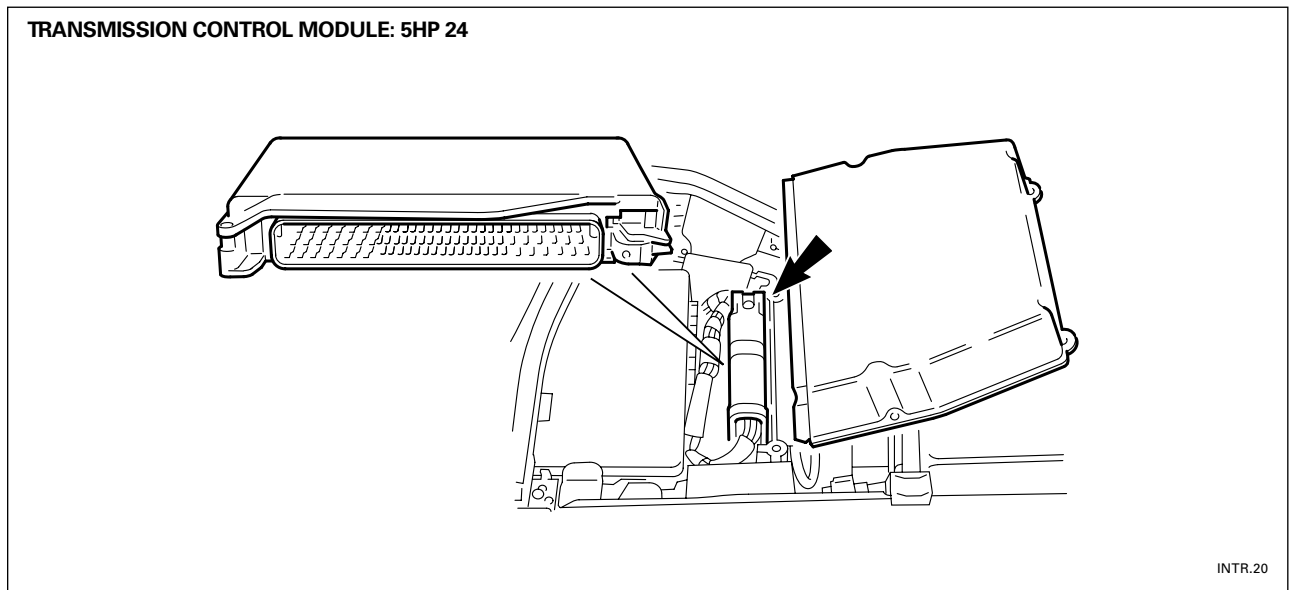

TCM volatile memory

Adaptive values and DTCs are stored in TCM volatile memory. If the vehicle battery is disconnected, all TCM stored adaptive values DTCs will be lost. The TCM will relearn the adaptive values during the next driving cycle.

NOTES

INTRODUCTION TO XJ/XK

5HP 24 TCM control incorporates the following control features:

- Normal / Sport operational modes
- Shift scheduling / shift feel strategy
- Closed loop shift control
- Controlled overlap shifting
- Adaptive pressure control to account for component aging and operating conditions
- Specific driving conditions shift strategies
 - Traction control active
 - Engine / transmission over-temperature (hot mode)
 - Gradient
 - Cruise control
 - Hot mode
 - Manual shift (M 2, 3, 4)
- Torque converter clutch on, off and controlled slip
- Shift energy management (engine torque modulation during shift)
- Engine torque reduction during “transmission failure”, Reverse
- On board diagnostics (OBD II and non OBD II)
- Component failure default modes (mechanical and electronic “limp home”)

NOTES

TRANSMISSIONS

W5A 580 Automatic Transmission System

Overview

Supercharged V8 XJ and XK vehicles are equipped with the W5A 580 five-speed automatic transmission system.

The transmission and most of the vehicle interface components are mechanically identical for both vehicles. The transmission is TCM (transmission control module) controlled. The TCM communicates with the engine management system, ABS/TC system and the instrument pack via the high speed Controller Area Network (CAN).

Gear selection occurs via the Jaguar style J-gate gear selector assembly that features fully automatic shifting (Drive) on the right hand side and driver controlled semi-manual shifting on the left hand side (4th, 3rd, 2nd). Normal and Sport transmission operating modes are selected by the driver via the mode switch located near the J-gate.

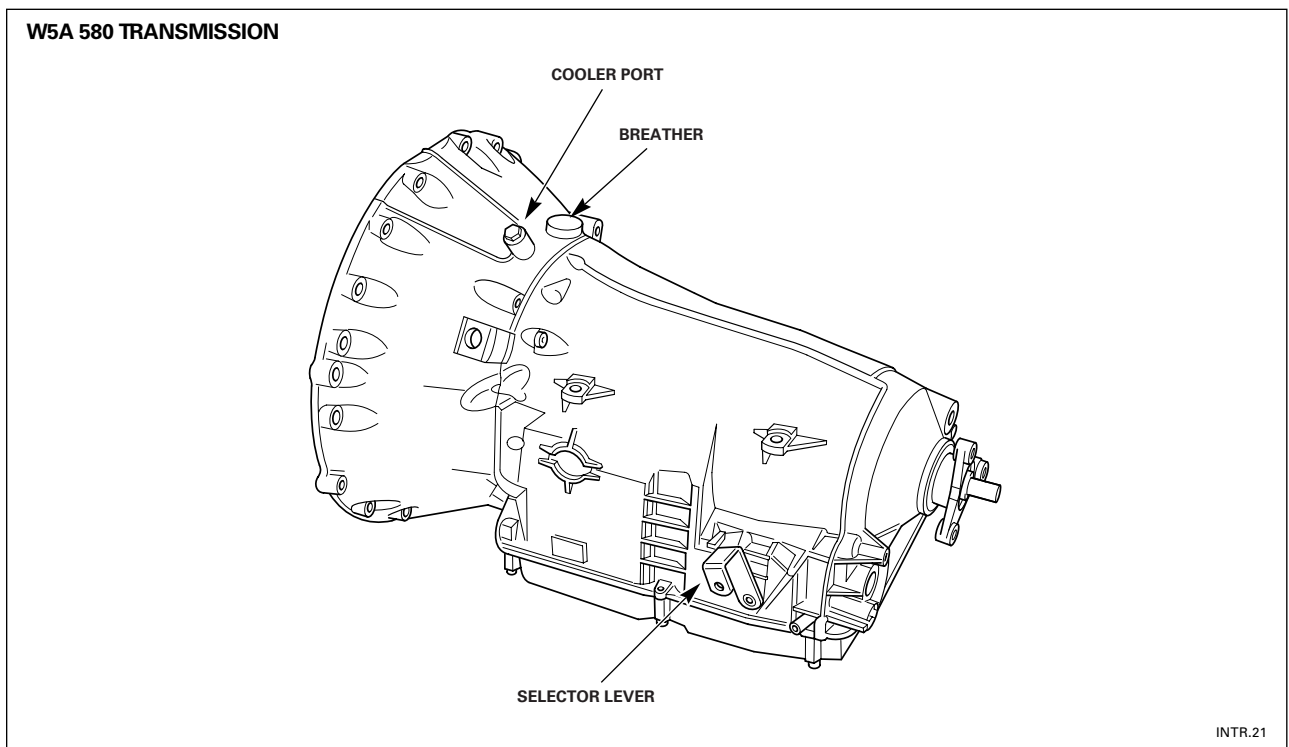

NOTES

Specifications

Transmission weight:	81 kg (179 lb.) with torque converter						
Mechanical features:	Transmission case in two sections – torque converter housing and main case Torque converter with two-plate controlled slip lock-up clutch Planetary gear train (no brake bands)						
Gear ratios:	1st	2nd	3rd	4th	5th	Rev (Norm.)	Rev (Sport)
	3.59 : 1	2.19 : 1	1.41 : 1	1.00 : 1	0.83 : 1	1.93 : 1	3.16 : 1
Transmission fluid:	Capacity – 9.4 liters (10 quarts) Fill / change – “Filled for life” (Refer to Maintenance Schedule and JTIS.) Type – Shell LA Jaguar Part Number JLM 20292 (1 liter)						
Transmission fluid cooler:	External liquid-to-liquid cooler integral with the left hand side radiator tank.						
Towing:	Maximum 50 km (30 mi.) at less than 50 km/h (30 mph)						
Stall Test:	Due to throttle limitation at low vehicle speed, a stall test cannot be performed on the W5A 580 system.						

NOTES

TRANSMISSIONS

W5A 580 Automatic Transmission System (continued)

Transmission Control

The W5A 580 automatic transmission system is fully controlled by the transmission control module (TCM) located in the engine compartment “cool box” along with the engine control module (ECM).

A high speed controller area network (CAN) allows communication between the TCM, ECM, ABS/TC CM, and the instrument pack.

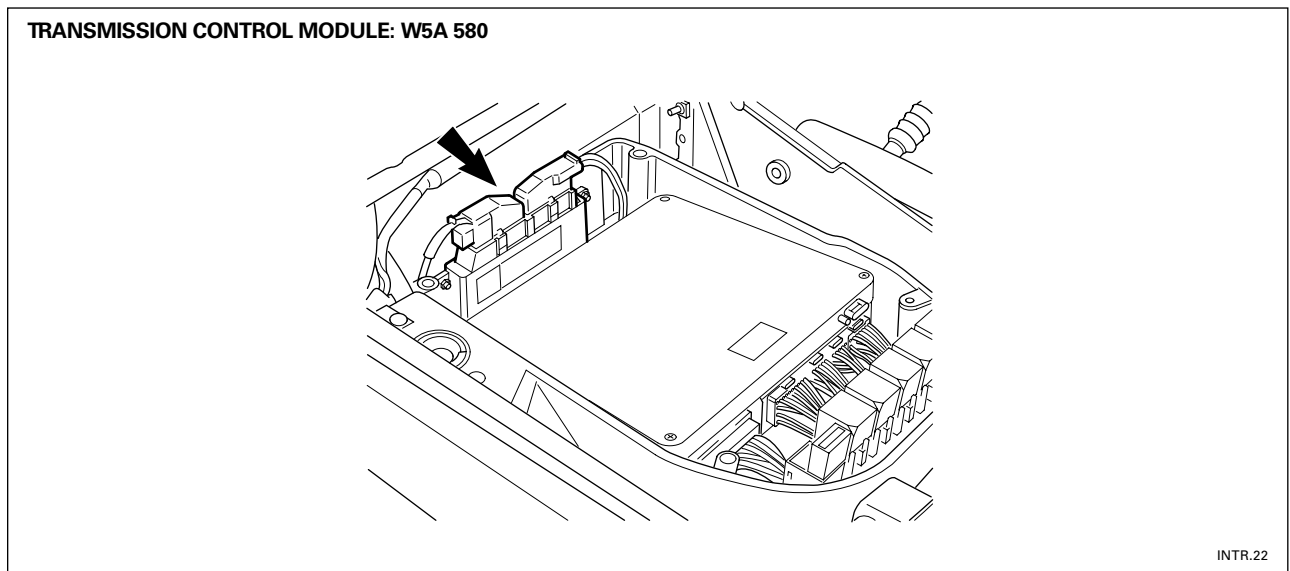

TCM non-volatile memory

TCM adaptive values and DTCs are stored in non-volatile memory (EEPROM). If the vehicle battery is disconnected, all adaptive values and stored DTCs will be retained.

NOTES

INTRODUCTION TO XJ/XK

W5A 580 TCM control incorporates the following control features:

- Normal / Sport operational modes (strategies)
- Shift scheduling / shift feel
- Adaptive pressure control
- Component wear and aging adaptations – shift time, fluid filling time and pressure, TCC control
- Specific driving conditions shift strategies
 - Traction control active
 - Engine / transmission over-temperature (hot mode)
 - Gradient
 - Cruise control
 - Manual shift (M 2, 3, 4)
- Torque converter clutch on, off and controlled slip
- Two Reverse gear ratios
- Shift energy management (engine torque modulation during shift)
- Engine torque reduction during “transmission failure”, Reverse
- On board diagnostics (OBD II and non OBD II)
- Component failure default modes (mechanical and electronic “limp home”)

NOTES

TRANSMISSIONS

Driveshaft

XJ vehicles utilize a two-piece steel driveshaft. Both ends of the driveshaft are fitted with flexible couplings and the two driveshaft sections are connected via a universal joint. The center of the driveshaft is supported in a bearing attached to a bracket installed across the driveshaft tunnel. Driveshaft weight is between 9.9 kg (21.8 lb.) and 10.5 kg (23.1 lb.), depending on model variant.

XK vehicles are equipped with a tubular one-piece aluminum driveshaft. Connection to the transmission output shaft is through a flexible coupling, while a universal joint connects the driveshaft to the final drive. The weight of the driveshaft is 6.93 kg (15.28 lb.).

DRIVESHAFT (XJ SHOWN)

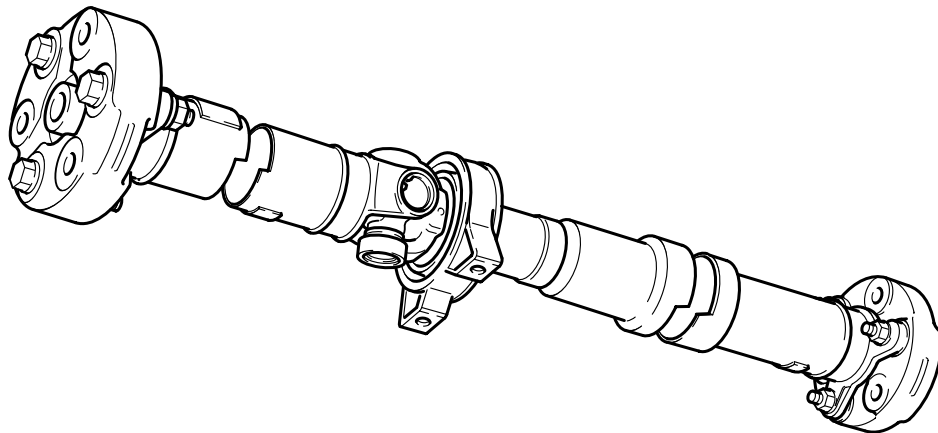

INTR.23

NOTES

Final Drive Unit

The type 14 HU final drive assembly is a hypoid unit with the pinion arranged on the cross-car centerline. The drive-shaft coupling utilizes a cassette-type pinion oil seal, which is an integral part of the pinion flange. This type of seal cannot be separated from the pinion flange and therefore may only be renewed as a complete seal/flange assembly.

The axle shafts are driven by the output flanges which rotate on sealed bearings, these assemblies being retained in the final drive unit by circlips.

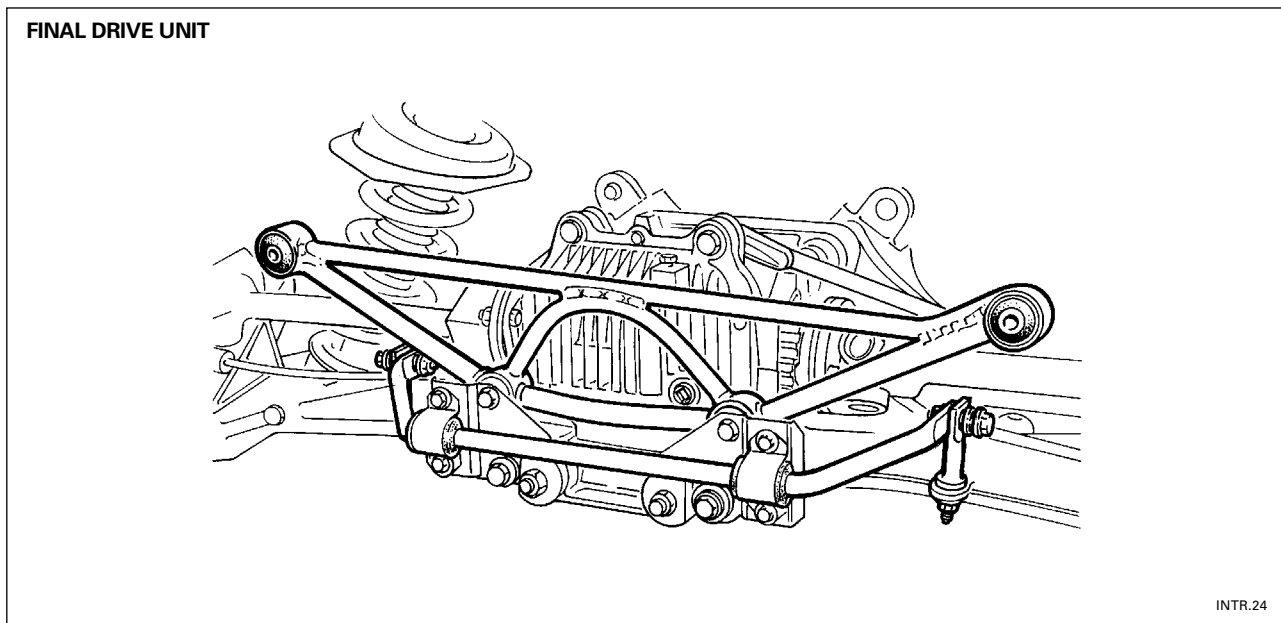

NOTES

INTRODUCTION TO JAGUAR

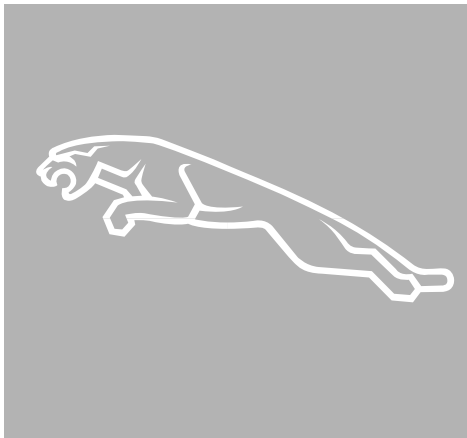

1 INTRODUCTION TO XJ/XK

1.1 Overview

1.2 Engine

1.3 Engine Management

1.4 Transmissions

1.5 Suspension, Steering and Brakes

1.6 Climate Control

1.7 Electrical Distribution System

1.8 Body Systems

1.9 Occupant Protection

1.10 Task Sheets



SUSPENSION, STEERING AND BRAKES

Suspension System

XJ Front Suspension

The XJ V8 Series Sedan front suspension maintains the Jaguar pattern of unequal-length 'A' arms mounted to a sub-frame. The 'A' arm inner fulcrum angles reduce dive during braking. Refinements to the suspension components improve NVH (noise, vibration, and harshness) refinement without compromising ride quality, suspension response, or handling. Caster, camber, and toe are adjustable.

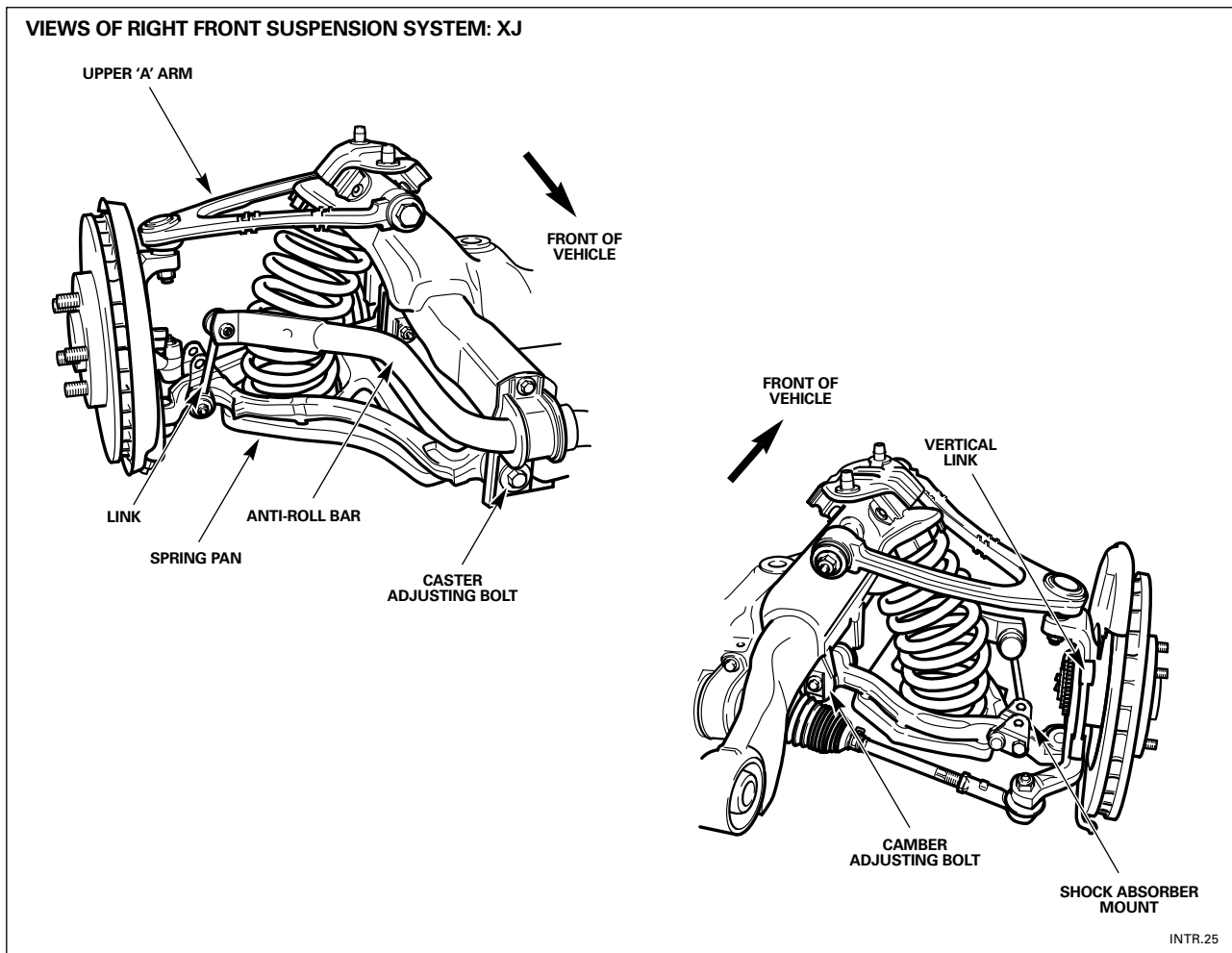

NOTES

SUSPENSION, STEERING AND BRAKES

Suspension System (continued)

XK Front Suspension

Front Crossbeam

The XK8 has a lightweight, cast aluminum, front suspension crossbeam. It is bolted at four points to the body longitudinal members through bonded rubber to metal bushings.

CAUTION: Do not use the aluminum crossbeam as a jacking point. Damage can occur to either the crossbeam, brake pipes or the steering rack.

The steel lower crossbeam beneath the radiator package or the normal car jacking points must be used for front end jacking.

The crossbeam carries the engine mounting points, upper and lower wishbone mounting points, the steel wishbone tie bar, stabilizer bar and the power steering rack.

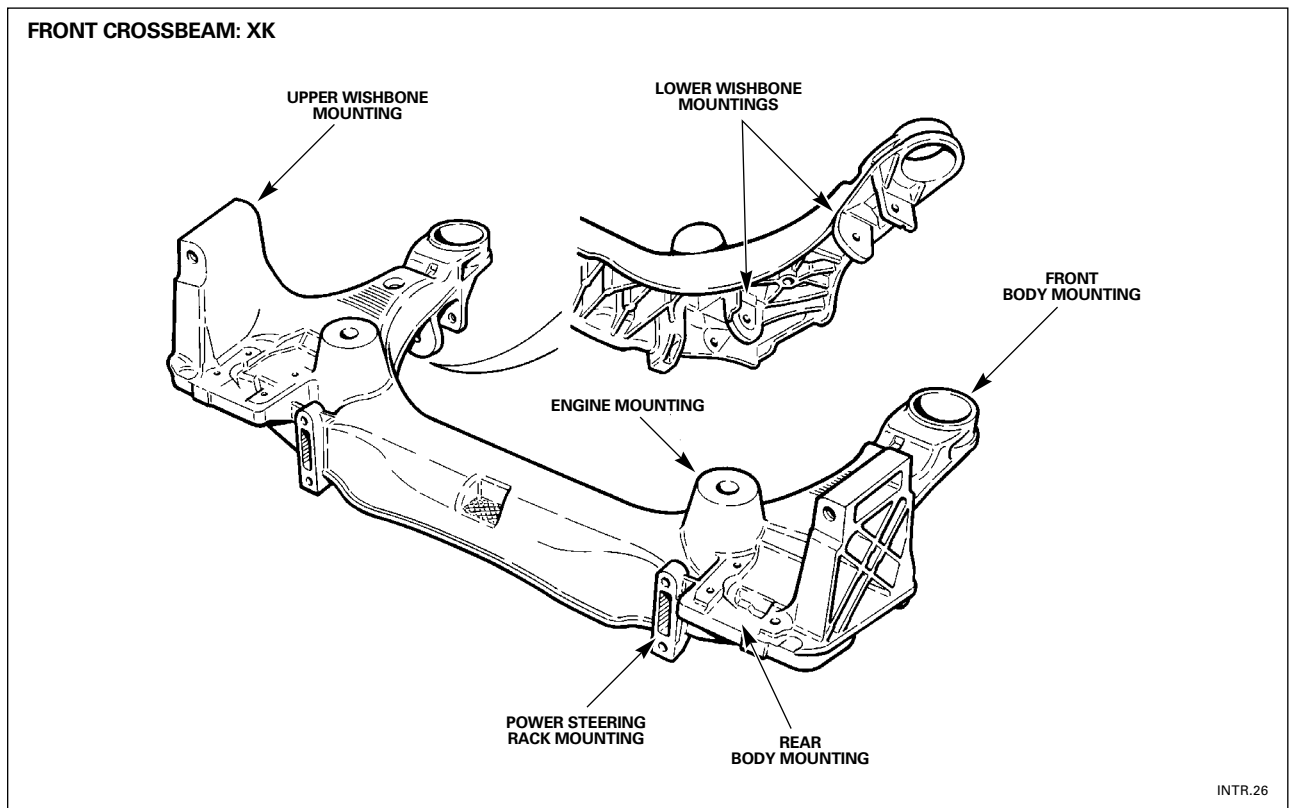

NOTES

FRONT SUSPENSIONS COMPONENTS: XK

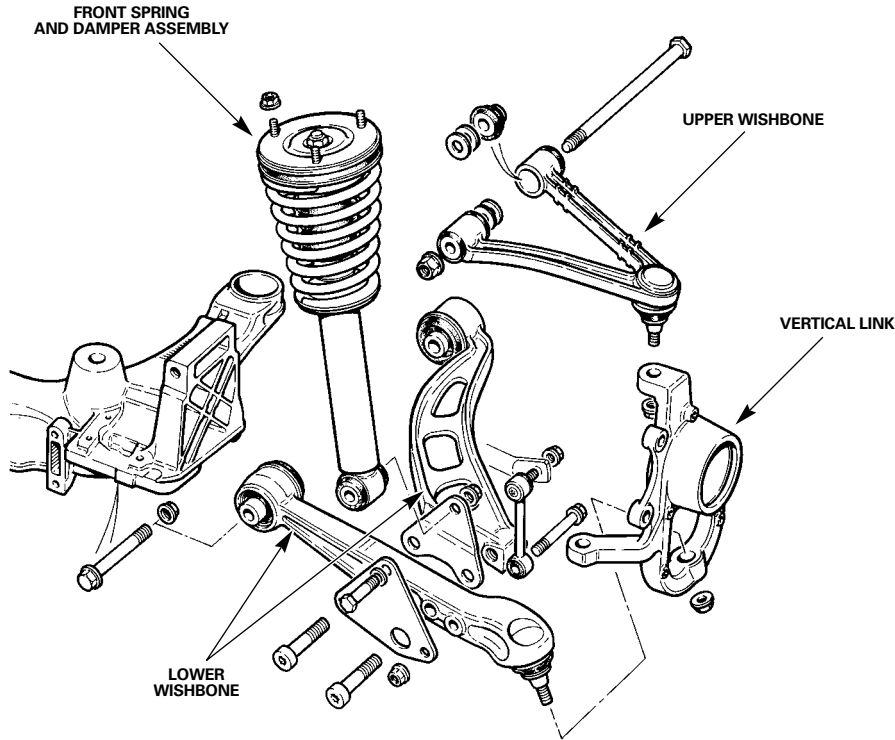

INTR.27

Front Dampers

The top of each front independent suspension co-axial spring and damper assembly is fitted to the car body. The spring is compressed between the top mounting flange and spring pan on the damper body. Damper attachment at the lower end is between two plates located on the rear lower wishbone.

NOTES

FRONT DAMPER: XK

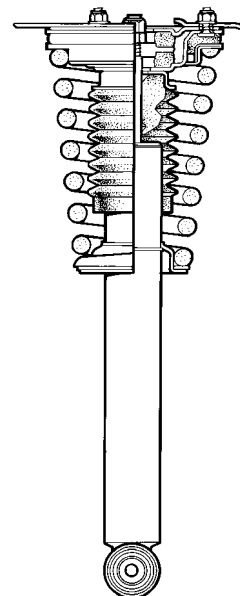

INTR.28

SUSPENSION, STEERING AND BRAKES

Suspension System (continued)

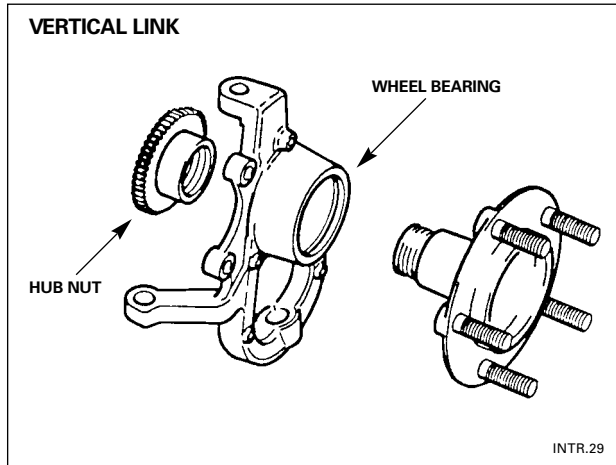

Front Wheel Bearings

The front wheel bearings are sealed units requiring no service or adjustment. The bearing is pressed into the vertical link. The wheel hub is pressed into the bearing and retained by a special hub nut that acts as the wheel speed sensor rotor. The hub nut is locked with a two-pin spring-loaded device. A Jaguar Service Tool is required to remove the bearing hub.

NOTES

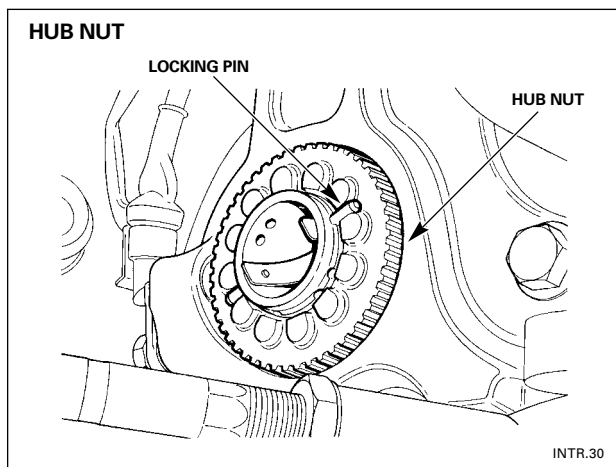

Rear Suspension

The independent rear suspension incorporates co-axial spring and shock absorber units, a subframe, wishbone tie, pendulum assembly, mounting bracket, differential strut, cast wishbones and hub carriers. The suspension assembly is positively located by the subframe, mounting bracket and monostrut. The outer extremity of each wishbone is secured to its respective hub carrier assembly by a fulcrum bolt. Each fulcrum bolt head incorporates an eccentric circular flange, which locates in a groove in the front face of the wishbone arm. Rotation of the fulcrum bolt results in horizontal movement of the bolt shank in an elongated hole in the rear of the wishbone arm. This action achieves corresponding movement of the hub carrier, facilitating adjustment of road wheel toe. A rear stabilizer bar is installed on supercharged models.

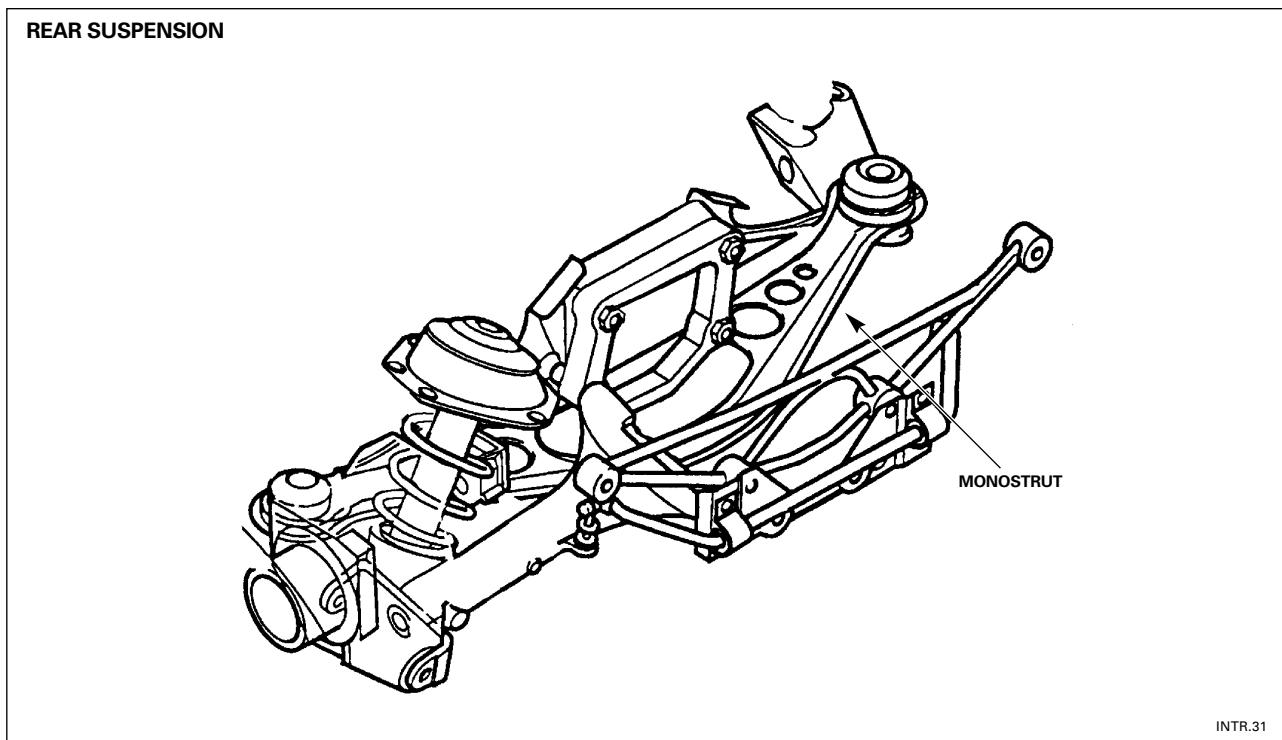

NOTES

SUSPENSION, STEERING AND BRAKES

Suspension System (continued)

Adaptive Damping System

The optional adaptive damping system is automatic requiring no input from the driver. The system selects the best damper characteristics to suit the driving conditions and improve the ride and the vehicle handling qualities.

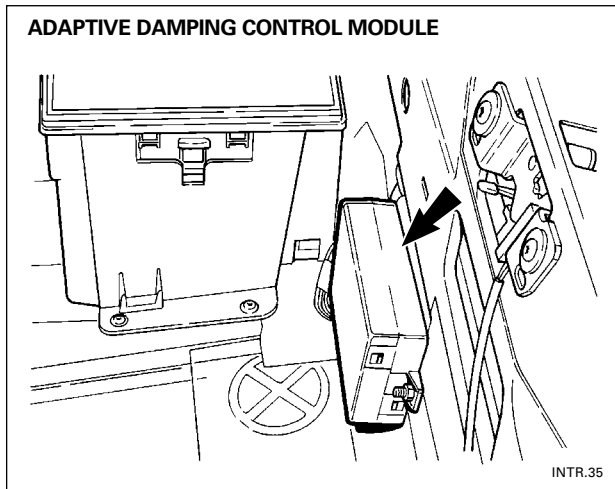

System Components

An ADCM is located in the spare wheel well adjacent to the battery box.

Three accelerometers, (movement sensors) are used to provide ride signals to the ADCM. There are two vertical movement sensors – one located on the bulkhead below the air conditioning unit casing and the other located in the trunk below the fuel tank. The rear vertical sensor in the convertible is located below the fuel tank, behind the tank retaining plate. A single horizontal movement sensor is mounted within the forward bulkhead extension compartment which contains the ECM and TCM.

Four adaptive dampers are fitted in place of the normal dampers and are easily identifiable by the cable exiting the top of the damper.

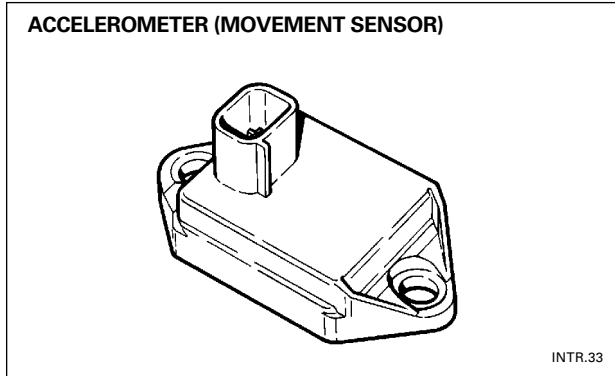

NOTES

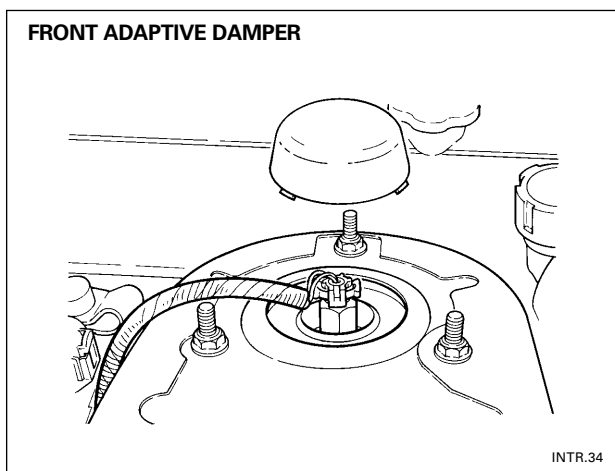

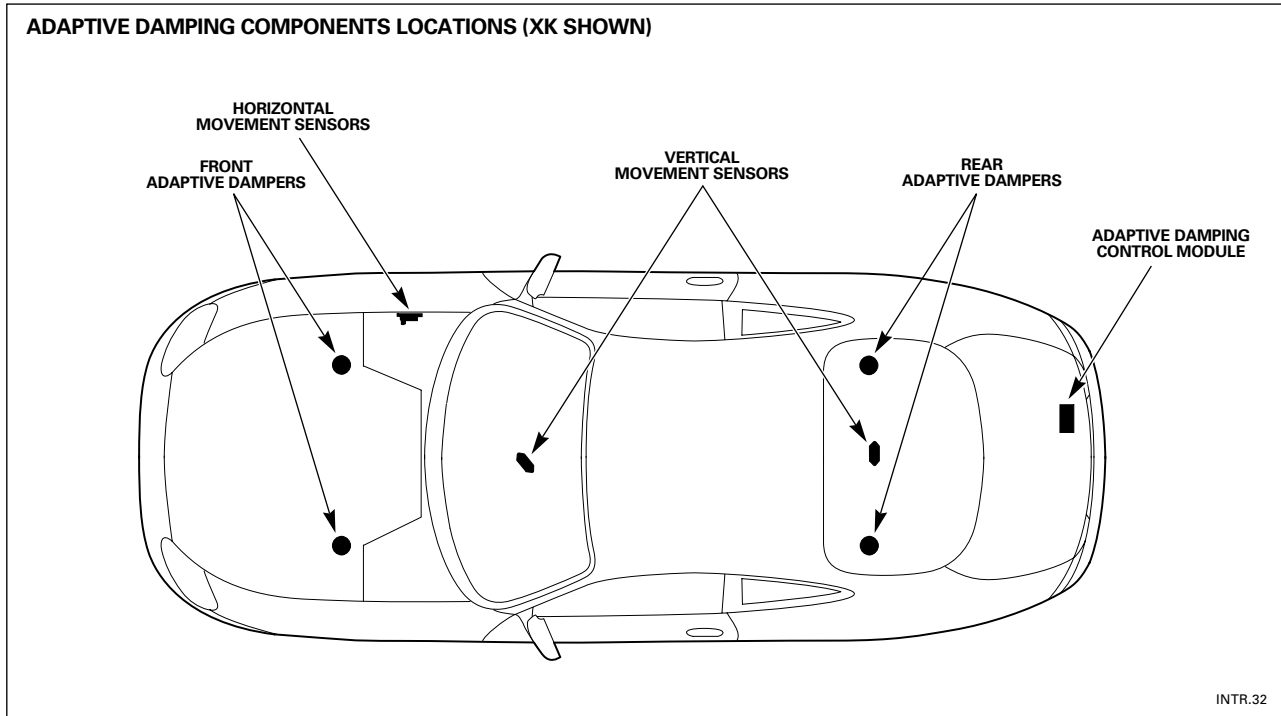

System Operation

Two damper settings are available, soft and firm, and all four dampers operate simultaneously. While the vehicle is standing still the dampers will be in the firm setting. They will switch to the soft setting when the vehicle speed exceeds 8 km/h (5 mph). When the vehicle encounters a bump in the road, the bump will be detected by the accelerometers and the ADCM will then switch the dampers to the firm setting to damp out the resulting body motion. When cornering is sensed by the lateral accelerometer, the ADCM will switch the dampers to firm to reduce the roll rate and improve wheel control. When the brake switch is activated the ADCM receives a signal and the dampers will be switched to firm to reduce the pitch rate and improve wheel control.

After the event has passed the dampers will revert to the soft setting. If a system failure occurs a text warning, ‘Suspension Fault’, will be shown on the dashboard message center and the amber warning light will illuminate. The vehicle is still safe to drive. The system always fails to the firm setting.

For fault diagnosis, interrogation of the ADCM can be made using WDS.

NOTES

SUSPENSION, STEERING AND BRAKES

Power Assisted Steering (PAS) System

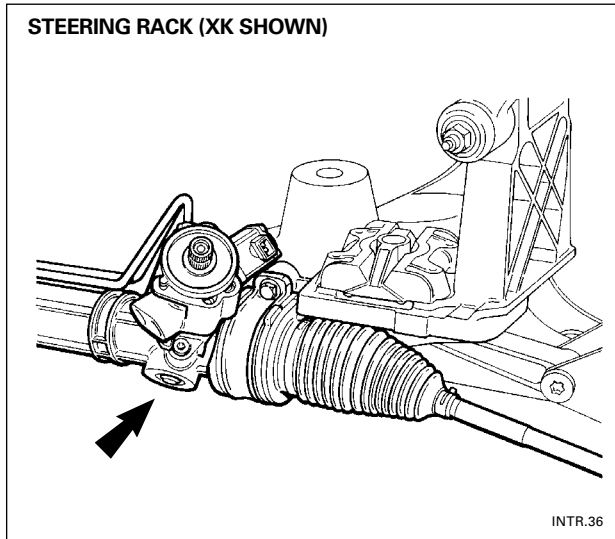

Steering Rack

The steering rack is a ZF Servotronic speed sensitive, variable ratio, rack and pinion, power assisted unit and is standard on all models. Service is limited to the transfer pipes, bellows, outer ball joint assemblies, transducer, centralizing cap and their clips and fittings. The track rod assembly, including the inner ball joint, is not a serviceable item. Centralization of the rack is made by a locating pin and the unit cover. The rack is mounted across the rear of the front suspension aluminum crossbeam by wrap-around 'U'-brackets and bushings. The handed and orientated bushings and "U"-brackets are replaceable without removal of the rack. Incorporated in the rack is an integrated power cylinder, a rotary hydraulic valve and positive center feel torsion bar. The rotary control valve distributes and controls the degree of hydraulic pressure needed to support any given driving situation. This arrangement gives the driver a power assist which is speed sensitive allowing ease of parking combined with high speed feel.

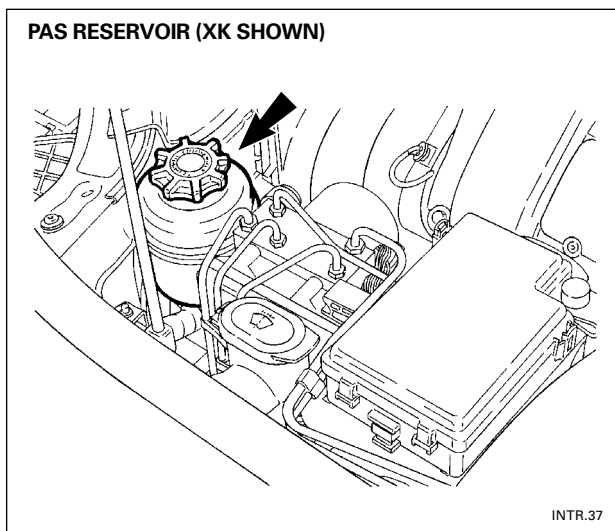

PAS Pump

The power assist pump is a new Hobourn Automotive Series 500, belt driven by the engine and contains no serviceable parts.

PAS Reservoir

The 0.4 litre (0.42 US quart) fluid capacity oil reservoir is rubber mounted in the engine compartment to the rear of the left-hand headlamp. It has a screw cap with integral dipstick and incorporates a 10 micron paper filter. The filter is not a serviceable item. If any major PAS component is replaced then the reservoir and fluid must also be changed.

PAS Control Module

The PASCAM, mounted in the LH lower 'A' post (XJ) or in the right-hand side fascia (XK), receives a speed signal from the instrument cluster and sends a variable current signal to the PAS rotary valve to provide speed feel control to the driver.

NOTES

Anti-Lock Braking (ABS) Systems

ABS controls the hydraulic pressure to the front and rear wheel brake calipers to help prevent the wheels from locking and skidding during braking.

Stability Control (ASC)

ASC is a feature of XK ABS that reduces engine torque to prevent acceleration wheel slippage throughout the total vehicle speed range.

Traction Control (TC)

TC is added to anti-lock braking systems to control wheel spin when starting off and at lower speed acceleration. TC reduces engine torque and applies braking to the slipping drive wheel(s). During TC operation, the ABS / TC control module also cancels cruise control and inhibits transmission downshifting. Upshifts are also inhibited below a specified speed.

Dynamic Stability Control (DSC)

DSC is an enhanced anti-lock brake system which is designed to improve dynamic stability when braking. The system uses the existing sensors and braking hardware but the brake control modulator software is modified to provide a more detailed analysis of the input sensor data. This allows the system to recognize any differences in speed between the four wheels due to slip angle and load changes, caused by critical situations on bends, varying road surfaces or abrupt steering movements. Under these conditions, the system reduces or increases braking on individual wheels to provide compensating yaw movements which stabilize the course of the vehicle. Note that the Dynamic Stability Control system is only active when the brakes are applied (unlike traction control).

The modified brake control modulator is physically unchanged from the previous unit except that the valve block is keyed to the ABS/TC control module to ensure that only Dynamic Stability Control components are assembled together.

XK ABS Summary

Model Year	ABS System	Power Assist System	MIL	On-Board Diagnostics	
				DTCs	Diagnostic Connector
1997 – 1999	Teves Mk 20-l: ASC standard, TC optional	Vacuum, Dual Diaphragm	Yes	Yes, C Codes (WDS)	DLC – driver side ‘A’ post below fuse box
2000 – 2002	Teves Mk 20-l: ASC/TC standard, DSC optional	Vacuum, Dual Diaphragm	Yes	Yes, C Codes (WDS)	DLC – driver side ‘A’ post below fuse box

NOTES

SUSPENSION, STEERING AND BRAKES

Anti-Lock Braking (ABS) Systems (continued)

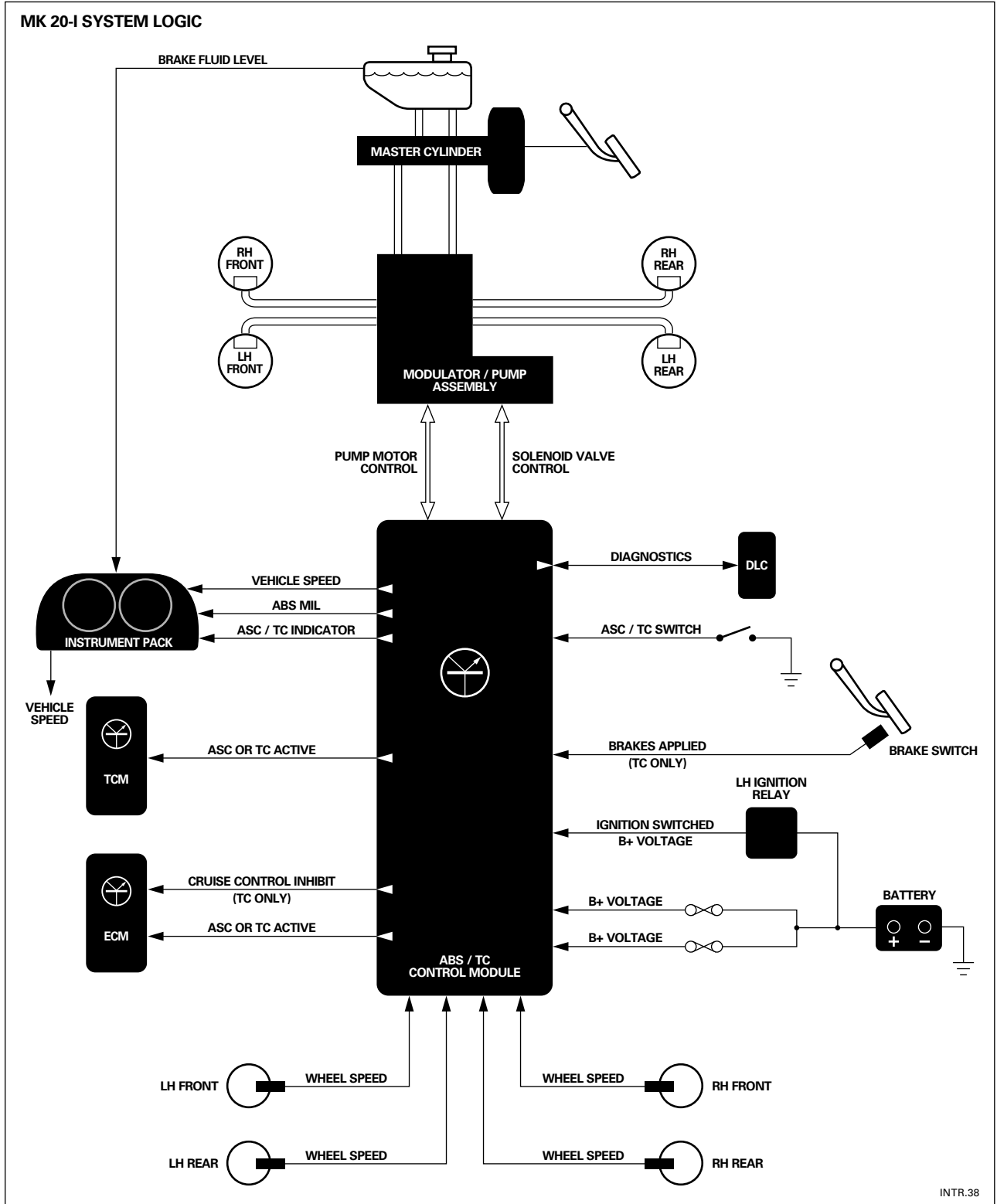

INTR.38

INTRODUCTION TO JAGUAR

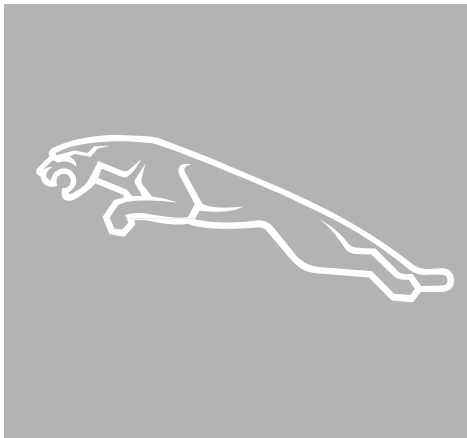

1 INTRODUCTION TO XJ/XK

- 1.1 Overview
- 1.2 Engine
- 1.3 Engine Management
- 1.4 Transmissions
- 1.5 Suspension, Steering and Brakes
- 1.6 Climate Control**
- 1.7 Electrical Distribution System
- 1.8 Body Systems
- 1.9 Occupant Protection
- 1.10 Task Sheets

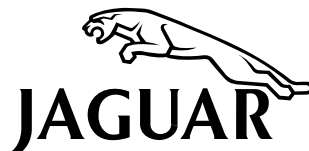

CLIMATE CONTROL

Overview

The Jaguar Denso Climate Control System, introduced in the 1995 Model Year XJ, is standard equipment on XJ and XK models. The system is controlled through a microprocessor-based electronic control module and a microprocessor-based control panel. The system produces the driver selected comfort level by controlling air flow volume and distribution using cooling from the air conditioning system and heat from the engine cooling system. To control cabin temperature, the system uses a heater valve to regulate the heater matrix temperature. The Denso system differs from previous Jaguar systems that controlled cabin temperature with flaps in the air conditioning heater unit to blend cooled air with the heated air from an unregulated heater matrix. The windshield, rear window, and mirror heater circuits are integral with the Denso climate control system.

AIR DISTRIBUTION (XJ SHOWN)

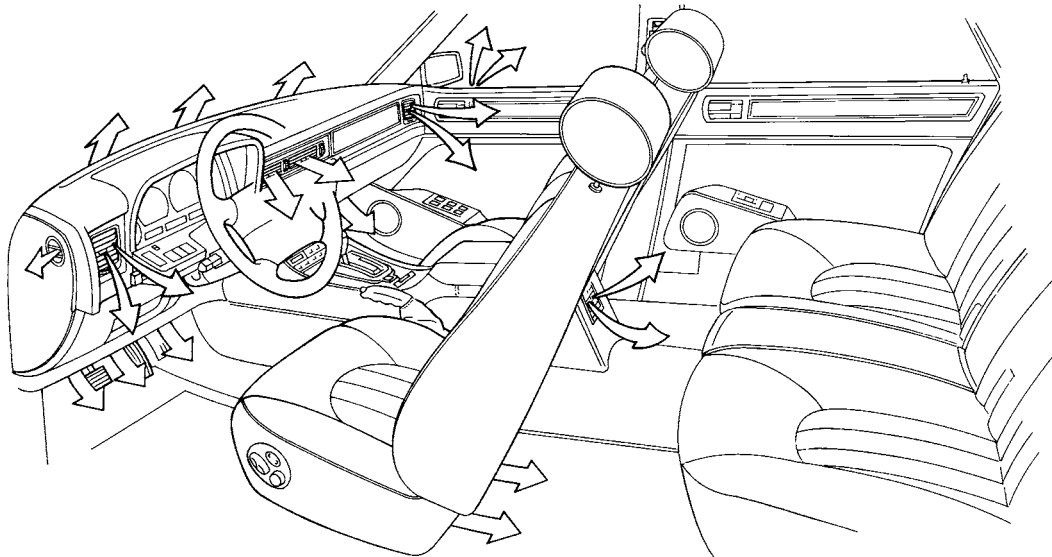

INTR.39

NOTES

Climate Control Panel

The control panel is the interface between the driver and the air conditioning control module (A/CCM). It has a 4-bit microprocessor that processes information and converts the selected switch positions and settings into digital data that is communicated to the A/CCM over a serial data link.

Climate Control System ON / OFF

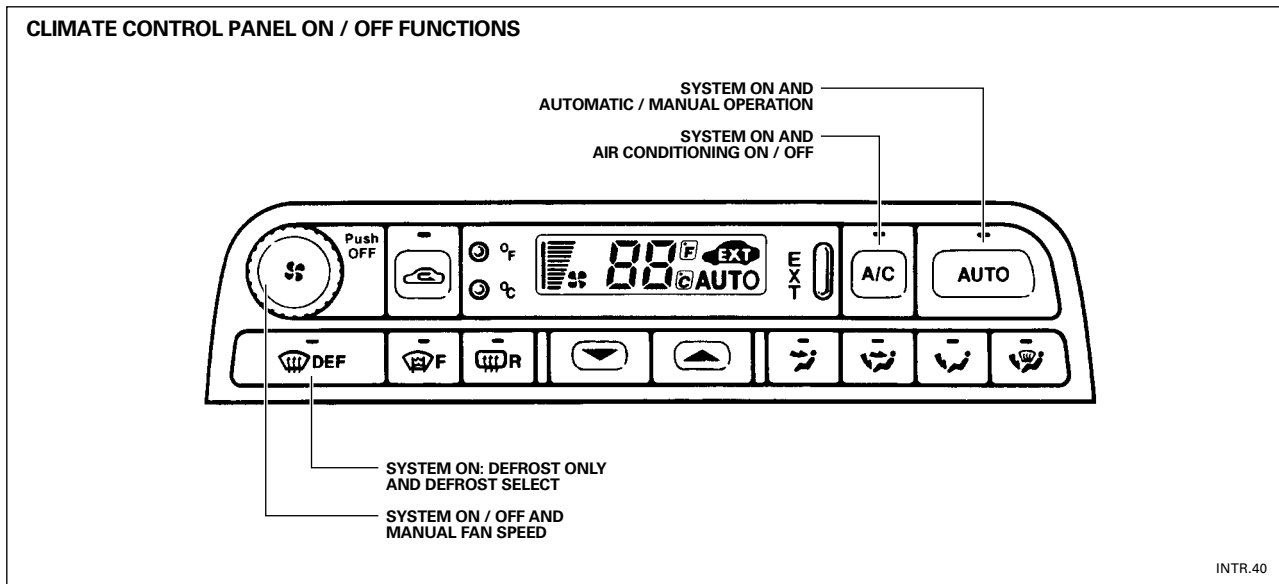

The climate control panel is switched ON by pressing one of the following panel controls:

- AUTO** AUTO switches the system ON in the automatic mode; AUTO appears on the panel display. Temperature, blower speed and air distribution are automatically controlled. If heat is required, the blowers will not operate until the engine temperature has risen above 30 °C (87 °F), unless defrost is selected. The blowers operate any time cooling is required. Except in recirculation mode, blower speed is linked to vehicle speed to adjust for the ram air effect at higher vehicle speeds.
- A/C** A/C switches the system ON in air conditioning mode only. The system uses the air conditioning settings in effect the last time air conditioning was used.
- DEF** DEF switches the system ON in the defrost mode only. Air is directed to the windshield only. The blowers operate at maximum speed. Temperature is automatically controlled by the A/CCM.
- Push OFF** Push OFF switches the system ON in the AUTO mode. AUTO appears on the panel display.

The climate control system is switched OFF as follows:

- Push OFF** Push OFF is the only method for switching the system OFF. When push OFF is pressed, the system is switched off and the fresh air or recirculation blower flaps are set to recirculation, shutting off outside air intake.

NOTES

CLIMATE CONTROL

Climate Control Panel (continued)

Climate Control Panel Switch Functions

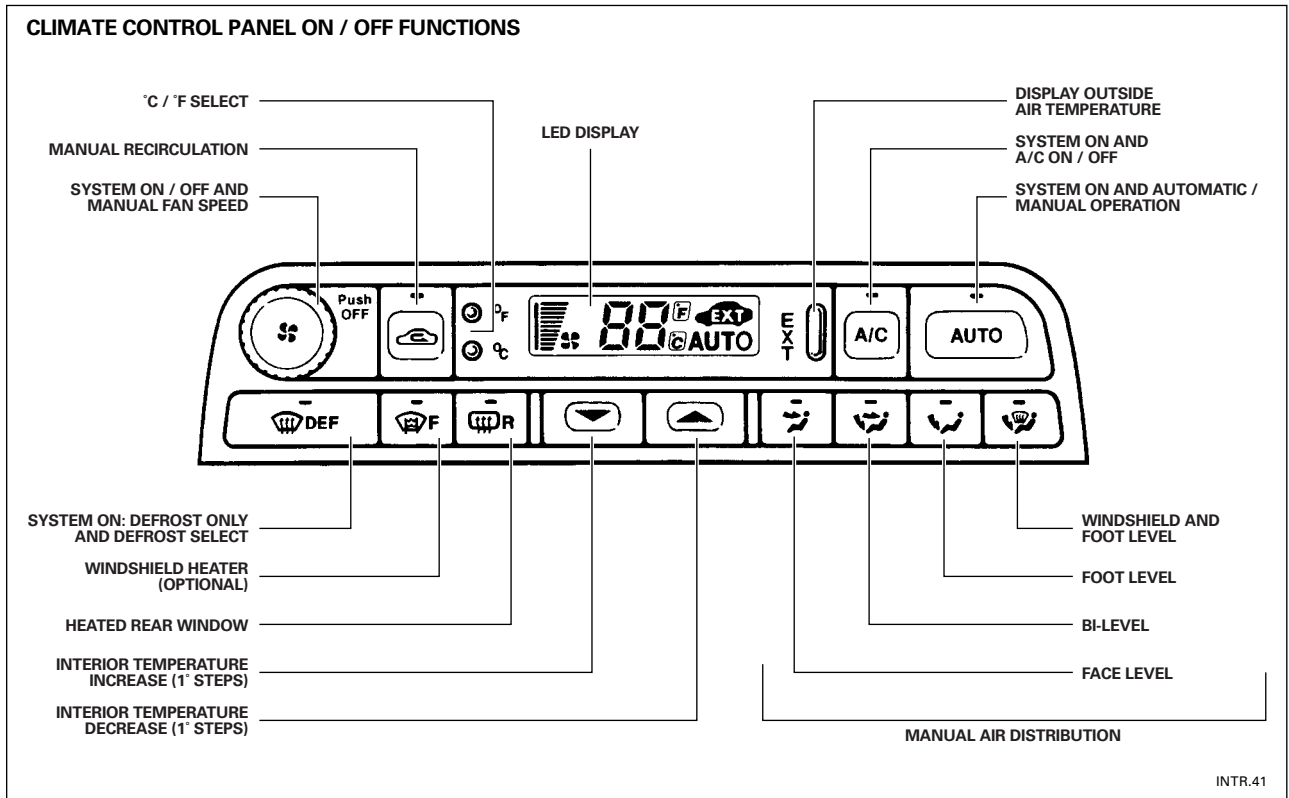

Push OFF

This switch is a combination switch for manual blower speed control and system ON / OFF. Pushing the rotary switch provides system ON or OFF. Turning the switch provides manual blower control and overrides the AUTO control blower speed functions.

Recirculation

Pressing this switch closes off the outside air intake and recirculates cabin air. The LED indicates the status.

Momentary press (one beep) – five minute operation

Long duration press (two beeps) – continuous operation

A/C

This switch signals the A/CCM to request air conditioning compressor operation from the engine control module. The LED indicates when compressor operation is requested.

AUTO

When AUTO is selected (LED on), control of air distribution, blower speed, and interior temperature is fully automatic. Manual overrides, such as pressing one of the air distribution buttons, turning the blower speed control, or selecting A/C, will disengage the automatic function. The AUTO LED will go out to indicate that a manual override has been selected. When AUTO is pressed again, manual overrides are canceled and full automatic system control is restored.

NOTES

- DEF** This switch selects defrost. Maximum blower speed occurs and all air is directed to the windshield. Blower speed can be reduced by turning the blower speed control rotary switch. Temperature is controlled by the A/CCM; however, the temperature can be adjusted by using the temperature select UP / DOWN switches. The optional heated windshield will also be switched on for six minutes. If DEF is switched off or the system is switched off before the six minutes has elapsed, the heated windshield will remain on for the six minute timed period. The LED indicates the status.
- Heated windshield** This switch selects the optional windshield electric heater. The heater will operate for six minutes, then time-out. The LED indicates the status. The windshield heater operates only when the engine is running.
- Heated backlight** This switch selects the backlight and door mirror heaters. The backlight will operate for 20 minutes and the door mirror heaters will operate for 11 minutes, then time-out. The LED indicates the status. The heated backlight and mirror heaters operate only when the engine is running.
- Interior temperature** The temperature select buttons increase or decrease the desired interior temperature in 1° increments, °C or °F, as selected.
- Manual air** Four air distribution manual override buttons are used to override the automatic function and distribution override distribute air as the driver selects: FACE, FACE AND FEET (bi-level), FEET ONLY and WINDSHIELD AND FEET. The LED indicates the status.

NOTES

CLIMATE CONTROL

Refrigeration System

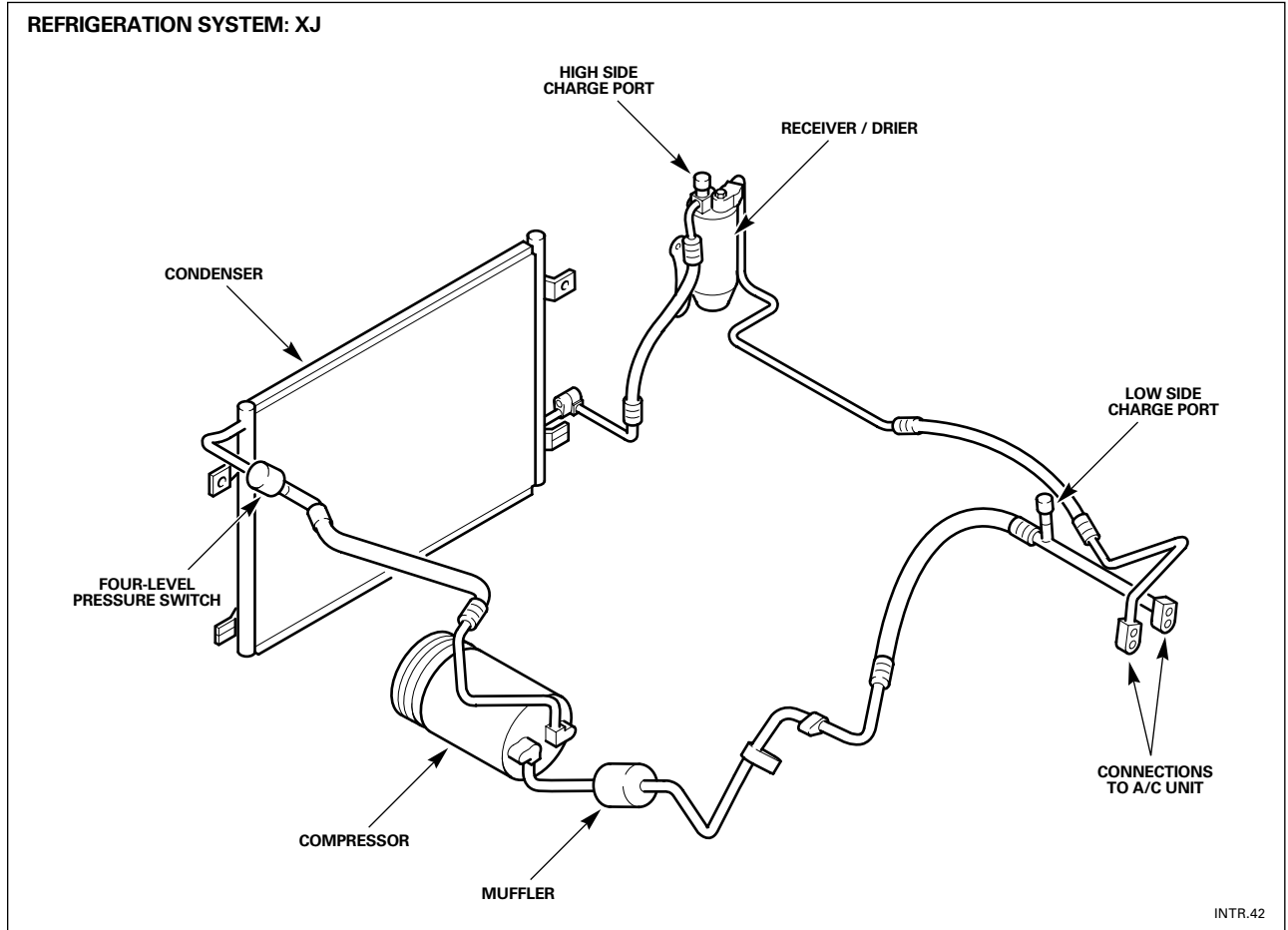

NOTES

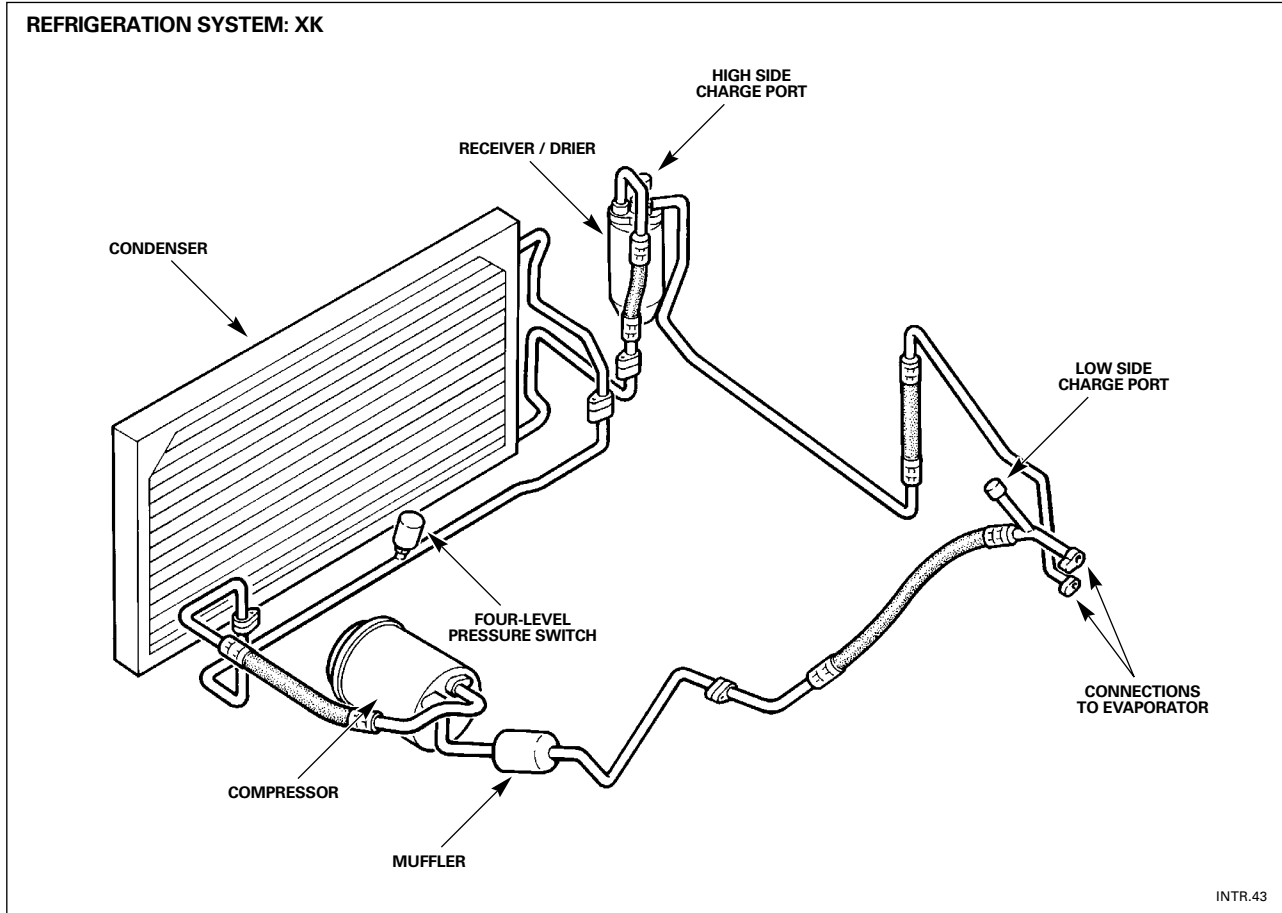

NOTES

CLIMATE CONTROL

System Diagnostics

The A/CCM continuously monitors the climate control system for faults. If a fault is detected the A/CCM flags a DTC corresponding to the fault. All DTCs can be retrieved using WDS. In addition, some fault codes can be displayed on the control panel screen. The WDS DTCs consist of 5 characters; the codes displayed on the control panel are 2-digit numbers. WDS and panel display fault code information is supplied with the description of the applicable components in the DTC Summary.

System Self-Test

Some system generated fault codes can be displayed on the control panel screen. When a fault is flagged, an audible “beep” will sound and the message “Er” will be displayed for five seconds, after the ignition is switched to position II. To display stored “panel fault codes”, follow this procedure:

- **Switch off the ignition**
 Press and hold the AUTO and FRESH / RECIRC buttons simultaneously while switching the ignition to position II. All of the panel LEDs and all LCD segments will flash ON and OFF. Any function LED indicator or LCD segment that does not flash suggests a fault condition within that area of the panel, or with the LED or LCD.
- **Press AUTO**
 The control panel display will flash and scroll through the list of flagged fault codes. A maximum of five codes will be stored and displayed. If 0 is displayed, no fault codes are flagged.
- **Press FACE to manually scroll through the fault codes**
 When a fault code is displayed, an accompanying beep will indicate if the fault is present. If the code is not accompanied by a beep, the fault occurred previously.
NOTE: Faults that are present can not be cleared until the cause of the fault is repaired.
 To clear fault codes, press HRW and FACE simultaneously. Wait 30 seconds for the A/CCM to retest the system and reflag any current faults.
- **Press PUSH OFF to return the system to normal operation (default panel settings)**

Panel Communication Check

The data link, power, and lighting circuits between the A/CCM and the control panel can be checked by simultaneously holding AUTO and FAN while the ignition is switched to position II. Panel control LEDs will illuminate to indicate that each circuit is OK, as follows:

Circuit	LED
Ignition switched power supply (pos. II) circuit	Defrost button LED
Ignition switched power supply (pos. I, Aux.) circuit	Face button LED
Clock circuit	Bi-level button LED
Start circuit	Foot button LED
Data circuits	Defrost / foot button LED
Panel lighting	Recirc. button LED (Headlights ON!)

Actuator Check

The control panel, system actuators and certain components can be checked by simultaneously holding AUTO and FRESH / RECIRC while the vehicle is being started.

Control Panel

All of the panel control LEDs and LCD segments will flash on and off to indicate that each panel circuit is OK. If an LED does not flash, a fault condition in that area of the panel is indicated, or the LED has failed. If an LCD segment does not flash, a fault condition in that area of the panel is indicated, or the LCD segment has failed.

Actuators and Components

Check the actuators by selecting AUTO, then FRESH / RECIRC. Select FACE to cycle through the actuator mode conditions 20 – 27 as shown in the following table. After the check is complete, select PUSH OFF to restore normal system operation.

Actuator Check Chart

Code	Blower level	Face	Outlet: Foot	Defrost	Cool Air bypass	Fresh / recirc	Compressor	Heater valve	Heater pump
20	0	open	closed	closed	closed	fresh	OFF	closed	OFF
21	1	open	closed	closed	closed	fresh	OFF	closed	ON
22	10	open	closed	closed	open	1/2 open	A/C ON	closed	ON
23	17	bleed	1/2 open	closed	1/2 open	1/2 open	A/C ON	6 sec. pulse*	ON
24	17	bleed	1/2 open	closed	closed	recirc	A/C ON	6 sec. pulse*	ON
25	23	closed	open	bleed	closed	recirc	A/C ON	open	ON
26	23	closed	1/2 open	1/2 open	closed	recirc	A/C ON	open	ON
27	31	closed	closed	open	closed	open	A/C ON	open	ON

* The heater valve operates on a 6 second pulse (3 seconds ON, 3 seconds OFF)

NOTES

INTRODUCTION TO JAGUAR

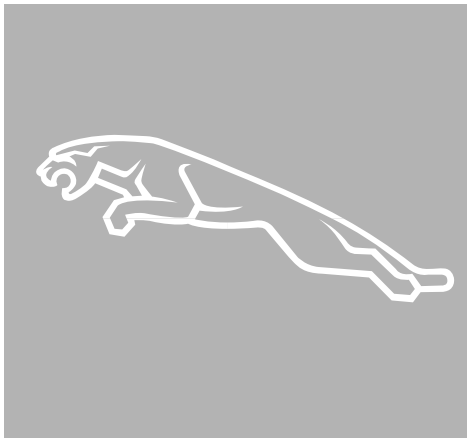

1 INTRODUCTION TO XJ/XK

- 1.1 Overview
- 1.2 Engine
- 1.3 Engine Management
- 1.4 Transmissions
- 1.5 Suspension, Steering and Brakes
- 1.6 Climate Control
- 1.7 Electrical Distribution System**
- 1.8 Body Systems
- 1.9 Occupant Protection
- 1.10 Task Sheets



ELECTRICAL DISTRIBUTION SYSTEM

Electrical System Architecture

The XJ / XK vehicle electrical system is a ground side switched system. The ignition switch switches ground circuits on / off to complete system circuits and apply power. Circuits that require ignition switch position control are supplied with “ignition switched grounds”. Both power grounds (high current consumers) and logic grounds (electronic switching circuits) are used throughout the system.

Power Distribution

Distribution cables supply battery power through a high power protection module to the starter motor and to five fuse boxes. Harnesses distribute battery, auxiliary and ignition power from the fuse boxes to all the user components.

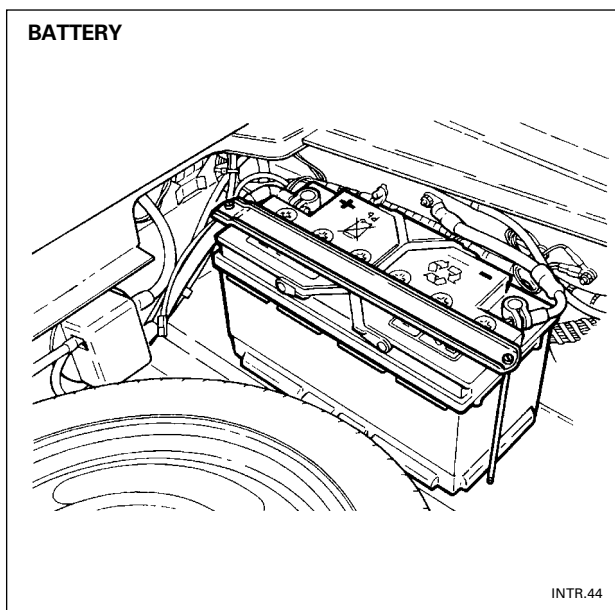

Battery

The DIN88, 92 ampere hour battery is installed on the right side of the trunk floor below the trim.

CAUTION: Sulfuric acid is highly corrosive. Batteries produce explosive gasses. Keep flames and sparks away. Always wear protective clothing, face, and eye protection to prevent injury while working around batteries.

CAUTION: Open both doors, or lower the glass of both doors, before disconnecting the battery. Disconnecting the battery disables the automatic glass drop/raise function. Opening a door when the automatic glass drop/raise function is disabled and the door glass are closed could damage the door seals.

NOTES

High Power Protection Module: 1997 – 2000 MY

The high power protection module contains three 250 amperes fuses. Two fuses connected in parallel provide 500 amperes protection for the starter supply. The third fuse provides 250 amperes protection for the fuse box supplies.

High Power Protection Module: 2001 – 2002 MY

A new high-power protection module has been fitted which incorporates two individual power cable covers. The connectors on the power cables have been modified to accommodate the new protection module.

NOTES

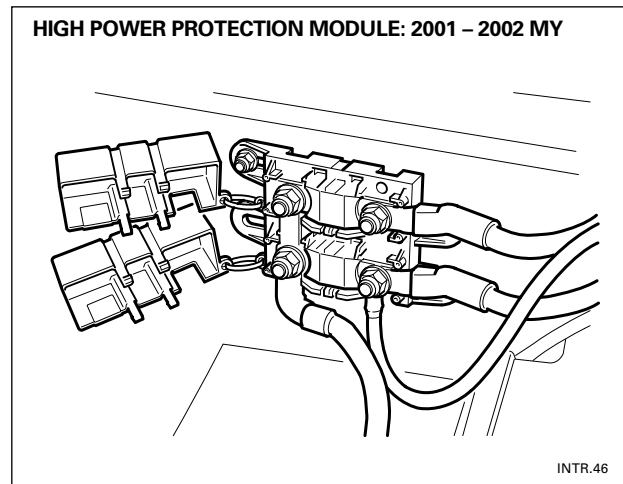
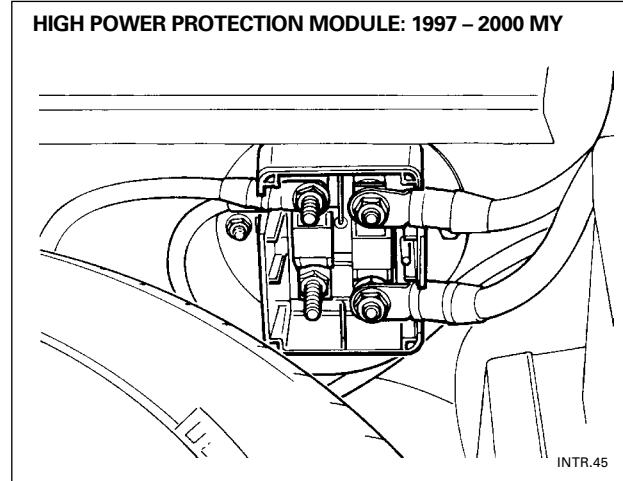

ELECTRICAL DISTRIBUTION SYSTEM

Power Distribution (continued)

XJ Fuse Boxes

Five fuse boxes contain the protection fuses for all the electrical circuits. The engine compartment fuse box and the engine management fuse box are located on the left side of the engine compartment. The heelboard fuse boxes are located behind the left and right heelboards. The trunk fuse box is installed in the electrical carrier in the trunk.

CAUTION: Always replace blown fuses with the same rated fuse.

NOTES

FUSE BOX AND RELAY LOCATIONS: XJ

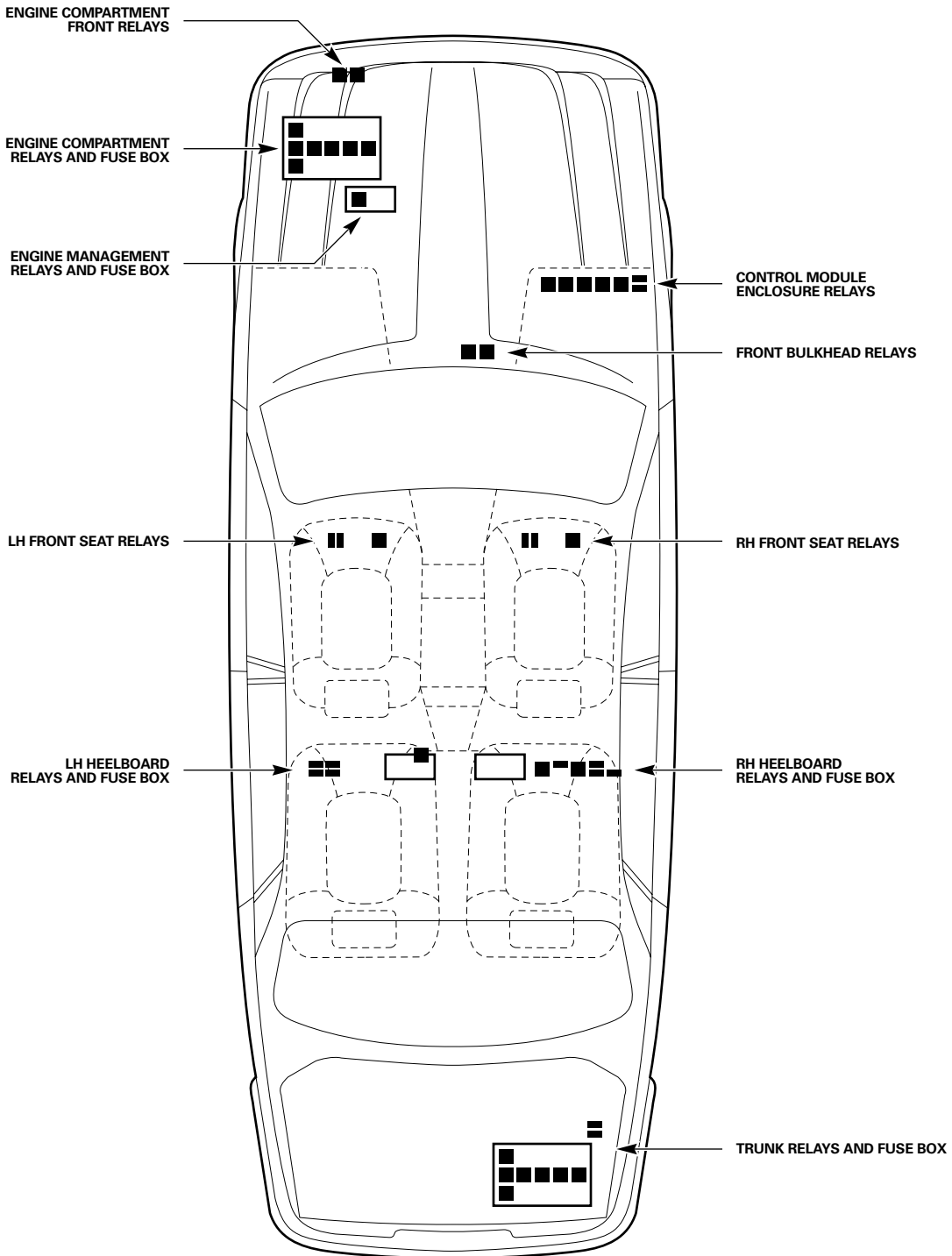

INTR.48

ELECTRICAL DISTRIBUTION SYSTEM

Power Distribution (continued)

XK Fuse Boxes

Five fuse boxes contain the protection fuses for all the electrical circuits. The engine compartment fuse box is located on the left side of the engine compartment; the control module enclosure fuse box is located in the right hand control module enclosure. The driver and passenger fuse boxes are located on the left and right fascia, respectively. The trunk fuse box is installed in the electrical carrier in the trunk; spare fuses and a fuse extractor tool are installed on the underside of the lid.

CAUTION: Always replace blown fuses with the same rated fuse.

NOTES

FUSE BOX AND RELAY LOCATIONS: XK

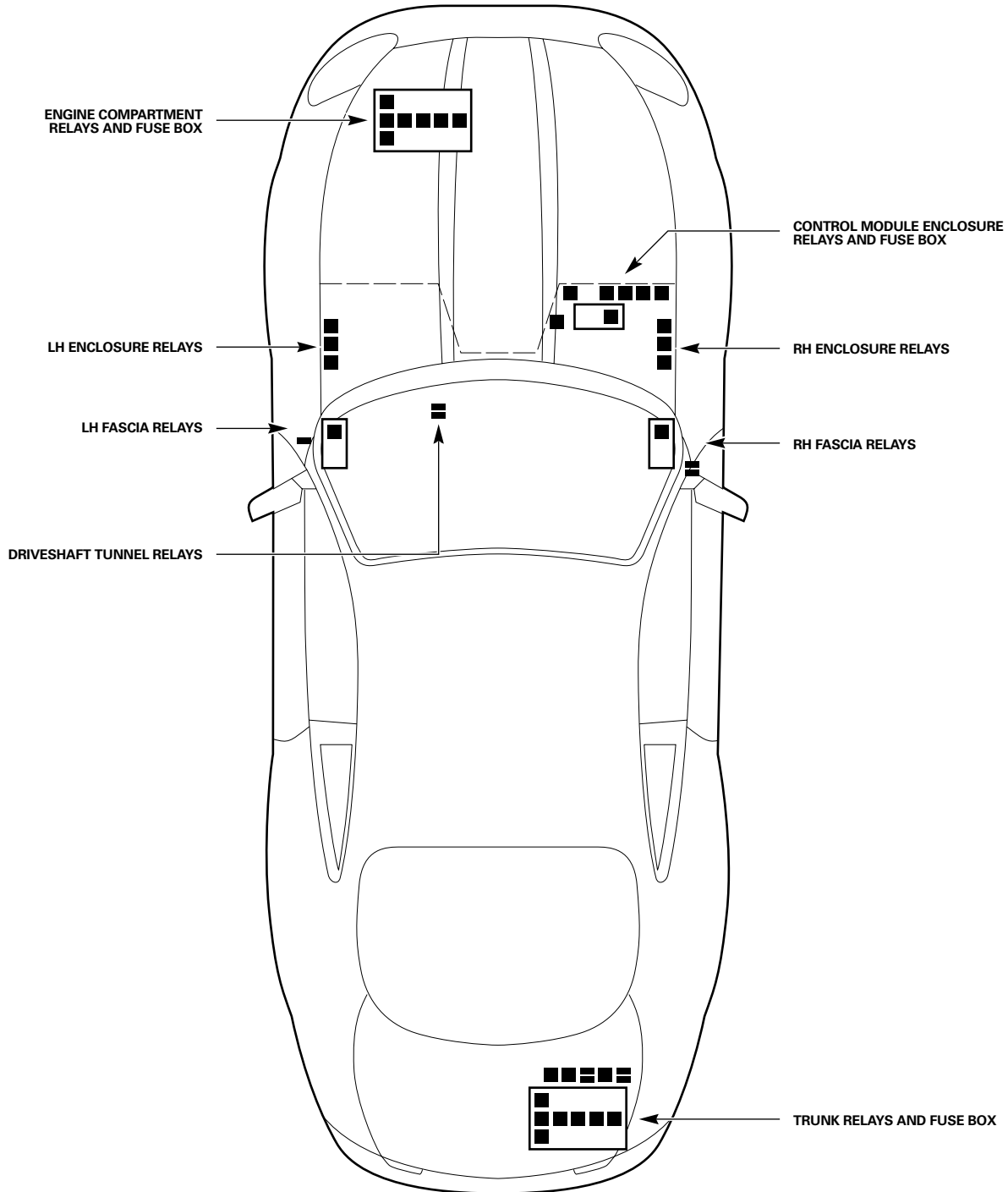

INTR.47

ELECTRICAL DISTRIBUTION SYSTEM

Control Modules

XJ Control Module Locations

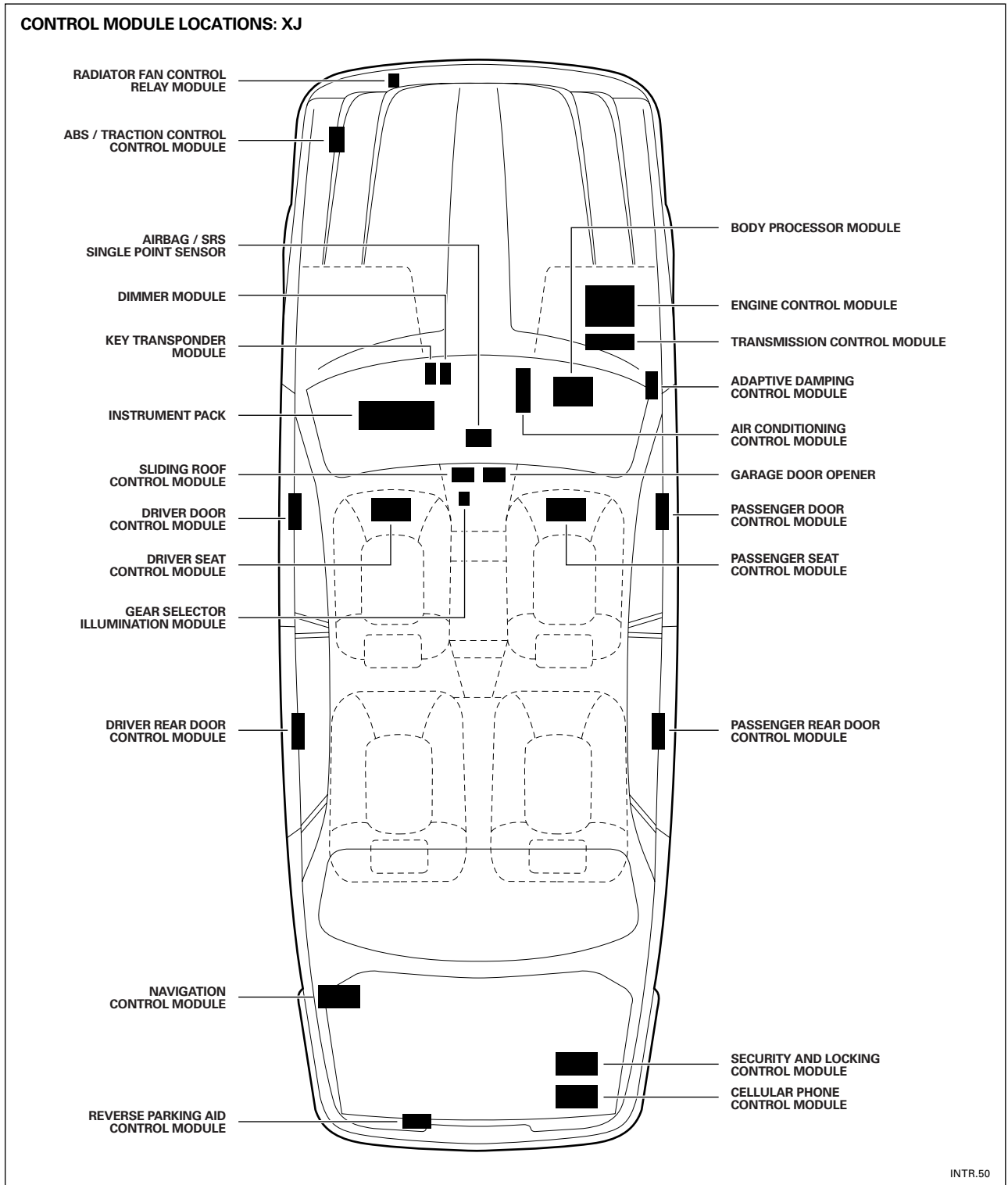

XK Control Module Locations

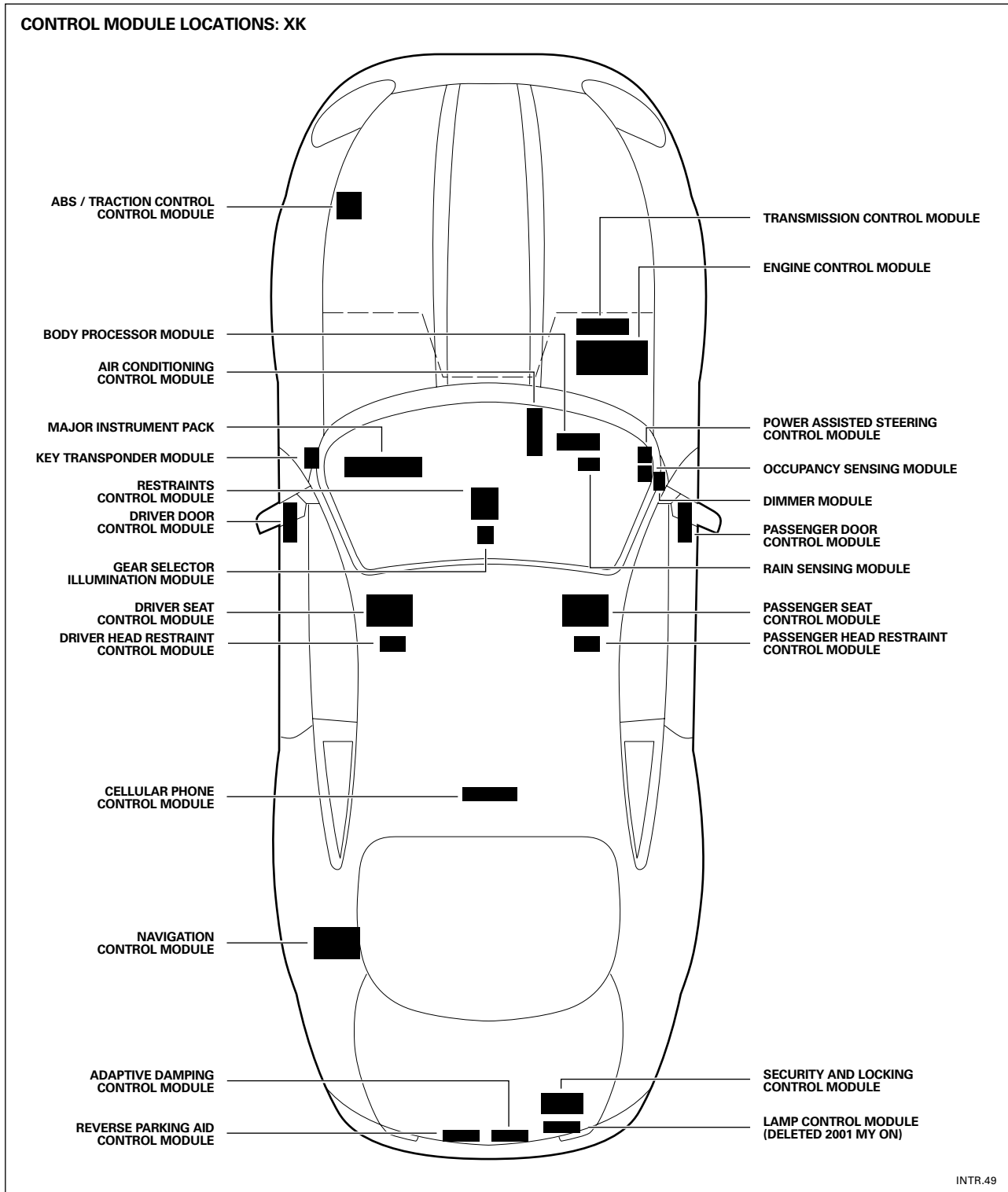

ELECTRICAL DISTRIBUTION SYSTEM

Control Modules (continued)

Vehicle Configuration and Test System (VCATS)

VCATS data has to be supplied to Jaguar for some control module market specific configurations. The data is added to the Control Module at the factory. VCATS matches hardware part numbers with the correct software; therefore care must be taken when exchanging control units from another vehicle for diagnosis.

TYPICAL VCATS LABEL

JAGUAR VCATS
10/09/96
VIN. 003706
PSM. LJA2160AF/004
DSM. LJA2160AF/001
PDM. LJA2120AG/001
DDM. LJA2120AG/001
SLM. LJA2600AF/006
IPK. LJA4300AE/001
BPM. LJA2500AG/055
ECM. LJA1410AK/010

ABBREVIATIONS:

PSM	Passenger Seat Control Module
DSM	Driver Seat Control Module
PDM	Passenger Door Control Module
DDM	Driver Door Control Module
SLM	Security and Locking Control module
IPK	Major Instrument Pack
BPM	Body Processor Module
ECM	Engine Control Module

INTR.53

Should a similar, but not identical, CM from one vehicle be installed in a second vehicle, this may result in various malfunctions in the second vehicle. Since the CM may then 'learn' information from the second vehicle, incorrect data would then be transferred back to the first vehicle when the CM is transferred back to its original location. This is particularly applicable in the case of the Engine Control Module (ECM).

With the increasing number of control units on a given vehicle, it is becoming less cost effective to have replacements pre-programmed at the factory, also the space required to store all market configurations becomes prohibitive. WDS is the main tool for programming and with the latest CD updates it will include the latest software for the vehicle control modules (the CD release notes should be read to see the scope of programming and what vehicles it affects).

NOTES

Networks

Three data networks are employed: a high speed Controller Area Network (CAN) for the engine, drive train and related systems, a Standard Corporate Protocol network (SCP) for the body systems, and an Audio Control Protocol network (ACP) for certain In-Car Entertainment and Telephone functions. Any vehicle subsystem with the CAN or SCP included uses data derived from the network, or transmits data via the network to achieve control. In addition to the two networks, the vehicle uses a Serial Data Link (ISO 9141) for diagnostics and for the programming of certain control modules.

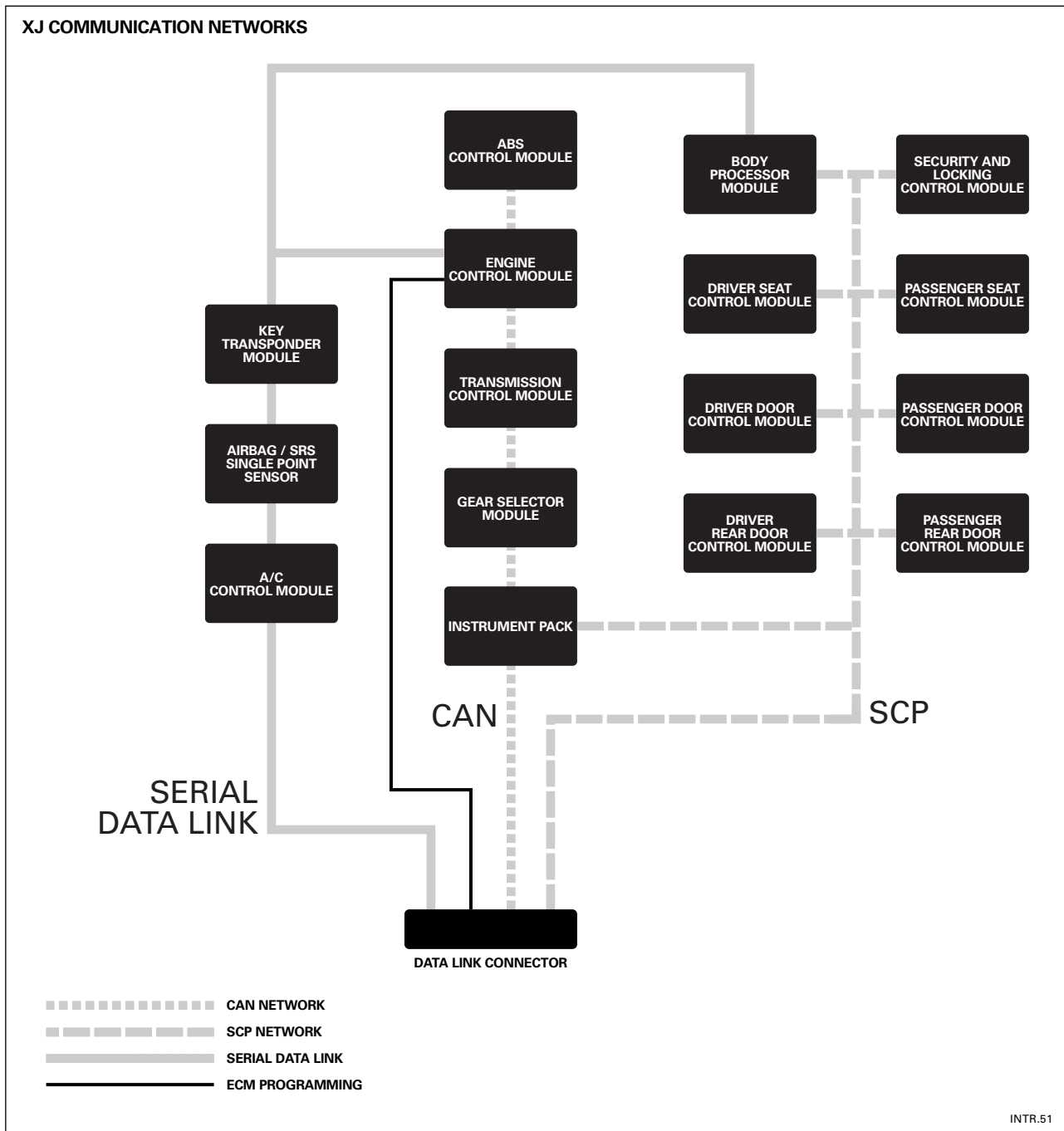

ELECTRICAL DISTRIBUTION SYSTEM

Networks (continued)

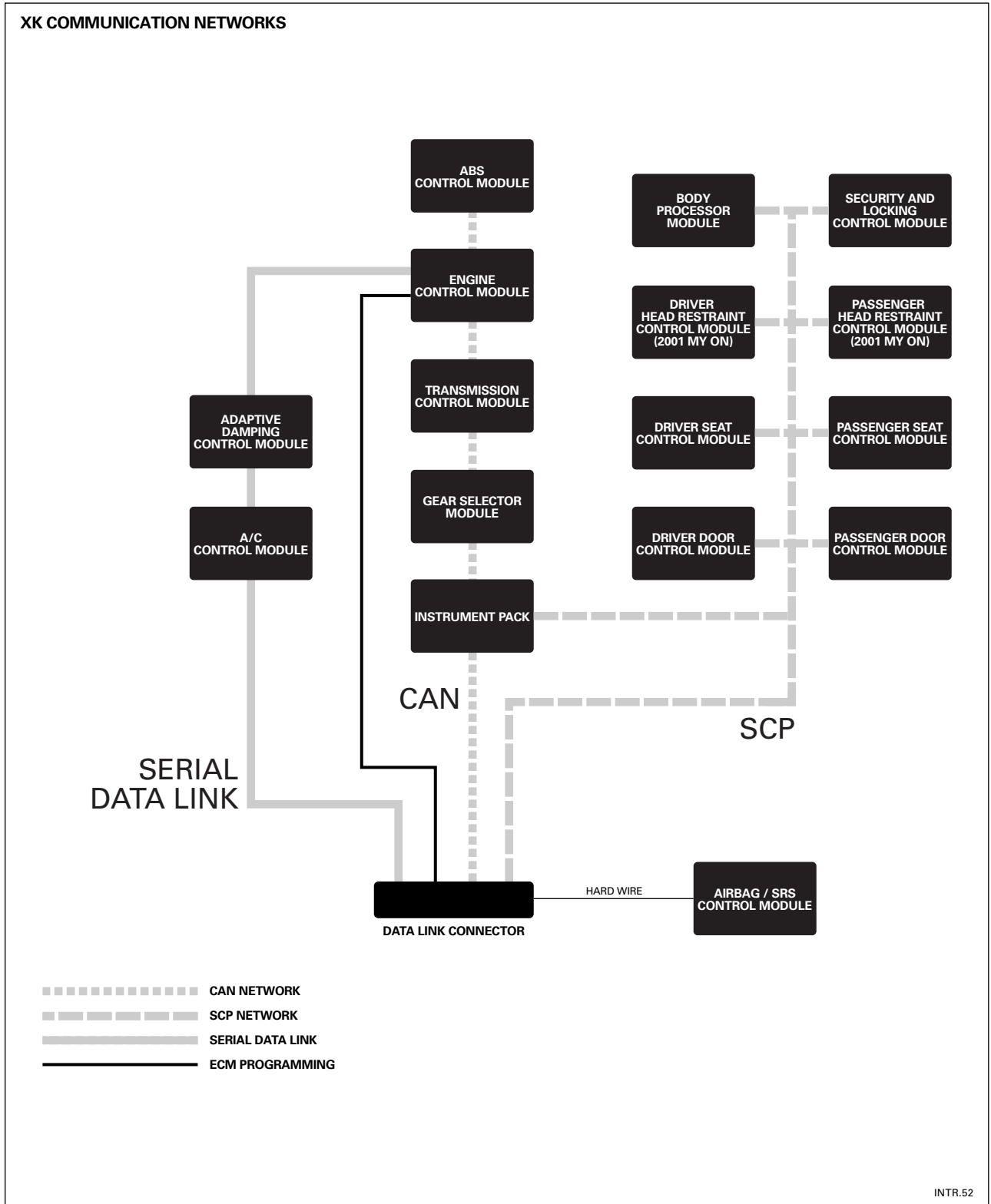

INTRODUCTION TO JAGUAR

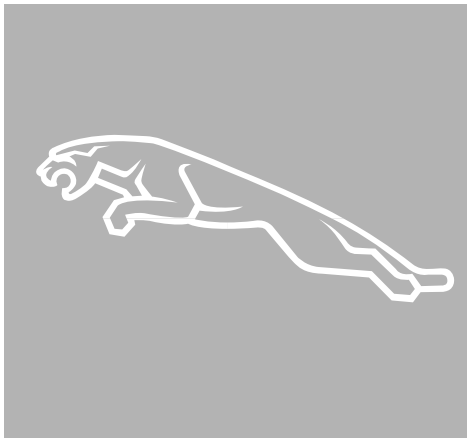

1 INTRODUCTION TO XJ/XK

- 1.1 Overview
- 1.2 Engine
- 1.3 Engine Management
- 1.4 Transmissions
- 1.5 Suspension, Steering and Brakes
- 1.6 Climate Control
- 1.7 Electrical Distribution System

1.8 Body Systems

- 1.9 Occupant Protection
- 1.10 Task Sheets

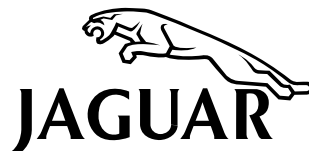

BODY SYSTEMS

Exterior Lighting

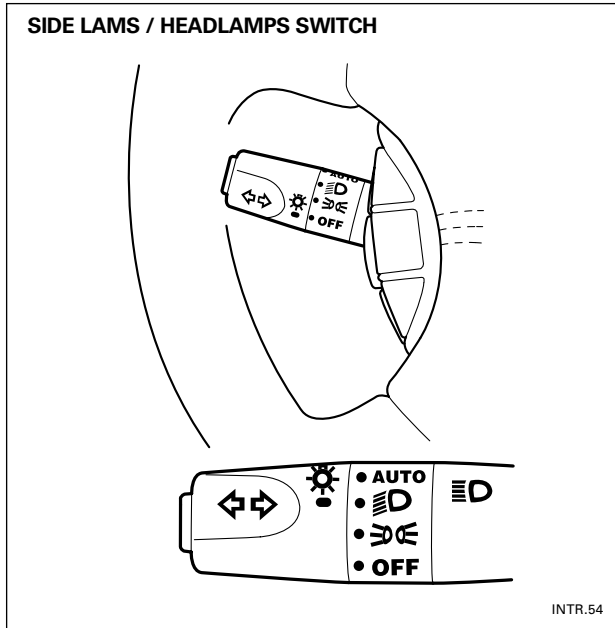

Operation

The controls for the side lamps, headlamps and turn signal lamps are on the left stalk of the column switch assembly. The side lamps operate with the ignition on or off. The headlamps operate only while the key is on; if the ignition is switched off with the headlamps selected on, the headlamps go off but the side lamps remain on. For the auto headlamp function, introduced as standard to XJ/XK in 1998 MY, a light sensor in the interior rear view mirror monitors ambient light and signals the BPM to switch the low beam headlamps on and off as appropriate for the prevailing light conditions. The automatic function is selected by setting the side lamps/headlamps switch to AUTO. An adjuster on the sensor allows the switching point to be adjusted to different light levels. A delay in the BPM prevents “hunting” between the on and off states.

NOTES

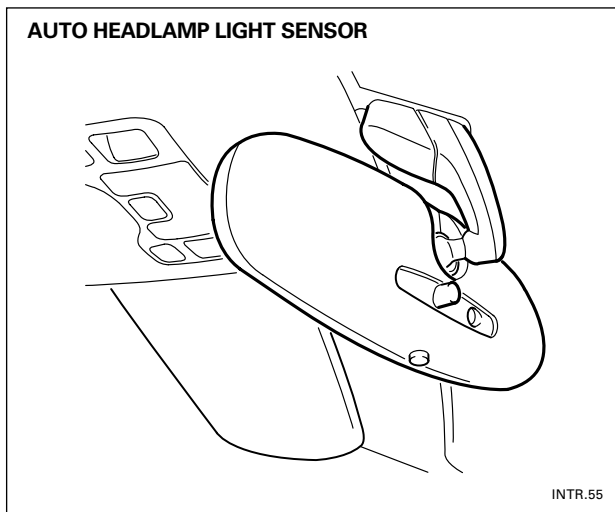

The front and rear fog lamp switches are non-latching push switches installed on the fascia, left of the instrument cluster (XJ), or on the center console switchpack (XK). The front fog lamps only operate when the side lamps or headlamps are selected on; they go off when the headlamps are set to high beam.

The rear fog lamps operate only when the headlamps or side lamps and front fog lamps are selected on.

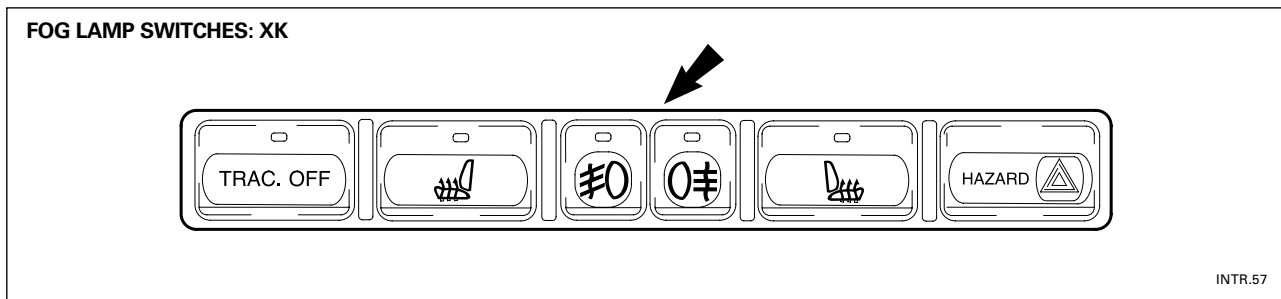
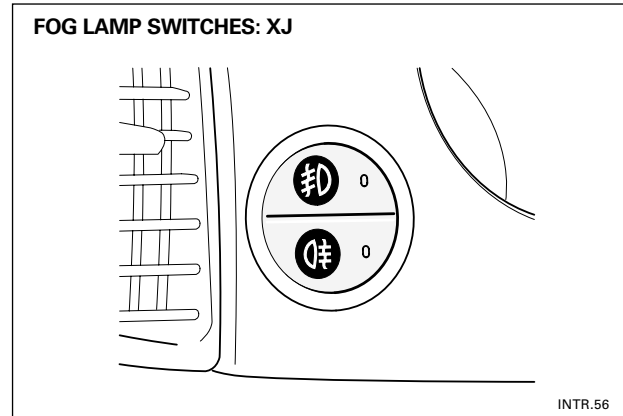

NOTES

BODY SYSTEMS

XJ Exterior Lighting

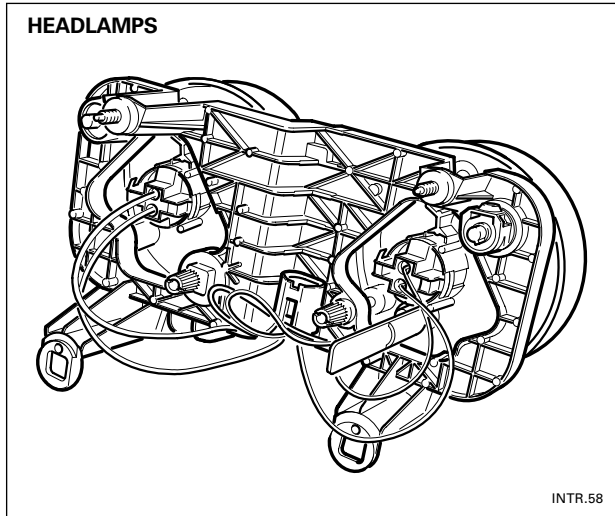

Headlamps

Plain lenses are introduced on all four headlamps, and the facets that help to shape the light beams are now incorporated in the reflectors. The side lamp bulbs are moved from the outboard (low beam) lamps to the inboard (high beam) lamps. This maximizes the reflector surface available for control of the low beams, which is more critical than that of the high beams.

The headlamp and side lamp bulb are installed in bulb holders which are a push fit in the reflectors. The headlamps incorporate H7 bulbs. Light output from the new headlamps is 10% greater than from the previous design.

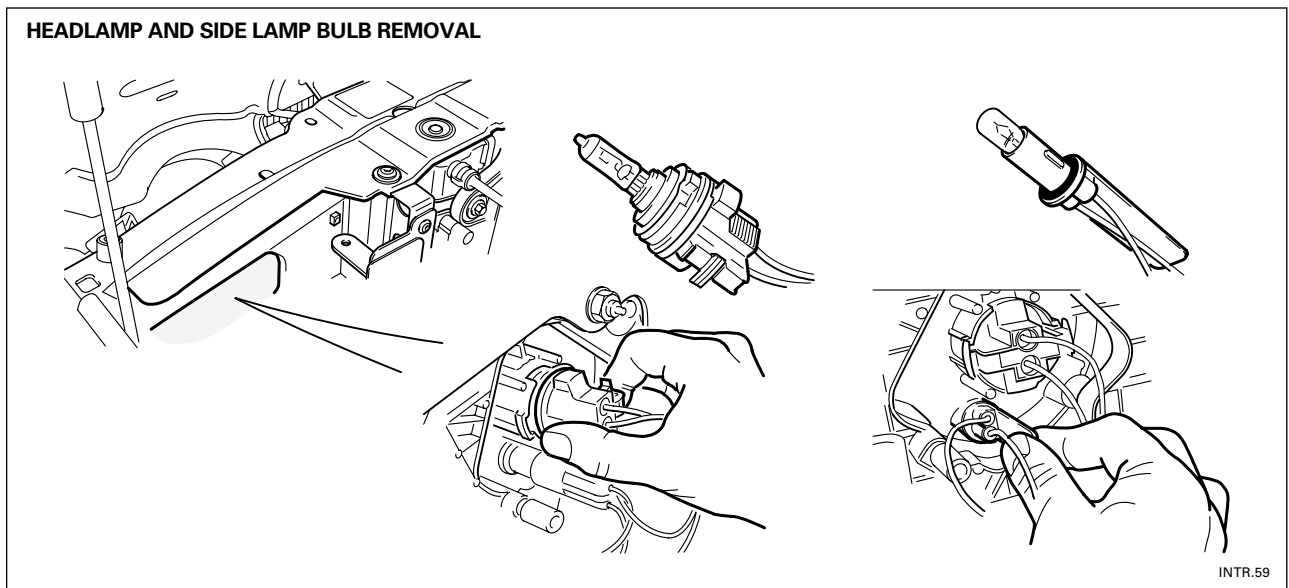

NOTES

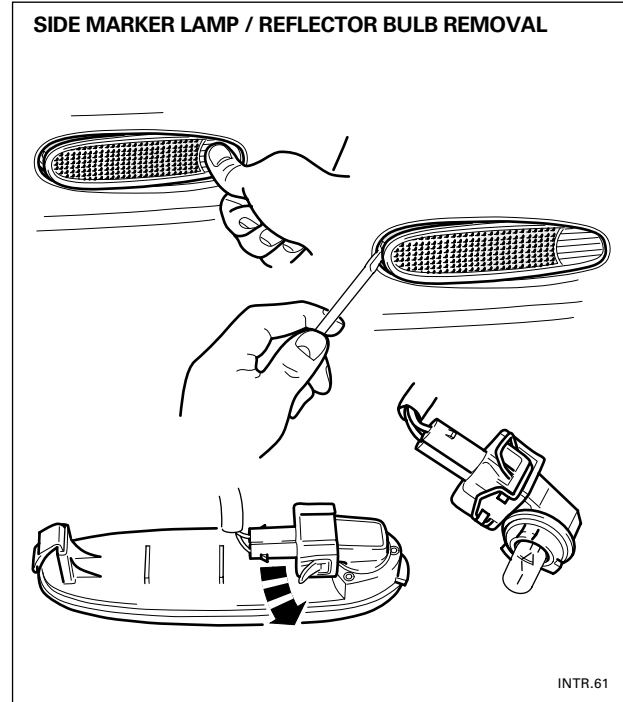
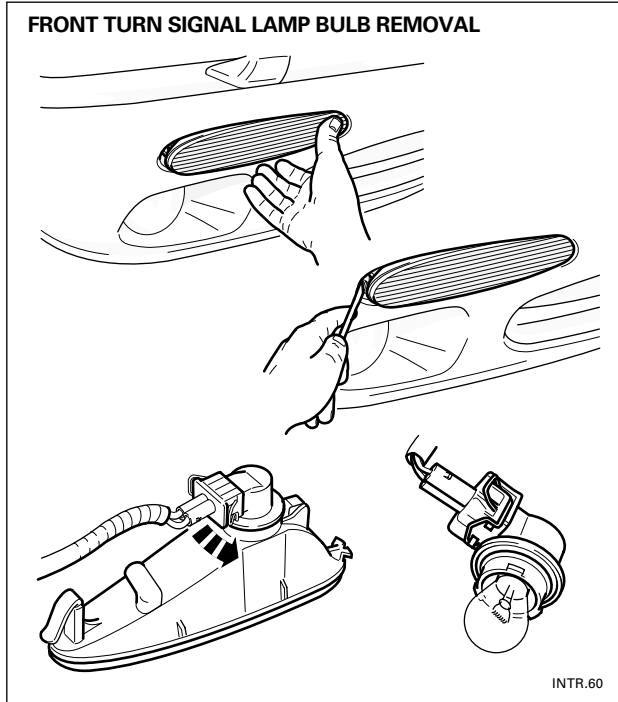

NOTES

BODY SYSTEMS

XJ Exterior Lighting (continued)

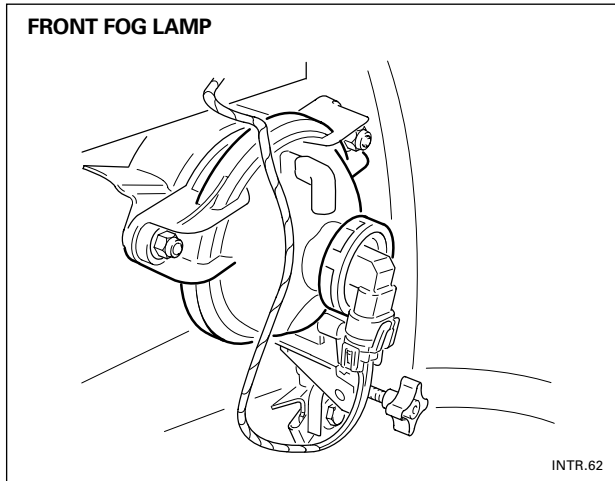

Front Fog Lamps

The two front fog lamps are identical. Three screws secure each lamp in a recess in the front bumper. The lamps incorporate plain lenses and free form reflectors (free form reflectors provide sufficient control of the light beam that it is unnecessary to have facets on the lens or reflector).

The fog lamps incorporate HB4 bulbs installed in bulb holders which are retained in the reflector by a bayonet lock. An adjuster for vertical alignment is incorporated in the lamp housing. Access to the lamps is from the rear of the bumper.

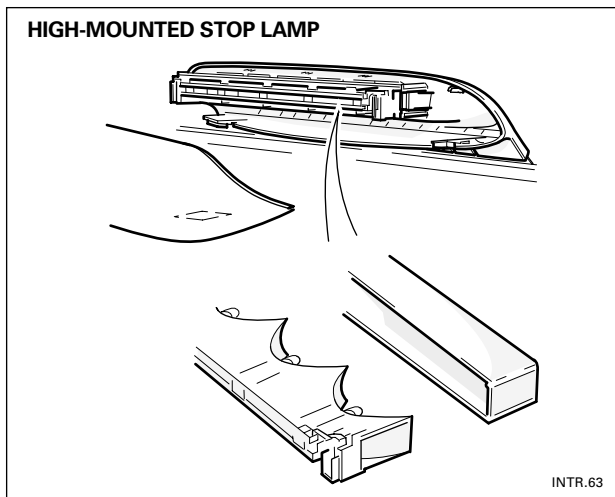

High-Mounted Stop Lamp (HMSL)

The HMSL attaches to studs on the center lower edge of the backlight. Inside the cover, five bulbs are installed in the reflector, which clips onto the base. The lens clips into the reflector.

To remove the HMSL complete, access is required to the bottom edge, where the latching feature on each clip must first be released before lifting the unit up the back light.

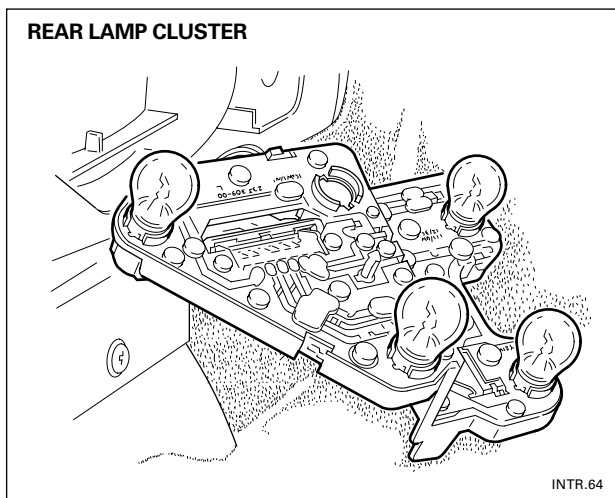

Rear Lamp Cluster

The vertical faces are deleted from the lens and incorporated into the reflector. The individual tail bulb is deleted, the tail lamp being provided by the combination stop/tail bulb.

NOTES

XK Exterior Lighting

Headlamps

The headlamps incorporate the high and low beam headlamps, the front turn indicator lamps and the side lamps. Each headlamp is secured to the body by two screws and a nut. A rubber gasket around the periphery of the lens seals the headlamp with the body. Clips secure the lens to the lamp housing and a rubber gasket seals the interface. The housing contains four separate bulbs:

- H1 55W low beam headlamp bulb, retained by a spring clip
- HB3 65W high beam headlamp, retained by a spring clip
- W 5W side lamp bulb, in a bulb holder
- PY 21W front turn indicator lamp bulb, in a bulb holder

Circuits integrated into the housing link all the bulbs and bulb holders to a single connector on the rear of the housing. All bulbs, except high beam, are long life bulbs.

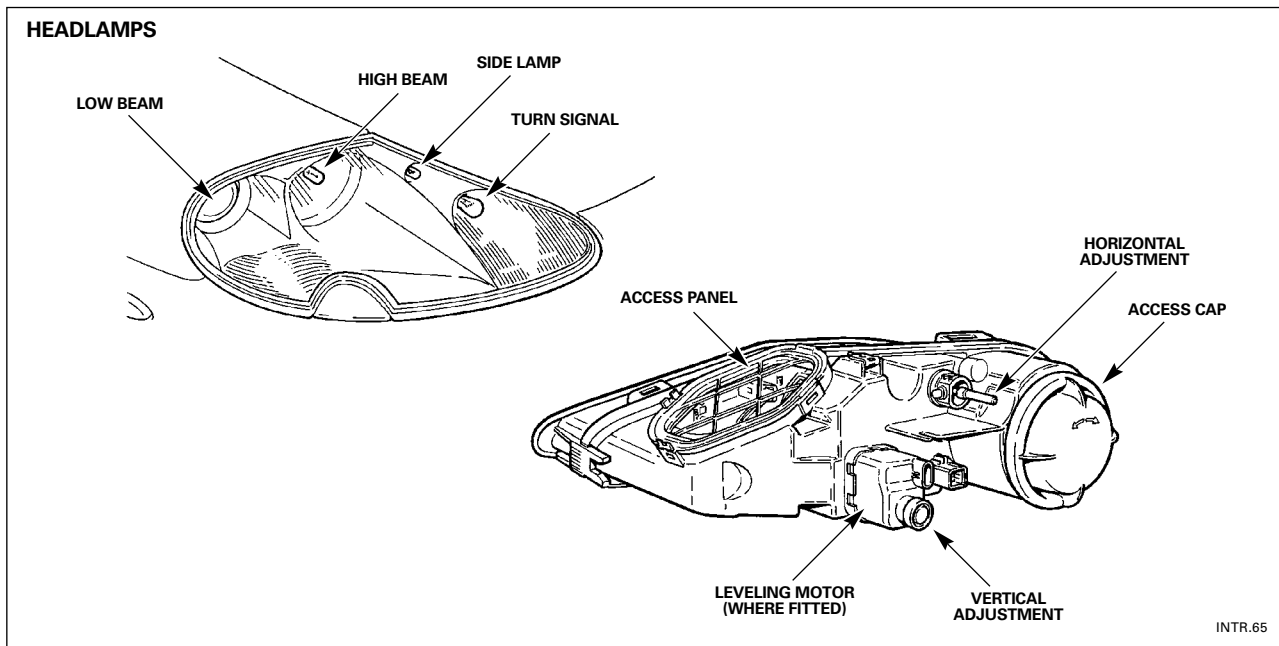

Headlamp Adjustment

Adjusters for horizontal and vertical alignment are on the rear of the housing. To enable roadside alignment checks, headlamps contain an adjustment scale, visible through a clear plastic panel on the inboard side of the housing.

Removal of the clear plastic panel provides access for replacement of all bulbs except for the low beam headlamp bulb. The cap on the rear of the housing, accessed through the panel in the wheel arch liner, provides the access for the low beam headlamp bulb.

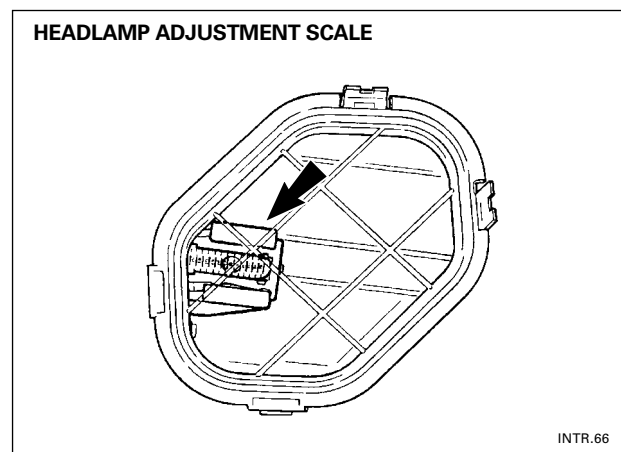

BODY SYSTEMS

XK Exterior Lighting (continued)

FRONT FOG LAMP (1997 – 200 MY)

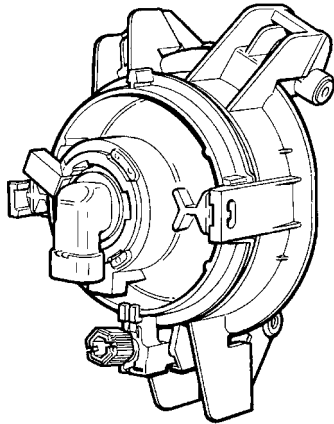

INTR.66

Front Fog Lamps

The front fog lamps are installed in recesses in the front bumper. Three screws secure each fog lamp. Due to the orientation of the securing holes, the lamps are not interchangeable.

Each lamp has an adjuster for vertical alignment (only) and an H1 55W bulb installed in a bulb holder. Access for adjustment and bulb replacement is through the panel in the wheel arch liner.

High-Mounted Stop Lamp (HMSL)

The HMSL is installed on the backlight (coupes) or trunk lid (convertible) for some markets and consists of a lamp unit and a cover. Clips secure the cover to the lamp unit. On coupes, clips secure the lamp unit to the backlight. On convertibles, three nuts secure the lamp unit to the trunk lid.

Each lamp unit contains 16 non-replaceable LED wired to a single connector. The lamp unit must be replaced after failure of 1 LED maximum.

FRONT FOG LAMP (2001 – 2002 MY)

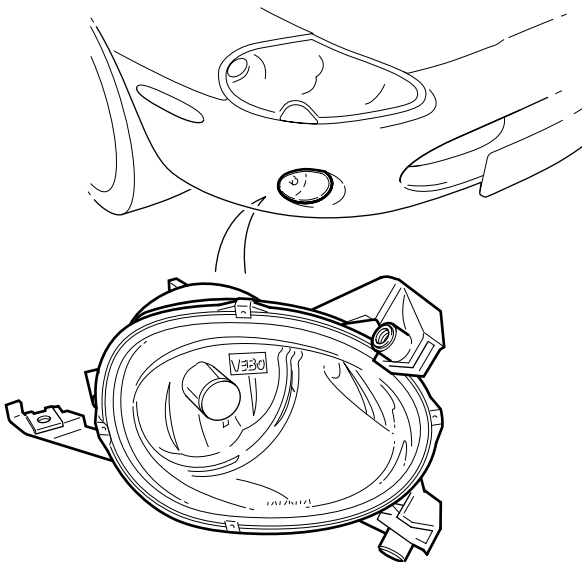

INTR.67

NOTES

Rear Lamp Clusters

The rear lamp clusters incorporate the reverse lamps, rear fog lamps, tail lamps and stop lamps. The upper part of the lens is clear and the lower part is red. The area of the lens over the tail lamp incorporates a reflector.

The removable bulb carrier contains all bulbs. Two releasing clips retain the carrier for 1997 – 2000 MY; 2001 – 2002 MY carriers are retained by a single wing nut.

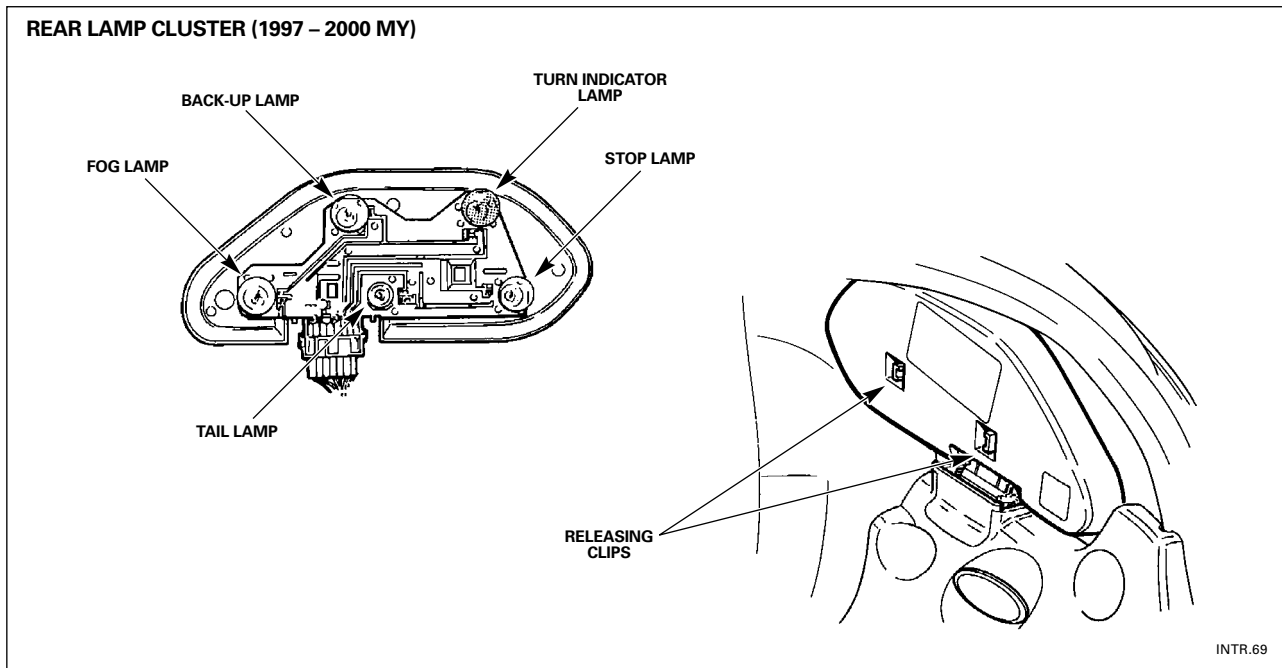

NOTES

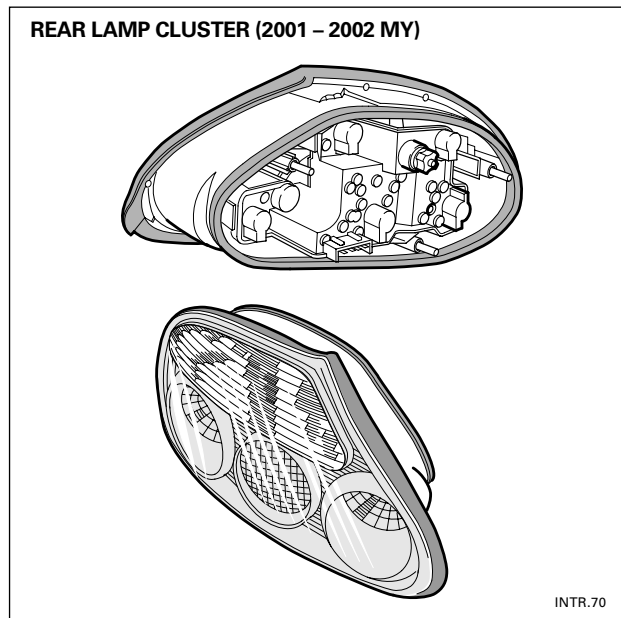

BODY SYSTEMS

Convertible Top: XK only

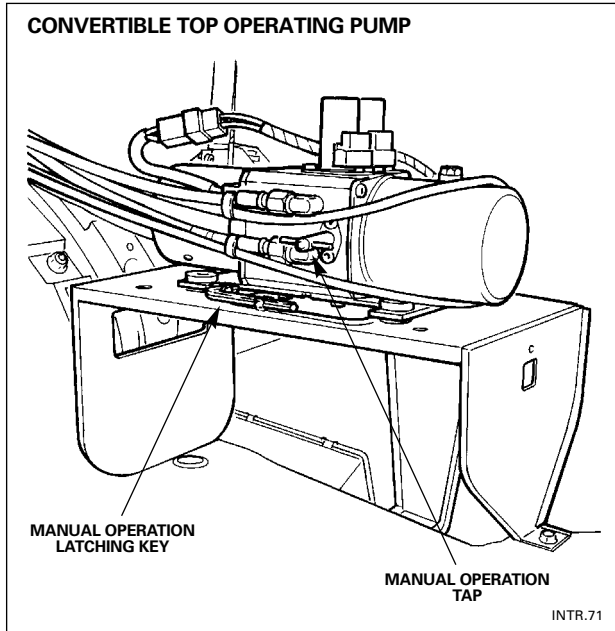

Introduction

The convertible top is fully lined and padded and fitted to an aluminum frame which has steel linkages. Hydraulic power is used to open, close and latch the top, operated by a single hold-down switch (ROOF) on the center console. This switch also operates the rear quarter lights. The top closes to a low stack height in the body opening of the rear quarter. A green tinted, heated, glass backlight is fitted as part of the top. A new feature is over-center linkage pivoting on the rear wheel arch to hold the top forwards during the latching and unlatching operations.

CAUTION: It is imperative that the procedure for manual latching/unlatching of the convertible top is read before any moves are made to unlatch the top, (see Manual Latching).

Operating Pump and Hoses

The convertible top operating pump is located in the right-hand side of the trunk mounted on a steel pressing, which also houses the CD player and power amplifier units (where fitted). This operates at a pressure of 140 bar (2030 psi) maximum and is equipped with valves and cylinders to operate the two actuators and the latch mechanism. The high pressure hoses are routed through the rear bulkhead to each of the actuators. The latch hoses pass across the rear seat pan and the right heelboard and up the 'A'-post into the latch plate assembly.

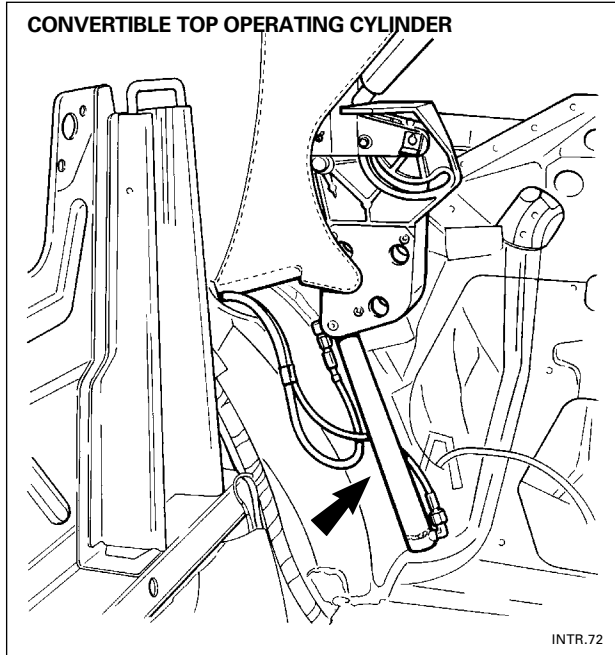

NOTES

Automatic Latching

WARNING: Ensure that the convertible top cover is removed and that all personnel and equipment are clear before the convertible top is raised or lowered.

The latching system is supplied as a complete unit and has no serviceable components. Latching of the top is by a hydraulically operated center pull and latch mechanism and two outboard latches. The latch mechanism automatically pulls the top onto the body header and latches it into position. When the top is not latched, an unlatched warning appears on the message center display.

Operation of the convertible top is inhibited, or, if the top is moving it will retract to the lowered position, if the vehicle exceeds 16 km/h (10 mph). The ROOF NOT LATCHED warning will be displayed on the message center until the next actuation.

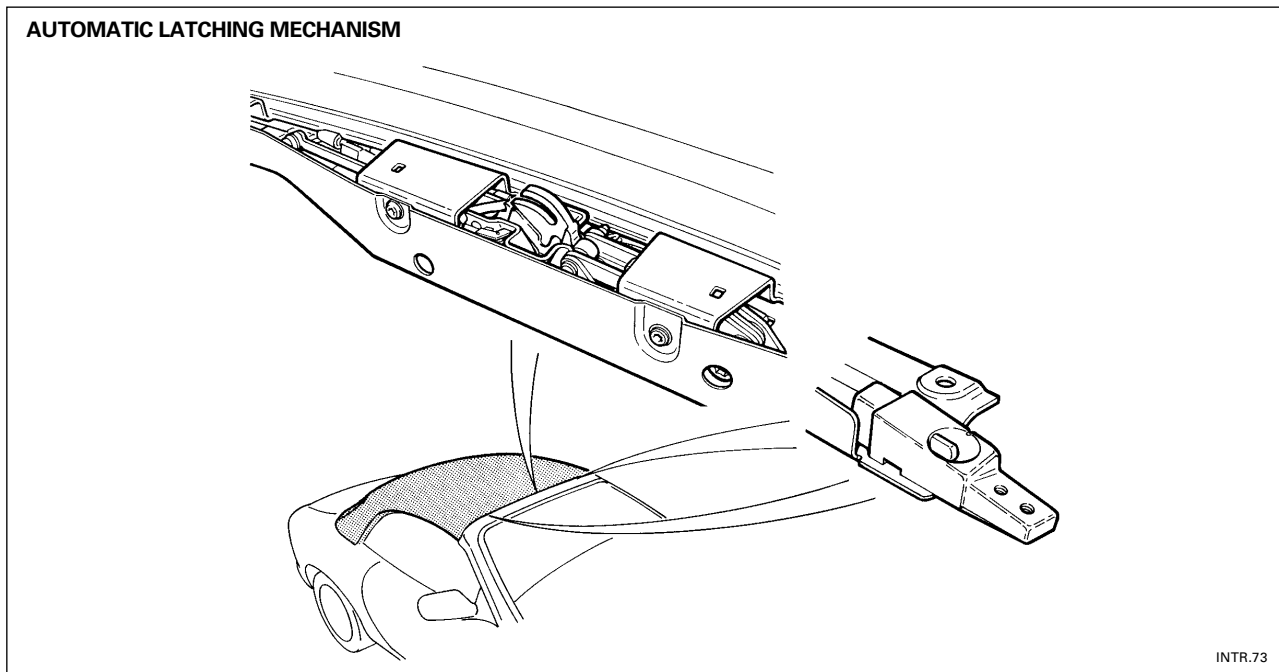

The convertible top operating ROOF switch must be held to be activated. Short presses of the switch operate the rear quarter lights without operating the top. The operating switch will only activate the top if the ignition switch is in either position I or II.

As soon as the top starts to move an audible warning will sound. Raising and lowering of the convertible top is controlled on the SCP network.

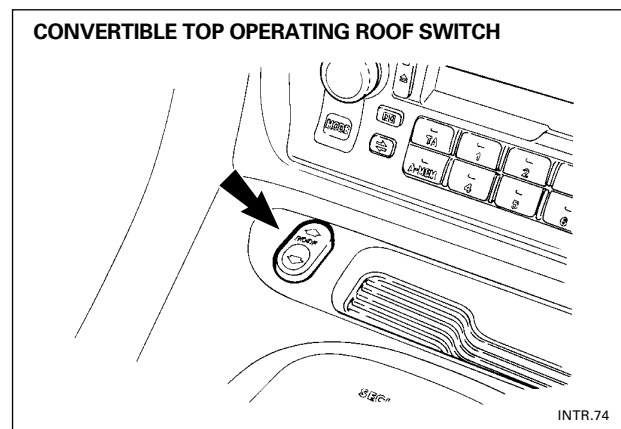

BODY SYSTEMS

Convertible Top: XK only (continued)

Manual Latching

In the event that the top cannot be powered to the raised or lowered position, provision is made for manual operation.

NOTE: The convertible top frame uses an over-center link to lock the frame in its forward position. It is essential to carry out the following procedure to manually lower the vehicle convertible top. Because of the possibility of damaging the frame, manual lowering of the convertible top is only recommended as a Dealer function and not an Owner/Driver function. Manual lowering has been deleted from the Driver Handbook.

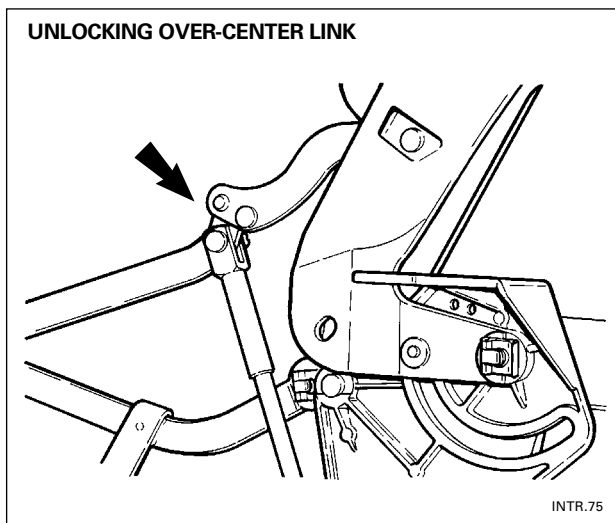

1. Lower the rear quarter lights by pressing the ROOF switch once.
2. Gain access to the pump located in the trunk, (the right hand side trunk trim carpet must be removed for access to the pump) and turn the manual override tap on the pump body counterclockwise to place the pump into MANUAL mode.
3. The windscreen header trim has a small round plug, adjacent to the header console, which has to be removed to gain access to the latching mechanism. Insert either the key which is retained in clips on the pump mounting base, or an 8mm Allen key, and unlatch the hood by turning the key clockwise.

CAUTION: Do not attempt to lower the convertible top further at this stage.

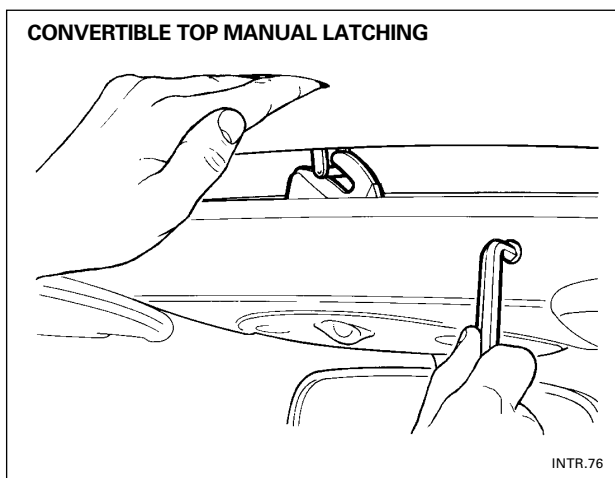

4. Prior to lowering the hood, reach behind the headlining rear quarter curtains and locate both of the convertible top cylinder rams and the linkage to which they are fixed.
5. Pull, in turn, both the left and right hand cylinders and linkage down as far as possible. A significant force may be required.
6. Manually lower the top to its stowed position. (If the hood resists movement repeat step 5).

CAUTION: Failure to carry out steps 4 and 5 will result in severe damage to the convertible top frame and/or linkages.

NOTES

Door Glass Movement

The door glass is operated by the DDCM and the PDM from the switchpacks located in the driver and passenger door arm rests. The switchpacks are illuminated when the sidelights are on.

- Each door glass automatically drops 15 mm (0.65 in) when the door is opened and closes when the door is closed.
- The glass of both front doors will drop when the convertible top is raised and close when the top is full raised and latched in position.
- Each door glass has a one-touch down facility.
- If the key barrel lock switch is held active for more than 1.5 seconds then the door glass and the convertible rear quarter light glass will be driven closed unless the key is released.

The glass in both doors operate with the ignition switch in either position I or II and for 30 seconds after ignition is switched off or until a door is opened.

Resetting Door Glass Position

If the power supply to the DDCM or PDM is disconnected (battery disconnected, module unplugged or fuse removed) or a PDU or scan tool is connected to the ISO connector and diagnostic checks are made, then the modules must relearn the glass characteristics.

The last known glass position is regarded as top of travel by one touch operation until relearning has taken place. One touch down, manual up and down control and the automatic lowering of the glass for door opening are unaffected. For the control module to learn the glass characteristics the door must be closed (door ajar switch inactive and the ignition switch in position I or II) then drive the glass fully down and hold it stalled at the bottom of its travel for a minimum of one second. Drive the glass fully up and hold stalled for a minimum of one second. The relearning procedure must also be accomplished before automatic glass closing is allowed.

CAUTION: With the transit relay fitted, do not operate more than one door glass at a time.

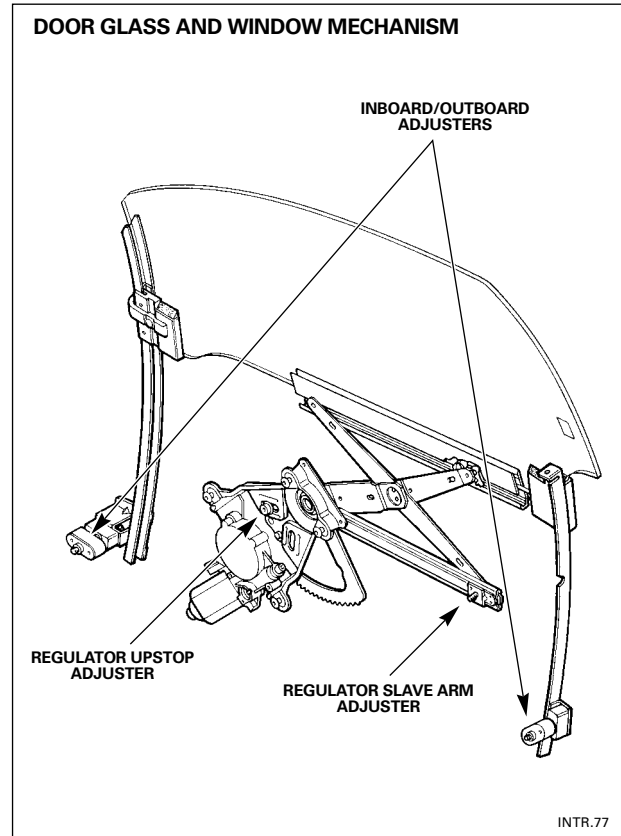

NOTES

BODY SYSTEMS

Security Systems

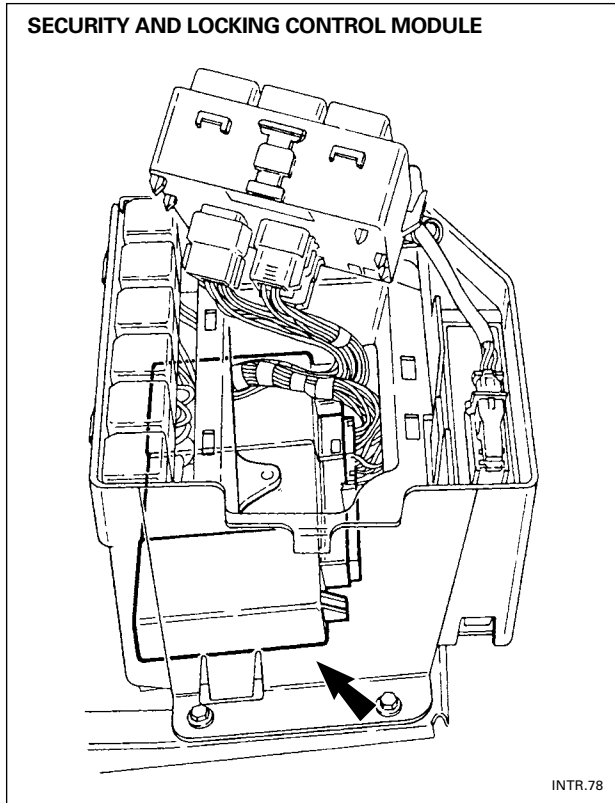

The following security features are available:

- Panic alarm (dealer option)
- Passive arming (dealer option)
- Audible warnings
- Security LED in gear selector surround
- Drive away door locking
- Key and remote transmitter locking/unlocking
- Remote headlamp convenience
- Remote trunk open

The security and locking systems involve the SLCM, BPM, DDCM and PDCM all connected via the SCP network.

The SLCM is located in the electrical carrier below the fusebox, in the trunk. The BPM is mounted off the passenger airbag bracket, behind and above the glove box. DDCM and PDCM are located in the doors.

Anti-Theft System

Full Alarm

Once armed any of the following circumstances will create a full alarm state and the sounder will operate (if fitted):

- Opening a door (after seven seconds)
- Opening the trunk with the key (after seven seconds)
- If the ignition key is turned to position I
- Pressing the key-ring transmitter headlamp button three times - Panic Alarm
- Opening the hood
- Glass breakage (if sensor is fitted).

Error Tone

The sounder gives a short, high-pitched warble if an attempt is made to secure the vehicle and one of the following conditions is present:

- The trunk is not closed when an attempt is made to arm the security system
- The key is in the ignition switch when a transmitter button is pressed
- If there is a failure within the alarm system the error tone will sound when the vehicle is disarmed
- If any door or the hood is open when an attempt to arm the security system is made.

Key-ring Transmitter

A four-button, rolling code, key-ring transmitter gives remote control of the system. Two key-ring transmitters are supplied with each vehicle.

Button functions are as follows (numbers correspond to those in the illustration at right):

1. Locks and arms the vehicle.

One press will lock both doors and the trunk and will set the alarm system. One signal will be heard and the direction indicators will flash once. The LED in the gear selector surround will continually flash whilst the vehicle is armed.

2. Unlocks and disarms the vehicle.

If the car is in a locked state, at the first press of the button the driver’s door only unlocks and the interior lights fade on. A second press unlocks the passenger door.

3. Switches on the headlamps and starts the panic alarm.

One press switches on the dipped headlamps which remain on for 25 seconds or until the button is pressed a second time or until the key is inserted in the ignition switch. Three presses within three seconds starts the panic alarm. The alarm will sound for a full period and can only be stopped by inserting the key into the ignition and turning to positions I or II. The transmitter cannot be used to cancel the panic alarm.

4. Releases the trunk lock.

One press releases the trunk lock, without disarming the system.

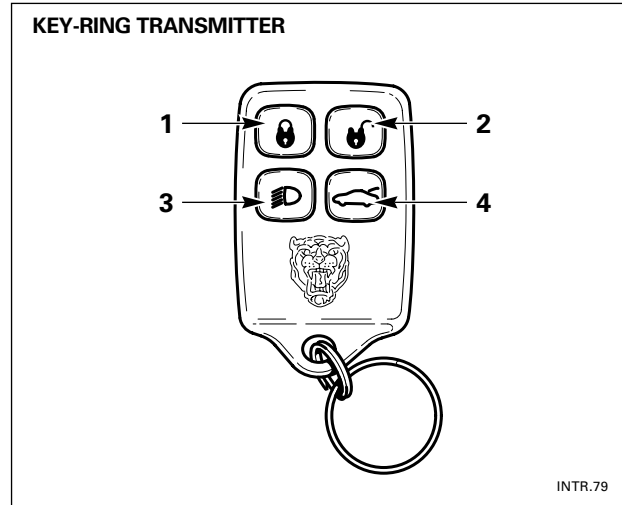

The key-ring transmitter will only work if the vehicle’s doors, hood and trunk are closed and the key is not in the ignition. Dealers are required to obtain proof of ownership before issuing a replacement transmitter. Batteries for the transmitter are CR 2016.

Key-ring Transmitter Programming (Manual Procedure)

- Insert Ignition Key
- Hold Headlamp Stalk Switch active (headlamps ON)
- Turn Ignition Key to position 1 (Auxiliary)
- Flash Headlamp Switch: 3 times for 1997 MY vehicles or 4 times for 1998 MY vehicles
- Confirmation chirp will sound and LED will flash once to indicate “Learn Mode” has been entered
- Activate each Remote Transmitter by pressing any button on the transmitter once – a chirp will sound for each Remote Transmitter signal received (LED will flash); allow 15 seconds maximum between each press
- Switch ignition off – confirmation chirp will sound to indicate “Learn Mode” has been exited (system will automatically “time out” after 15 seconds)

BODY SYSTEMS

Security Systems (continued)

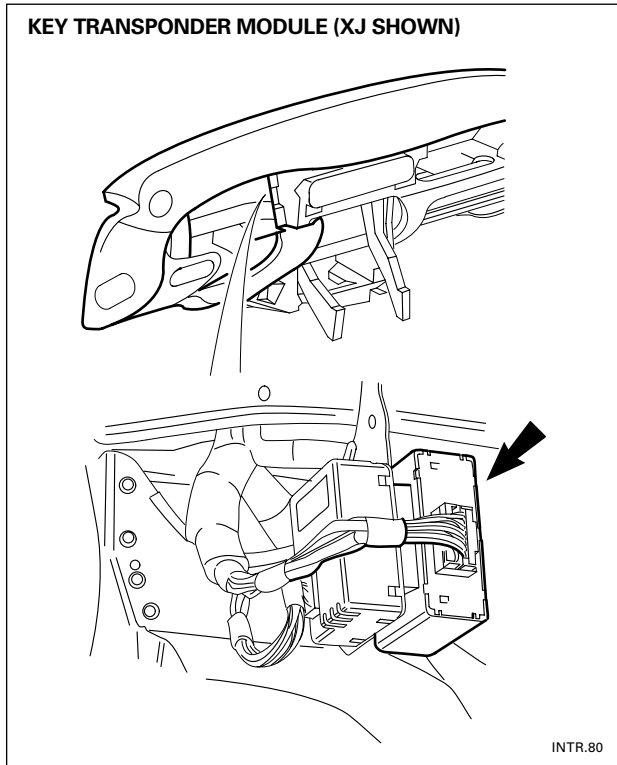

Key Transponder Module (KTM)

Engine immobilization is introduced. The engine immobilizer ensures the engine can only be started using a valid ignition key. A key transponder control module, installed in the fascia next to the control column, is linked to the BPM, the ECM and a reader/exciter coil around the ignition switch. The KTM is programmed to recognize a uniquely coded transponder in the head of each key supplied with the vehicle. When a key is installed in the ignition switch and turned to position I (auxiliary), the KTM uses the reader/exciter coil to read the transponder code. When the key is turned to position II (ignition), the KTM exchanges signals with the BPM and ECM and, if the key is valid, fueling, ignition and cranking functions are enabled to allow the engine to start when the key is turned to position III (crank). If the key is invalid, the fueling, ignition and cranking functions are inhibited and the engine cannot be started.

Replacement keys are programmed using WDS.

NOTES

Ignition Key Transponder Programming Using WDS

If the KTM is replaced, all keys must be programmed at the same time. No more than 5 keys can be programmed to any one vehicle. If only the ECM is replaced, key transponder programming is not necessary.

1. Ensure all of the vehicle's keys are available for this procedure. No more than 5 keys can be programmed to one vehicle.
2. Load the latest software for the vehicle into WDS.
3. Access Vehicle Setup.
4. Select Security System Setup.
5. Select Program New Transponders.
6. Ensure that only the key being programmed is in the ignition. (Remove key from a ring with other keys. If other Jaguar keys are near the reader exciter, they may also be detected, which will cause the KTM to interpret this condition as an invalid signal).

NOTES

BODY SYSTEMS

In-car Entertainment (ICE)

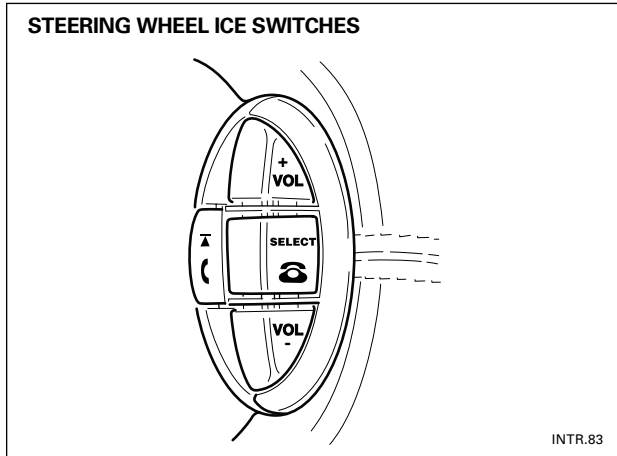

XJ/XK vehicles are equipped with either a base or premium entertainment system. The premium system uses the same audio unit and antenna as the base system, but includes a power amplifier and different speakers. Both systems have switches on the steering wheel for remote operation. Telephone controls are incorporated in the audio unit of all vehicles, although the telephone system itself is an accessory. In 2000 MY, the XJ was fitted with a dual function audio unit which incorporates the navigation system controls and a shared radio/navigation LCD display. The XK audio unit was also revised, but remains visually the same due to a separate navigation display/control panel.

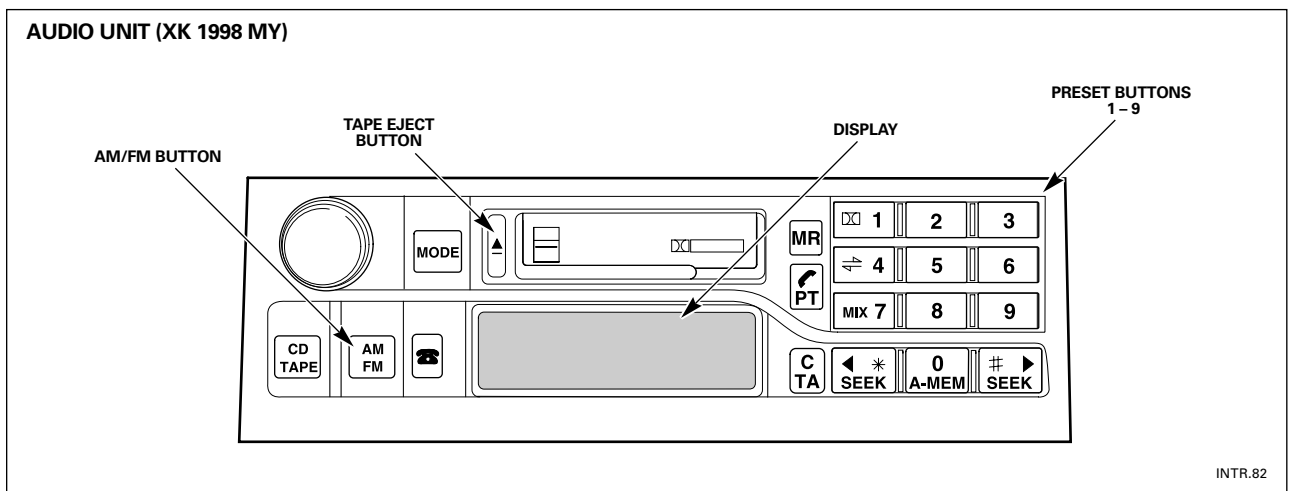
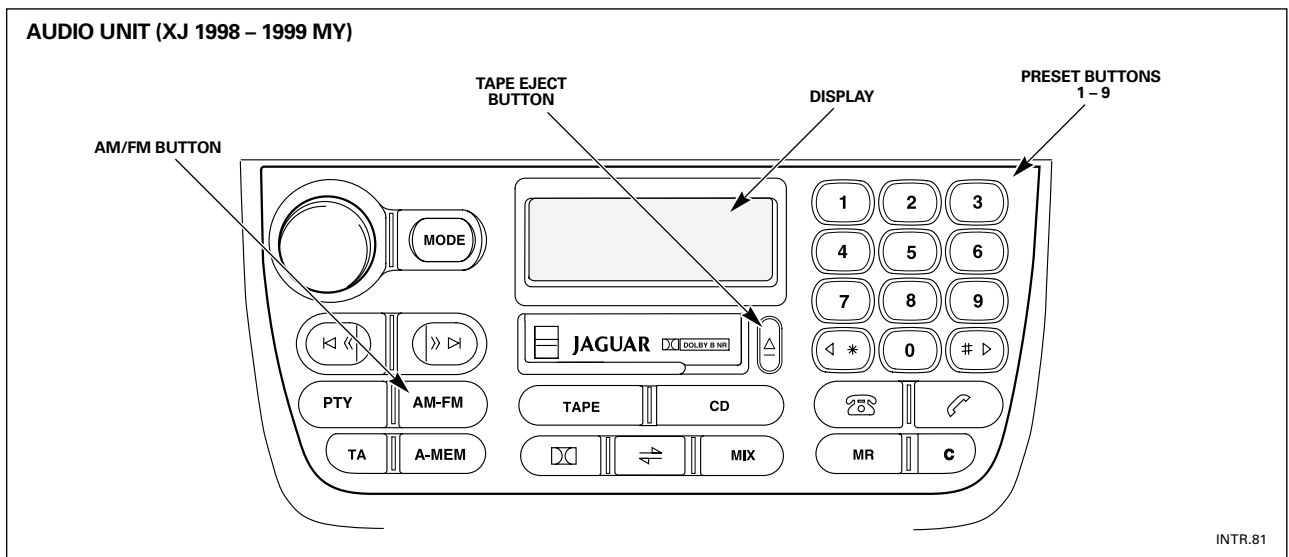

Selecting Radio Features

To access the selectable features, simultaneously press the AM/FM button and the tape eject button. The radio will display SET UP MODE. The following set up modes can then be selected and changed in any order, as long as no more than 15 seconds elapses between presets. After 15 seconds the display will clear. If additional mode changes are needed, re-enter the set up mode. To select a feature, press the applicable preset button.

- Preset 1** Press preset 1 to select the market mode to suit the users country and Radio Data System (RDS) ON/OFF. (RDS is being introduced by some radio stations.)
- Preset 2** Toggles the tape head cleaning service reminder off and on. (Should be ON)
- Preset 3** Toggles the clean aerial service reminder off and on. (Should be ON)
- Preset 4** Toggles the cellular telephone function off and on. If a Jaguar telephone is installed, turn the telephone function on by pressing the reset 4 button until TEL ON shows on the display. (Should be ON)

NOTE: If a hands-free cellular telephone is installed, the mute function must be switched ON.

- Preset 5** TAPE EJE ON/OFF – sets the cassette tape to automatically eject when the ignition key is turned off.
- Preset 6** Not used.
- Preset 7** DIVERSITY ON/OFF – Used when a Diversity Antenna System is connected to the radio. (Should be OFF because the system is not used by Jaguar.)
- Preset 8** AF ON/OFF – (Alternate Frequency) Used when reception problems occur with RDS stations. Toggling AF ON/OFF will eliminate program drop-out on RDS channels.
- Preset 9** Not used.

NOTES

BODY SYSTEMS

Navigation System

XJ and XK vehicles may be fitted with optional fully integrated navigation systems which provide various types of route guidance information to aid the driver, using visual displays and voice commands. The navigation system uses signals from the global positioning satellite (GPS) system together with ground map data, vehicle road speed and yaw rate to calculate the position of the vehicle to an accuracy of several metres. After entering the desired destination and route information, the driver is guided by both visual and/or voice instructions and if, for example, a wrong turn is made, the navigation system recalculates the route.

The XJ navigation display and controls are integrated into the audio unit while the XK has a separate integral display and controls panel located in the central fascia. The remaining equipment is common to both types of vehicle and consists of the navigation control module, the GPS antenna and the vehicle speed module. Map and associated data for a particular country or region are stored on the new technology digital versatile disc (DVD) which is loaded into the navigation system DVD reader.

System Features

A description of the navigation system facilities and operating instructions is given in the Navigation Handbooks provided with the vehicle. A brief overview of these facilities is provided here.

Destination and Route

Various types of destination information may be input by the driver using screen menus and panel controls to make selections and input text characters. Addresses may be entered or selections made from the DVD database listing 'points of interest' such as hotels, bus stations, amusement parks and other places. Other types of destination which may be requested include road intersections, map cursor locations, recent destinations or local points of interest, that is, locations within a specified radius. As well as this DVD stored data, the user may create 'memory points' which are map locations for subsequent selection as route destinations or way points.

The user can also specify route modifications to a particular destination by defining way points to split a route into sections. After a destination has been selected, roads to be avoided or utilized (e.g. all major highways) may also be specified. Further route parameters include shortest distance or time and re-route calculations.

NOTES

Route Guidance

On XJ vehicles, only the arrow view type guidance display is available, though it may also be shown together with radio/audio information.

On XK vehicles, three types of screen guidance are available: map, arrow view or hybrid.

- The map view shows the relevant map area with the route highlighted and the arrowed vehicle: the map scrolls automatically to keep the vehicle on screen.
- The arrow view shows a diagrammatic display: as the vehicle approaches the next manoeuvre point, a detailed view of the junction is displayed with a direction arrow and distance information.
- With hybrid selected, the map and highlighted route are shown until a manoeuvre point is reached when the arrow view appears.

Voice Guidance

A main feature of the navigation system is the synthesized voice guidance which enables the driver to receive verbal instructions about the next manoeuvre (e.g. 'turn left'). A button on the control panel allows the user to ask the system to repeat the last instruction. The voice guidance instructions are broadcast via the audio system and may be adjusted using the MODE buttons and volume controls on the audio unit. The settings available allow the relative balance of volume between voice guidance and audio system to be varied.

Clock

A digital clock is displayed in the lower left-hand corner of the screen and is in 12-hour format. The correct time is maintained automatically from the GPS satellite signals and no adjustment is provided. Time zone and summer time settings are selectable via a screen menu and must be adjusted according to vehicle location and time of year.

NOTES

BODY SYSTEMS

Navigation System (continued)

XJ Navigation Display and Controls

The XJ navigation controls and screen display are integrated with the audio unit which is physically similar to the previous unit. The LCD screen shows navigation and/or radio and audio information and is displayed in mono-chrome only. Navigation system controls are to the left of the screen and are as follows:

- Volume control (A) – adjust audio system volume and audio/navigation voice guidance balance
- MODE button (B) – select navigation volume adjust (also audio system sound effects)
- CLEAR (C) – return to previous menu, character or text: clear screen at end of route
- Four cruciform scroll keys (D) – cursor up/down and left/right
- ENTER (E) – enter command for selected menu, character or prompt acknowledge
- RPT (F) – repeat last voice instruction
- NAV (G) – activate navigation system

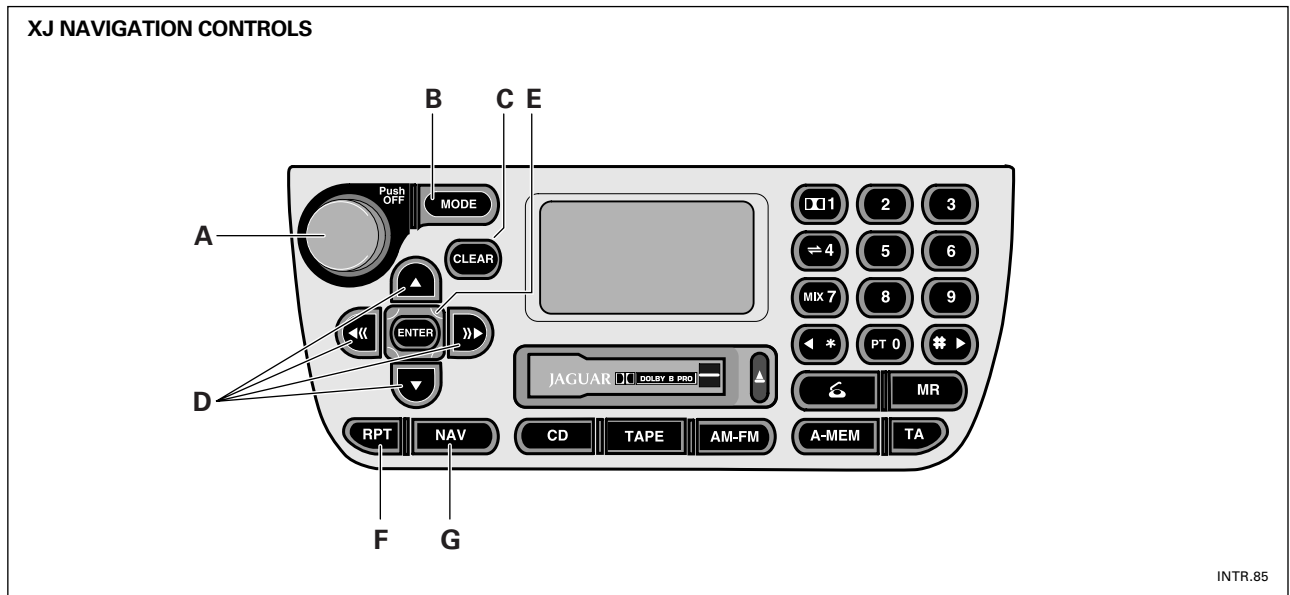

NOTES

XK Navigation Display and Controls Panel

The drivers navigation display and controls are provided by a single integral panel which is non-serviceable. The panel fits into the central fascia otherwise occupied by the clock, oil pressure and battery condition instruments: oil pressure and battery condition are indicated by icons on the main instrument cluster. The panel is fixed by four screws, accessible from the front, and is finished by a new clip in veneer panel with cut-outs.

All navigation information is shown in full color on the large display screen. The navigation controls are located on both sides of the screen and are as follows:

- Main MENU (A) – display choice of Destination, Set-up, Options, Route
- LIST (B) – list turn information for calculated route
- CLEAR (C) – return to previous screen or change map orientation
- Joystick/enter (D) – highlight menu items, characters and scrolls map: enter commands and selections
- ON/OFF (E) – turn screen on or off
- MAP (F) – switch to, or return from map display and toggle map/arrow view when under guidance
- REPEAT (G) – repeat last voice instruction
- SCALE (H) – change map scale and scrolls previous or next page

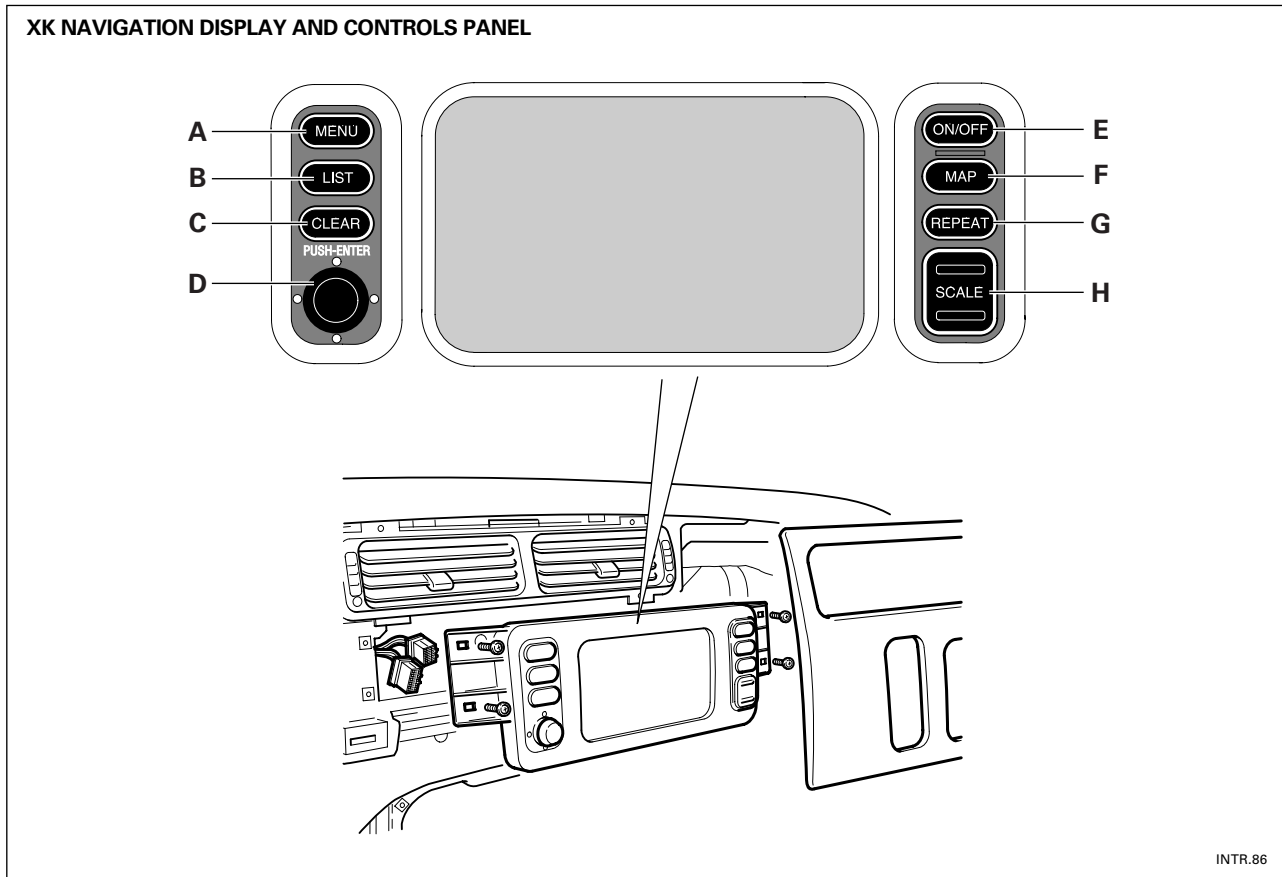

BODY SYSTEMS

Navigation System (continued)

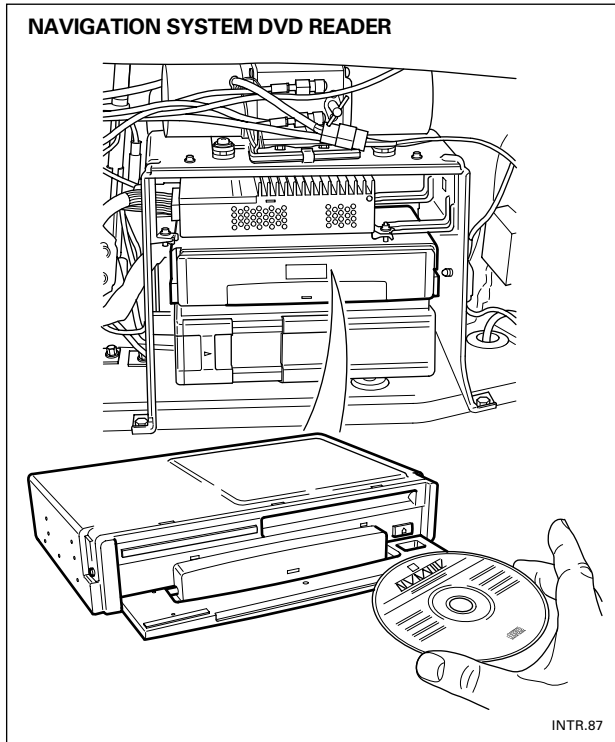

Navigation System DVD Reader

The navigation system DVD reader is mounted between the CD changer and optional power amplifier on a modified bracket in the trunk. The DVD reader provides data storage, processing and system control and incorporates a gyrometer to measure yaw rate. The unit also receives and processes satellite information from the GPS antenna to determine the absolute position of the vehicle.

The navigation system DVD reader incorporates a digital versatile disc (DVD) drive to provide the interchangeable map data. The DVD represents the latest technology, providing approximately eight times more data on a single disc than a standard CD-ROM. This amount of data storage is an advantage in reducing the number of discs required to cover the current navigable countries: USA (1 disc), Europe (5 discs), Japan (1 disc, XJ only).

There are no controls on the DVD reader. To load the unit, the front panel is pulled down (bottom hinge) and the disc is inserted directly into the slot. Before loading a disc, always press the eject button to check if a disc is already present so as to avoid possible damage.

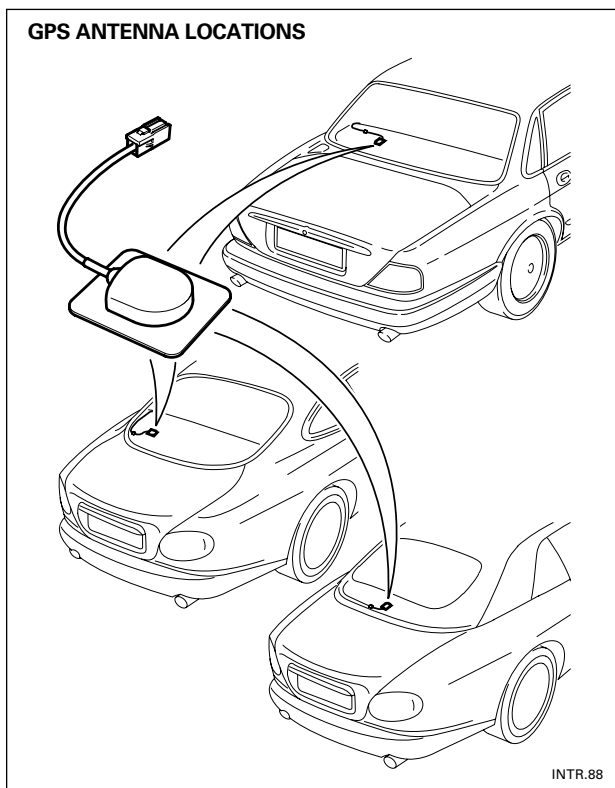

GPS Antenna

The satellite global positioning (GPS) antenna is common to all models and is mounted on the rear trim shelf, as shown, to obtain best reception. The antenna output signals are connected by a co-axial cable to the navigation system DVD reader. Since the antenna module contains active receiver circuits, the inner co-axial conductor also carries a 5V dc power supply from the DVD reader.

The antenna is fixed to the rear trim shelf via a self adhesive coating on the antenna mounting plate.

Signal reception may be affected by the presence of metal objects or foil on or near the rear shelf or rear screen.

NOTES

Vehicle Speed Interface Module

One type of data required by the navigation system is the current vehicle road speed. The ABS/traction control module calculates the vehicle speed from wheel speed sensor inputs and broadcasts the speed over the CAN data bus. To access this data, the new navigation system vehicle speed interface module is connected to the CAN bus and sends a signal with a frequency proportional to vehicle speed to navigation system DVD reader.

The navigation vehicle speed interface module is an integral electronic unit common to both XJ and XK vehicles. On XJ vehicles, the module is fitted with a bracket which is fixed to two threaded studs on the underside of the coolbox mounting plate. The bracket has fixing slots, enabling the module to be removed or fitted without fully unscrewing the securing nuts. On XK vehicles, the module is fixed by Velcro to the underside of the engine bay coolbox cover.

NOTES

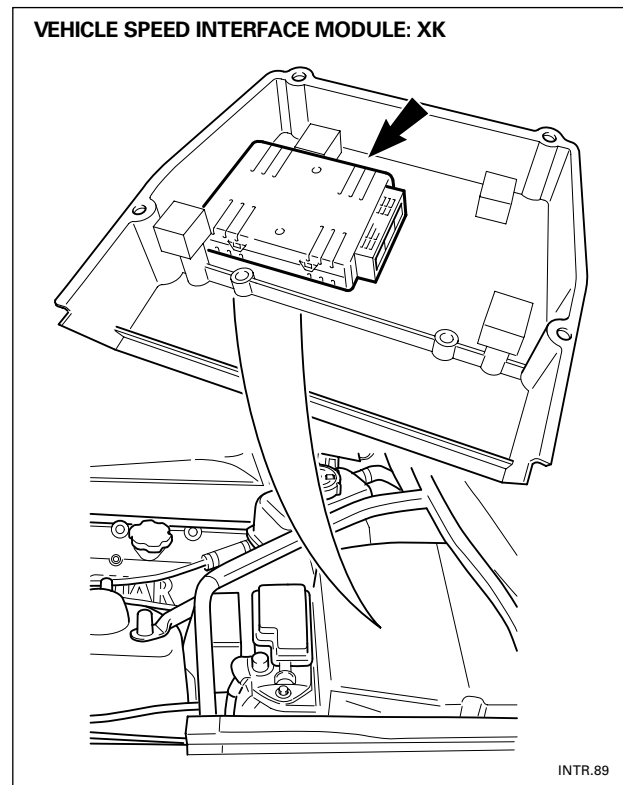
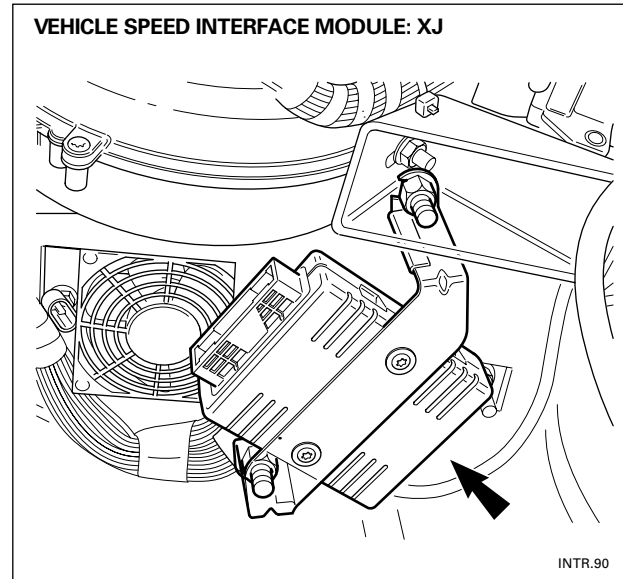

INTRODUCTION TO JAGUAR

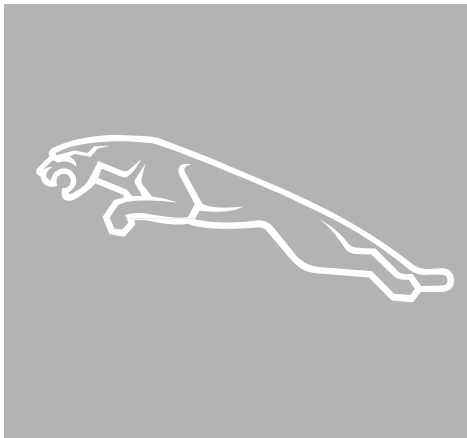

1 INTRODUCTION TO XJ/XK

- 1.1 Overview
- 1.2 Engine
- 1.3 Engine Management
- 1.4 Transmissions
- 1.5 Suspension, Steering and Brakes
- 1.6 Climate Control
- 1.7 Electrical Distribution System
- 1.8 Body Systems

1.9 Occupant Protection

- 1.10 Task Sheets



OCCUPANT PROTECTION: XJ

XJ vehicles comply with the occupant protection and safety standards of all countries. Body torsional rigidity and side impact resistance is improved through the revision of some body components and the use of high strength steel in a number of body panels.

Three-point active seat belts with pyrotechnic pretensioning retractors are fitted to the driver and front passenger positions. Pyrotechnic front airbags for the driver and passenger deploy to additionally protect the occupants during frontal impacts. Argon gas inflated side airbags located in the outboard frames of the driver and front passenger seats deploy to protect the occupants in the event of a severe side impact. A single-point sensing module (SPS) controls the operation of the front airbags and the front seat belt pretensioners. Side airbag deployment is controlled by the SPS using input signals from separate side impact sensors.

Active three-point seat belts are provided for the rear seat passengers.

WARNING: READ AND OBSERVE ALL SAFETY PRECAUTIONS IN JTIS (JAGUAR TECHNICAL INFORMATION SYSTEM) AND SERVICE BULLETINS BEFORE ATTEMPTING TO SERVICE THE FRONT OR SIDE AIRBAGS, THE STEERING WHEEL, THE AREA AROUND THE PASSENGER AIRBAG, THE FRONT SEAT BELT PRETENSIONING RETRACTORS, THE FRONT SEATS, OR ANY AIRBAG / SRS COMPONENTS.

OBSERVE ALL SAFETY PRECAUTIONS WHEN HANDLING OR TRANSPORTING AIRBAG MODULES.

DO NOT ATTEMPT TO MEASURE CIRCUIT RESISTANCE THROUGH THE AIRBAG MODULES OR THE SEAT BELT PRETENSIONING RETRACTOR UNITS. DOING SO MAY TRIGGER DEPLOYMENT AND RESULT IN PERSONAL INJURY.

DO NOT ATTEMPT TO REPLACE THE AIRBAG / SRS BATTERY POWER FUSE UNLESS THE SYSTEM IS DISARMED.

TO DISARM THE SRS SYSTEM, DISCONNECT THE NEGATIVE BATTERY CABLE AND WAIT A MINIMUM OF ONE MINUTE FOR THE RESERVE POWER CHARGE TO DISSIPATE.

NOTES

Electronic Single-Point Sensor Airbag / SRS

System Description

The SPS (electronic single-point sensor) Airbag / SRS system is a microprocessor controlled system that controls the deployment of the driver and passenger front and side airbags, and the front seat belt pretensioning retractors. The system connects to: the data link connector (DLC) for WDS diagnosis, the instrument pack for the AIRBAG / SRS MIL, and the body processor module (BPM) for an audible backup warning in case of MIL failure. The SPS Airbag / SRS system is not part of the vehicle multiplex circuitry.

A 5 A, fused, ignition switched B+ circuit provides system power.

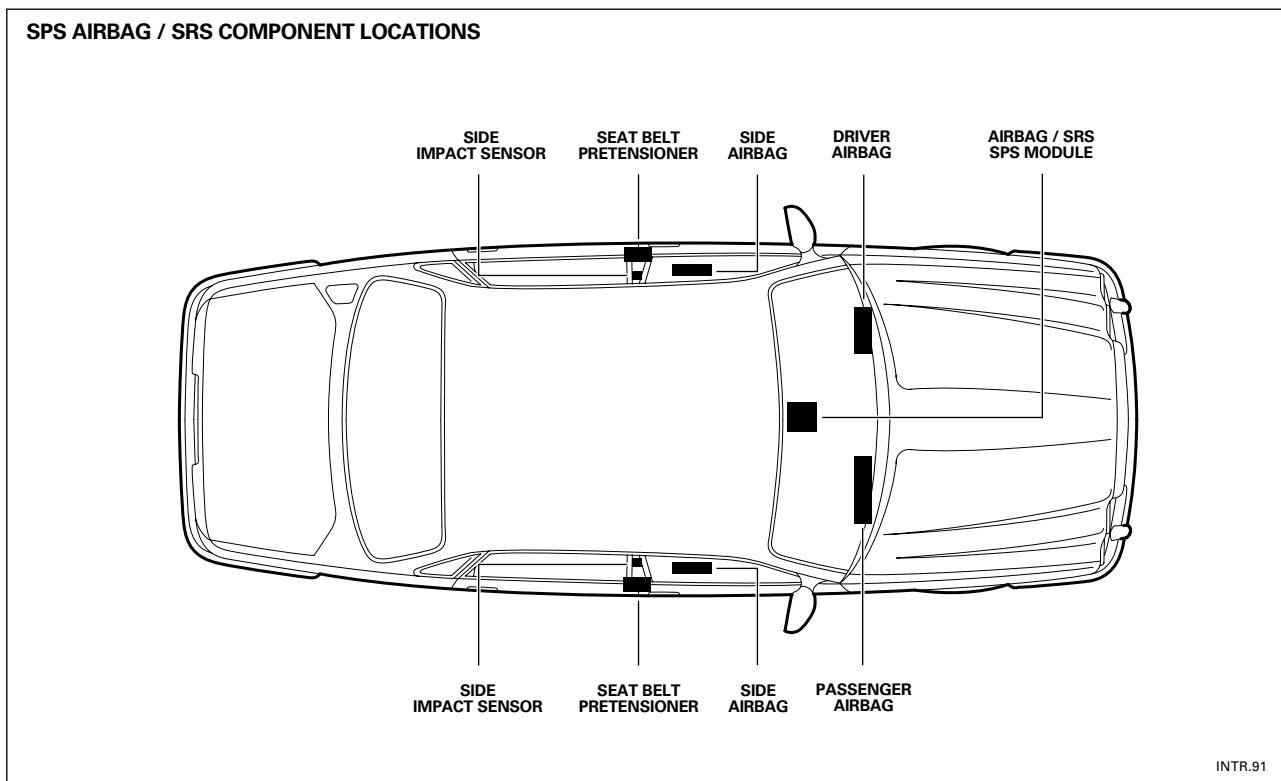

NOTES

OCCUPANT PROTECTION: XJ

Electronic Single-Point Sensor Airbag / SRS (continued)

System Description

Frontal impact

If the impact sensor in the SPS module detects a frontal impact above a certain threshold and the impact is also detected by the safing sensor in the SPS module, the module fires both front seat belt pretensioners and both front airbags. The side airbags are not fired during frontal impacts.

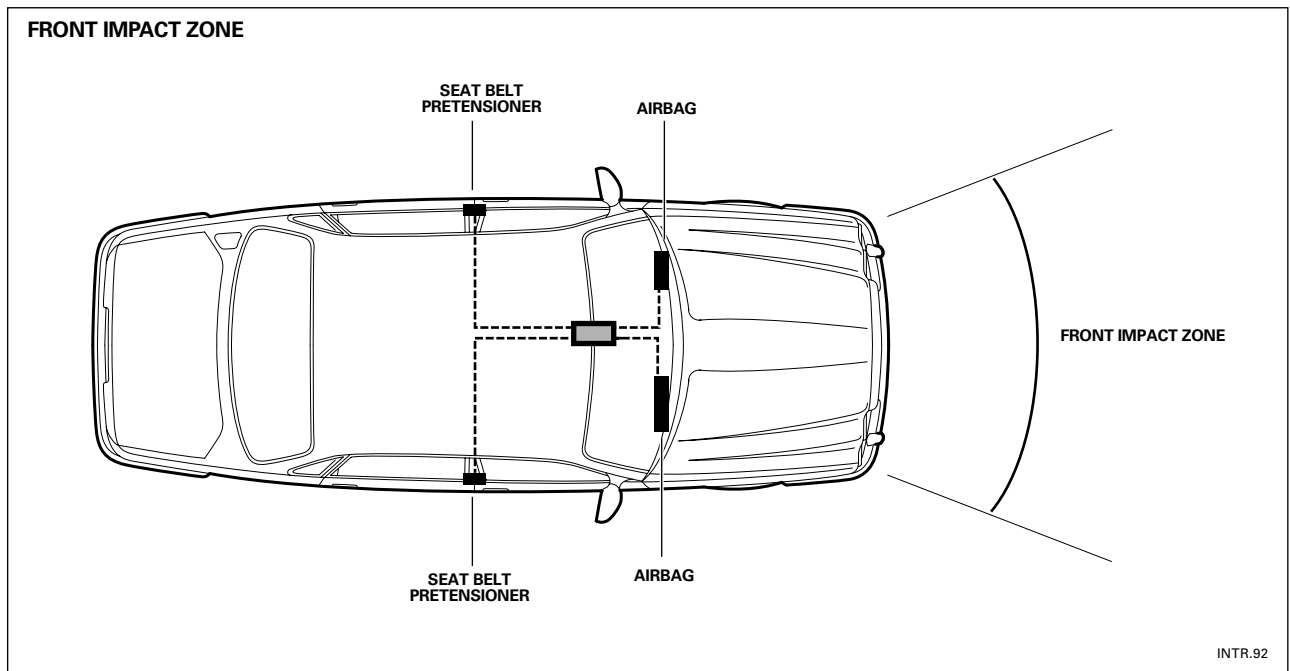

NOTES

Side impact

If a side impact sensor in the B/C post detects a side impact above a certain threshold and the impact is also detected by the side impact safing sensor in the SPS module, the module fires the side airbag on the impacted side of the vehicle. The front airbags, seat belt pretensioners, and the airbag on the other side of the vehicle are not fired.

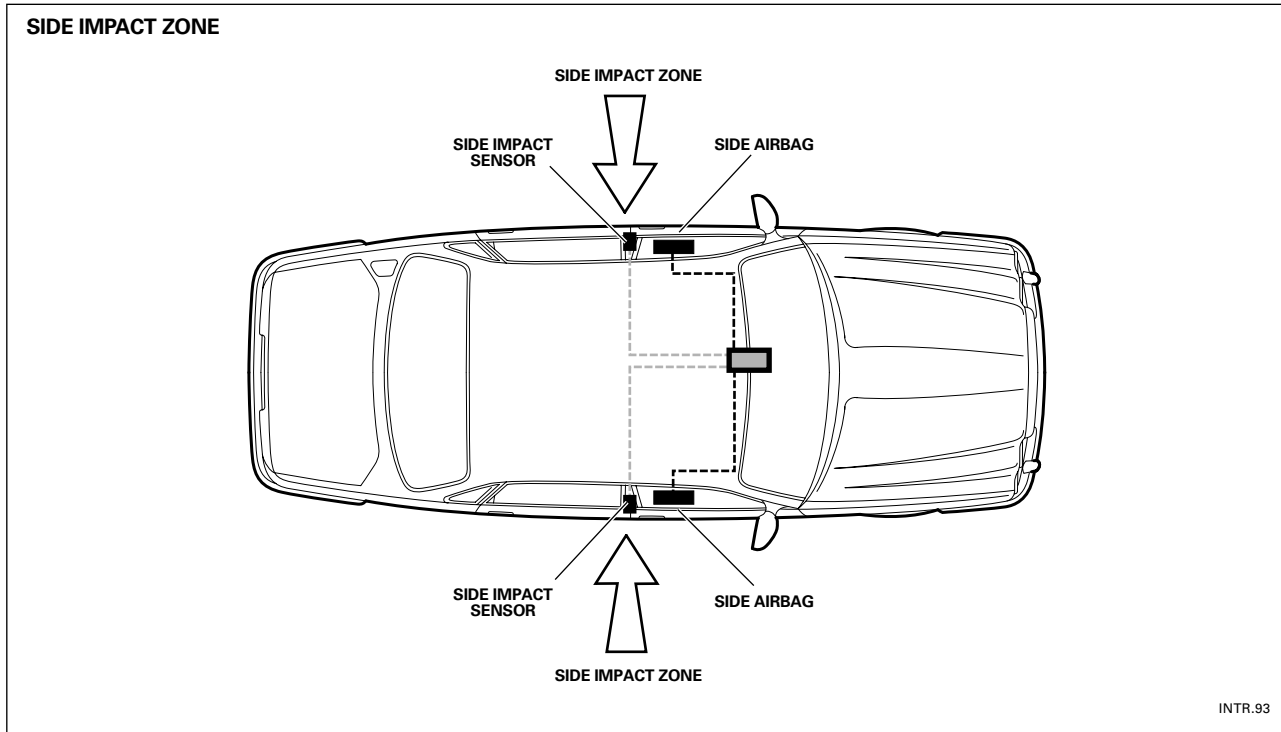

Single Point Sensor

The SPS performs the functions that, in the previous system, were performed by the front impact sensors, the safing sensor and the airbag/SRS control module. In addition, it controls the operation of the front seat belt pre-tensioners and the side airbags. The SPS is installed on the driveshaft tunnel directly below the radio.

Contained in the SPS are:

- an electronic front impact sensor
- a sleeve-on-shaft front impact safing sensor
- an electronic side impact safing sensor
- related operating and diagnostic circuitry

An integral back-up power supply enables the SPS to operate the system if the external supply is disrupted during an impact.

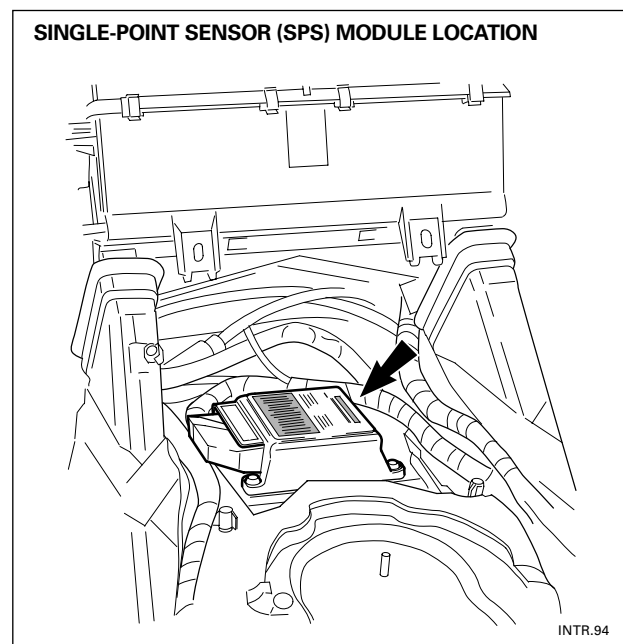

OCCUPANT PROTECTION: XJ

Electronic Single-Point Sensor Airbag / SRS (continued)

Airbags

Passenger Airbag Module

The passenger airbag module uses a tethered deployment door similar to XK. The deployment door retaining clips must be replaced every time the door is removed.

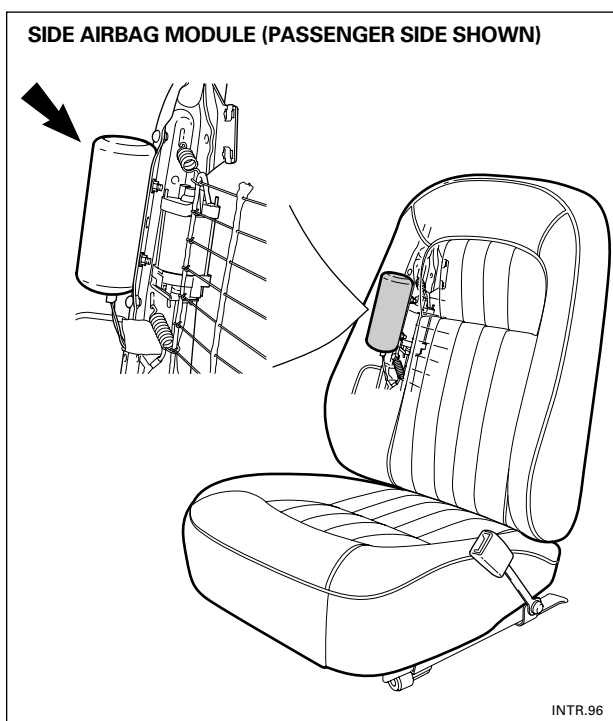
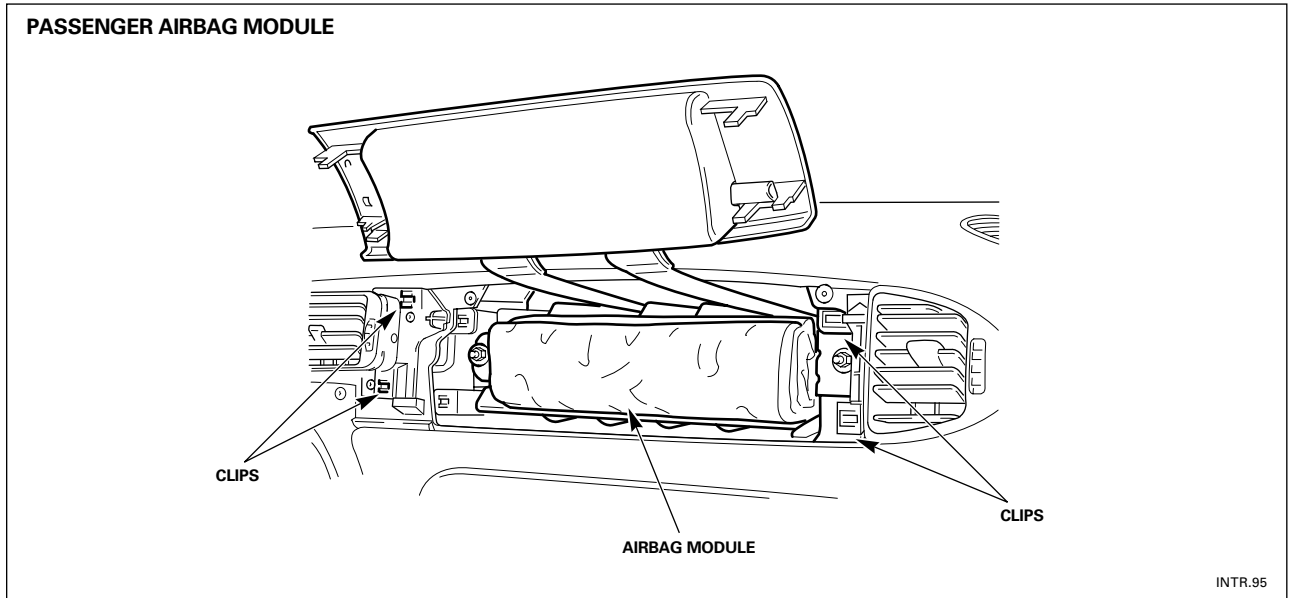

Side Airbags

A side airbag module is attached to the outboard side of each front seat back frame. The module is contained in a cavity formed in the outboard seat bolster padding. A slit in the padding directs the expanding bag to deploy through the existing side bolster stitched seam. The airbag fully deploys within 11 milliseconds of impact.

If a side impact causes airbag deployment, the seat should be replaced because the impact would be severe enough to cause structural damage to the seat and the vehicle.

WARNING: AFTERMARKET SEAT COVERS MUST NOT BE INSTALLED ON SIDE AIRBAG EQUIPPED SEATS BECAUSE THEY MAY INTERFERE WITH AIRBAG DEPLOYMENT.

LOOSE ITEMS SHOULD NOT BE CARRIED IN THE SEATS WHERE THEY COULD INJURE VEHICLE OCCUPANTS IN THE EVENT OF SIDE AIRBAG DEPLOYMENT.

Front Seat Belt Pretensioners

The front seat belt pretensioners are located in the B/C posts. In the event of front airbag deployment, the pretensioners activate to remove seat belt slack. The seat belt pretensioning retractor units are pyrotechnic devices similar to the XK8 units, except that they are triggered together electronically by the Airbag / SRS system when the front airbags are deployed. Refer to Pretensioning retractor units on page 10 of the XK8 section.

Pre-tensioner Assembly

The pre-tensioner assembly is a compact, self contained unit mounted to a body bracket by a single bolt and anti-rotational fixing. The assembly is not serviceable and must be replaced if the pyrotechnic is discharged. While the pre-tensioner assembly is intrinsically safer than the mechanically triggered type, the normal safeguards and procedures applicable to the storage, handling and disposal of pyrotechnic devices must be followed.

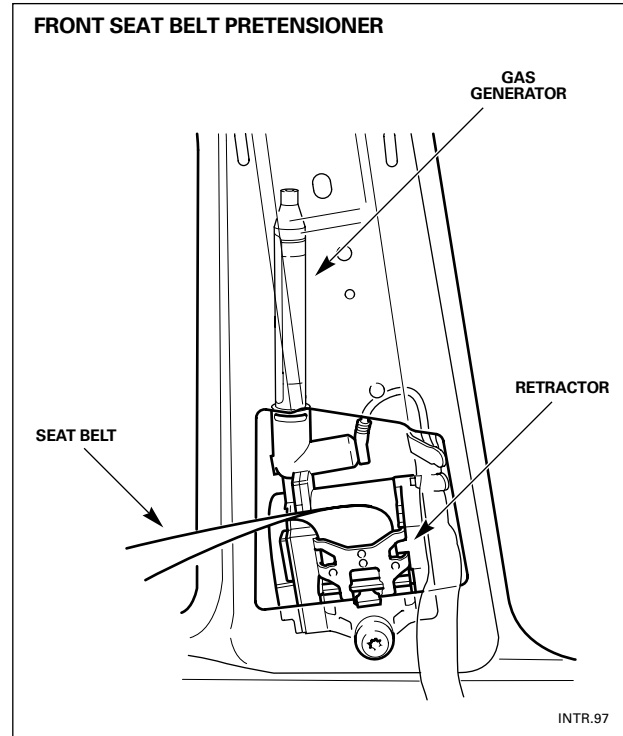

NOTES

OCCUPANT PROTECTION: XK

Jaguar XK vehicles comply with the occupant protection and safety standards of all countries. From 1997 – 2002 MY, the XK has had three occupant protection variants.

WARNING: READ THE INSTRUCTIONS IN THE SERVICE MANUAL AND OBSERVE ALL SAFETY PRECAUTIONS BEFORE ATTEMPTING TO SERVICE THE STEERING WHEEL, THE AREA AROUND THE PASSENGER AIRBAG, OR ANY AIRBAG / SRS COMPONENTS. OBSERVE ALL SAFETY PRECAUTIONS WHEN HANDLING OR TRANSPORTING AIRBAG MODULES.

DO NOT ATTEMPT TO MEASURE CIRCUIT RESISTANCE THROUGH THE AIRBAG MODULES. DOING SO MAY TRIGGER AIRBAG DEPLOYMENT AND RESULT IN PERSONAL INJURY.

DO NOT ATTEMPT TO REPLACE THE AIRBAG / SRS 10 A BATTERY POWER FUSE UNLESS THE SYSTEM IS DISARMED (1997 – 2000 MY).

TO DISARM THE SRS SYSTEM, DISCONNECT THE NEGATIVE BATTERY CABLE AND WAIT A MINIMUM OF TWO MINUTES FOR THE RESERVE POWER CHARGE TO DISSIPATE.

1997 – 1999 MY

Active three-point seat belts are fitted for the driver and passenger positions. An electromechanical airbag is mounted in the steering wheel for the driver and in the fascia for the front passenger. In addition, the front seat belt retractors include pyrotechnic seat belt pretensioners. Rear seat passenger positions are equipped with conventional three-point seat belts.

NOTES

Airbag Deployment

In the event of an impact severe enough to trigger at least one impact sensor plus the safing sensor, both airbags are triggered and deploy within 32 milliseconds. The impact force will also independently trigger the mechanically sensed pretensioning retractors of buckled front seat belts. The pretensioning retractors position the belts to optimum tension and lock their retractor mechanisms.

Airbag Modules

Non-serviceable modules are provided for the front seat occupants. Each module consists of an inflator assembly, airbag, and trim. When electrically ignited by the system, the inflation charge generates a volume of nitrogen gas to inflate the bag. The force of the inflation displaces the trim and the airbag deploys in the passenger compartment.

The driver side module is located in the center of the steering wheel; the passenger side module is located in the fascia. The passenger side deployment door snaps onto the fascia. Straps attach to the airbag module mounting bracket to control the door during deployment.

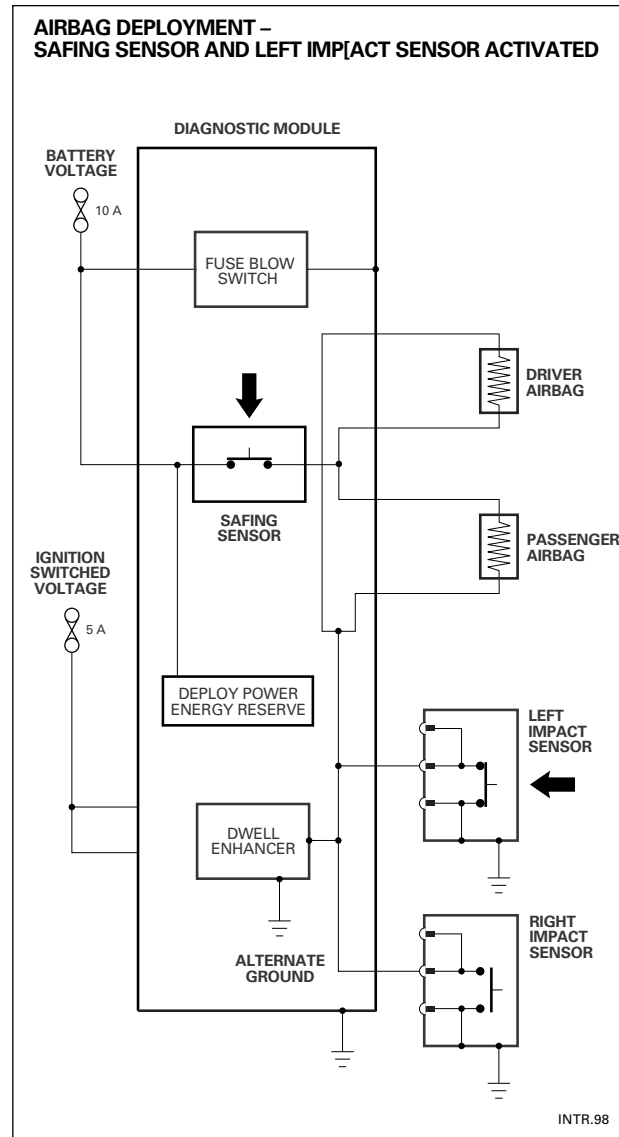
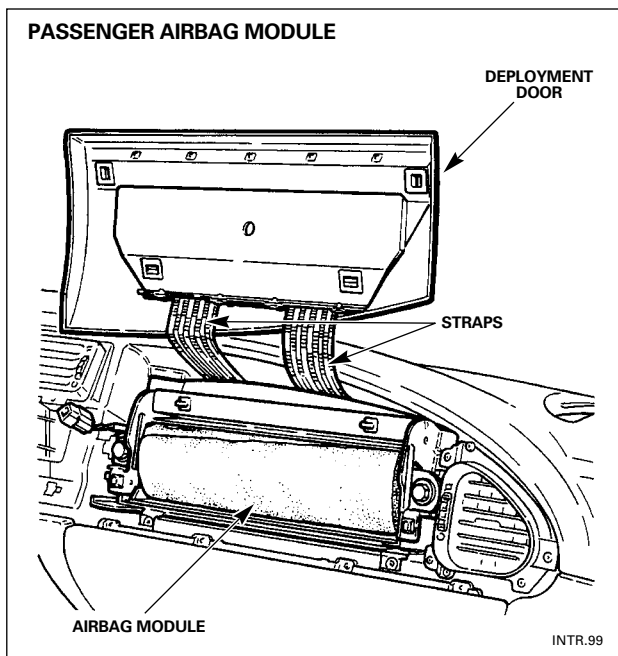

OCCUPANT PROTECTION: XK

1997 – 1999 MY (continued)

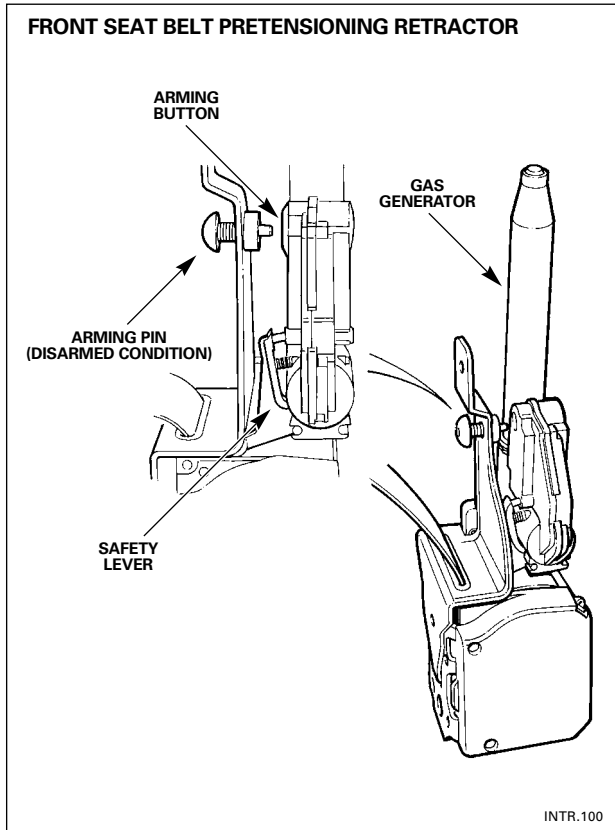

Pretensioning retractor units

The front seat belt pretensioners are pyrotechnic devices that remove seat belt slack and lock the retractors in the event of a severe frontal impact. Tear-loop-type seat belts are not used on XK8 vehicles.

Each self-contained pretensioning retractor unit consists of a mechanical impact sensor and triggering control, a gas generator, and a piston / cable assembly that connects to the seat belt retractor mechanism. If a frontal impact of sufficient force occurs within 30° of the vehicle center line and the seat belt is in use, the pretensioner activates. The impact sensor ignites a solid nitrocellulose propellant in the gas generator, driving the piston / cable assembly connected to the retractor mechanism. The cable turns the retractor to remove excess seat belt slack at the moment of airbag / SRS deployment. After activation, the seat belt is locked. It will not retract and cannot be pulled from the retractor reel. The retractor unit / seat belt assembly must be replaced following activation.

Pretensioning retractor arming

The pretensioning retractor unit is armed at installation by screwing in the red arming pin to fully depress the red arming button. Once installed, a safety lever prevents the impact sensor from activating the pretensioner with the seat belt fully retracted. When the seat belt is pulled from the retractor reel (seat belt in use by an occupant or securing a child seat), the safety lever moves and the unit is ready to activate if an impact occurs.

WARNING: IF A PRETENSIONING UNIT IS RUPTURED AND PROPELLANT INGESTION OR INHALATION OCCURS, APPLY FIRST AID AND SEEK MEDICAL ADVICE.

DO NOT ATTEMPT TO DISMANTLE THE NON-SERVICEABLE RETRACTOR UNIT.

WHEN HANDLING THE RETRACTOR UNIT, THE PISTON MUST ALWAYS BE POINTED DOWN AND AWAY FROM ANYONE. KEEP FINGERS AWAY FROM THE RETRACTOR REEL MECHANISM.

IF A PRETENSIONING RETRACTOR UNIT IS DROPPED FROM A HEIGHT GREATER THAN 0.3 M (12 IN.), IT MUST NOT BE FITTED TO A VEHICLE.

NOTES

2000 MY

Electrical Seat belt Pretensioners

While the electro/mechanical airbag system remained unchanged from the 1997 – 1999 MY XK, the previously fitted mechanical/pyrotechnic front seat belt pretensioners are replaced with electrical/mechanical pretensioners. The pretensioners are fire by electrical signals from an impact sensing/control module mounted on the transmission tunnel and the system operates completely independently of the airbag system.

Pre-tensioner Assembly

The pre-tensioner assembly is a compact, self contained unit mounted to a body bracket by a single bolt and anti-rotational fixing. The assembly is not serviceable and must be replaced if the pyrotechnic is discharged. While the pre-tensioner assembly is intrinsically safer than the mechanically triggered type, the normal safeguards and procedures applicable to the storage, handling and disposal of pyrotechnic devices must be followed.

NOTES

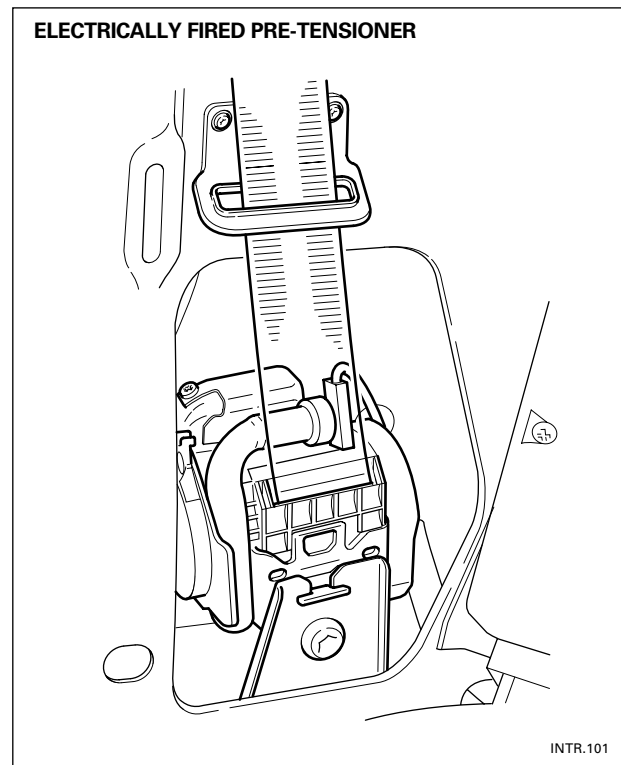

OCCUPANT PROTECTION: XK

2001 – 2002 MY

Advanced Restraints System

New technologies have permitted the development of an 'Advanced Restraints System' that provides an improved overall level of frontal crash protection for the front seat occupants. The system analyzes the occupancy scenario and crash severity before activating the appropriate safety devices to help better protect a range of occupants in a variety of frontal crash situations.

Benefits of the new system include:

- Optimization of the deployment restraint devices.
- The reduction in potential for airbag induced injuries.
- The significant reduction in passenger airbag deployments (particularly when passenger seats are unoccupied) and a general reduction in all airbag deployments.

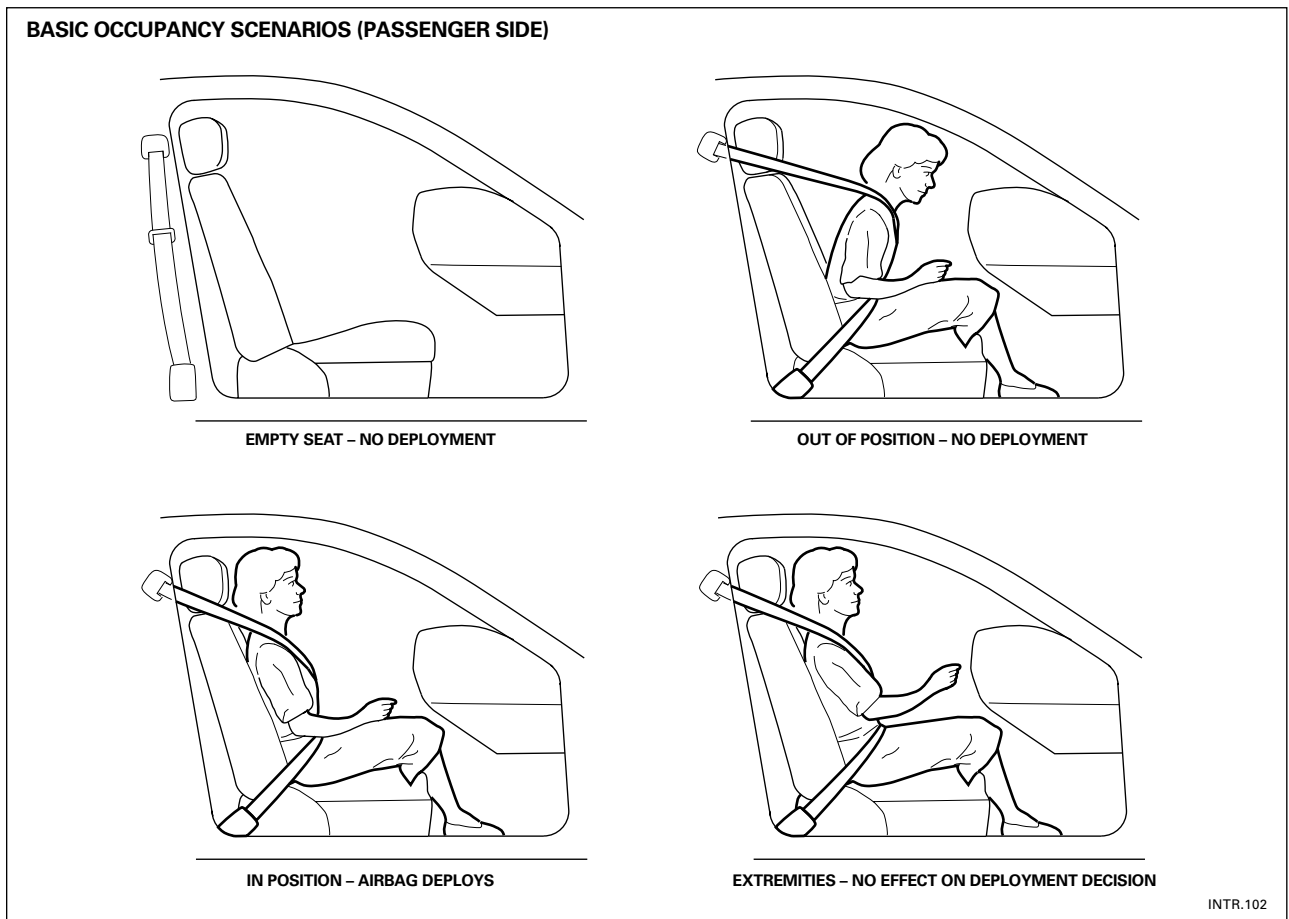

NOTES

In order to support the advanced restraint system requirements, a new restraint control architecture has been introduced comprising the following systems or components;

- Passenger occupancy sensing system.
- All-electronic crash sensing including frontal crash severity sensing and advanced restraints management.
- Driver airbag with twin stage inflator.
- Passenger airbag with twin stage inflator.
- Child seat lower ISO fix anchors for rear seats.
- Safety belt system including front belt use detection, load limiting and electrical comfort system.
- Front seats including driver seat track position sensor and passenger seat weight-sensing system.
- Lower steering column.
- Front seat mounted, side airbags.

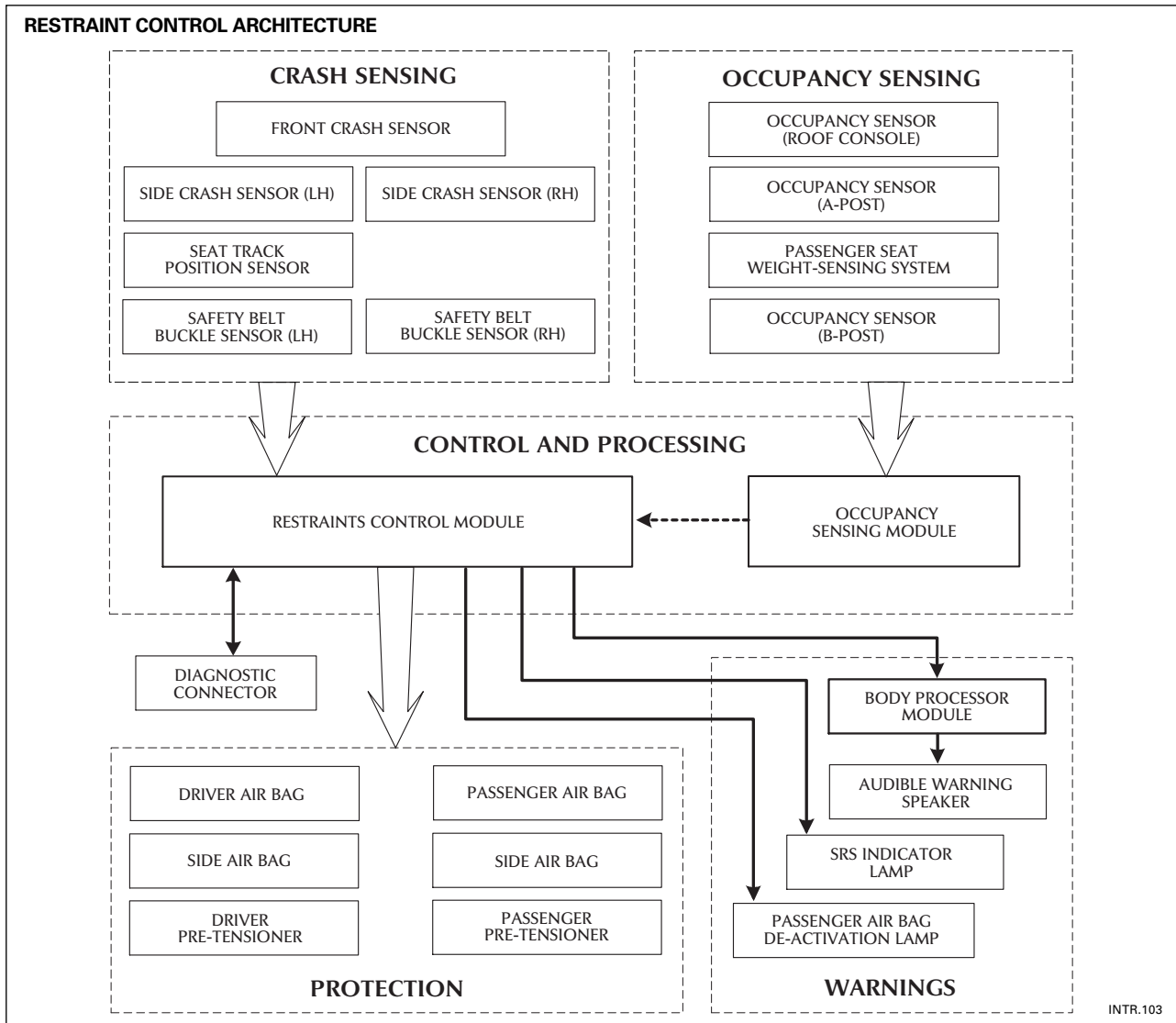

INTR.103

OCCUPANT PROTECTION: XK

2001 – 2002 MY (continued)

Airbag Modules

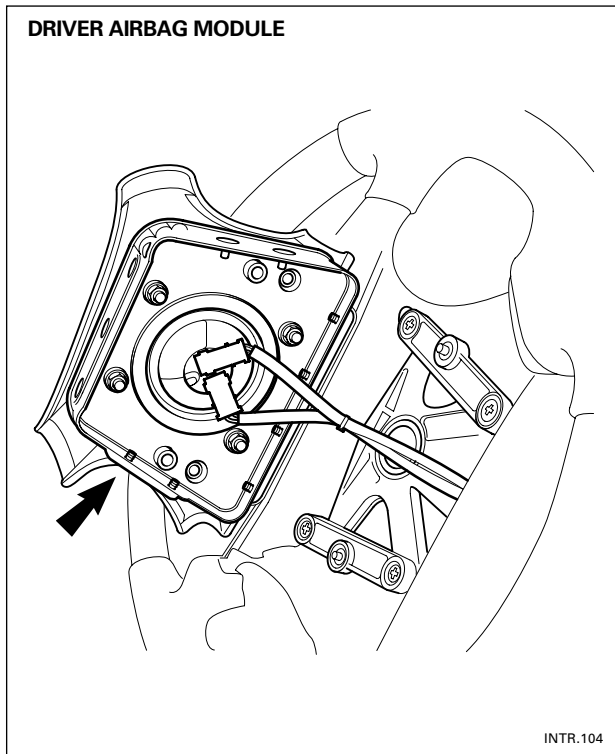

Driver Airbag Module

The driver airbag module is controlled by the restraints control module (RCM), which chooses between first or second stage deployment depending on occupant position and crash severity.

NOTE: Variation in passenger airbag deployment is determined by the timing of the first and second stage ignition signals. This facilitates adaptation of the stiffness and timing of the airbag to optimize occupant protection.

The module comprises:

- A twin stage inflator as opposed to the single stage inflator.
- Separate chambers for the two inflation stages, each independently activated by the RCM.
- Two airbag squib connectors, that have foolproof mechanical keying and are color coded to the respective plug on the inflator.
- A non-azide propellant that reduces particulates and effluents.

The airbag deploys radially, to reduce the risk of airbag induced injury to a driver that is positioned close to the steering wheel.

NOTES

Side Airbag Module

The side airbag module is a new feature for XK vehicles, designed to provide protection for the thorax (the part of the trunk between the neck and abdomen) and head.

The module:

- is mounted in the outboard bolster of each front seat;
- is standard fit and specification in all markets;
- does not require routine maintenance;
- has no serviceable parts;
- uses compressed argon to inflate the bag.

NOTE: As with all occupant safety components, the SRS indicator lamp will illuminate if a DTC has been stored. Diagnosis must be undertaken using WDS.

In an airbag deployment situation, the airbag deploys through the stitch seam in the side bolster. To ensure the airbag always emerges at the same point, a chute is attached to the inside of the trim cover and wrapped around the airbag module.

WARNING: IN A SERVICE SITUATION, THE MODULE MUST BE CORRECTLY LOCATED IN THE CHUTE. FAILURE TO FOLLOW THE SERVICE PROCEDURE COULD RESULT IN INCORRECT AIRBAG DEPLOYMENT; REFER TO JTIS.

NOTE: In the event of a side impact that is sufficient to deploy the bag, it will be necessary to replace the complete seat.

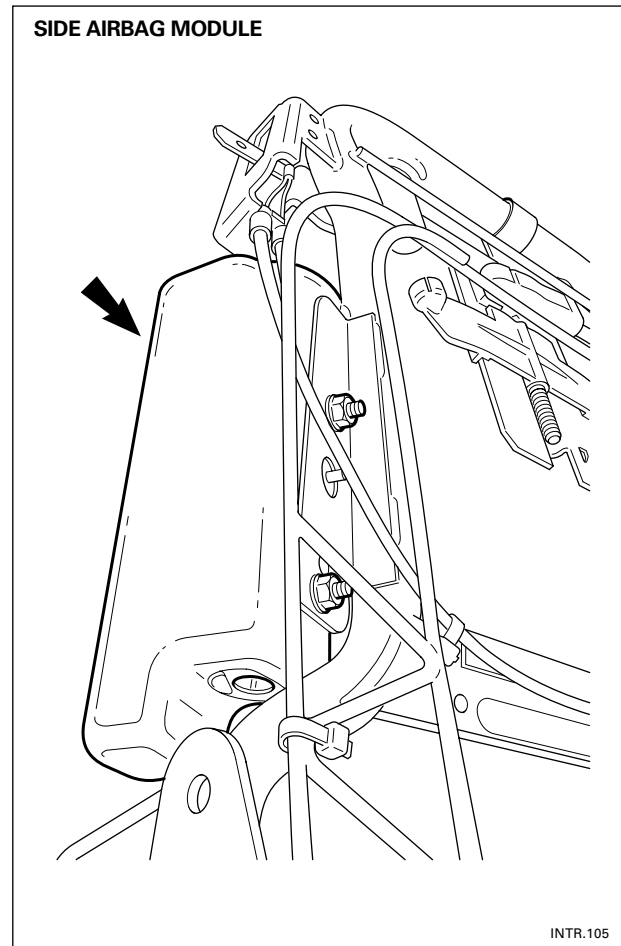

INTR.105

NOTES

OCCUPANT PROTECTION: XK

2001 – 2002 MY (continued)

Airbag Modules

Passenger Airbag Module

The passenger airbag module is controlled by the restraints control module (RCM), which chooses between first or second stage deployment, depending on occupant status and crash severity.

NOTE: Variation in passenger airbag deployment is determined by the timing of the first and second stage ignition signals. This facilitates adaptation of the stiffness and timing of the airbag to optimize occupant protection.

The module comprises:

- A twin stage inflator as opposed to the single stage inflator.
- Two airbag squib connectors to accommodate the twin stage inflation.

The inflator is a development of the heated gas inflator technology developed for the S-TYPE sports saloon, which replaces the conventional pyrotechnic device, previously used for the XK Range of vehicles.

The heated gas inflator:

- Comprises a high-pressure mix of clean air and hydrogen gas, triggered by two separate ignition squibs.
- Produces a controlled generation of clean gas to rapidly fill the airbag.
- Is classified as a stored flammable gas (not as an explosive) and as such, has less restrictive storage and transportation requirements.
- Produces a very clean burn and almost no particulates.
- Is almost free of any toxins, making disposal or recycling much easier.

NOTE: Disposal of twin stage airbags is different from single stage airbags; refer to JTIS.

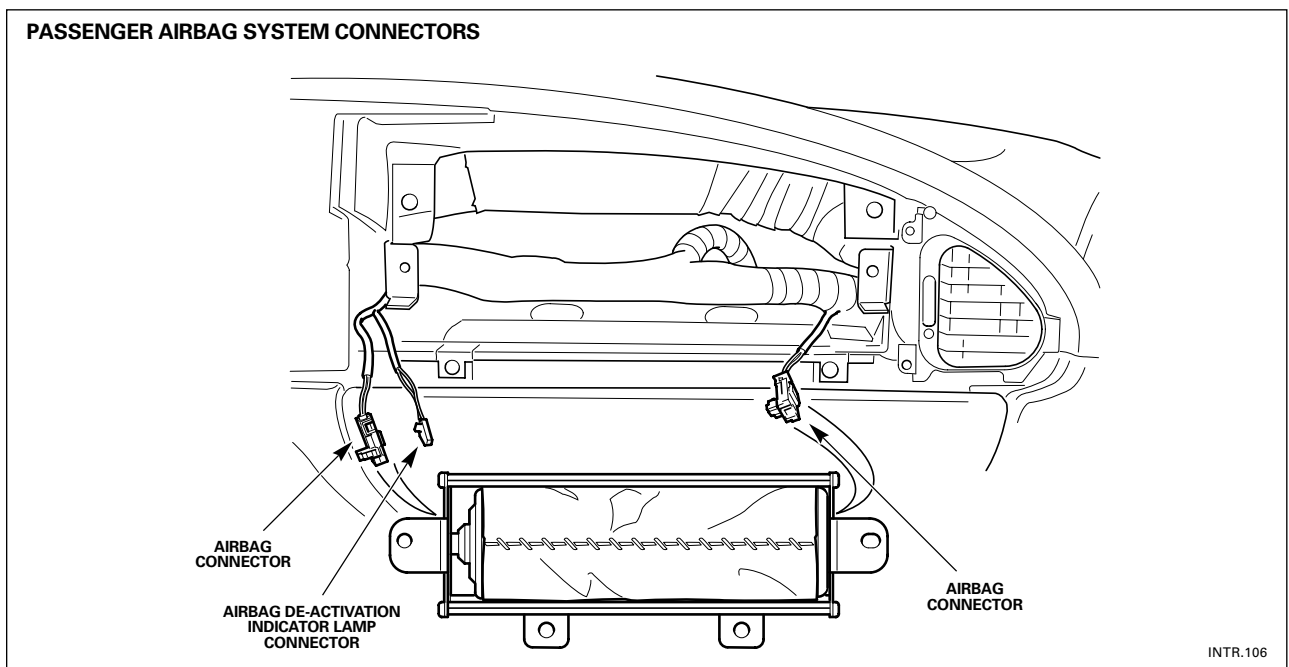

INTRODUCTION TO JAGUAR



1 INTRODUCTION TO XJ/XK

2 INTRODUCTION TO S-TYPE

2.1 Overview

2.2 Engine

2.3 PTEC Engine Management

2.4 Transmission

2.5 Suspension, Steering and Brakes

2.6 DATC Climate Control

2.7 Electrical Distribution System

2.8 Body Systems

2.9 Occupant Protection

2.10 Task Sheets



OVERVIEW

General Information

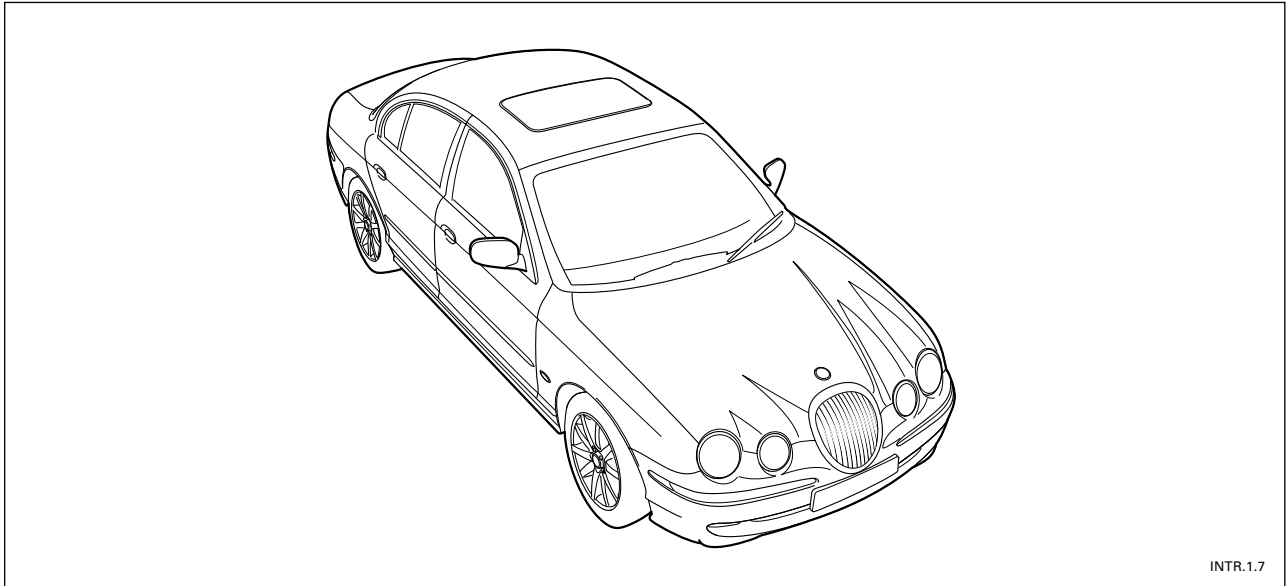

The Jaguar S-TYPE is a luxury sports sedan with a distinctive style, refined power, agile handling, supple ride and luxurious comfort.

Powertrains are a V8 (AJ28) engine, derived from the engines currently used in XJ/XK vehicles, and a V6 (AJ-V6) engine. Both engines are coupled to a new five-speed automatic transmission. The new V6 and updated V8 engines and the transmission unit are described in the 'Jaguar S-TYPE Powertrain Introduction' Technical Guide.

As with current vehicles, variable rate steering control is fitted and all vehicles have ABS brakes with traction control as standard. A new, optional feature with the Jaguar S-TYPE is Dynamic Stability Control (DSC), yaw control, which assists the driver in maintaining directional control of the vehicle. Unlike current vehicles, the hood is hinged at its rear with a safety catch provided at the front of the hood. A tilt and slide sliding roof with sunshade is an optional feature.

Both front seats have electrically operated 8-way adjustments as standard and memory equipment is available as an option. To allow a greater load to be carried in the luggage compartment, the rear seats can be folded forwards and are split in a 60/40 configuration.

Automatic climate control, with dual temperature control for the driver and front passenger, is a standard feature on all vehicles. Another new item is reverse park control, a system giving the driver audible warning of obstructions which could damage the vehicle during reversing.

A standard fit radio/cassette unit provides in-car entertainment with a CD autochanger also being offered. Other options include a phone, navigation system, vehicle emergency monitoring system and certain voice activated systems. Optional cruise control and audio switches are fitted to the steering wheel. All vehicles have a trip computer system and a message center.

Security features are immobilizer and alarm. A 4-button key-ring transmitter has a radio frequency operation with an encrypted rolling code to help prevent theft of the vehicle.

Standard Corporate Protocol (SCP) is the only network for all the vehicle electronic controls, CAN is not used.

Vehicle Weights

	Kerb Weight (approximate)			Gross Vehicle Weight (approximate)		
	Front Axle	Rear Axle	Total	Front Axle	Rear Axle	Total
Vehicles with 3.0L V6 engine	850 kg (1874 lb.)	785 kg (1730 lb.)	1635 kg (3604 lb.)	998 kg (2200 lb.)	1177 kg (2595 lb.)	2175 kg (4795 lb.)
Vehicles with 4.0L V8 engine	915 kg (2017 lb.)	810 kg (1786 lb.)	1725 kg (3803 lb.)	1018 kg (2244 lb.)	1177 kg (2595 lb.)	2195 kg (4839 lb.)

Dimensions

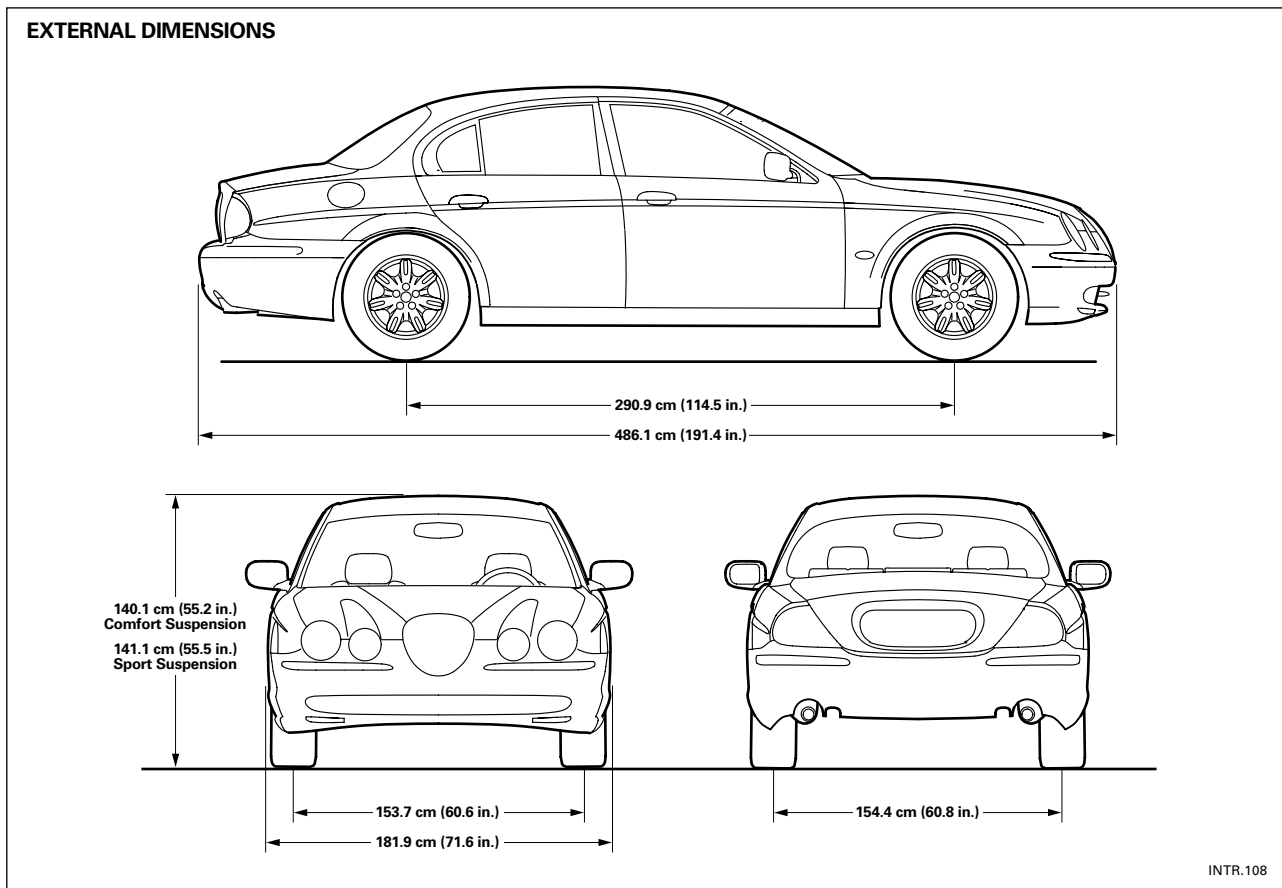

NOTES

OVERVIEW

Vehicle Identification Numbers (VIN)

Identification Plates and Labels

The Vehicle Identification Number (VIN) is displayed, from outside the vehicle, on a plate visible in the lower left edge of the windshield. There is also a certification label attached to the LH front door hinge pillar which gives details of vehicle weights, paint code, trim, date of manufacture and VIN.

IDENTIFICATION PLATE AND LABEL LOCATION

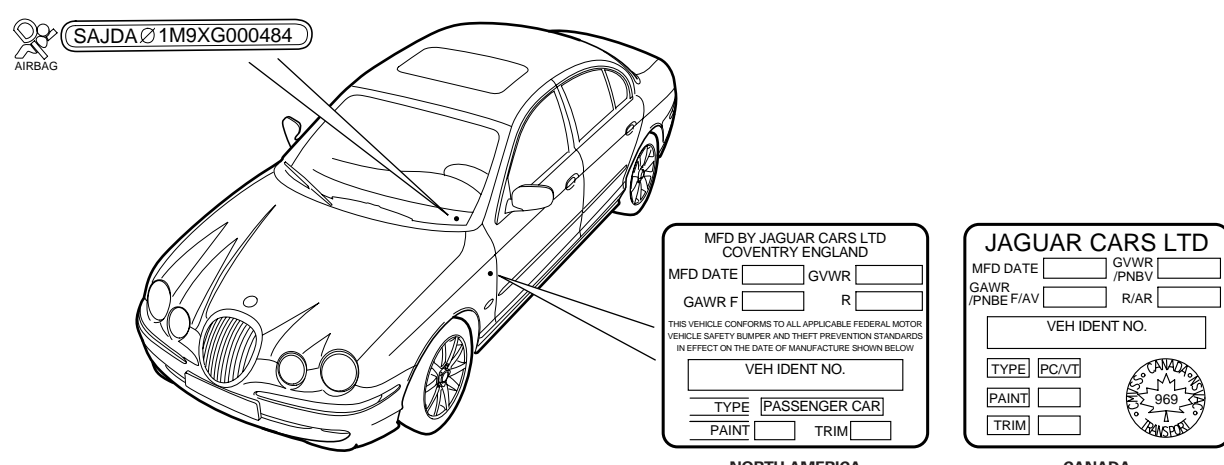

NORTH AMERICA

CANADA

INTR.109

NOTES

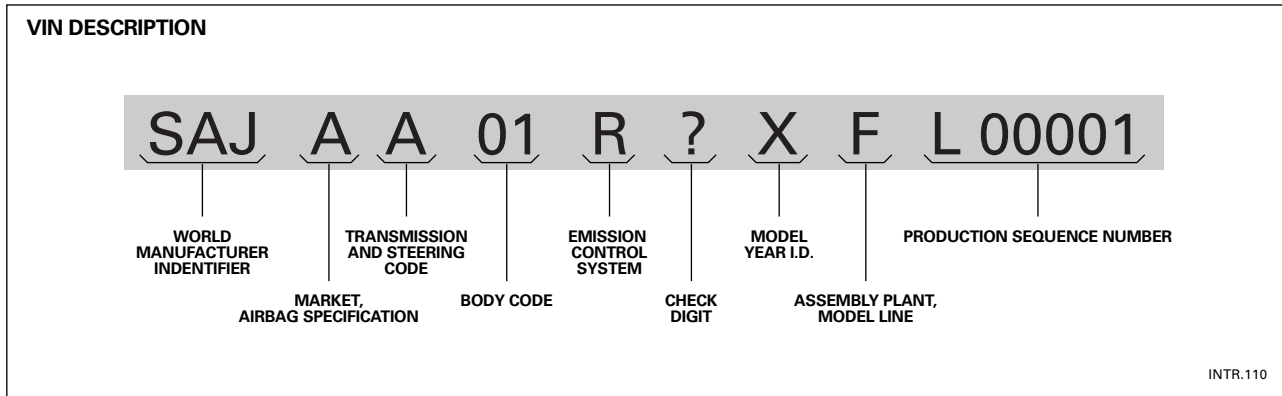

Production Sequence Numbers

S-TYPE Models 3.0-liter V6, 4.0-liter V8

Model Year	Production Sequence Numbers
2000 (Model year I.D. "Y")	L00001 – L77677
2001 (Model year I.D. "1")	L77678 – L86901
2002 Update (Model year I.D. "1")	L86902 – M21729
2002 (Model year I.D. "2")	M21730 – M44997

NOTES

INTRODUCTION TO JAGUAR



1 INTRODUCTION TO XJ/XK

2 INTRODUCTION TO S-TYPE

2.1 Overview

2.2 Engine

2.3 PTEC Engine Management

2.4 Transmission

2.5 Suspension, Steering and Brakes

2.6 DATC Climate Control

2.7 Electrical Distribution System

2.8 Body Systems

2.9 Occupant Protection

2.10 Task Sheets



ENGINE

AJ-V6 ENGINE

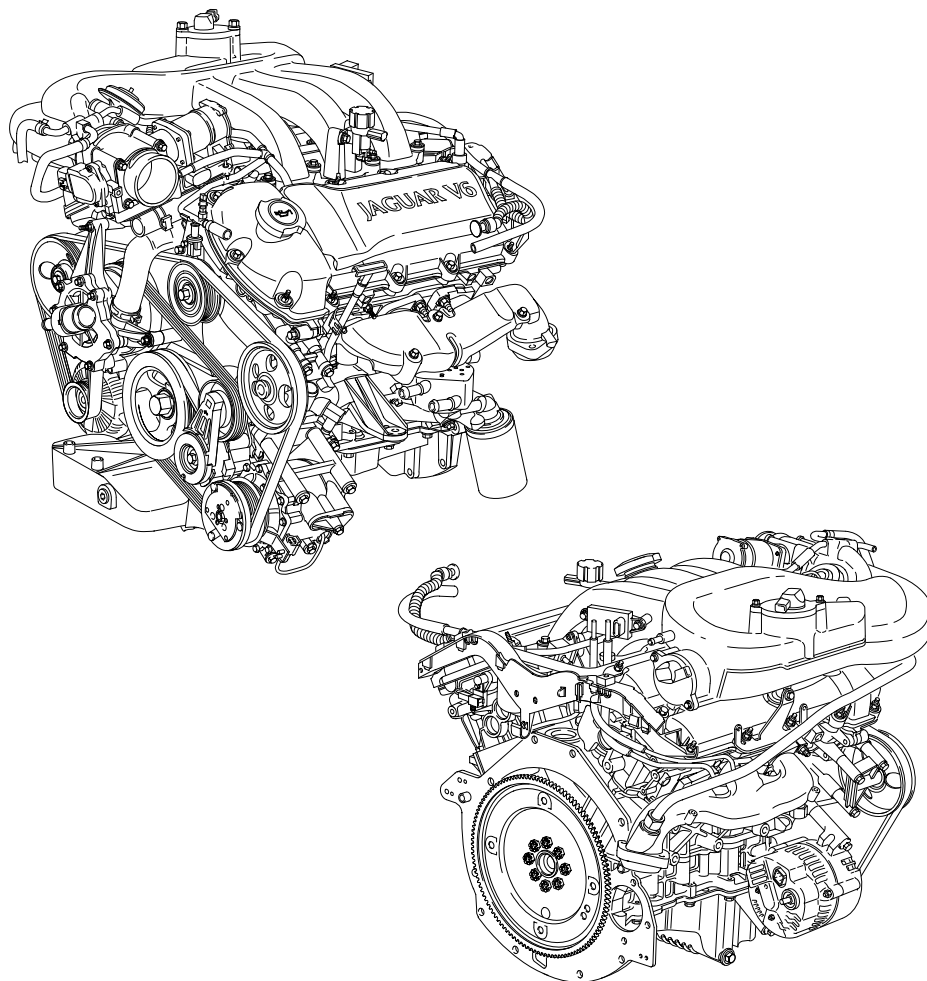

INTR.111

The S-TYPE sports sedan has an in-line powertrain and rear wheel drive configuration and is available with either a 3-liter V6 or a 4-liter V8 engine, both normally aspirated. The V6 engine, designated AJ-V6 is new to the Jaguar range and provides expected Jaguar levels of performance with smooth power delivery, economy and excellent torque characteristics across the engine speed/load range. The engine is of a lightweight but rigid design with particular attention paid to minimizing noise and vibration. A major innovation is the use of a variable geometry air intake manifold, which is controlled, via valves, by the engine management system and produces optimized volumetric efficiency at all engine speeds. Two stage variable valve timing is also fitted and both systems are optimized together to achieve the wide torque delivery at all engine speeds.

The V8 engine, designated AJ28, is a development of the now established engine fitted to XJ and XK vehicles and incorporates the latest modifications fitted to the AJ27 variant, in particular the continuously variable valve timing system and air assisted fuel injection.

Both the V6 and V8 engines are fitted with a new, common, electronic throttle which does not require a mechanical cable. Another new feature, also common to both engines, is the use of a returnless fuel system to reduce the formation of fuel vapor (evaporative emissions).

Engine Specifications

	3.0 Liter V6	4.0 Liter V8
Configuration	60° V6	90° V8
Cylinder Head	Dual overhead camshafts, 4 valves per cylinder	Dual overhead camshafts, 4 valves per cylinder
Valve Clearances (Cold): Intake Exhaust	0.175 to 0.225 mm 0.325 to 0.375 mm	0.18 to 0.22 mm 0.23 to 0.27 mm
Firing Order	1,4,2,5,3,6	1A, 1B, 4A, 2A, 2B, 3A, 3B, 4B
Bore	89 mm (3.504 in)	86 mm (3.386 in)
Stroke	79.5 mm (3.13 in)	86 mm (3.386 in)
Displacement	2.967 liters (181 in ³)	3.996 liters (244 in ³)
Compression Ratio	10.5 : 1	10.75 : 1
Maximum Power (DIN)	179 kW (240 BHP) at 6800 rpm	209 kW (281 BHP) at 6100 rpm
Maximum Torque (DIN)	300 Nm (221 lb ft) at 4500 rpm	390 Nm (287 lb ft) at 4300 rpm
Coolant Volume (complete system)	10.4 liters (11 qts.)	10 liters (10.6 qts.)

V6 Engine Structure

Basic engine construction is similar to the V8 in that a structural bedplate is used which bolts to the cylinder block to provide a very strong housing for the crankshaft, minimizing vibration. Both units are of cast aluminum alloy and are accurately aligned together by the use of eight hollow dowels.

The cylinder block is fitted with dry cast iron liners.

The oil sump is an aluminum alloy casting which combines a sump body and oil pan in a single structural component. The sump mounts to the bedplate via an aluminum gasket incorporating a silicone rubber seal.

NOTES

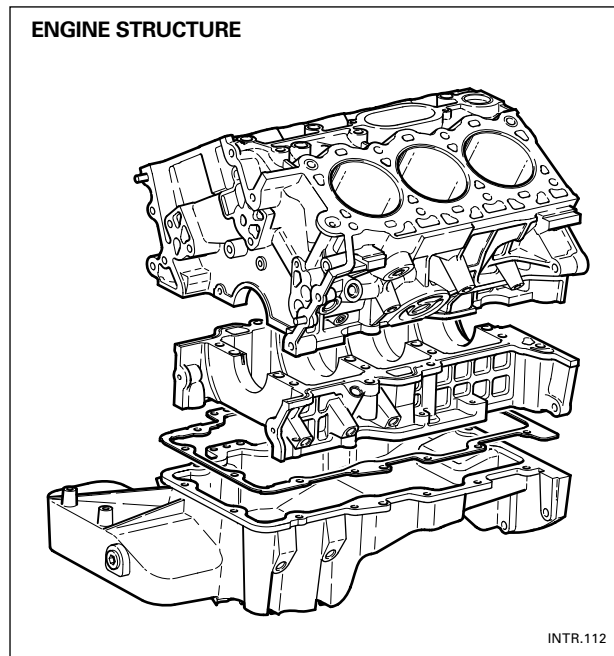

ENGINE

Engine Identification Data

An engine identification code tag is located on the bank 2 side of the front cover assembly. Main bearing selection codes are located at the rear of the cylinder block and on the rear face of the crankshaft flange. The two codes are compared using reference data provided in the JTIS service information to identify the correct bearing.

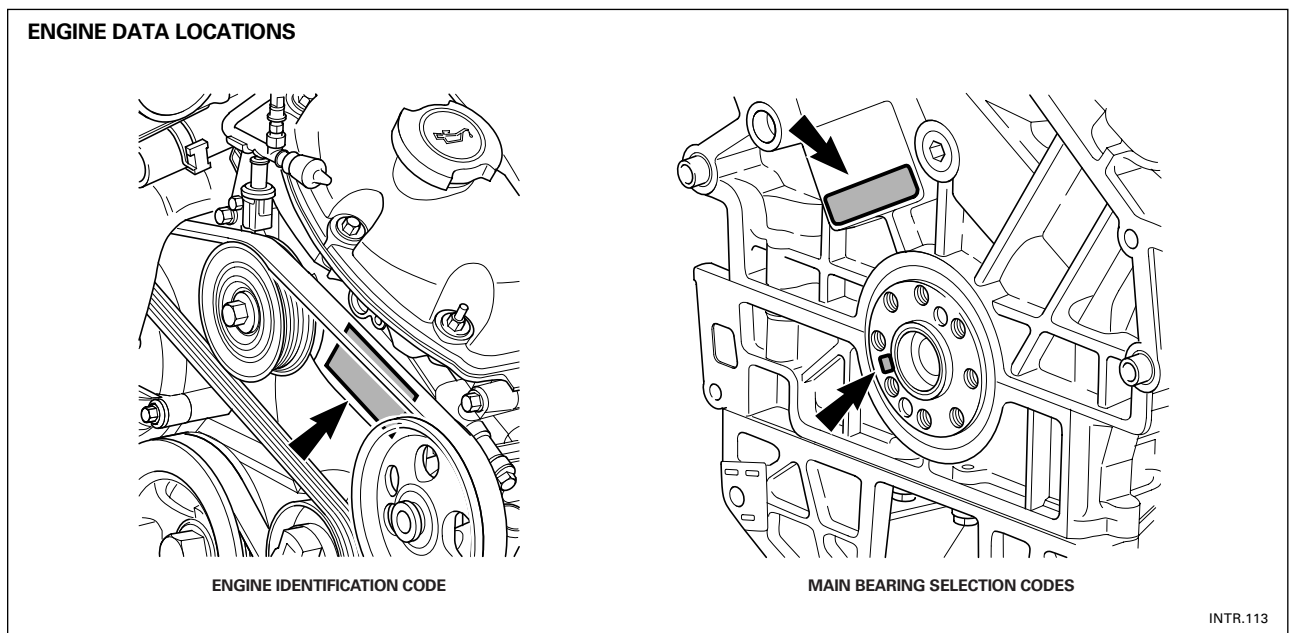

NOTES

INTRODUCTION TO JAGUAR



1 INTRODUCTION TO XJ/XK

2 INTRODUCTION TO S-TYPE

2.1 Overview

2.2 Engine

2.3 PTEC Engine Management

2.4 Transmission

2.5 Suspension, Steering and Brakes

2.6 DATC Climate Control

2.7 Electrical Distribution System

2.8 Body Systems

2.9 Occupant Protection

2.10 Task Sheets



PTEC SYSTEM

Overview

The PTEC (Powertrain Electronic Control) system is a comprehensive combined engine and transmission control system. The system is used on both the 3 liter AJ-V6 and the 4 liter AJ28 V8 engines installed in the Jaguar S-TYPE. There are detailed sensor and control differences between V6 and V8, however the majority of the system is identical in its functions. PTEC complies with OBD II and is capable of achieving future LEV (Low Emission Vehicle) emission standards.

AJ-V6 ENGINE

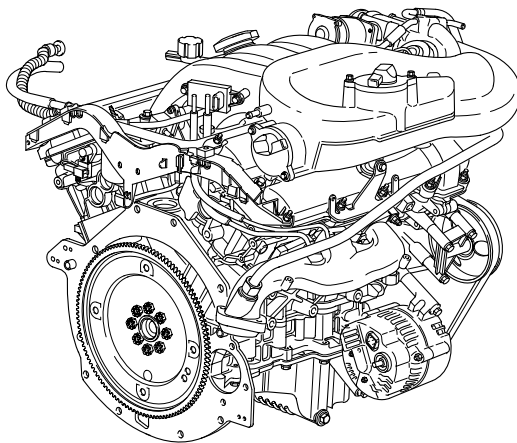
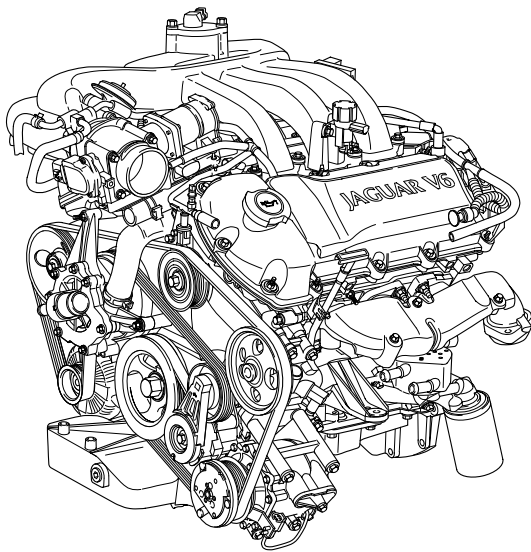

INTR.114

PTEC has several features that are unique from other Jaguar engine management systems:

Single control module

A single Powertrain Control Module (PCM) performs both engine and transmission control functions. This Student Guide covers only the engine management portion of the PTEC system.

SCP Network

PTEC communicates only on the vehicle SCP (Standard Corporate Protocol) multiplex network.

Returnless fuel system

The fuel delivery system is a supply only system with no provision for returning unused fuel from the fuel rail to the fuel tank.

Full authority throttle

PTEC employs a full authority electronic throttle assembly with no cable connection between the accelerator pedal and the throttle. The throttle assembly incorporates a separate control module with diagnostic capabilities.

Variable intake system (V6)

V6 engines are equipped with a variable length air intake manifold that optimizes engine torque across the entire speed/load range.

Fail safe cooling (V6)

V6 engines have a PCM “fail safe cooling” strategy that allows for limited engine operation with low or no coolant.

NOTES

Control Summary

The engine management systems for the 3.0 liter AJ-V6 engine and the 4.0 liter AJ28 V8 engine vehicles are virtually identical in function with differences in the control module parameters and the location of some components.

The major differences between the two systems are as follows:

AJ-V6

Two position VVT (variable valve timing)

Variable air intake system

EGR (exhaust gas recirculation) – 2000 MY only

AJ28 V8

Continuously variable VVT (variable valve timing)

AAI (air assisted injection)

The PTEC powertrain control module (PCM) directly governs the following functions:

- Air assisted fuel injection (V8 only)
- Air conditioning compressor
- Automatic transmission
- Cooling system radiator fan
- Cruise control
- Default operating modes
- Engine power limiting
- Engine speed limiting
- Engine torque reduction control
- Evaporative emission control
- Exhaust emission control
- Exhaust gas recirculation (V6 only)
- Fail safe engine cooling
- Fuel delivery and injection (fuel pump via RECM)
- Fuel system leak check
- Full authority electronic throttle (via Throttle Actuator Control Module)
- Idle speed
- Ignition
- OBD II diagnostics
- Variable intake manifold tuning (V6 only)
- Variable intake valve timing
- Vehicle speed limiting

NOTES

PTEC SYSTEM

Control Summary (continued)

System Logic – V6

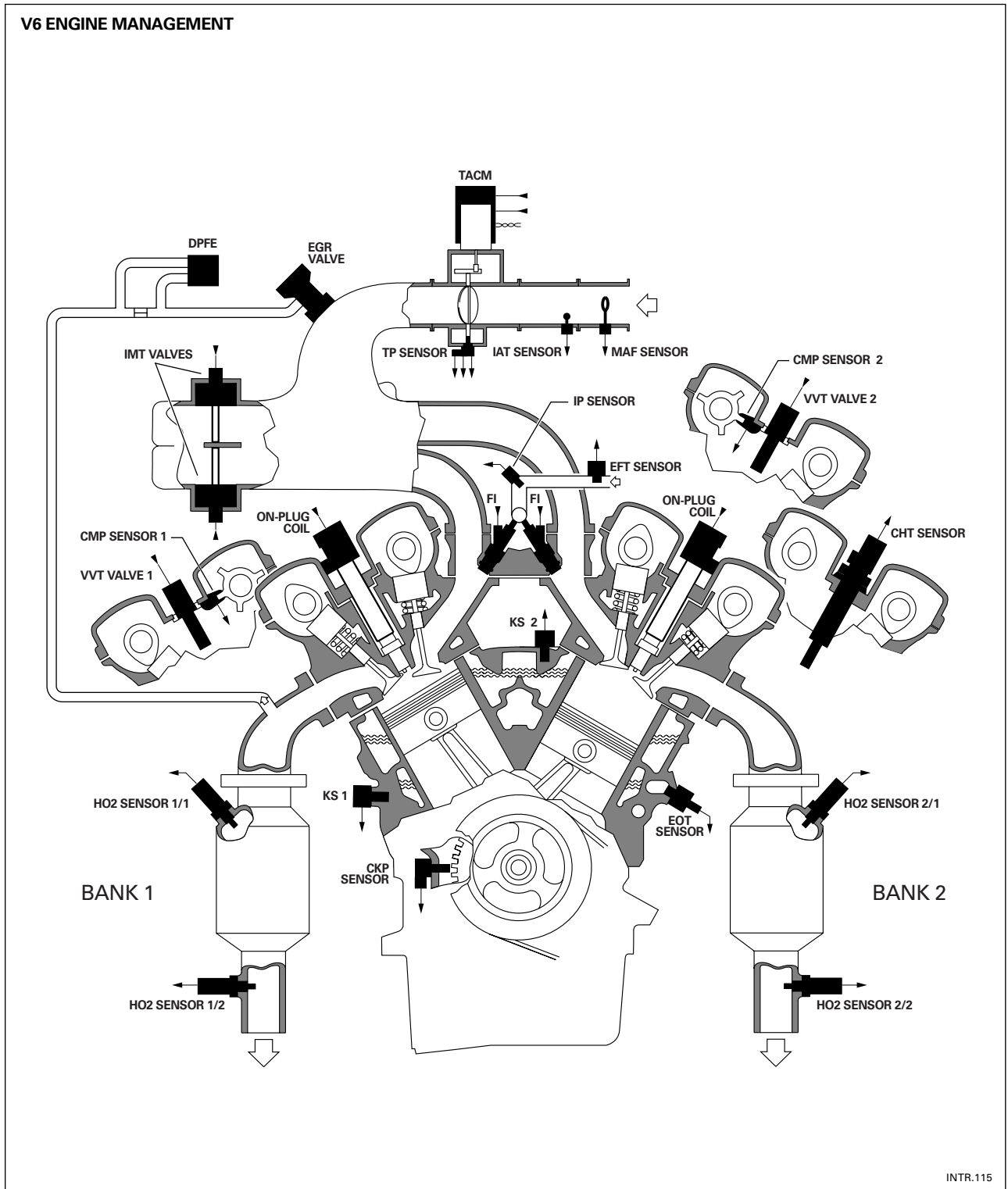

System Logic – V8

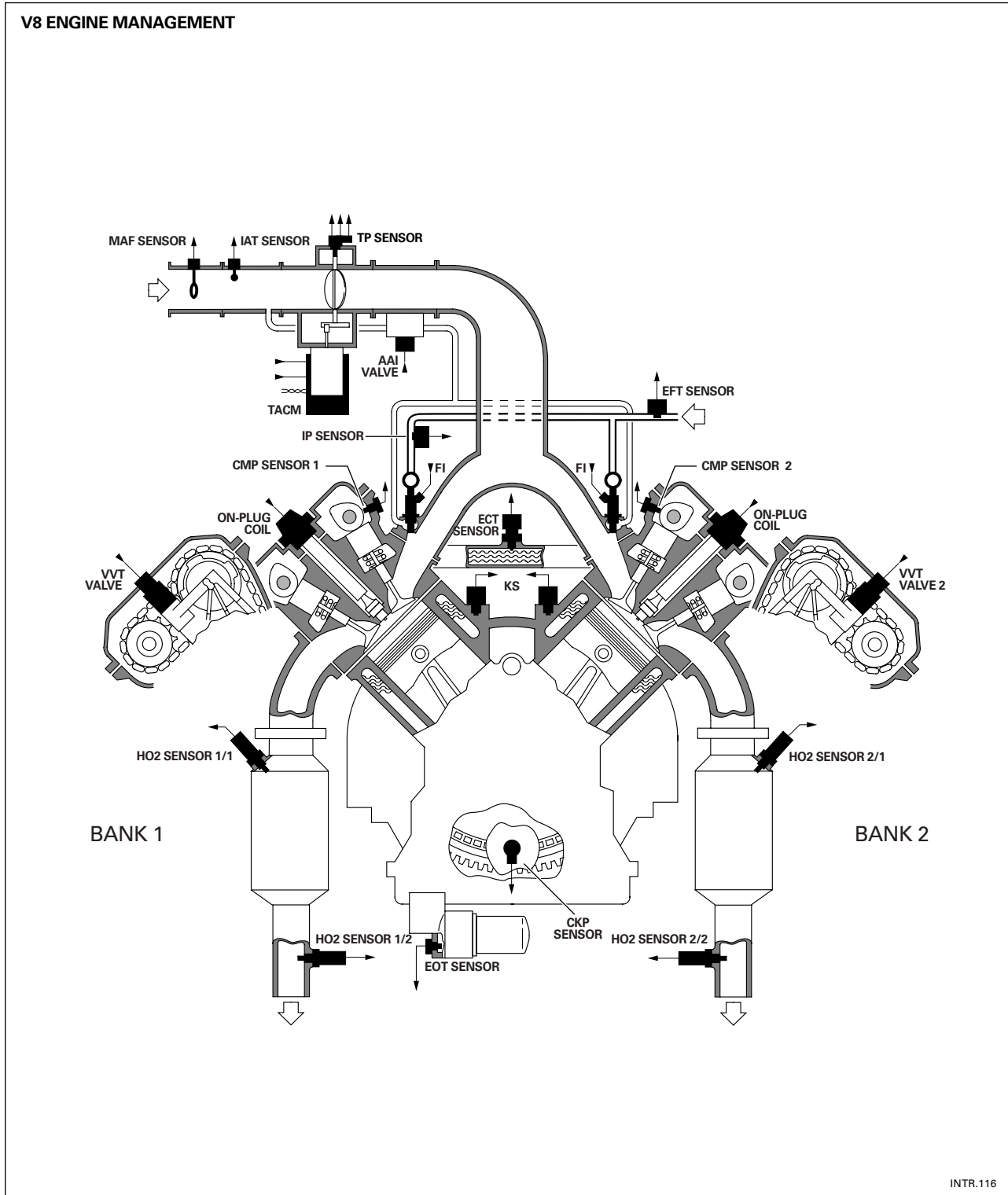

INTR.116

PTEC SYSTEM

Electronic Returnless Fuel System

The electronic returnless fuel system used with the PTEC engine management system provides pressurized fuel at the fuel injectors and does not require a return line with its associated hardware. Additional benefits of the system include:

- Precise fuel pressure control
- Reduced fuel temperature and fuel tank vapor caused by constant fuel recirculation
- Reduced electrical system load
- Fuel pressure boost to prevent fuel vapor lock
- Reduce hot start cranking time

Fuel delivery volume and pressure from the single in-tank fuel pump are controlled by the PCM in a closed loop. The actual fuel pump “drive” is supplied and controlled by the Rear Electronic Control Module (RECM), which receives fuel pump control input from the PCM. The PCM / RECM fuel pump control circuit is hard wired.

The system delivers the correct amount of fuel to the engine under all conditions and at a constant pressure differential with respect to manifold absolute pressure, without the need for a return line to the tank or a fuel rail pressure regulator.

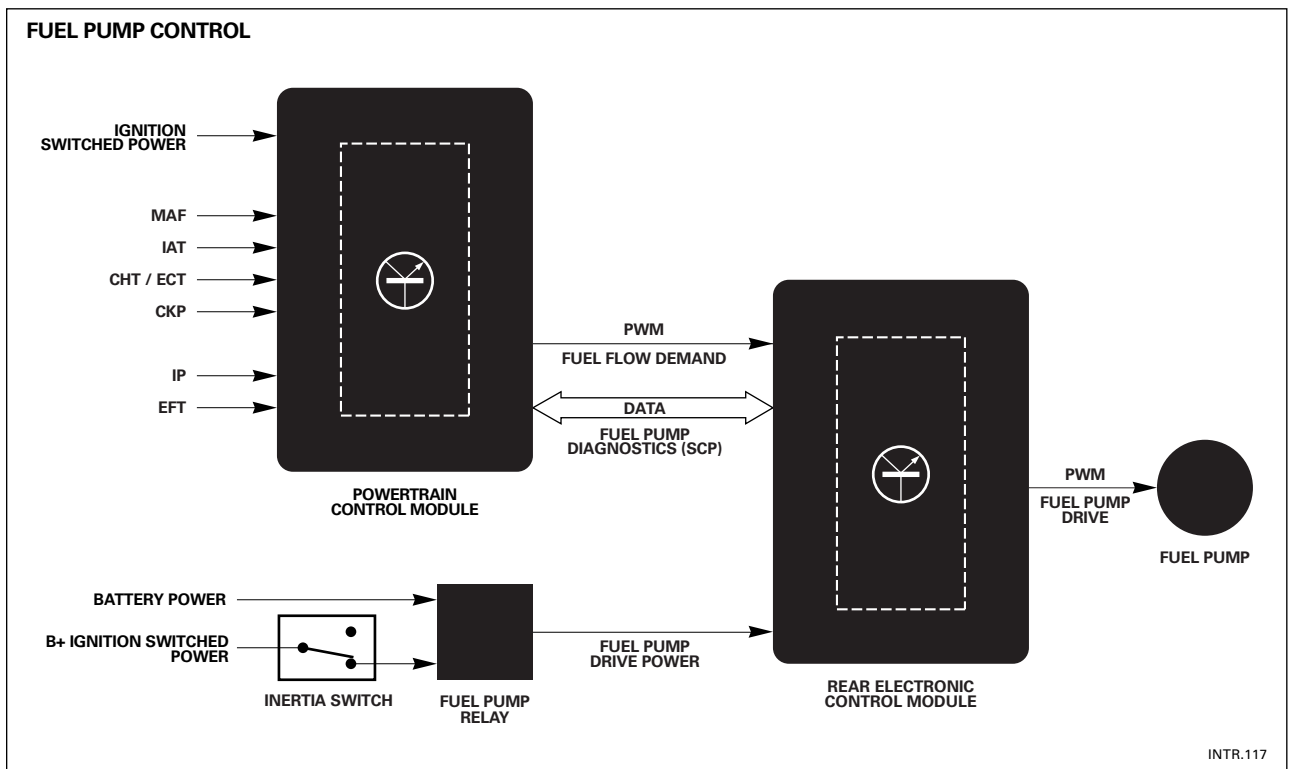

NOTES

Inertia switch

The inertia switch is located behind the trim on the left side of the vehicle, forward of the front door post and below the fascia. A finger access hole in the trim allows the switch to be reset.

If the inertia switch is tripped, it interrupts the ignition switched B+ voltage supply circuit to the fuel pump relay coil. The direct B+ voltage fuel pump supply to the RECM is interrupted and the pump immediately stops.

NOTES

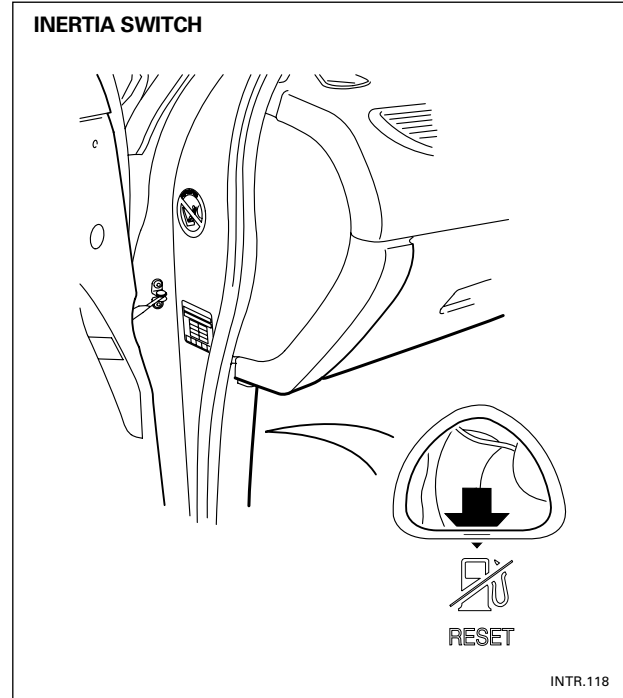

PTEC SYSTEM

Electronic Returnless Fuel System (continued)

Fuel flow

- The variable speed fuel pump is contained in a fuel reservoir in the RH compartment.
- Fuel is pumped from the reservoir through an external crossover pipe to the LH compartment where it flows via a “T” junction to the parallel pressure relief valve and then out to the engine fuel rail.
- The reservoir fuel level is maintained by the continual flow of fuel supplied by jet pumps in the LH and RH compartments.

Fuel from the LH compartment is pumped through an external crossover pipe to the reservoir. The RH compartment jet pump is located in the base of the reservoir.

Parallel pressure relief valve

The parallel pressure relief valve assembly contains two spring-loaded valves, which operate in opposite directions:

- The supply valve opens to allow fuel flow at approximately 0.014 Bar (0.2 psi) during normal operation.
- The fuel rail pressure relief valve opens at approximately 4.14 – 4.48 Bar (60 – 65 psi) to relieve excessive fuel rail pressure.

The main functions of the parallel pressure relief valve assembly are:

- To ensure fast engine starting by “checking” fuel in the supply lines and rail.
- To limit rail pressure due to temporary vapor increase during hot soak conditions (temperature and thus pressure drop after approximately 20 minutes.)
- To limit rail pressure caused by sudden load changes such as a full to closed throttle transition.
- To prevent siphoning from the tank in the even of the fuel line being severed with the pump inactive.

NOTES



INTRODUCTION TO S-TYPE

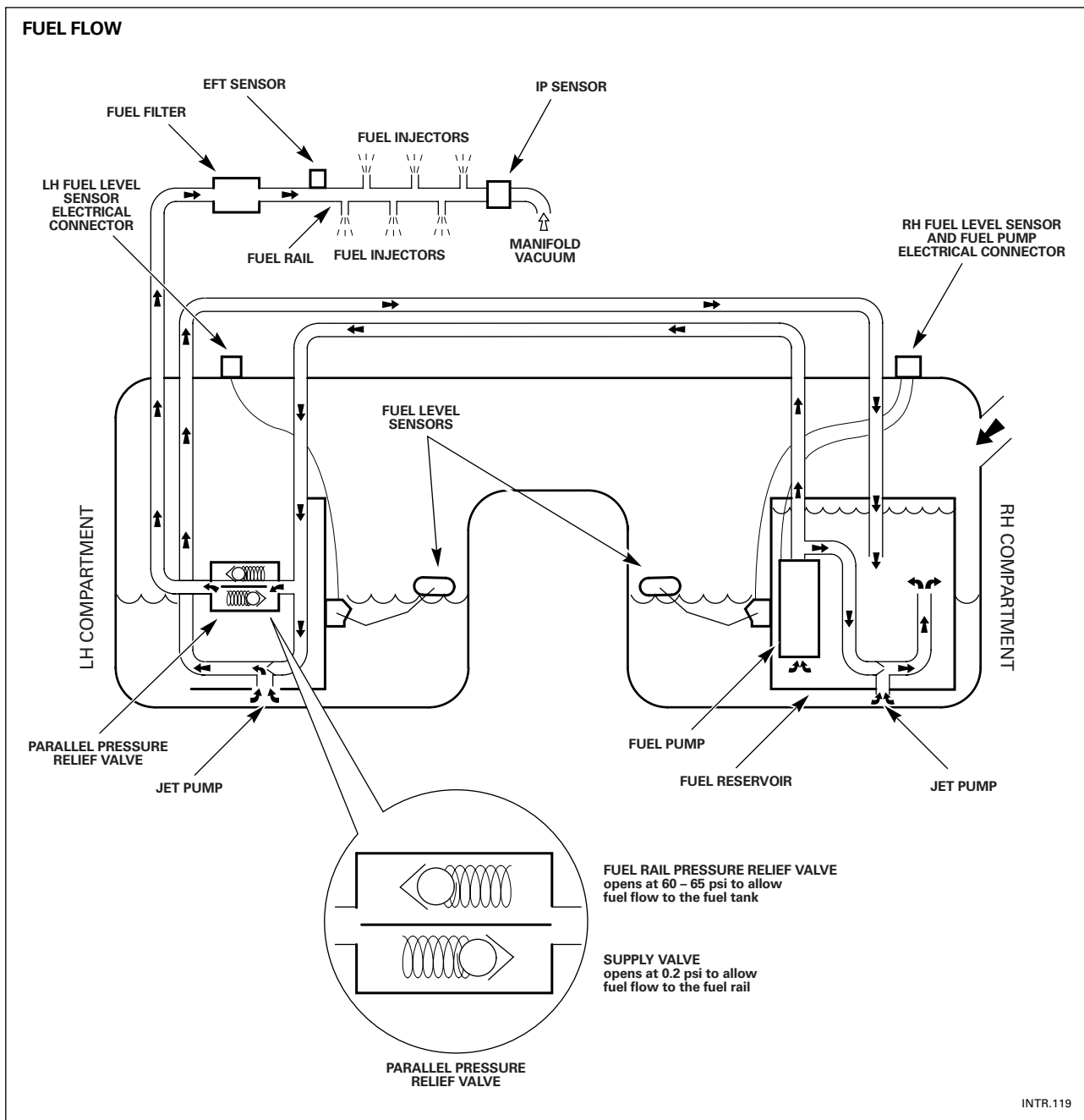

INTRODUCTION TO JAGUAR



1 INTRODUCTION TO XJ/XK

2 INTRODUCTION TO S-TYPE

2.1 Overview

2.2 Engine

2.3 PTEC Engine Management

2.4 Transmission

2.5 Suspension, Steering and Brakes

2.6 DATC Climate Control

2.7 Electrical Distribution System

2.8 Body Systems

2.9 Occupant Protection

2.10 Task Sheets



TRANSMISSION

5R55N Automatic Transmission

V6 and V8 Jaguar S-TYPE vehicles are equipped with the 5R55N 5-speed automatic transmission system. The transmission design for both vehicles is identical with slight mechanical differences to account for engine power and configuration, as well as the installation in the vehicle. The V6 requires a transmission with a longer rear extension housing and output shaft assembly to accommodate the shorter engine. Each variant uses a unique torque converter matched to the engine torque requirement. The V8 uses an adapter plate to mate the torque converter to a large diameter drive plate.

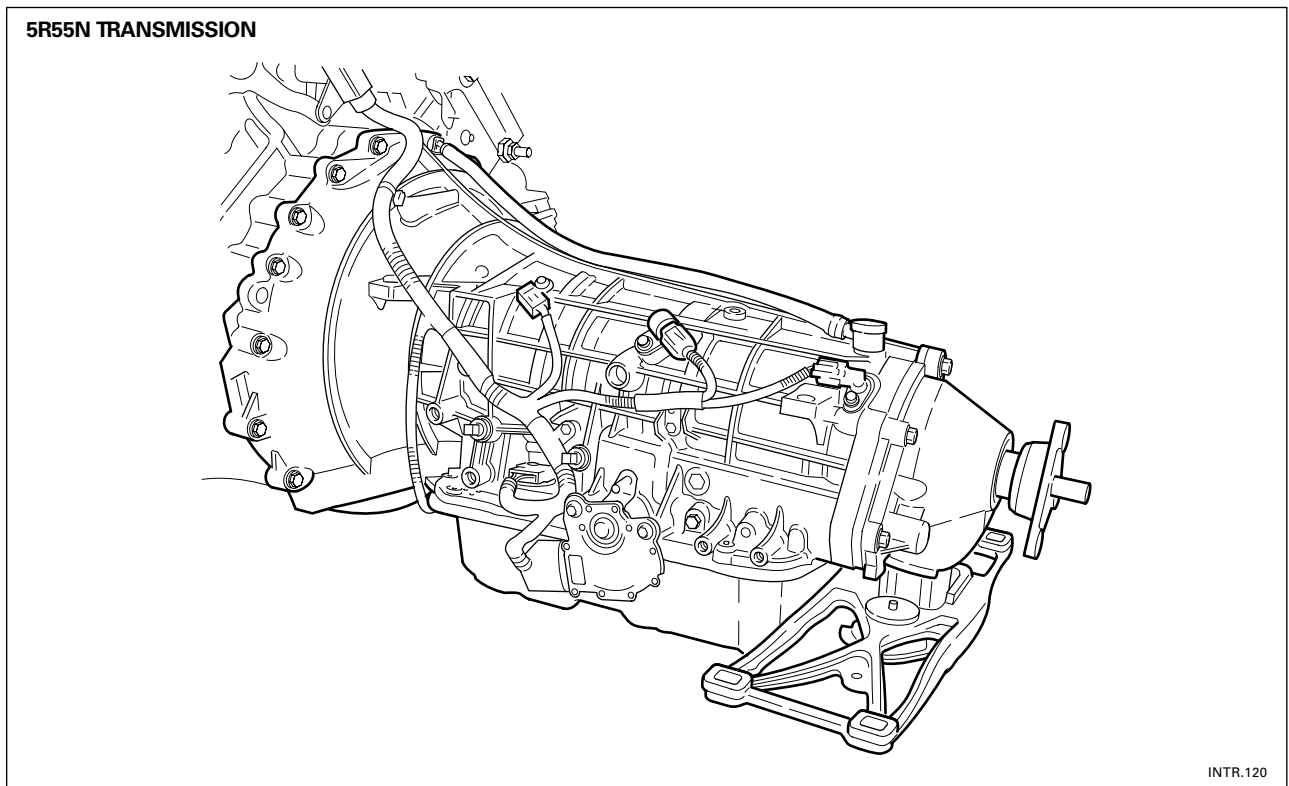

The transmission is electronically controlled by the Powertrain Control Module (PCM), which integrates Engine Management System control. The combined system is known as PTEC – Powertrain Electronic Control. The single control module for both engine and transmission eliminates the need for a high speed Controller Area Network (CAN).

Normal P,R,N,D drive functions plus manual selection of 4th, 3rd and 2nd gears are provided by a Jaguar style 'J' gate (not the same as XJ and XK Series). Sports or Normal mode is selected by the switch located at the 'J' gate.

NOTES

Specifications

5 R 55 N 5 = Five forward gears
 R = Rear wheel drive
 55 = Torque capability code number
 N = Type code

Transmission weight with fluid: 90 kg (198 lb.)

Mechanical features: Five forward gears
 Three compound planetary gear sets
 Three brake bands
 Four multi-plate clutches
 Three one-way clutches

Transmission fluid: Capacity – 9 liters (9.5 quarts)
 Fill / change – filled for life
 Type – Mercon V Semi-Synthetic
 Jaguar Part Number JLM 21044 (1 liter)

Transmission fluid cooler: External, separate air-to-liquid cooler located below the air conditioning condenser.

Towing: 35 mph for 50 miles

Power is transmitted from the torque converter to the planetary gear sets through the input shaft. Brake bands and clutches are used to hold and drive certain combinations of gear sets to produce five forward gears and one reverse gear, which is transmitted to the output shaft and differential.

	1st gear	2nd gear	3rd gear	4th gear	5th gear	Reverse
Gear ratios	3.25 : 1	2.44 : 1	1.55 : 1	1.00 : 1	0.75 : 1	3.07 : 1

NOTES

TRANSMISSION

Driveline

Driveshaft

The S-TYPE has a two-piece welded steel tube driveshaft with a splined center slip joint and locking collar, the whole being aligned with the body centerline. The driveshaft has rubber flex couplings and a rubber, body-mounted, center bearing. For safety, the front tube is collapsible. Serviceable parts are the center bearing, flex coupling, rubber boot, alignment bearing and fasteners. Lubrication of the driveshaft components is unnecessary. The universal joint is equipped with nylon thrust washers, located at the base of the bearing cup.

Balancing of the driveshaft is achieved using a PDU with the new vibration analyzer. This gives details of where the shaft is out of balance and by how much and where to place the balance nuts.

Final Drive (differential)

The final drive, differential, has a steel case and rear cover, no drain plug and has a sealed for life lubricant. The hypoid gearset is mounted in taper roller bearings. It has a two point differential assembly retained by bearing straps. The central pinion is on the body centerline. Pinion and output oil seals, the companion flange and nut and the needle roller output bearing are the only serviceable items.

Final drive ratios are:

3.31:1 (V6 and V8 auto)

2.87:1 (V6 manual)

Half-shafts

Half-shafts are unequal lengths and are therefore handed, left and right. Constant velocity joints are fitted to both ends, the outer is fixed and the inner is sliding. They are sealed for life and retained in the differential side gear with a spring clip.

NOTES

DRIVELINE ARRANGEMENT

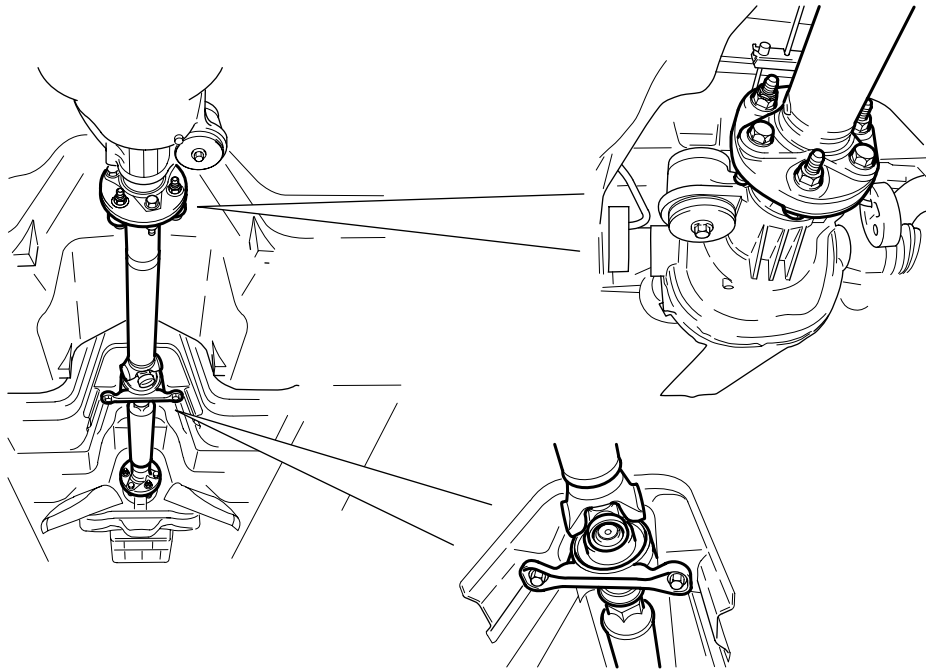

INTR.121

INTRODUCTION TO JAGUAR



1 INTRODUCTION TO XJ/XK

2 INTRODUCTION TO S-TYPE

2.1 Overview

2.2 Engine

2.3 PTEC Engine Management

2.4 Transmission

2.5 Suspension, Steering and Brakes

2.6 DATC Climate Control

2.7 Electrical Distribution System

2.8 Body Systems

2.9 Occupant Protection

2.10 Task Sheets



SUSPENSION, STEERING AND BRAKES

Front Suspension

The independent front wheel suspension is a double wishbone axle arrangement with aluminum control arms. The two arms are of different lengths, which minimizes the changes in track and camber. Inclination of the upper control arm axis provides anti-dive front suspension action. There are two front cross members, known as Number 1 and Number 2.

Number 1, the forward cross member, is a steel fabrication, non-isolated, which locates the lower control arm front mounting, the anti-roll bar and the cooling module.

The rear cross member, Number 2, is an aluminum casting, non-isolated and it locates the lower control arm rear mounting, the power steering rack and the engine hydro-mounts.

WARNING: NO ATTEMPT MUST BE MADE TO WELD OR REPAIR THE ALUMINUM CROSSMEMBER. IF IT IS DAMAGED, A NEW ONE MUST BE INSTALLED.

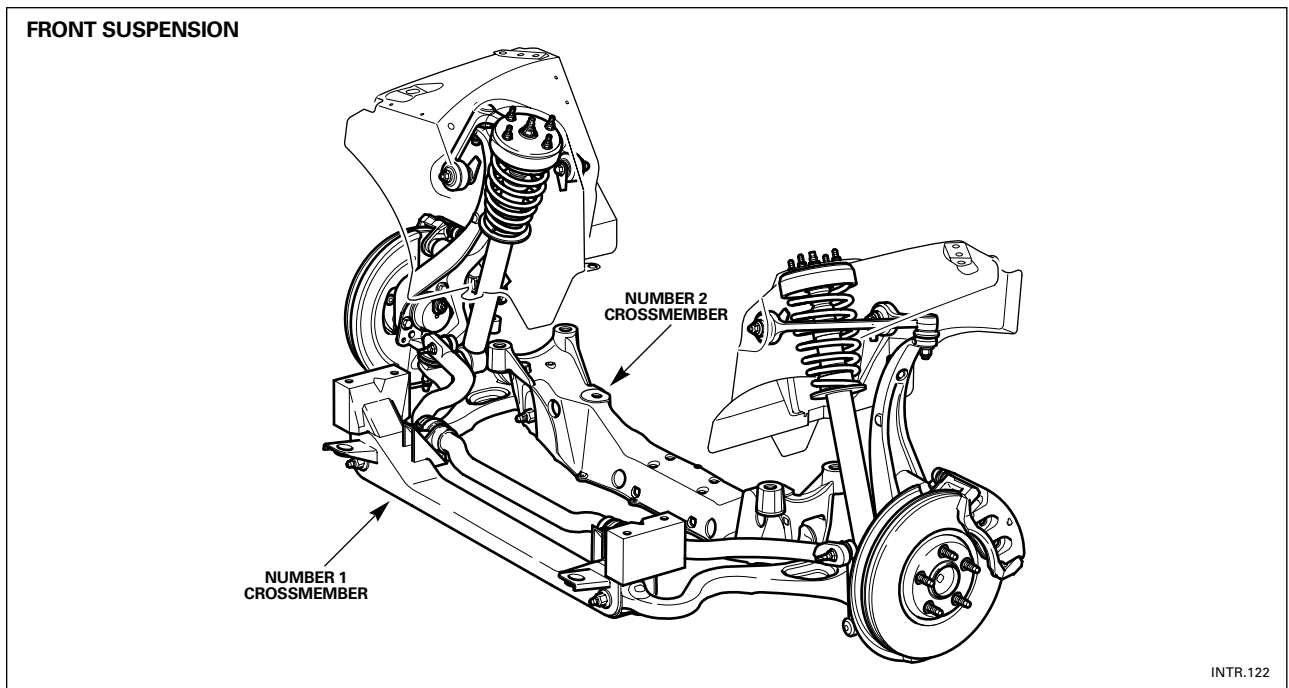

Suspension Alignment

A special tool has been designed to enable correct alignment of the suspension to the body.

Connected to a personal computer, a transducer with a wire measuring device is fitted to a plate attached to the Number 2 cross member. Alignment pins are fitted to the body front and rear to the left-hand side chassis rail and to the rear suspension beam. Measurements are taken from one point on the Number 2 beam. Then the transducer is transferred to the other point on the beam and a second set of measurements taken. The PC then calculates if there is any misalignment and by how much, and displays the information on the screen. The beam(s) are then adjusted to bring the alignment back within limits and a further series of measurements are taken. This process is repeated until the alignment is correct and the beams are then tightened. A printout of the measurements is to be attached to the job card as a permanent record of alignment. Note that camber, caster and toe may be required if any of the beams have been adjusted.

Lower Control Arm

The lower control arm is an aluminum forging and has locations for the damper and the anti-roll bar drop link. It is mounted with one hydro-bush, the front lower bush, and one rubber bush, both serviceable. This is the first time that a hydraulic bush has been fitted to a Jaguar wishbone. The hydro-bush is tuned for refinement and helps to reduce brake vibration.

Service adjustments for caster and camber can be made to the lower control arm geometry with the addition of cam bolts (not supplied with the vehicle).

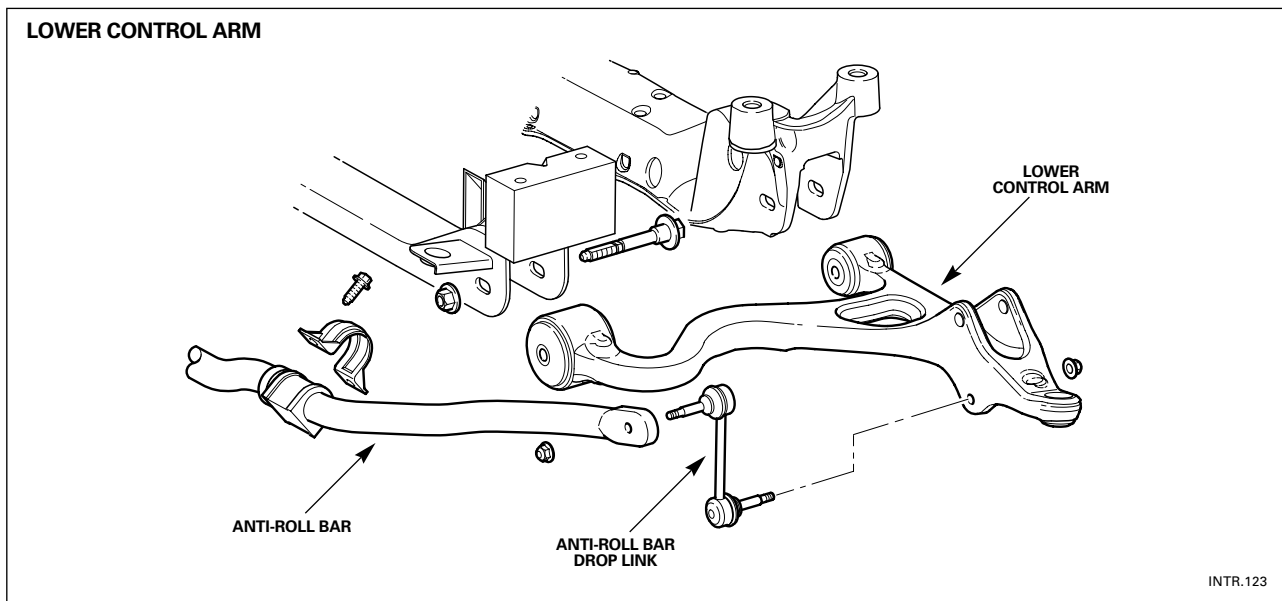

Vertical Front Knuckle

The vertical front knuckle is an aluminum casting with integral steering arm, installed between the upper and lower control arms. The lower ball joint is serviceable and is a press fit. The knuckle locates the upper ball-joint, riveted disk shield and brake caliper and wheel bearing/hub. The wheel bearing is a new type and contains the integral ABS rotor and sensor. The bearing is not serviceable and must be replaced as a complete unit. A service kit is available for the ABS sensor.

NOTES

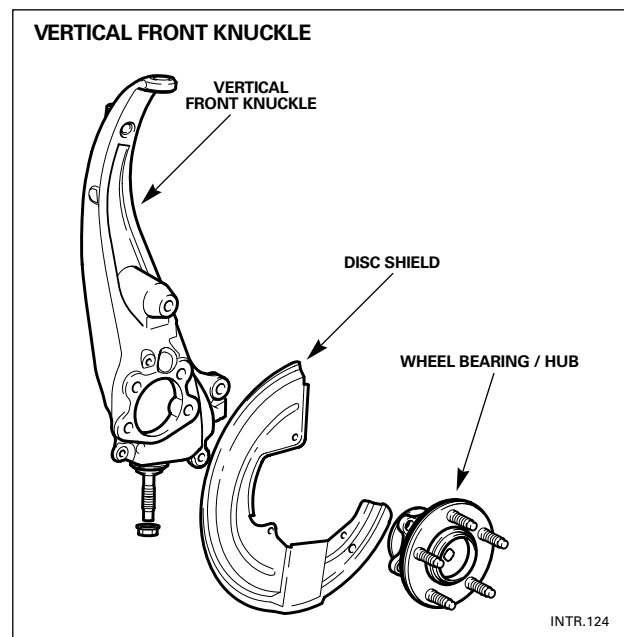

SUSPENSION, STEERING AND BRAKES

Rear Suspension

The rear suspension is a double wishbone arrangement with aluminum control arms. The rear crossbeam is steel fabricated and isolated to the body with four bushes. The crossbeam locates the upper and lower control arms and the anti-roll bar.

Control arms are aluminum castings and heavily inclined in plan view. The lower control arm locates the damper and anti-roll bar drop link. The damper fixing is tapped into the aluminum casting. The upper control arm has one cross axis bush and one rubber bush. It contains an integral balljoint.

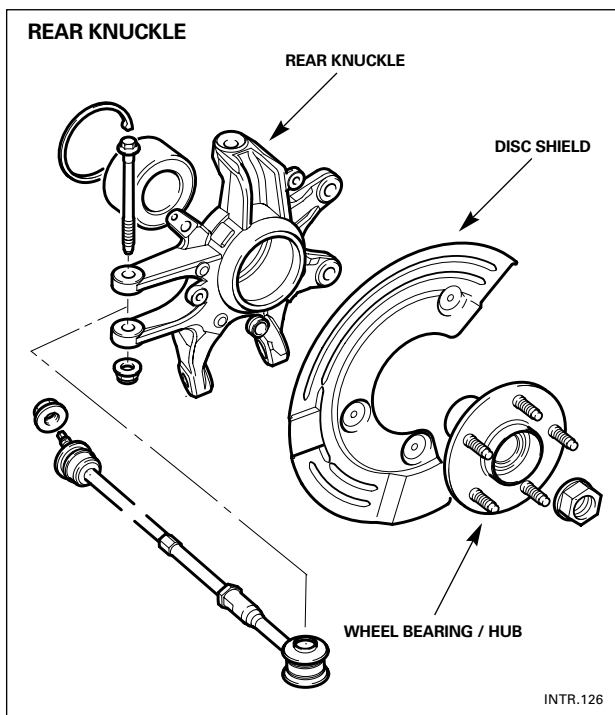
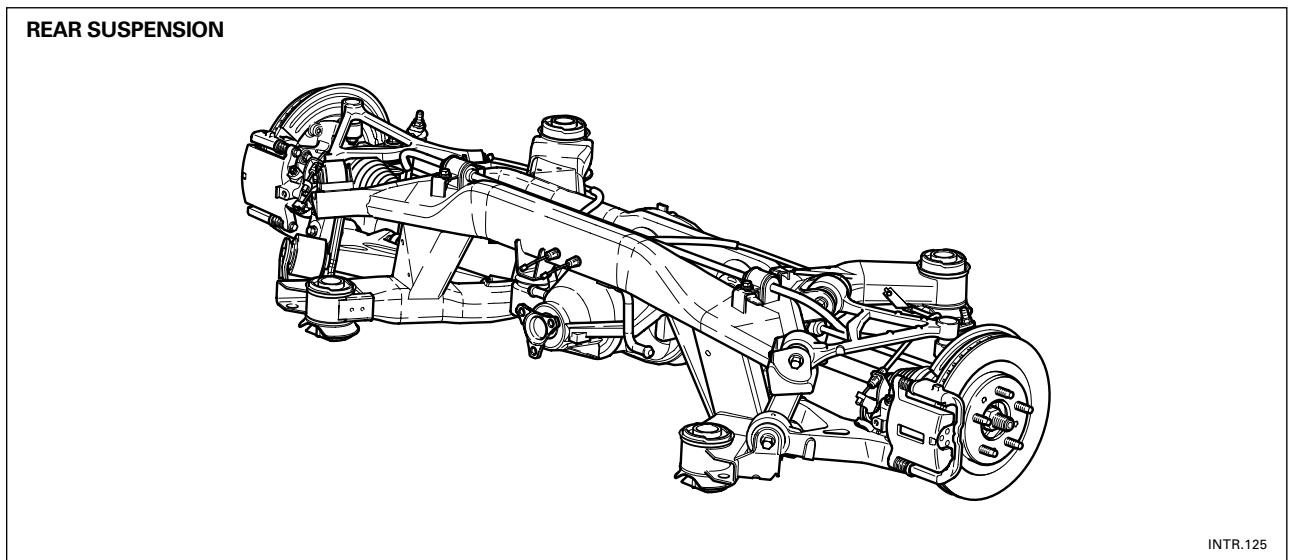

Rear Knuckle

The rear knuckle is an aluminum casting and has a press fit cartridge bearing.

The independent rear suspension upper and lower front bushes are conventional rubber bonded bushes. The upper and lower rear bushes contain no rubber and are essentially pressed in 'rose' bearings for superior suspension geometry control. These are common components between all vehicle variants and are a similar concept to the A-frame bush on current sports and saloon vehicles. The bushes are not bonded in place but require a special lubricant when assembling. Care must be taken to ensure that the replacement bushes are pushed fully home, the angular orientation of the bushes is important and it is essential to mark the position of the subframe before removing from the vehicle or else driveline alignment will be lost.

Power Assisted Steering

The Jaguar S-TYPE has a variable assist rack and pinion steering gear and variable rack ratio. The variable steering rack ratio reduces the number of turns from lock to lock (2.8) to enhance parking maneuverability whilst maintaining the on-center steering precision required at high speed. Full power assistance is provided for parking. Steering assistance decreases smoothly at a calibrated rate to raise driver steering efforts as vehicle speed increases.

POWER ASSISTED STEERING RACK

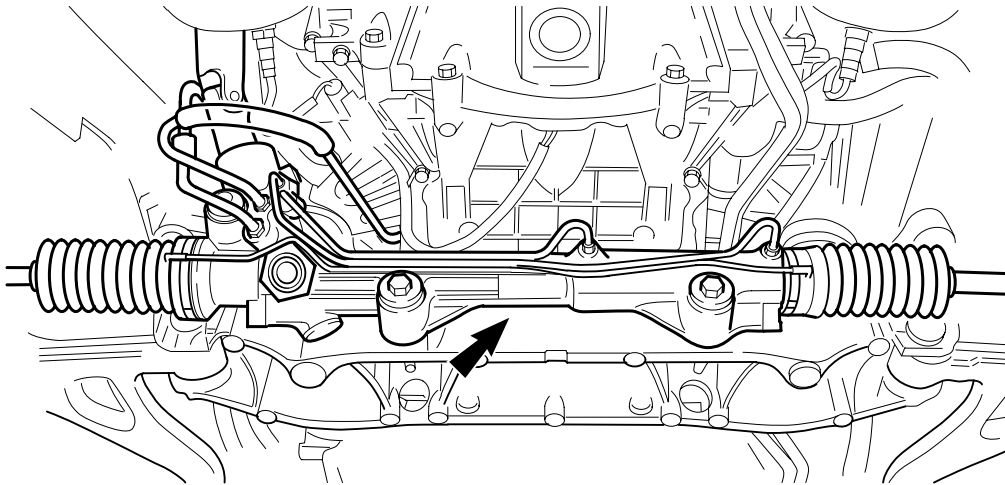

INTR.127

NOTES

SUSPENSION, STEERING AND BRAKES

Brakes

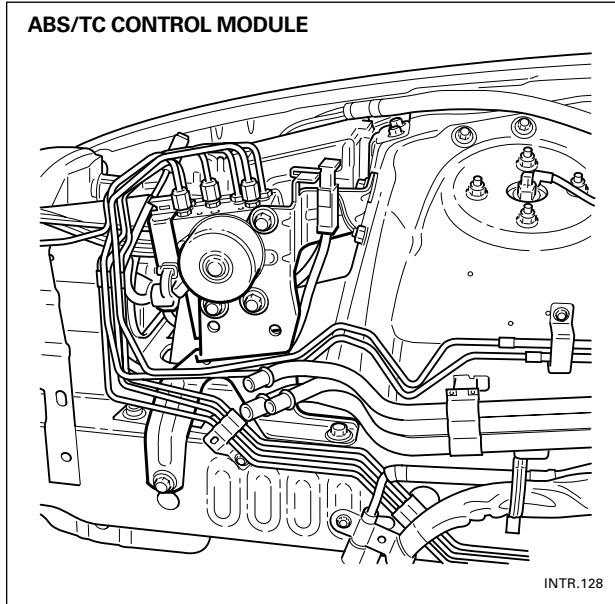

Brake Control Module

Brakes are controlled with a Teves Mk 20E brake modulator.

The anti-lock braking / traction control control module (ABS/TCCM) contains the integral software for ABS and traction control, similar to current XJ and XK vehicles. It is supplied as a 10-valve, 4-channel module and calibration is the same to all powertrains. It is connected to the SCP bus for traction control, warnings and vehicle speed.

Dynamic Stability Control

Dynamic stability control (DSC) is a new Jaguar safety feature, which uses ABS and traction control to control yaw movements of the vehicle. Yaw is the rotary motion of the vehicle on its vertical axis, a force that would cause oversteer or sideslip. The dynamic stability control module (DSCM) contains the same software as described but with the addition of IVD software. The modulator is supplied as a 12 valve, 4-channel module calibrated for base suspension only. The connectors differ between the two; the 10 valve unit has a 25-way with sliding cam, as current vehicles and the 12-valve unit has a 47-way connector with lever cam. DSC calculates the real vehicle motion (forward and gearing) and compares it to the direction initially chosen by the driver. A steering rate sensor is located on the steering column and is used to calculate steering angle. A yaw rate sensor and lateral accelerometer are located on a bracket behind the hand brake lever and are used to calculate the vehicle under or over steer and any side slip.

As soon as DSC recognizes that the driver is not reacting sufficiently to compensate a deviation, DSC intervenes by applying brake force to each of the four wheels individually to control yaw.

NOTES

Brake Booster

The brake booster is a Lucas unit mounted on the engine bay bulkhead with a 25.4mm (1 in.) diameter master cylinder and integral brake fluid reservoir.

NOTE: The reservoir is also a combined brake/clutch reservoir for manual transmission vehicles.

Twin vacuum boosters of 8-inch and 9-inch sizes are fitted.

The DSC booster is different having integral pressure transducers and solenoids with air control valves for the booster. The transducers are located on the brake master cylinder and are used for pressure feedback, brake application and fail safe operation. The booster is used to supply brake pressure without driver input.

ABS operation is no different to current Jaguar vehicles.

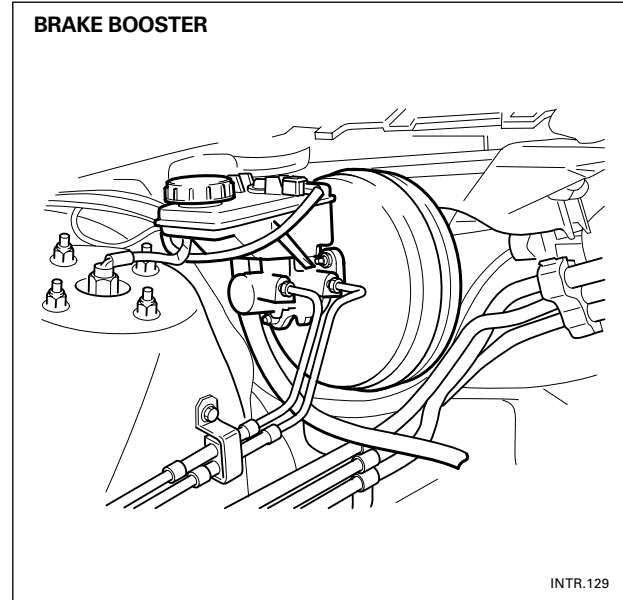

NOTES

INTRODUCTION TO JAGUAR



1 INTRODUCTION TO XJ/XK

2 INTRODUCTION TO S-TYPE

- 2.1 Overview
- 2.2 Engine
- 2.3 PTEC Engine Management
- 2.4 Transmission
- 2.5 Suspension, Steering and Brakes

2.6 DATC Climate Control

- 2.7 Electrical Distribution System
- 2.8 Body Systems
- 2.9 Occupant Protection
- 2.10 Task Sheets



DATC CLIMATE CONTROL

The Dual Automatic Temperature Control (DATC) climate control system is a compact system that provides a complete selection of driver controlled functions and additional automatic functions. The DATC climate control system was designed by Visteon for the Jaguar S-TYPE; most of the DATC functions and controls are similar to the existing Jaguar systems.

Control Summary

The A/CCM automatically maintains the selected driver and passenger interior temperatures and regulates the volume of airflow between the various system outlets. Separate driver and passenger discharge temperatures are made possible by the heater system that incorporates a partitioned dual zone heater core and dual coolant flow control valve.

Air Intake

Depending on the interior temperature when the system is activated, the A/CCM automatically selects between fresh intake air and recirculated cabin air; however, the driver has the option for manually selecting RECIRCULATION / FRESH. If the manual recirculation button is pressed for a short period (one chime), “timed recirculation” is enabled.

Timed recirculation varies with air conditioning compressor status and ambient temperature. If the compressor is off (A/C LED OFF), recirculation will be enabled for 1 to 6 minutes by the A/CCM. If the compressor is on (A/C LED ON), recirculation will be enabled for 1 to 12 minutes by the A/CCM. If the manual recirculation button is pressed for a long period (two chimes), “latched recirculation” is enabled.

All manual recirculation settings are canceled at the next ignition switch cycle.

Discharge Air Temperature

The A/CCM attempts to provide both the driver and the passenger with their selected air temperature. If both of the selected temperatures cannot be achieved, the system is biased in favor of the driver. The rear seat passengers receive the air temperature selected for the person seated directly in front. Fan speed and air distribution are centrally controlled. Pressing and holding the AUTO button for two seconds equalizes the driver and passenger temperature selections.

A feature unique to V8 vehicles allows interior heating to be continued after the engine has been switched off. With the ignition switch in position II, the climate control system will continue to provide interior heating until the engine cools to a predetermined level (maximum 20 minutes).

Diagnostics

All diagnostics are carried out using WDS. No separate “panel diagnostics” are provided.

Voice Control

An optional Voice Activation Control system allows the driver to adjust temperature control without touching the DATC controls.

NOTES

Air Conditioning Control Module

The DATC A/CCM is a single module packaged in the center of the fascia. The control module is microprocessor-based, consisting of a bezel assembly (including all buttons and switches), a main control board and a housing for the assembly. Battery direct and ignition switched B+ power is supplied from the primary junction box.

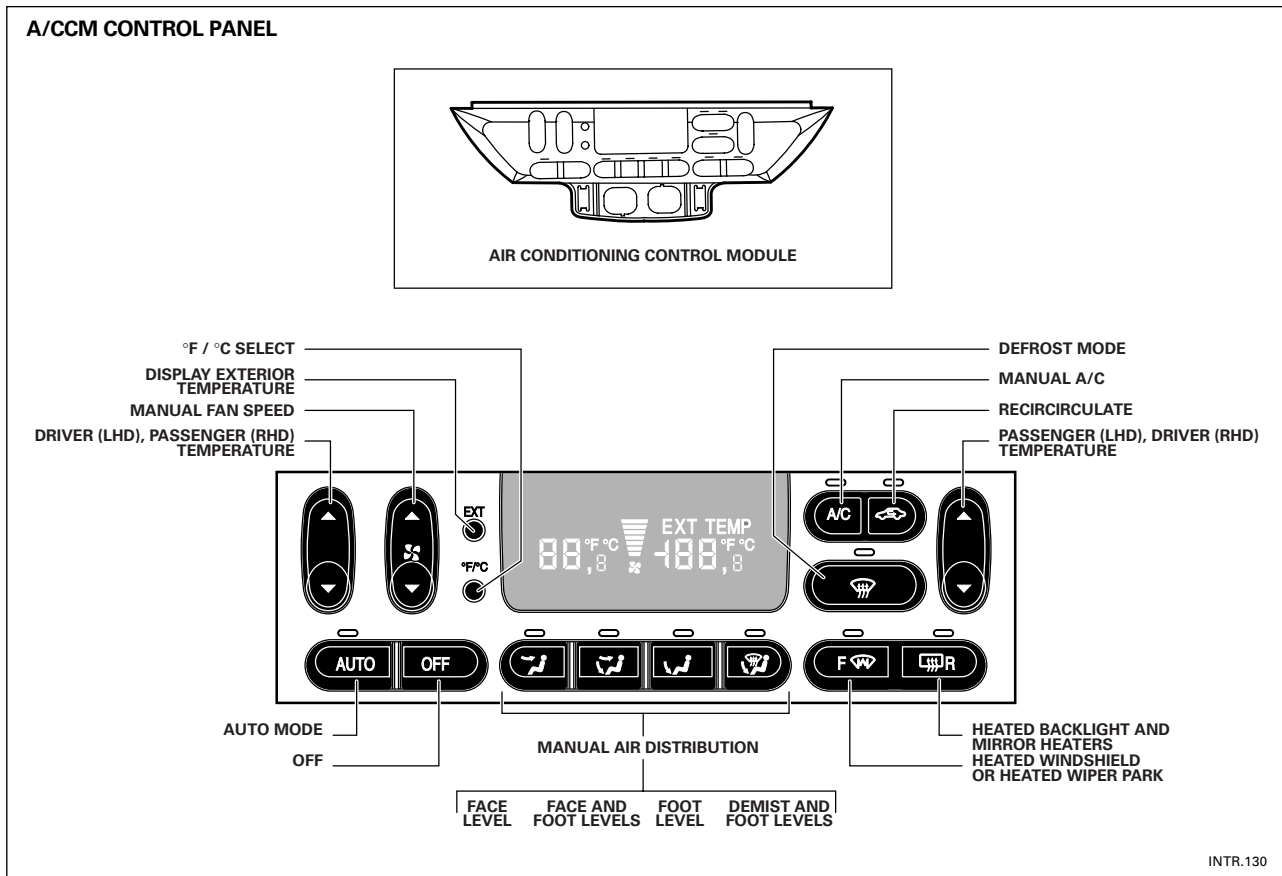

NOTES

DATC CLIMATE CONTROL

Refrigeration System

Jaguar S-TYPE has a conventional R134a air conditioning refrigeration system. The installation of a variable displacement scroll type compressor and the use of an air conditioning pressure sensor are components new to Jaguar. The system does not require the installation of mufflers.

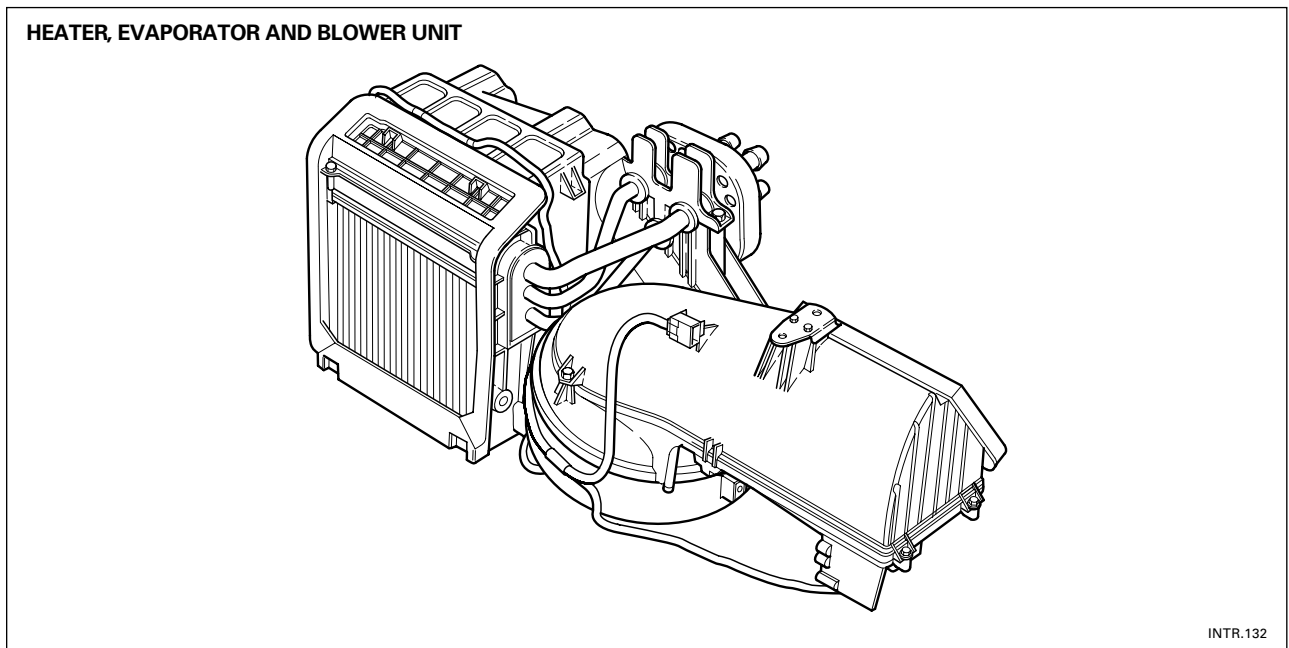
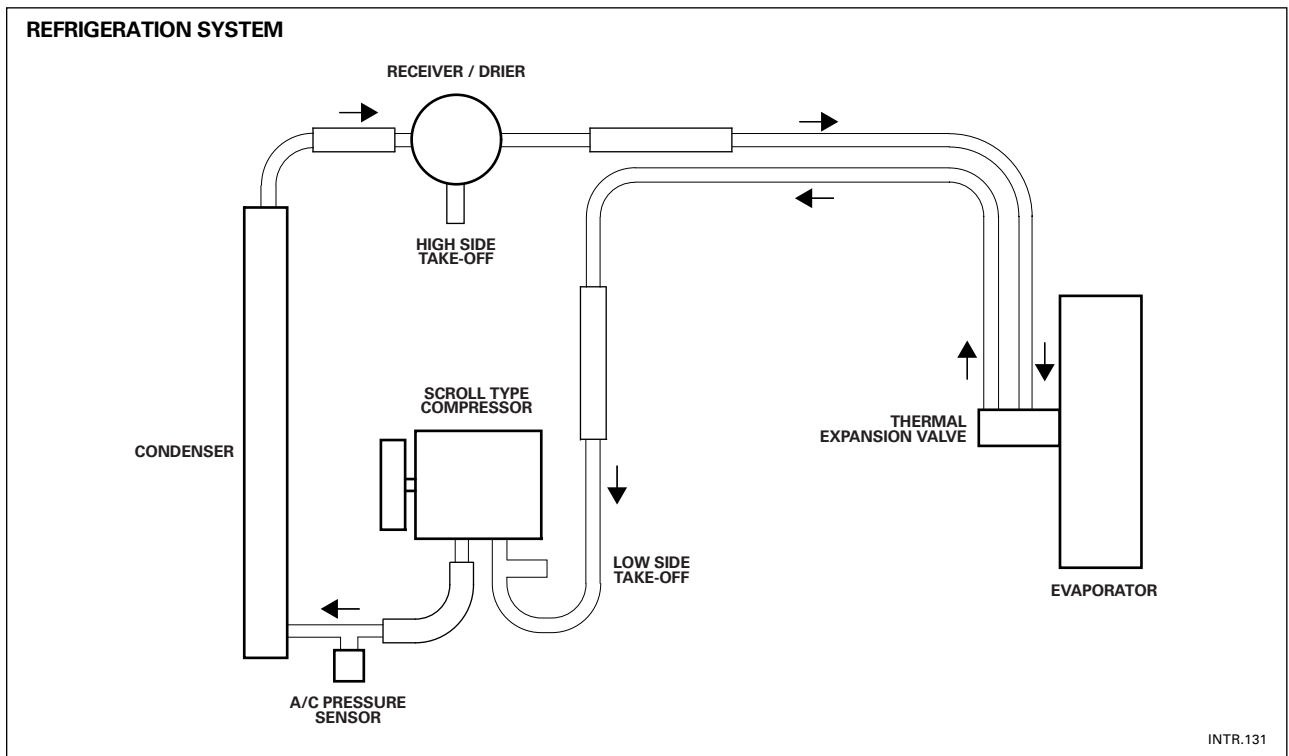

System Details

Dual Coolant Control Valve

The dual coolant control valve, located behind the right hand headlamp, contains two solenoid operated valves that are actuated by the A/CCM to achieve the driver and passenger selected temperatures. The A/CCM, using pulse width modulated (PWM) low (ground) side drives, positions the valves to control engine coolant flow through the partitioned dual zone (driver / passenger) heater core. Battery voltage (12 v minimum) is required to close the valves so that if electrical circuit failure occurs, the valves will remain open and allow full coolant flow to the heater core.

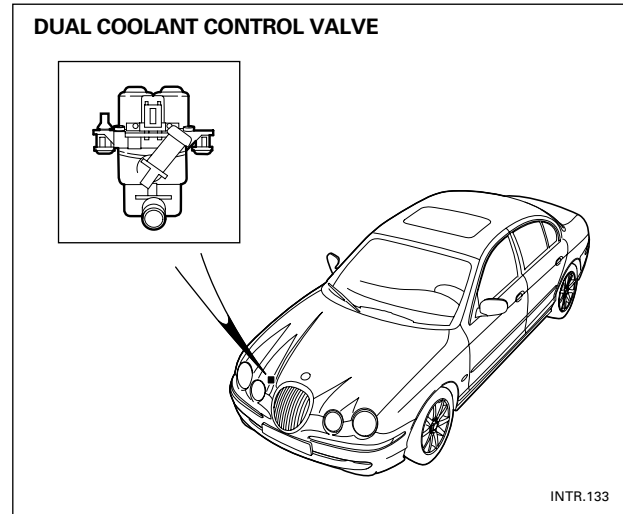

INTR.133

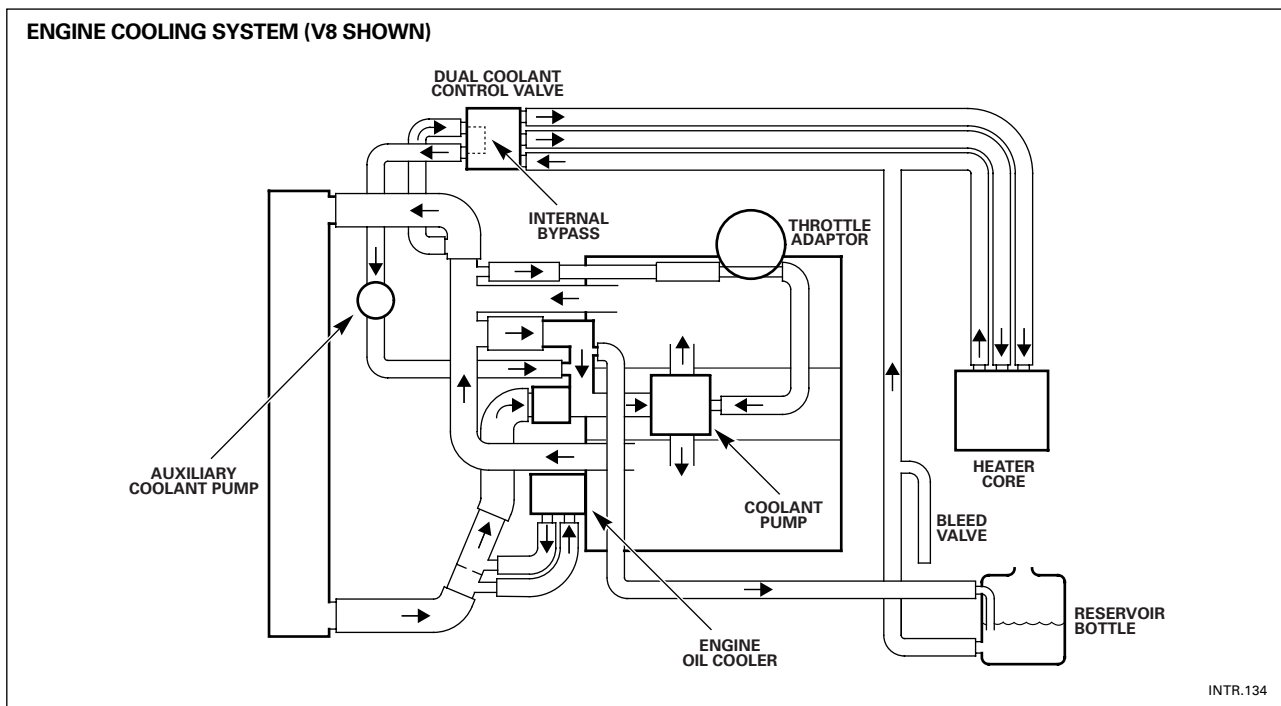

INTR.134

NOTES

DATC CLIMATE CONTROL

System Details (continued)

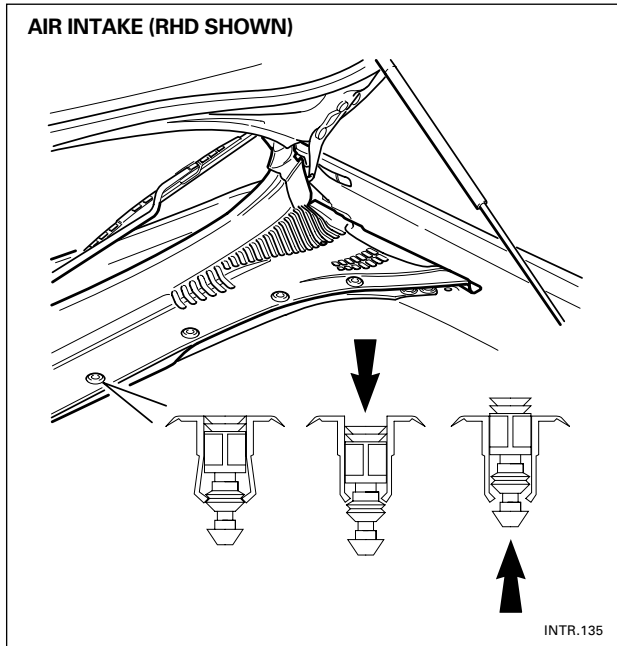

Climate Control Intake Air

Exterior air enters the system via the grille located at the base of the windshield on the passengers side of the vehicle. The grille can be removed by releasing the integral fasteners.

A serviceable air filter is located in the duct connecting the air intake to the blower housing. On NAS vehicles, the filter should be changed at the 10,000 mile service interval.

NOTES

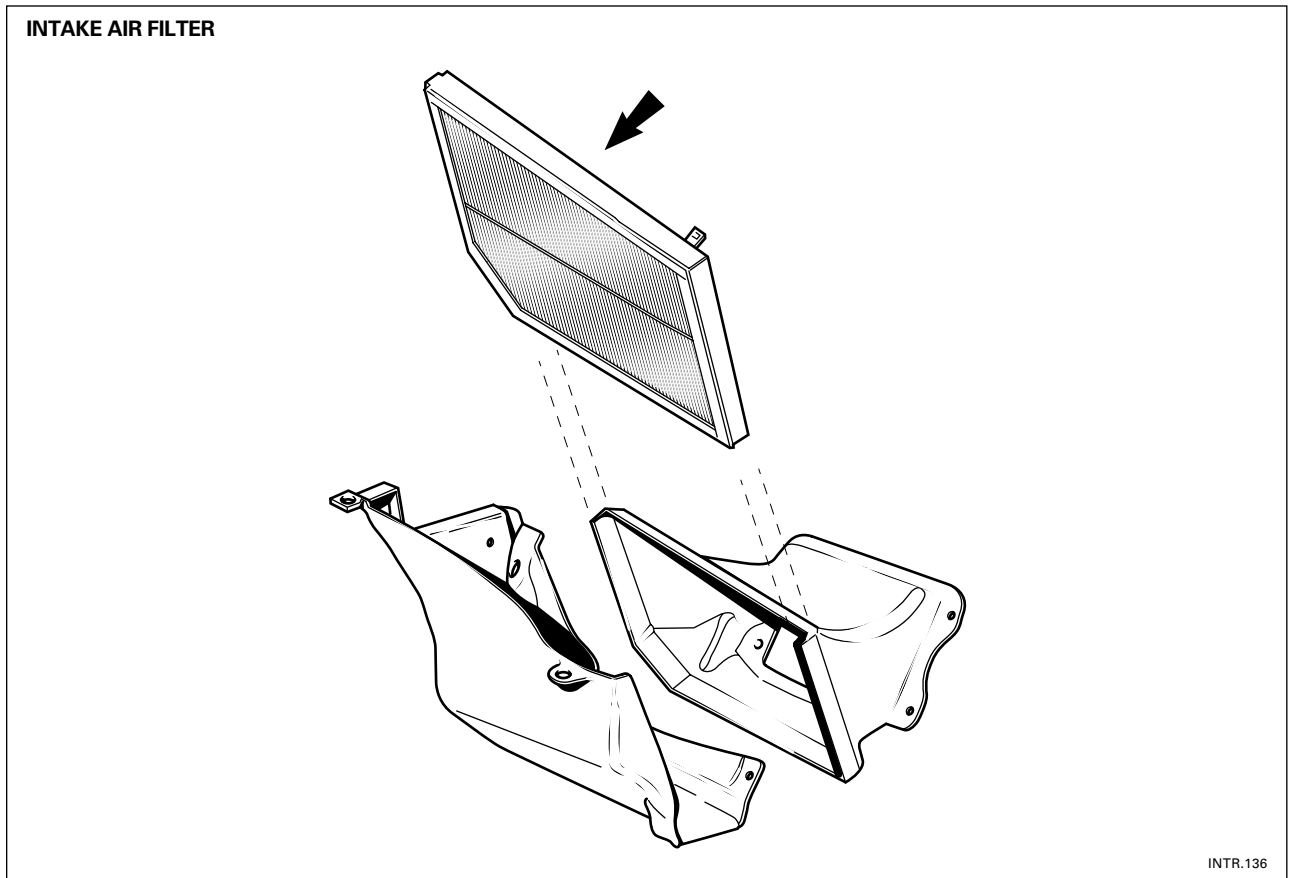

INTRODUCTION TO JAGUAR



1 INTRODUCTION TO XJ/XK

2 INTRODUCTION TO S-TYPE

- 2.1 Overview
- 2.2 Engine
- 2.3 PTEC Engine Management
- 2.4 Transmission
- 2.5 Suspension, Steering and Brakes
- 2.6 DATC Climate Control
- 2.7 Electrical Distribution System**
- 2.8 Body Systems
- 2.9 Occupant Protection
- 2.10 Task Sheets



ELECTRICAL DISTRIBUTION SYSTEM

Electrical System Architecture

The Jaguar S-TYPE electrical system is a supply-side switched system. The ignition switch directly carries much of the ignition switched power supply load. Power supply is provided via three methods: direct battery power supply, ignition switched power supply, and switched system power supply.

The switched system power supply is controlled via the GECM and the RECM from SCP messages. After ignition ON, four relays are activated by either the GECM or the RECM for as long as SCP messages remain on the SCP network. The relays will remain activated after ignition OFF, until all SCP messages are removed.

Engine management and transmission control are combined into a single Powertrain Control Module eliminating the need for a controller area network. The Jaguar S-TYPE employs an SCP network for all powertrain, chassis and body systems interface / control. An ACP network is employed for audio and communications systems interface / control.

Circuit ground connections are made at body studs located throughout the vehicle. There are no separate power and logic grounding systems.

The electrical harness incorporates hard-wired front and rear power distribution boxes and a serviceable primary junction box. All fuses and relays (except the trailer towing accessory kit) are located in the two power distribution boxes and the primary junction box.

NOTES

Power Distribution

Distribution cables supply battery power through to the starter motor and to three power distribution/fuse boxes. Harnesses distribute battery, auxiliary and ignition power from the fuse boxes to all the user components. The front power distribution/fuse box clean power is fed via a clean power 175 ampere fuse (megafuse) which is located next to the rear power distribution box/fusebox.

The secondary junction box is located on the bulkhead in the LH side of the cabin near the 'A' post. It acts as a splice header to avoid having numerous splices in the harness.

Battery

The low maintenance DIN 88, 90 ampere hour battery is installed on the RH side of the luggage compartment floor below the trim.

CAUTION: Sulfuric acid is highly corrosive. Batteries produce explosive gases. Keep flames and sparks away. Always wear protective clothing and face and eye protection to prevent injury while working around batteries.

NOTES

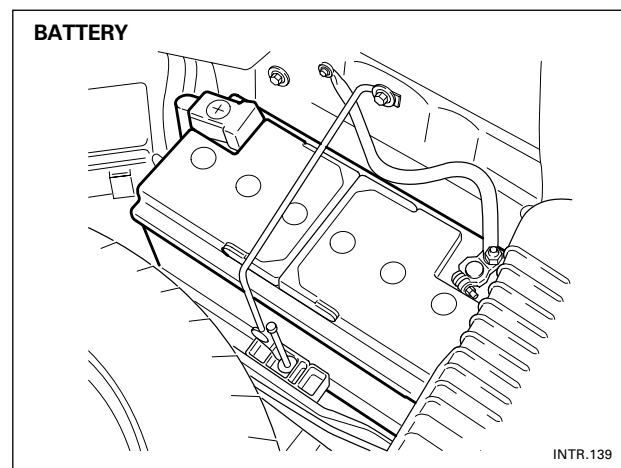
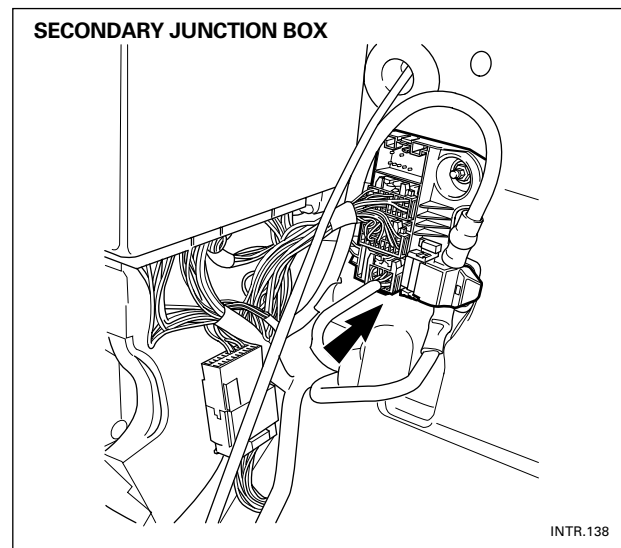
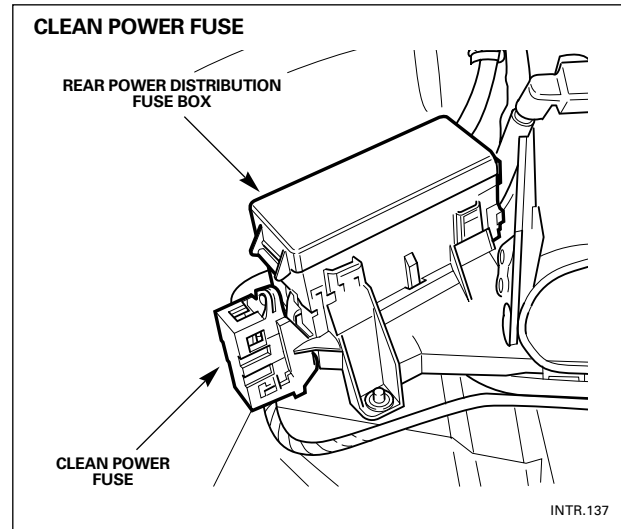

ELECTRICAL DISTRIBUTION SYSTEM

Fuses

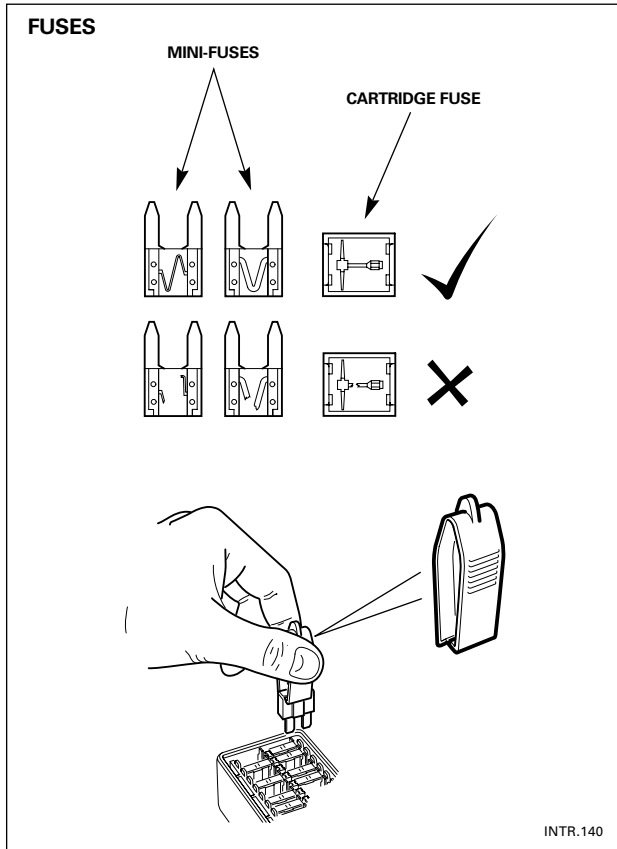

Fuse failure is identified by an inoperative circuit. Two types of fuses are fitted in the fuse boxes, a mini-type and a cartridge-type.

A special tool for removing and replacing the mini-fuse is provided in the passenger compartment fuse box, together with spare fuses. If a spare fuse is used, replace it with a Jaguar approved fuse of the same ampere rating.

Checking and Renewing a Blown Fuse

Make sure the new fuse is the correct rating (ampereage). Fuses are color coded according to the ampereage and the rating is also marked on each fuse.

WARNING: DO NOT FIT A FUSE OF A DIFFERENT AMPERAGE FROM THAT REMOVED. THE ELECTRICAL CIRCUITS MAY BECOME OVERLOADED WITH THE SUBSEQUENT POSSIBILITY OF A FIRE.

NO ATTEMPT SHOULD BE MADE TO REPAIR A FUSE THAT HAS BLOWN. THIS MAY CAUSE A FIRE HAZARD OR SERIOUS DAMAGE ELSEWHERE IN THE ELECTRICAL CIRCUIT.

NOTES

FUSE BOX LOCATIONS

FRONT POWER DISTRIBUTION FUSE BOX



PRIMARY JUNCTION FUSE BOX

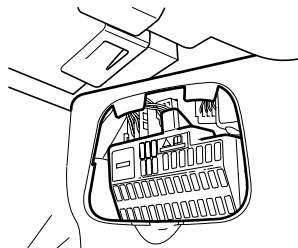

REAR POWER DISTRIBUTION FUSE BOX

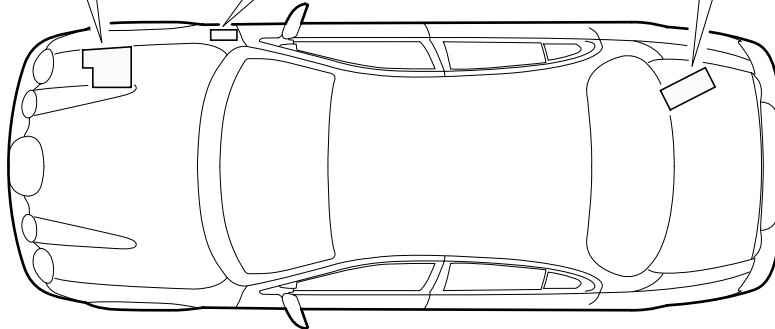
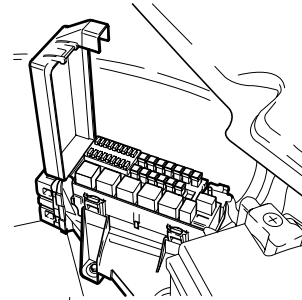

INTR.141

NOTES

ELECTRICAL DISTRIBUTION SYSTEM

Control Modules

The vehicle control module functions are described briefly below.

Anti Lock Brake/Traction Control and Dynamic Stability Control Control Modules (ABS/TCCM or DSCCM)

The anti-lock brake control module is connected to the SCP communication network. The module comes in two forms. The first type is the standard equipped anti-lock brake system (ABS) with traction control (TC). It controls the brake pressure to the four wheels to keep the vehicle under control while braking.

The second type of ABS is optional and is called dynamic stability control (DSC). This control module adds yaw sensors to the package to help in sensing a loss of vehicle control.

Audio Unit

The audio unit is connected to the SCP communication network and also to the audio control protocol (ACP) communication network. The audio control unit communicates with the compact disc and the cellular phone transceiver.

Driver Door Control Module (DDCM)

DDCM is connected to the SCP communication network. The module controls many functions including power windows, driver mirror, power locks, and keyless remote entry.

Driver Seat Control Module (DSCM)

The DSCM is connected to the SCP communication network. The DSCM is located under the driver seat and controls the seat positions. The module also communicates with DDCM to control the driver seat memory functions.

Air Conditioning Control Module (A/CCM)

The A/CCM is connected to the SCP communication network. The A/CCM controls automatic climate functions that maintain the vehicle at a constant temperature setting.

Instrument Cluster

The instrument cluster is connected to the SCP communication network. The instrument cluster displays information received on the SCP including speedometer, odometer, fuel, and message center warnings. The instrument cluster also controls the passive anti-theft system (PATS).

General Electronic Control Module (GECM)

The GECM is connected to the SCP communication network. This module is located behind the LH 'A' post trim panel below the fascia. The GECM controls many of the body systems, being directly linked to the interior lighting, wiper and security systems. It is a support module for other systems including exterior lighting, locking, remote entry, mirrors (passenger), seat/mirror/steering column memory recall and windows.

Rear Electronic Control Module (RECM)

The RECM is connected to the SCP communication network. This module is located in the passenger side luggage compartment behind the trim panel. The RECM controls the locking/unlocking of the front passenger and rear passenger doors and provides power control of the fuel pump.

NOTES

INTRODUCTION TO S-TYPE

Powertrain Control Module (PCM)

The PCM is connected to the SCP communication network. For the location of this module see the S-TYPE Powertrain Technical Guide. The PCM controls the engine performance, electronic ignition, emission controls, speed control, transmission and on board diagnostics.

Restraints Control Module (RCM)

The RCM is connected to the ISO 9141 communication network. The RCM controls the deployment of the air bags based on sensor inputs.

Vehicle Emergency Control Module (VECM)

The VECM is connected to the SCP communication network. The module allows a user to request emergency assistance (police, ambulance, fire, wrecker) or directions to a desired location at the touch of a button. Also, if any of the vehicle's airbags are deployed while the VEMS system is powered ON, the system automatically issues a call for emergency assistance.

Voice Activation Control Module (VACM)

The VACM is connected to the SCP communication network. This module is located in the driver side luggage compartment behind the trim panel. The VACM controls and processes all the voice commands given by the driver. It delivers this information to the audio unit, GSM or AMPS cellular phones and the A/CCM which then carry out these commands.

Control Module Configuration

Most S-TYPE control modules require configuration when replaced. Configuration sets up the control module to correctly function in the vehicle in which it is installed. If configuration is not carried out, one or more difficulties will occur:

- The engine will not start
- Incorrect operation may occur
- Certain features may not function

Configuration is performed using WDS and is carried out by performing the following steps:

- Select the "Vehicle Configuration" main tab
- Highlight "Configure New Modules"
- Select the appropriate module and follow on-screen prompts

NOTES

ELECTRICAL DISTRIBUTION SYSTEM

Control Modules (continued)

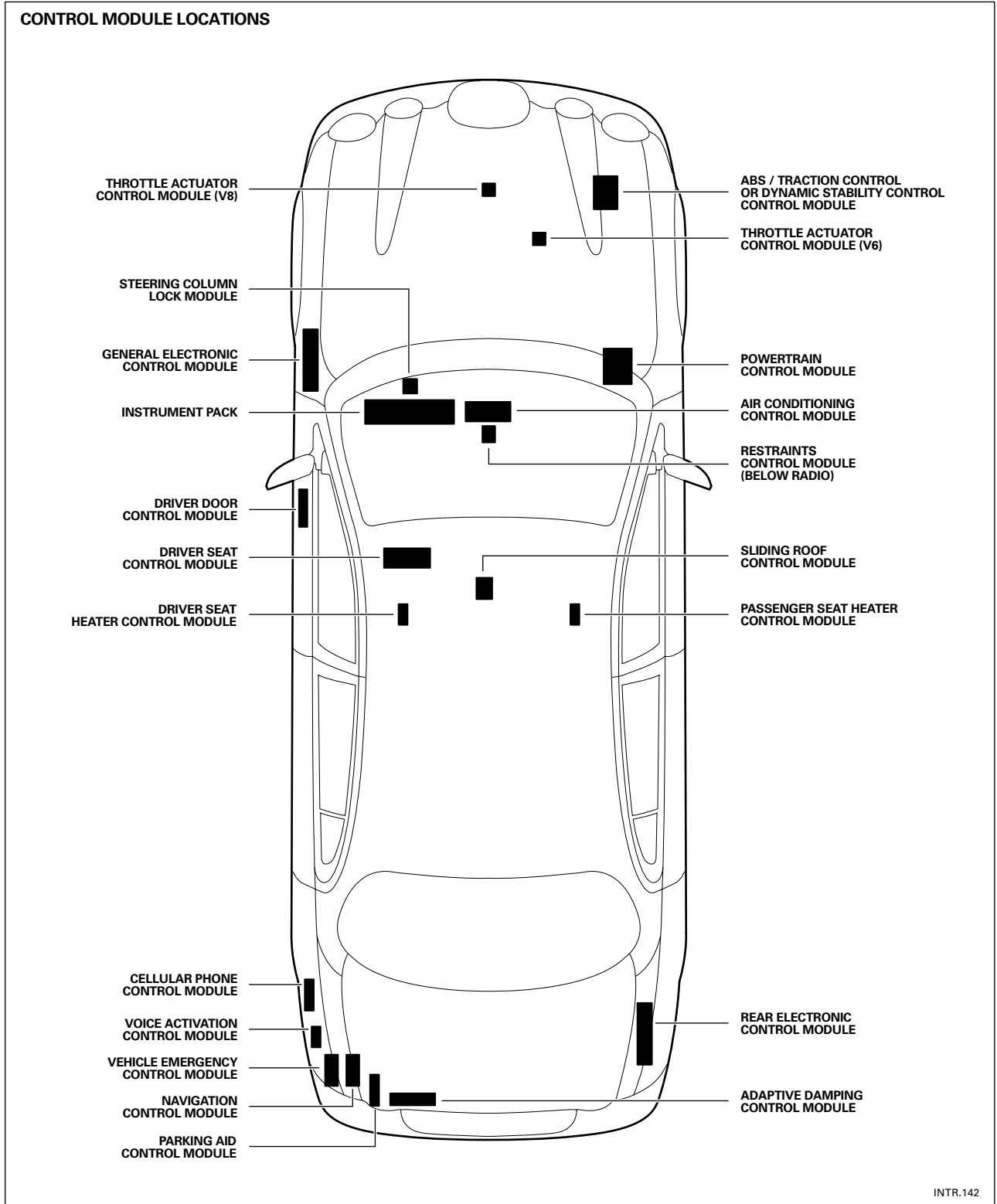

Networks

The S-TYPE has three module communications networks. The first is the Standard Corporate Protocol (SCP) Network (J1850 SAE Standard), which is a twisted pair of cables: data bus plus and data bus minus. The second is the Serial Data Link (ISO 9141), which is a single wire network. The third is the Audio Control Protocol (ACP) Network, which, like the SCP, uses a twisted pair of wires. ACP is used only for the audio system. Both the SCP Network and the Serial Data Link can be connected to WDS by the data link connector (DLC), located under the instrument panel between the steering column and the audio unit.

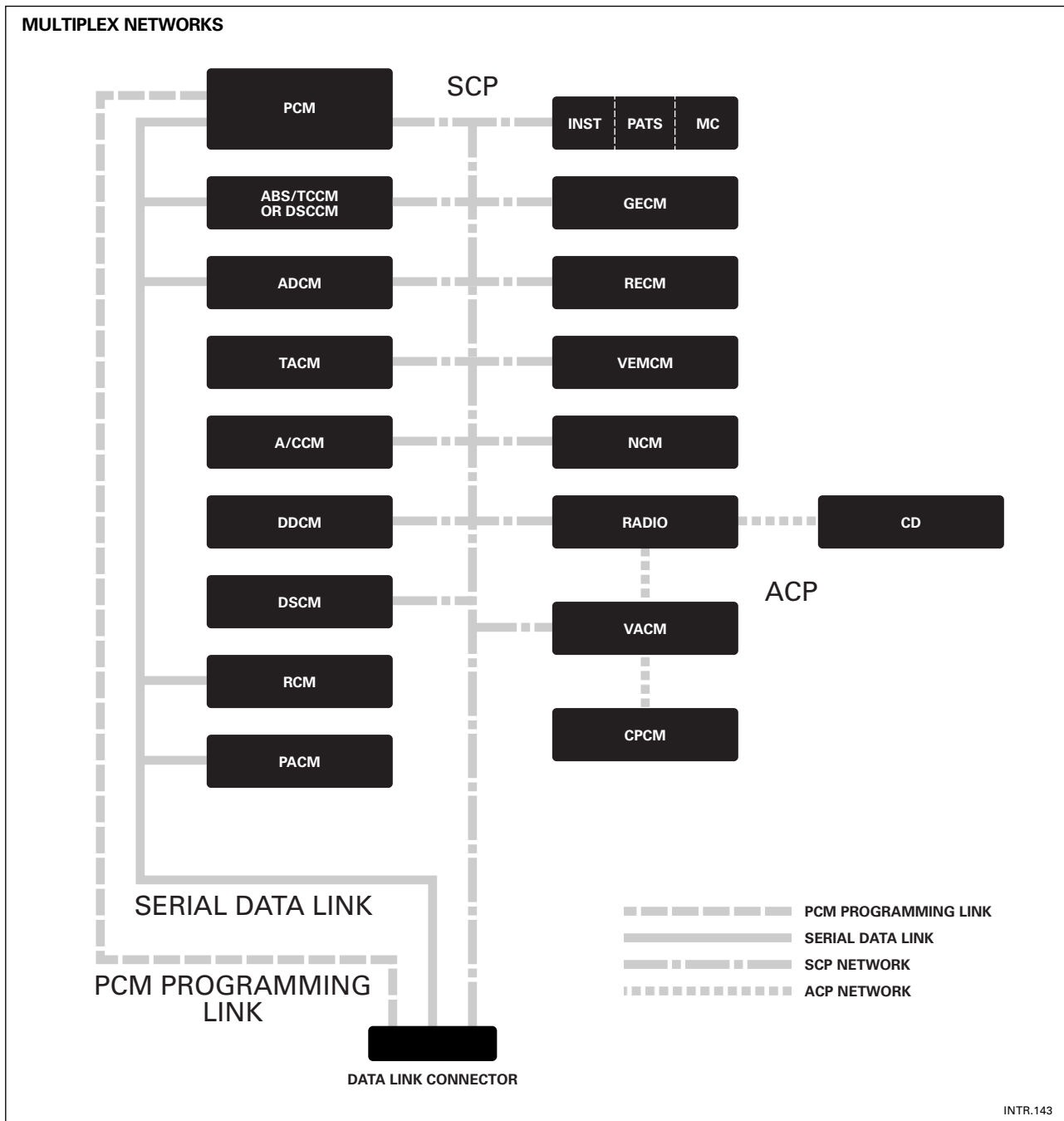

INTRODUCTION TO JAGUAR



1 INTRODUCTION TO XJ/XK

2 INTRODUCTION TO S-TYPE

- 2.1 Overview
- 2.2 Engine
- 2.3 PTEC Engine Management
- 2.4 Transmission
- 2.5 Suspension, Steering and Brakes
- 2.6 DATC Climate Control
- 2.7 Electrical Distribution System

2.8 Body Systems

- 2.9 Occupant Protection
- 2.10 Task Sheets



BODY SYSTEMS

Exterior Lighting

Exterior Lighting Switch

Autolamps Delayed Exit (A)

This feature leaves the headlamps turned on after the ignition has been switched off, allowing the driver and passengers increased visibility on leaving the vehicle. The switch has seven positions and varies the time from three seconds up to three minutes. After adjustment, the newly set delay time will be displayed on the message center.

Auto (B)

A light sensor on top of the instrument panel, monitors exterior light levels and automatically switches the sidelamps and dipped headlamps on or off. When light fades to the non-adjustable preset level, the sidelamps and headlamps switch on automatically. As light increases to the preset level, the sidelights and headlamps switch off automatically.

Rear Fog Lamps (F)

Turn the switch to headlamps on, pull the switch and then turn to position (F). Turning on the rear fog lamps will also turn on the front headlamps.

Front Fog Lamps (G)

Pull the switch in positions (A), (B), (D) or (E) to switch on the front fog lamps. Push to turn off. If the rotary switch is turned to off (C) the switch will be retracted to its normal position and the fog lamps will be turned off.

Daytime Running Lamps

In certain countries it is a legal requirement for the lamps to be on during the hours of daylight. With the rotary switch in the off position (C), dipped headlamps, sidelights and tail and number plate lamps will switch on automatically when the ignition is turned to position II, the vehicle is out of park (automatic transmission only) and the parking brake is released.

Battery Saver

If the dipped or main beam headlamps are switched on and the ignition is turned to OFF or the key is removed, the lamps will automatically turn OFF after 10 minutes. The sidelights will remain ON.

Bulb Failure Monitoring

The tail and brake lamp bulbs are monitored for failure and a corresponding message is shown in the message center, e.g. 'LEFT TAIL LAMP FAILED'. There are two tail lamp bulbs in each tail lamp. The message that a tail lamp has failed indicates that both bulbs in that cluster have failed. The message will be shown, even after a bulb is replaced, until the next time the bulb is switched on.

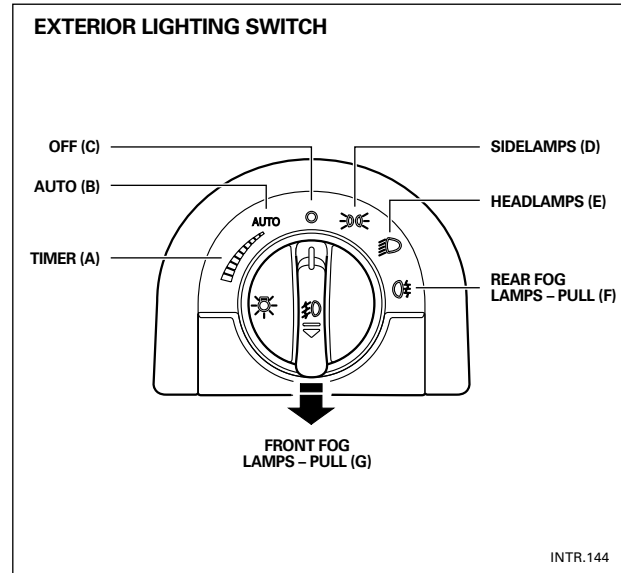

NOTES

BODY SYSTEMS

Exterior Lighting (continued)

Headlamp Assembly

The bulbs are halogen type and will be damaged if touched by hand or contaminated with oil or grease. It is important to use clean gloves or cloth when handling a bulb which is to be used again. A contaminated bulb may be cleaned with methylated spirit before refitting.

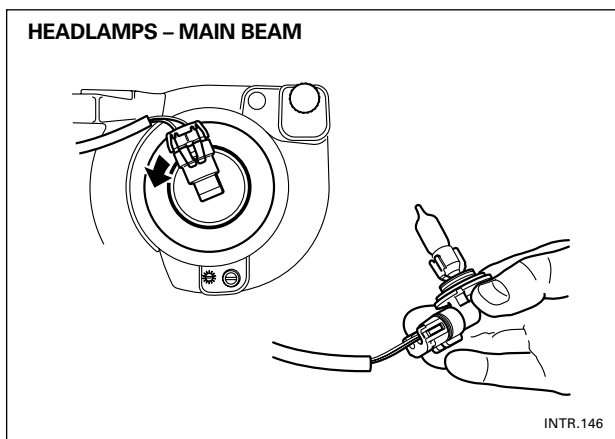
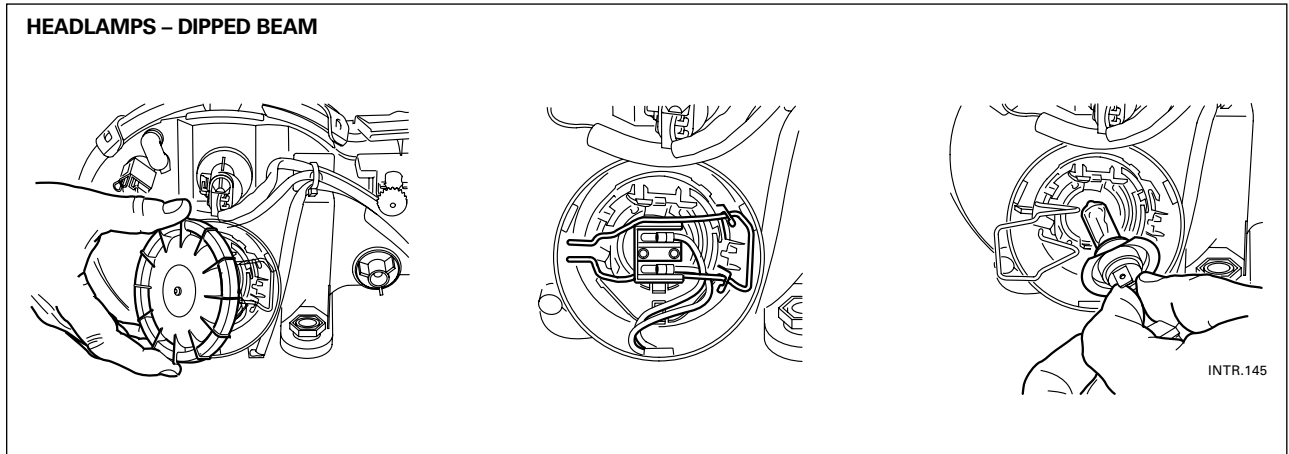

The headlamp assembly contains the following bulbs:

- Dipped Beam (outer) headlamp – type H7
- Main Beam (inner) headlamp – type HB3
- Front Turn Signal lamp – type PY21W
- Front Parking (side) lamp – type W5W

To remove any of the above bulbs, the top cover has to be removed first.

NOTES

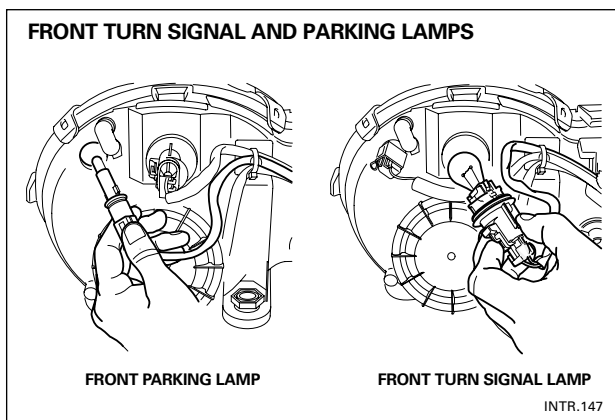

Front Fog Lamp

Remove bumper splitter vane and blackout panel. Unscrew fixing; remove lamp from front. Twist/remove bulb carrier. Remove the bulb and fit a new one of the correct type (H3).

Side Repeater Indicator

Remove the lamp unit from the front wing panel by pressing the unit forwards or rearwards to compress the spring clip and remove the complete unit. Twist the bulb anti-clockwise and remove. Fit a new bulb of the correct type (WSW). Press the unit into the recess until it clicks into place.

Rear Lamp Assembly

The rear lamp assembly has the following bulbs:

- Reverse lamp, type P21W
- Stop/tail lamp, type P21/4W
- Fog lamp, type P21W
- Tail lamp, type R5W
- Turn signal, type PY21W

Open the luggage compartment, loose the side carpet and unclip the rear lamp bulb carrier.

Remove the faulty bulb and fit a new one of the correct type, as illustrated on the bulb holder. Fitment of the correct type is essential.

NOTES

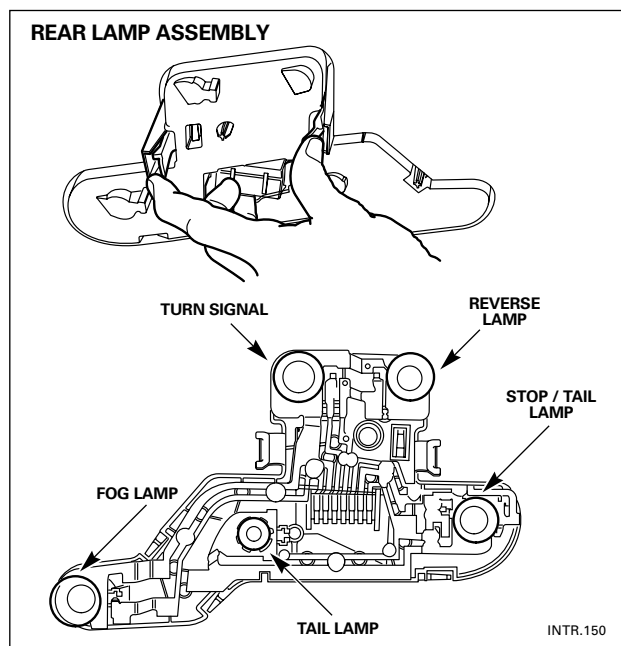
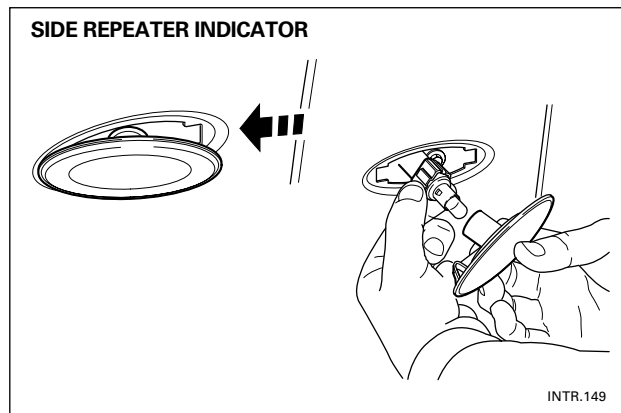
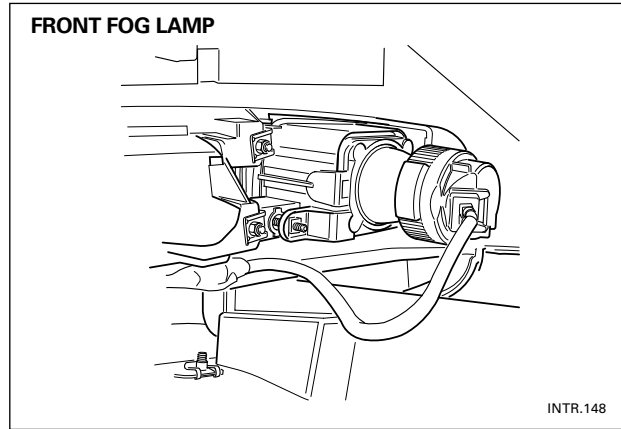

BODY SYSTEMS

Interior Rear View Mirror

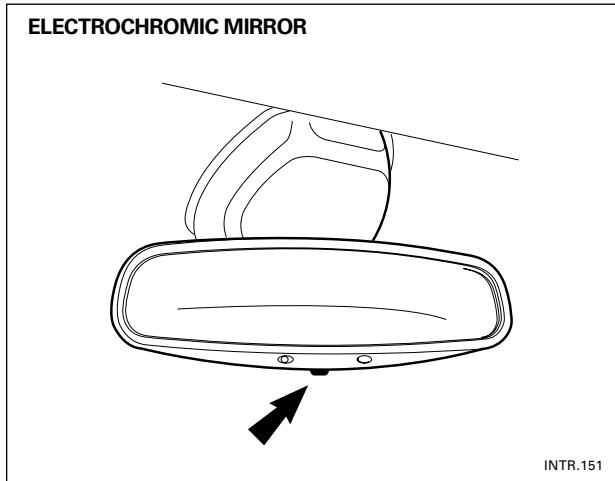

There are five derivatives of interior rear view mirror:

- Base, non-electric
- Electrochromic
- Electrochromic with rain sensing
- Electrochromic with compass
- Electrochromic with rain sensing and compass

Electrochromic Interior Rear View Mirror (where fitted)

Push the switch in and the rear view mirror darkens automatically to prevent glare from the following vehicle's headlamps. The mirror clears when the light levels return to normal. The mirror also clears when reverse gear is selected. Where fitted, an LED is lit when mirror dimming is active. Push the switch again and the glare-reducing effect of the mirror is switched off so that a clear reflection is given.

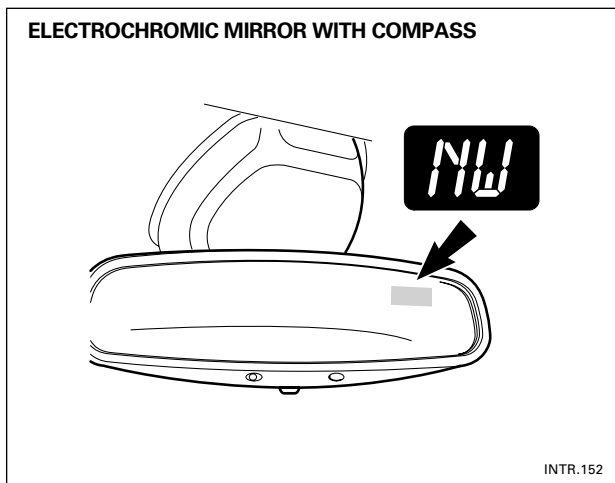

Electrochromic Interior Rear View Mirror with Rain Sensing (where fitted)

The moisture sensor for the wipers is fitted to the windshield and covered by the mirror pod.

NOTE: The auto headlamp sensor is fitted to the fascia for the S-TYPE, not to the mirror as on XJ.

Ensure that the windshield in front of the mirror pod and the autoheadlamp sensor is kept clean since any dirt may affect the operation of these sensors.

NOTES

Electrochromic Interior Rear View Mirror with Compass

The compass direction is given in a digital display (eight compass points) in the corner of the mirror. The brightness of the compass display dims as the ambient light level falls. The compass must be calibrated by the Dealer at PDI to compensate for the difference between magnetic north and the true north in the part of the world where the car is driven. For best results, the calibration procedure should take place in an open area free from overhead power lines or large metal structures.

On the underside of the mirror pod there are two small holes. Insert a small screwdriver or other pointed tool into the RH hole. Press the button in the hole until the word 'ZONE' appears in the display. Continue to press to select a number corresponding to the zone shown in the diagram for the area in the world where the vehicle is driven.

Press the button in the LH hole until the 'CAL' indicator appears in the display. Slowly drive the vehicle in a circle until the 'CAL' indicator disappears. This should happen after two or three revolutions. The compass is now adjusted to compensate for the vehicle's magnetic field.

NOTE: Using the vehicle in the vicinity of CB radios or an airport may cause the display to extinguish for a few seconds.

NOTES

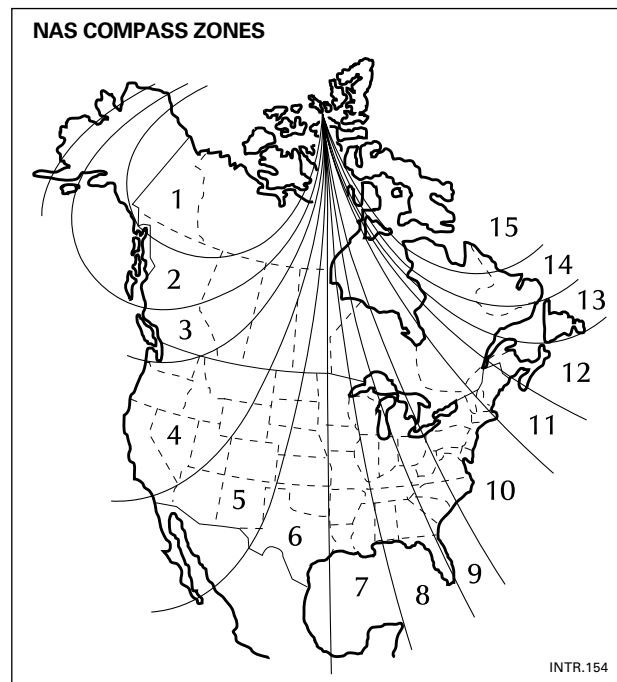
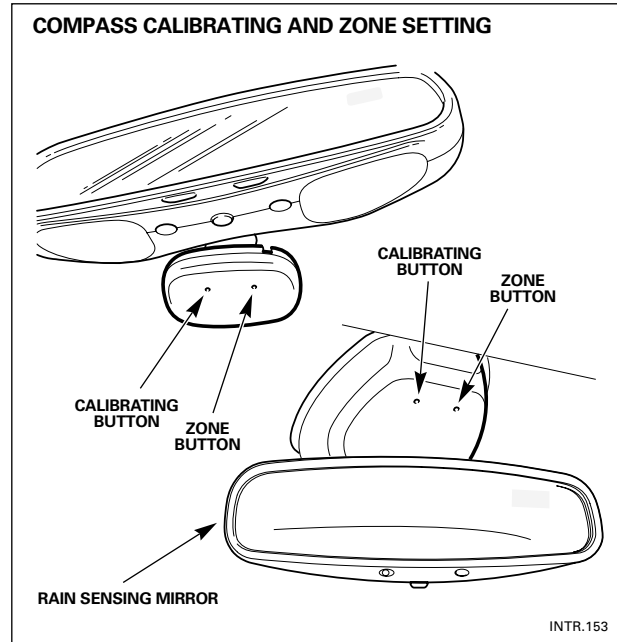

BODY SYSTEMS

Security and Locking Systems

The following security and locking features are available but vary by market or options:

- Key barrel on driver's side only
- Encrypted engine immobilization by ignition key transponder (PATS)
- Radio frequency remote fob
- Central locking by key and remote fob
- Drive away door locking
- Mechanical child locks on rear doors
- Perimeter alarm of doors, bonnet, trunk
- Inclination (tilt) sensing (Dealer fit accessory)
- Panic alarm, fob operated
- Trunk lock isolate

The following convenience features are included either as standard or optional features:

- Remote fob operated driver's seat, door mirrors and steering column memory recall (two memories)
- Remote fob operated trunk lid release
- Key operated global close (sliding roof and all windows)
- Key and fob remote-operated global open (sliding roof and all windows)
- Trunk lid and fuel flap interior release buttons
- Trunk release button in trunk plinth
- Emergency key lock barrel under trunk plinth

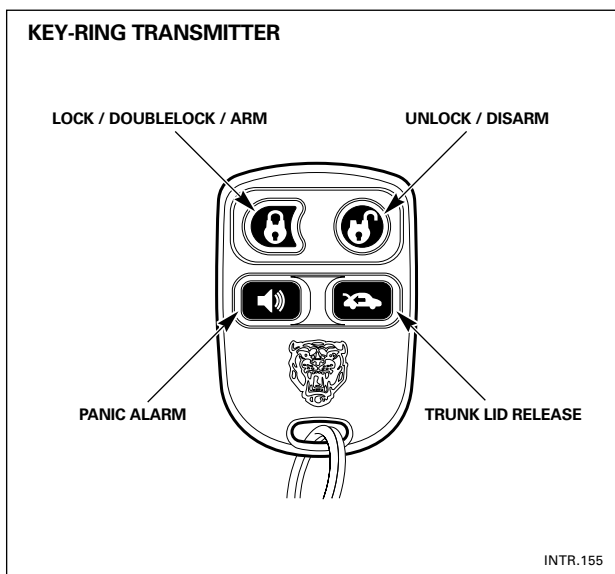

System Description

The security system is controlled by a driver door control module (DDCM). When activated unauthorized entry into the vehicle is detected by the courtesy lamp switches. When the alarm is triggered, the system flashes the turn signal lamps and sounds the alarm system horns.

Key-ring Transmitters

The security system is controlled remotely by a radio frequency, battery-operated transmitter. The transmitter is activated by pointing it towards the vehicle and pressing one of the operating buttons.

Key-ring transmitters will not operate if a key is in the ignition switch.

Two transmitters are supplied with the vehicle, but up to four can be used provided they are all programmed to the vehicle by the Dealer.

Keys

Two black-headed keys (and one green-headed key in the North American market) are supplied with the vehicle. The key number is recorded on a plastic tag which is attached to each key.

Each black-headed key will operate the ignition switch and lock the doors, luggage compartment and the glove box. The green-headed key is a valet key which will not unlock a locked glove box or locked trunk lid. The interior and exterior trunk switches will not unlock the trunk lid when the valet switch has been set.

An electronic device is fitted in the head of each key which is programmed to the vehicle electronics. When the key is placed in the ignition switch the vehicle electronics recognize the correct key and allow engine start. The engine cannot be started with a key not programmed to the vehicle electronic systems.

Up to eight keys can be used provided the Dealer programs them all to the vehicle.

NOTES

ANTI-THEFT SYSTEM COMPONENTS

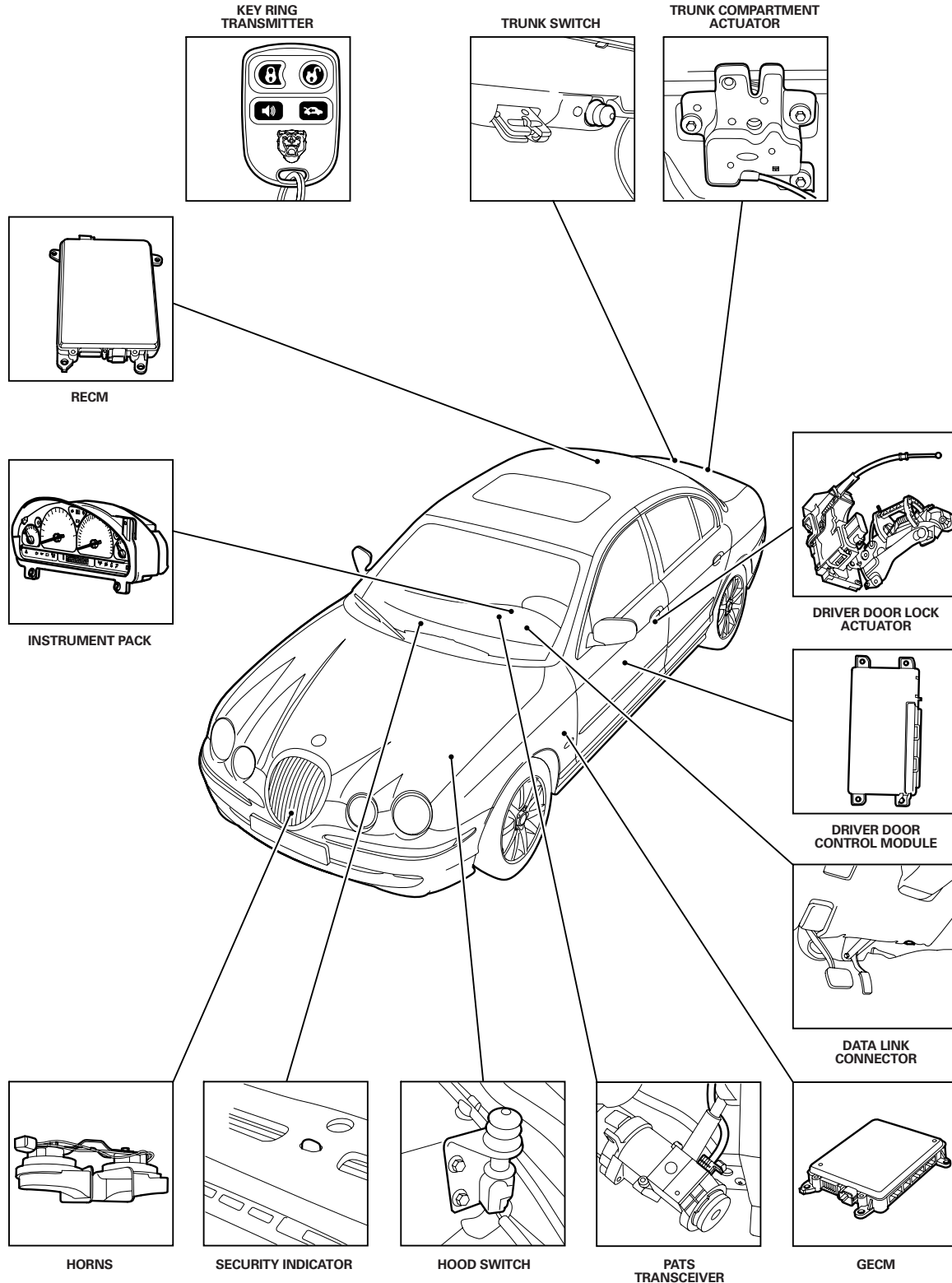

INTR.156

BODY SYSTEMS

Security and Locking Systems (continued)

Passive Anti-Theft System (PATS)

The Passive Anti-Theft System (PATS) function is split between the instrument pack and the PCM. In order for the engine to crank and start, the instrument pack must have read a valid ignition key code, and the correct information flow must have occurred between the instrument pack and the PCM. Correct PATS operation can be determined by observing the security LED indicator “flash code”. The security indicator, situated on top of the fascia, will also flash fault code information.

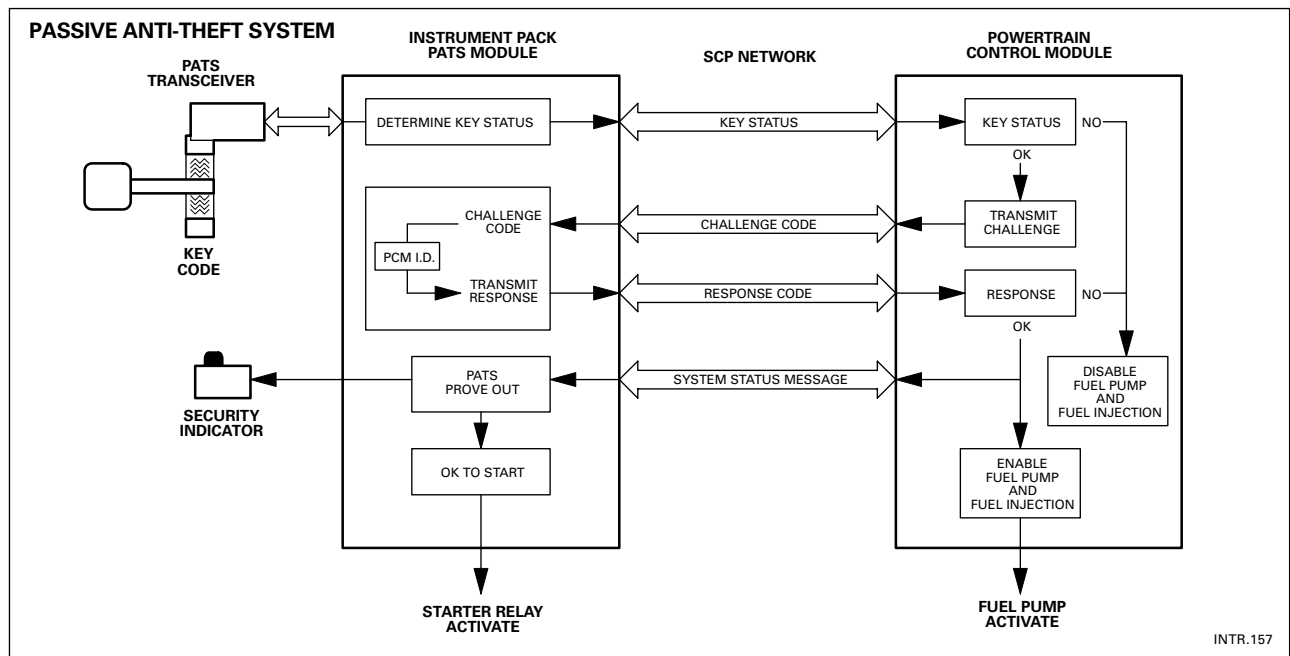

PATS Operation

When the driver inserts the ignition key into the ignition switch key barrel, the Key-In switch closes and applies B+ voltage to the instrument pack. This signal causes the instrument pack to read the PATS key transponder code stored in the ignition key and compare it with those stored in memory.

The result of this comparison is transmitted to the PCM via the SCP network. If the key code is OK, the PCM will send a challenge code to the instrument pack. If the correct response to the challenge code is received within one second, the PCM will enable fuel pump operation and fuel injection. Simultaneous with the PCM challenge, if the key code is OK, the instrument pack will complete the starter relay coil circuit to ground when the ignition switch is moved to position III (START).

The PCM will not enable fuel pump operation or fuel injection if any of the following conditions exist:

- The ignition key code is not recognized (theft signal).
- A response to a challenge code has not been received within one second.
- An incorrect response to a challenge code has been received.

NOTES

PATS Diagnostics

Correct PATS operation can be confirmed by observing the security indicator as the ignition key is inserted. The LED should illuminate for 3 seconds when the key is inserted and moved to position II (RUN), then switched OFF. This action will validate all PATS functions:

- The key transponder code matches the key code stored in memory.
- The challenge / response sequence between the instrument pack and the PCM has been successful.
- The fuel pump and fuel injection have been enabled.

Normal PATS communications are completed within 1.4 seconds after key-in or the ignition switch transition from 0 to II or III. If PCM communication problems exist, the time duration can be as long as 2 – 3 seconds and still provide a functional prove out.

If PATS faults are detected during the maximum 3 second period and a valid ignition key has been used, the security indicator will exit its prove out mode and start to flash. When the ignition key is moved to 0 (OFF), the flashing will terminate and control of the security indicator will shift to the vehicle security system.

PATS Faults

If a PATS fault is detected, the security indicator LED will flash for 60 seconds at 4 Hz with a 50% duty cycle. At the end of this period, the LED will flash a two digit flash code, repeated 10 times. As a general rule, flash codes numbered 15 or less will prevent engine cranking while codes numbered 16 and above result in the engine cranking but not starting (fuel pump and fuel injection disabled).

PATS Diagnostics Summary

Mode of Operation / Fault	When logged	Ignition Switch position	DTC	Flash Code
Prove-out	n/a	0 (OFF) to II (RUN) / III (START)	n/a	3 seconds – on
Perimeter theft control	n/a	0 (OFF)	n/a	Steady flashing
Anti-scan – Incode	Security access	II (RUN) / III (START)	n/a	None
Transceiver not connected / open circuit (no diagnostic byte received)	Key read	II (RUN) / III (START)	B1681	11
Corrupted diagnostic byte received from transceiver	Key read	II (RUN) / III (START)	B2103	12
Ignition key transponder signal not received	Key read	II (RUN) / III (START)	B1600	13
Ignition key transponder signal invalid	Key read	II (RUN) / III (START)	B1602	14
Ignition key code incorrect	Key read / diagnostic test	II (RUN) / III (START)	B1601	15
SCP Network fault: PCM verify does not match key status	PCM/SCP communications	II (RUN) / III (START)	U1147	16
SCP Network fault: security system status message missing	PCM/SCP communications	II (RUN) / III (START)	U1262	16
Less than 2 keys programmed	Before & after / dealer	II (RUN) / III (START)	B1213	21
PCM ID not in instrument pack non-volatile memory	Before & after / dealer	II (RUN) / III (START)	B2141	22
PCM ID does not match instrument pack	Challenge / response	II (RUN) / III (START)	B2139	23
Transponder programming failure	Key prog.	II (RUN) / III (START)	B2431	13

BODY SYSTEMS

In-Car Entertainment (ICE)

The Jaguar sound system is available in two versions: the Base System and the Premium System. The audio unit with integral amplifier is located in the center stack. The audio system has a phone interface to access stored numbers. The antenna module is located on the vertical panel under the rear parcel shelf (accessed from the LHS of the trunk), FM and AM antenna elements are in the rear screen. Four twin cone 5in. x 7in. door speakers are a modular cassette type for ease of assembly/disassembly. The assembly consists of a driver's door module (driver's door only), speaker, and wiring and is mounted to the inner door molding. A special seal is kept under tension to avoid water ingress.

The system is operated by the controls on the fascia panel and the controls on the LH side of the multi-function steering wheel (where fitted).

The radio has an alpha-numeric display which shows information such as station frequency, program service name, tape & track, CD and track, phone mode and audio mute. Steering wheel switch commands however, (when the steering wheel switches are pressed) are shown on the Instrument Pack message center.

The radio incorporates communication links with Jaguar unique features: CD Autochanger, Cellular Phone, Voice Activation and Navigation system. Text messages relating to these features appear on the display.

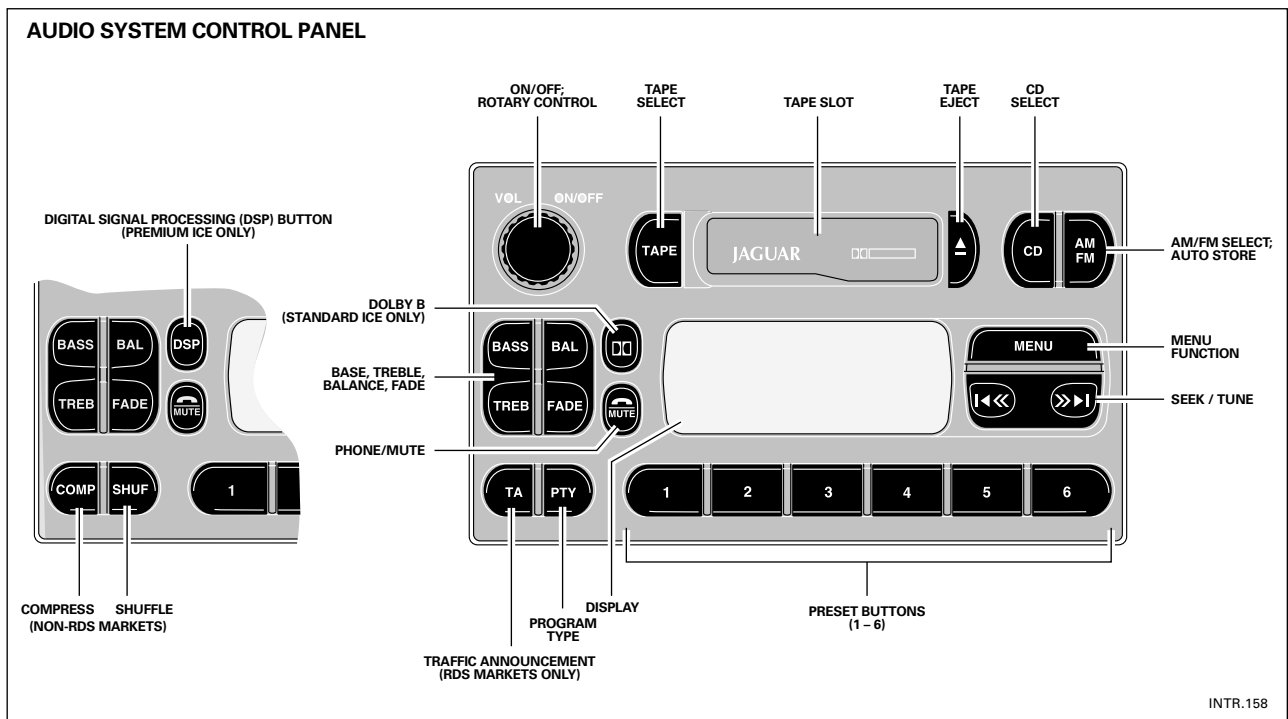

NOTES

Menu

Press the menu button repeatedly to cycle through the first level menu functions; press the seek button to enable/adjust the selected item. The extended menu features can be accessed by depressing and holding the menu button for two seconds. Use the seek button to enable/adjust the selected item. Some functions in the menu structure require the use of the volume control.

First Level Menu

Button Press	Radio	Tape	CD
1	MAN – manual tune	DOLBY ON / OFF	SHUF – shuffle
2	AVC – automatic volume control	AVC	COMP – compress
3	*NEWS ON / OFF	*NEWS ON / OFF	AVC
4			*NEWS ON / OFF

* The NEWS enable/disable function is only available in MENU when the radio is in FM mode.

Second Level (Extended Menu)

Button Press	Function
1	ADJUST CLOCK (hours) – adjust
2	ADJUST CLOCK (minutes) – adjust
3	12 / 24 HR CLOCK – adjust
4	RDS TIME ON / OFF
5	VOICETRAIN A (when fitted)
6	VOICETRAIN B (when fitted)
7	Vehicle Identification Number (VIN)

Security Code

The unit is protected by an anti-theft security code. Any power interruption will cause the display to indicate 'CODE'. At this point the unit will not operate until the correct security code has been entered. The four digit security code is listed on the two security cards supplied with the vehicle. After three unsuccessful attempts, the unit will not accept further entries until a delay of 30 minutes has elapsed. Up to seven further attempts may be made, with a delay of 30 minutes between each, after which the display will show 'LOCKED'.

If the security code is lost or the display shows 'locked' the owner will need to return the vehicle to the Dealer. The Dealer must ask for proof of ownership and the serial number of the unit before supplying a security code given by contacting Jaguar Cars Ltd. To display the serial number, press and hold preset buttons two and six simultaneously.

The remaining controls are similar to those in previous Jaguar audio systems. For specific operation of all the controls refer to the owner's Audio Systems Handbook.

NOTES

BODY SYSTEMS

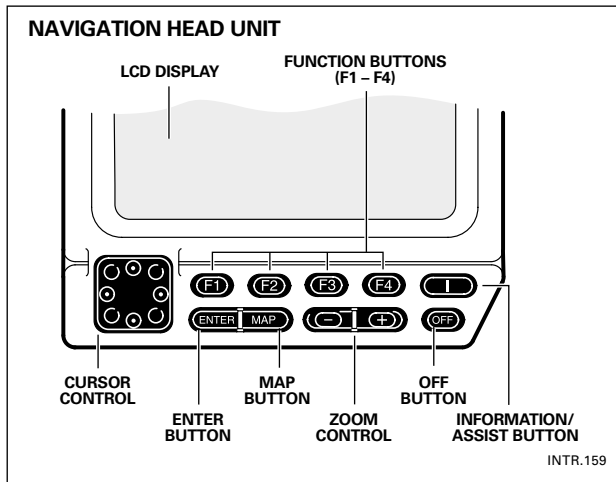

Navigation System

The Jaguar Navigation system assists the driver by providing a route to a selected destination. The navigation head unit, comprising a 5 inch (130 mm) full color screen and the control switch assembly is designed as an integral unit of the center stack. The navigation control module/CD map loader is mounted in the rear LH side of the trunk and covered by a dedicated styled trim panel. The GPS antenna is located above the rear parcel shelf but hidden underneath the interior trim. Digital map information is held on a compact disk (CD) which is loaded into the navigation control module.

The LCD provides full information for operating the system by means of menus, text prompts and map displays. Screen selections are made by the controls on the front panel.

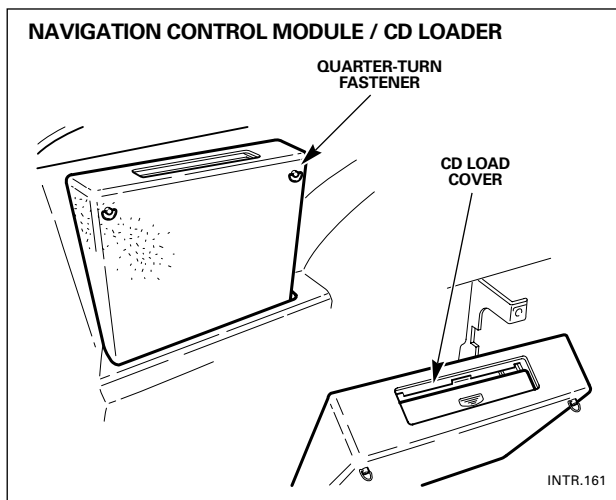

System Operation

The system uses signals from the Global Positioning System (GPS) satellites, which enables the Navigation control module to calculate, with the aid of CD ROM map data, ABS sensors' signals and Gyro sensor's signals, the exact position of the vehicle to within meters. After entering the desired destination, the driver is guided along by both voice and visual instructions. If the driver strays off the route, the system calculates a new route showing the easiest way back to the original destination.

Voice Guidance

A chime and an audible instruction will be heard just before the vehicle reaches the next junction along the route where a turn has to be made.

Screen Guidance

The screen shows the map display with the current vehicle position and route highlighted. Just before each turn, the screen automatically shows the next junction diagram (with turn information) overlaid on the map display. After the junction, the screen returns to full map display.

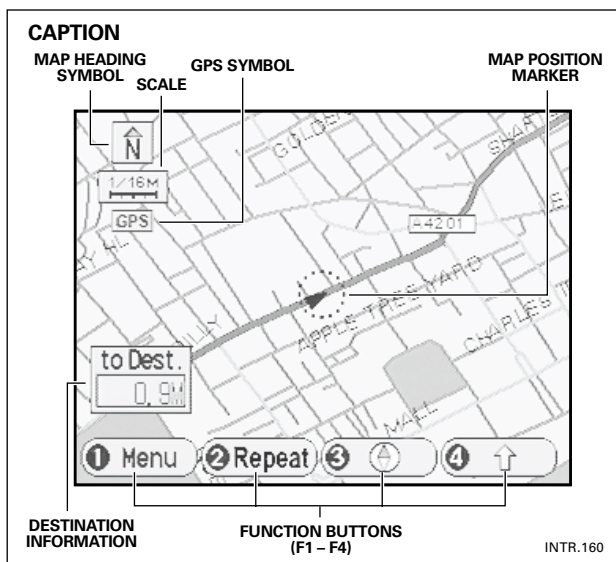

Jaguar Assist (NAS only)

Assist is an integrated vehicle emergency message system (VEMS) that uses the Jaguar security response center for emergency roadside assistance via the Jaguar in-car telephone installation. The global positioning system (GPS) is used to identify the position, direction of travel and speed of the vehicle. Access to the Assist feature is through the use of the Navigation system. The emergency assistance feature allows rapid access to the emergency services (police, fire or ambulance) and roadside assistance. Once assistance has been requested and the vehicle location confirmed, the appropriate services are contacted for assistance to be dispatched. In the unfortunate event of an air-bag deployment, the system will automatically place an emergency call.

Access to the system is gained by pressing the information button on the Navigation front panel screen (the ignition must be in position I or II). While in use, a sequence of messages is displayed on the LCD.

NOTE: If an Assist call is initiated and the operator cannot establish voice communication, police assistance will be dispatched to the vehicle.

The system can be used wherever a cellular phone service is available. The Jaguar phone must be connected to the vehicle, working correctly and registered with a cellular network. A roaming airtime agreement is required so that the system can be used in all areas.

Diagnostic Light

A diagnostic light is integrated into the information (ASSIST) button. The diagnostic light flashes throughout an activation but stays on continuously when a failure is detected. A message is given on the display: 'ASSIST FAILURE'. There are four potential failure modes:

- No VEMS menu is displayed when the information ASSIST button is pressed
- No activation is performed when the enter button is pressed to make a selection
- VEMS is unable to compute the location of the vehicle's current position
- The Navigation system is unable to display any VEMS messages or would display the wrong VEMS messages.

NOTES

BODY SYSTEMS

Voice Activation

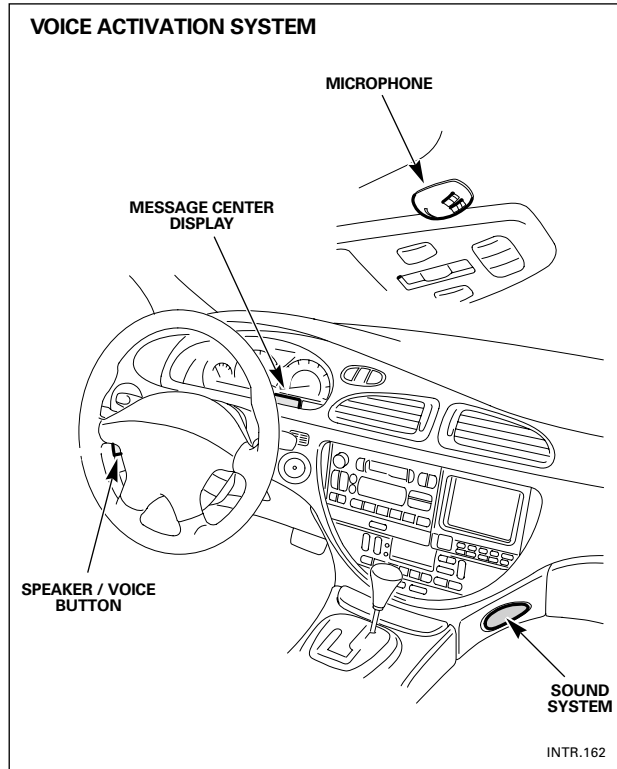

Voice Activation, currently available in a limited number of markets, provides a convenient way of controlling the following vehicle systems (where fitted):

- Sound System (radio, cassette tape player and CD player)
- In-car Telephone
- Climate Control System

The system is controlled by the Voice button on the left-hand side of the steering wheel. Voice commands are picked up by a directional microphone mounted on the headlining between the overhead console and the sunvisor. The microphone is also used for the in-car telephone. When giving a command, audible feedback will be heard through the sound system speakers and messages will be shown on the message center display. Audible feedback can be turned off if required. The system is capable of storing unique nametags for 20 radio stations and 40 phone numbers. Verbal playback of nametag directories is provided by issuing the proper voice command (RADIO DIRECTORY or PHONE DIRECTORY).

Personal directories of nametags for phone dialing and radio station presets can be created and spoken command help is provided.

Language and Accent

Commands are given in English in a natural speaking voice, without having to pause between words. Most North American accents (for vehicles equipped with a US Voice Module) are understood without difficulty but the system also provides for voice training, if required.

Voice Commands

Voice commands are generally in the form of:

- System, e.g. RADIO
- Function, e.g. TUNE
- Action Required, e.g. 99.7 (to select the frequency)

NOTES: Voice commands cannot be given while a phone call is in progress.

While a voice command is being processed, the command can be canceled by pressing the Voice button again.

Audible feedback can be interrupted by pressing the Voice button during the verbal playback. In this case the command is not canceled.

Command Help

There are commands available which give spoken/visual help for the voice commands. This provides a useful reminder of the commands available while driving. The commands are: VOICE HELP; RADIO HELP; TAPE HELP; CD HELP; PHONE HELP; and CLIMATE CONTROL HELP.

System Operation

Initialization

When the ignition switch is turned to position II, the initialization of the system is carried out, which takes a few seconds. When complete, the system is ready to accept voice commands. If the voice button is pressed before initialization is complete, the message center display will show 'VOICE NOT READY'.

Audible Feedback, Confirmation & Prompts

For most voice commands, audible feedback of the command, as understood by the system, is available. Audible feedback may be turned on or off by giving the Voice Feedback command.

For the phone dial commands, confirmation of the number, before it is dialed, may be turned on or off by giving the phone feedback command. During some commands for voice training, the user is prompted by the system to give the next item of information.

For specific operation of all the controls, refer to the Owner's Voice Activation Handbook.

Voice Training

The Voice Activation System is able to interpret most English speakers without difficulty. If, however, it is found that commands are sometimes not being recognized, the voice training procedure can be carried out.

Voice Memories

The system has two memories (A and B) for storing the trained voices. The Voice Memory Directory command provides an indication of the availability of the two voice memories (Full or Available).

Giving Commands after Training

After Voice training the system will automatically recognize a speaker whose voice is held in voice memory. The system can still be used by other speakers with no loss of response.

Error Messages

In addition to the voice command prompts given by the system, the following error messages may be encountered. The messages are shown on the message center with voice confirmation (error tone or voice playback).

Message	Explanation
NO SPEECH DETECTED	The system did not detect any speech when the voice button was pressed
NAMETAG TOO LONG	A nametag must not take longer than three seconds to say
NAMETAG NOT UNIQUE	The nametag (or similar sounding name) has already been used
COMMAND NOT RECOGNIZED	The command was not recognized from the list of voice commands
HANDBRAKE MUST BE ENGAGED	The handbrake must be applied for voice training
RADIO MUST BE IN TUNER MODE	The sound system must be in radio mode before giving the Radio Store command
VOICE NOT READY	The voice button was pressed while the voice system was still initializing
TOO MANY DIGITS	The phone number is a Phone Enter command was too long

INTRODUCTION TO JAGUAR



1 INTRODUCTION TO XJ/XK

2 INTRODUCTION TO S-TYPE

- 2.1 Overview
- 2.2 Engine
- 2.3 PTEC Engine Management
- 2.4 Transmission
- 2.5 Suspension, Steering and Brakes
- 2.6 DATC Climate Control
- 2.7 Electrical Distribution System
- 2.8 Body Systems

2.9 Occupant Protection

- 2.10 Task Sheets



OCCUPANT PROTECTION

Supplementary Restraints System (SRS)

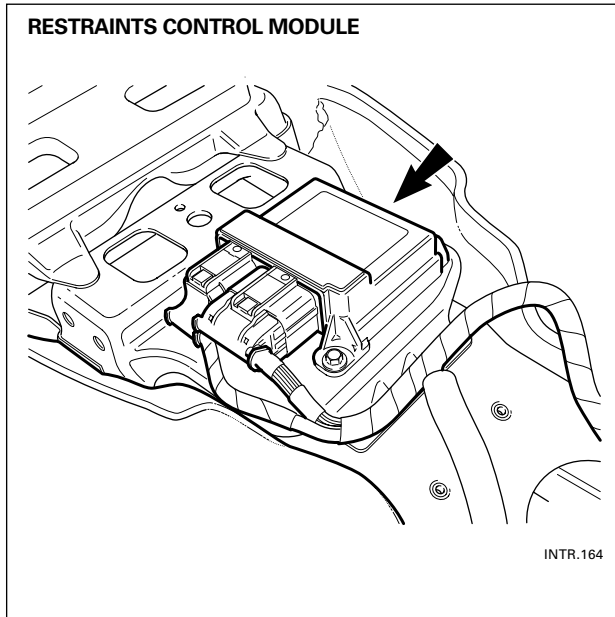

The Supplementary Restraints System (SRS) provides impact sensing, control of deployment and fault diagnosis of the control module, airbags, pre-tensioners and associated circuits. Most of these functions are carried out by the Restraints Control Module (RCM).

A front impact triggers the driver and passenger airbags and both pre-tensioners provided the impact is above the set threshold as detected by the two longitudinal sensors in the RCM.

When a side impact occurs, the lateral safing sensor in the RCM must also agree with an impact detection signal received from either the LH or RH Side Impact Sensor in order to deploy the corresponding airbag.

NOTE: An impact at an oblique angle may cause both frontal and side airbags to deploy, depending on how much lateral acceleration is sensed.

The RCM is bolted to the top of the driveshaft tunnel below the center stack. Due to the importance of the module being securely fixed to the vehicle body, the ground connection is made via a fixing bolt and is monitored by the diagnostic system. A bad connection causes a fault code to be generated.

NOTE: The torque settings are safety critical and the figures given in the JTIS Service instructions must be adhered to.

NOTES

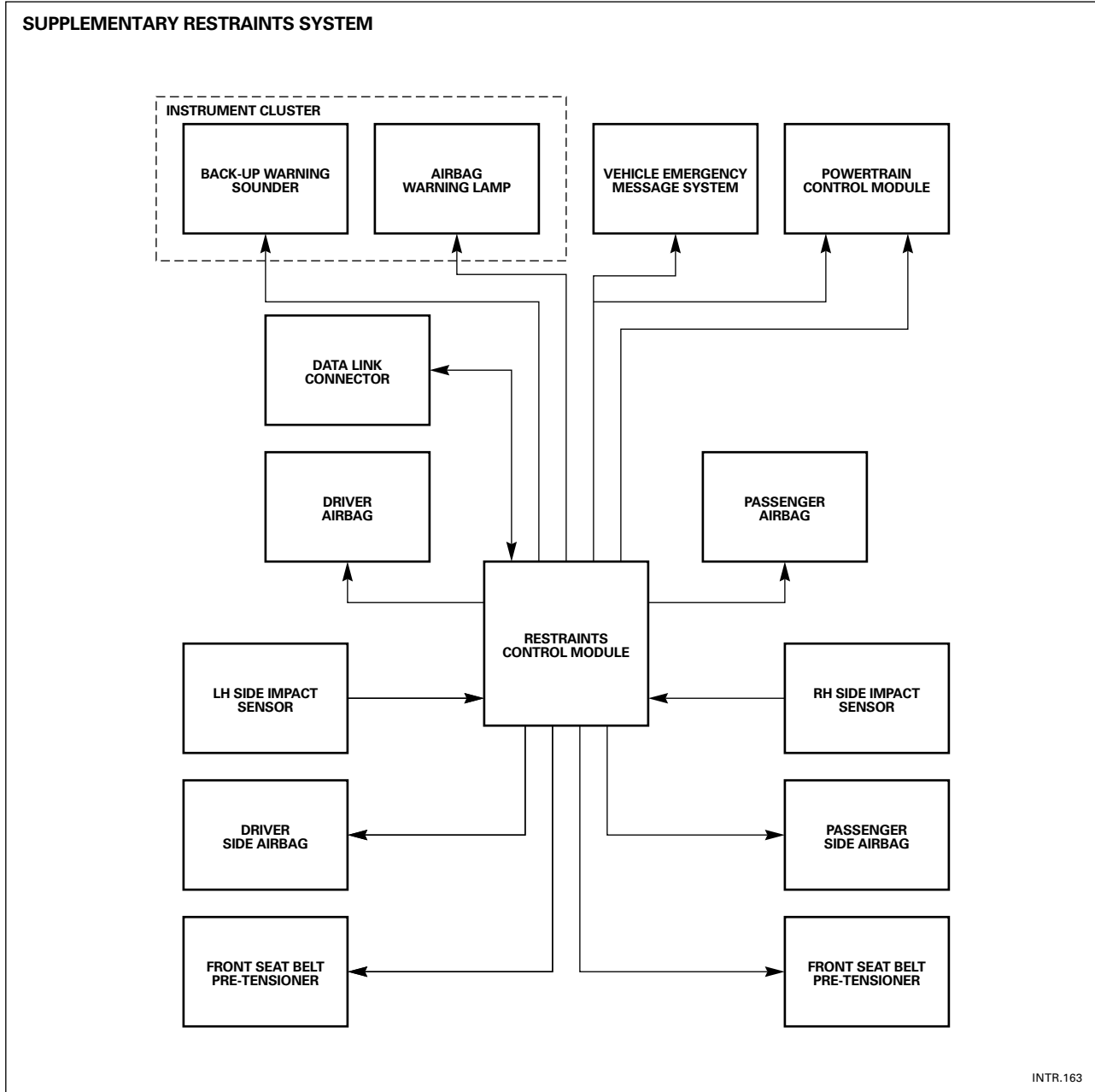

NOTES

OCCUPANT PROTECTION

Airbags

Driver Airbag

The driver airbag module is fitted in the center of the steering wheel and is of conventional design. A reduced charge propellant ('de-powered') is used to minimize impact effects where the driver is seated close to the wheel.

The module is secured by two side screws on the left and right underside of the steering wheel.

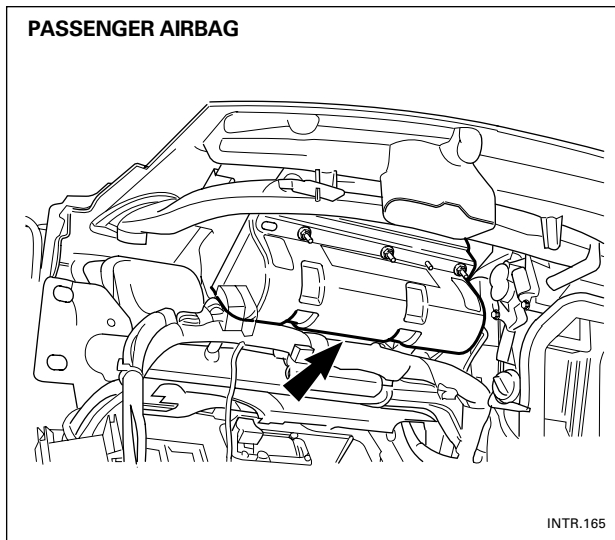

Passenger Airbag

WARNING: DO NOT PLACE OBJECTS ON THE PASSENGER AIRBAG DEPLOYMENT PANEL. INJURY COULD OCCUR IF THE AIRBAG CONTACTS AN OBJECT DURING INFLATION.

The passenger airbag uses a heated gas inflator (HGI) system instead of a solid propellant. This system is inherently 'clean' since the inflation gas is a lean hydrogen/air mixture and the by-products are water vapor and air. Although the gas is not classified as an explosive, the possible effects of accidental deployment when handling or working close to the unit are similar to those of other types of airbag. It is recommended that current safety procedures are also followed when handling the HGI modules.

The HGI airbag module has fewer components than previous types, consisting of:

- 140 liter bag
- Aluminum pressure vessel containing a mixture of 12% hydrogen/88% air at a pressure of 180 bar.
- Pressure vessel end plug with burst disc.
- Pyrotechnic igniter assembly fitted to pressure vessel end plug

The igniter is electrically triggered from the Restraints Control Module (RCM). When triggered, the igniter fires a high speed 'dart' along the length of the pressurized cylinder, producing a heated trail (due to friction) which causes rapid and even combustion of the gas throughout the cylinder. The igniter also ruptures the burst disc in the end plug, allowing the expanding gases from the pressure vessel to inflate the airbag. The airbag is a top mounted assembly and deploys in an upwards direction, climbing the windshield before folding downwards. After deployment, the bag deflates through two vents.

The airbag deployment door is an integral part of the top fascia molding. The airbag module is bolted to the underside of the fascia via a steel deployment chute and is also bolted to two brackets on the tubular cross car beam which supports the fascia assembly.

NOTE: The module is not handed. To access the airbag module, the complete fascia assembly must be removed.

Side Airbag

Side airbags are incorporated into the driver and front passenger seat squabs and are similar to those fitted to the XJ Series, using compressed argon to provide the inflation gas. The bag has a capacity of 19 liters and provides protection to both the head and chest regions.

The side airbag module is fixed to the outer seat frame and is located within a fabric deployment pocket. The pocket is stitched to the seat cover seam and when the module is triggered, this length of seam bursts to provide the deployment exit for the airbag.

If a damaged seat cover is to be replaced, the side airbag module must be removed and re-located in the deployment pocket of the new seat cover.

The complete seat must be replaced if the airbag has been deployed.

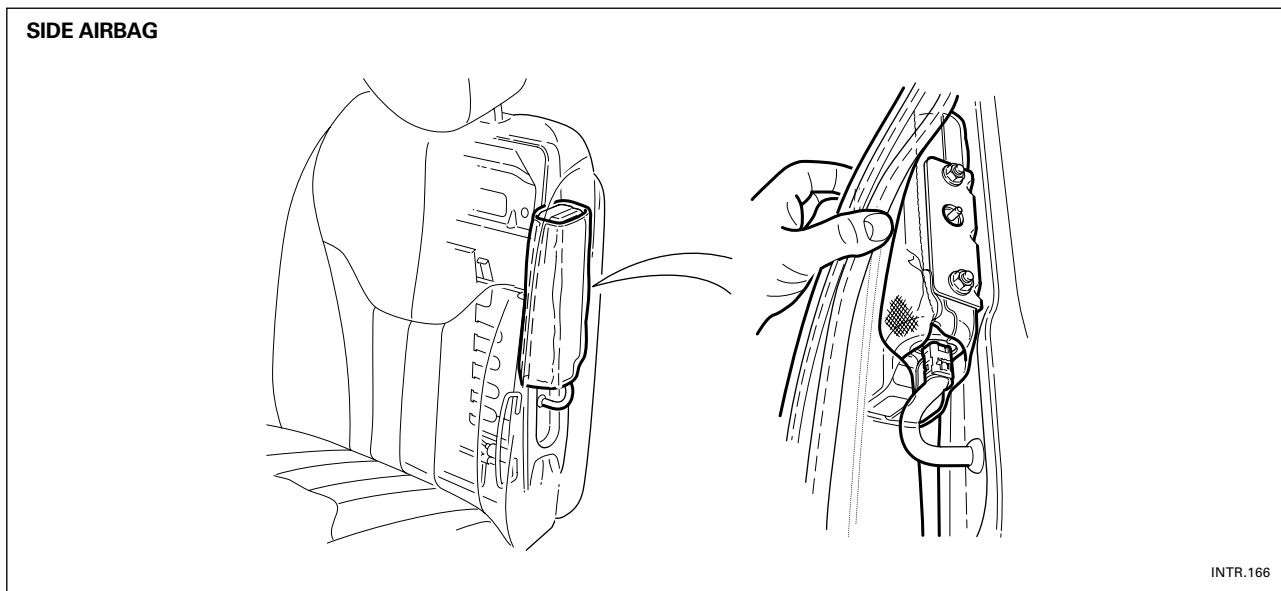

NOTES

OCCUPANT PROTECTION

Seatbelts

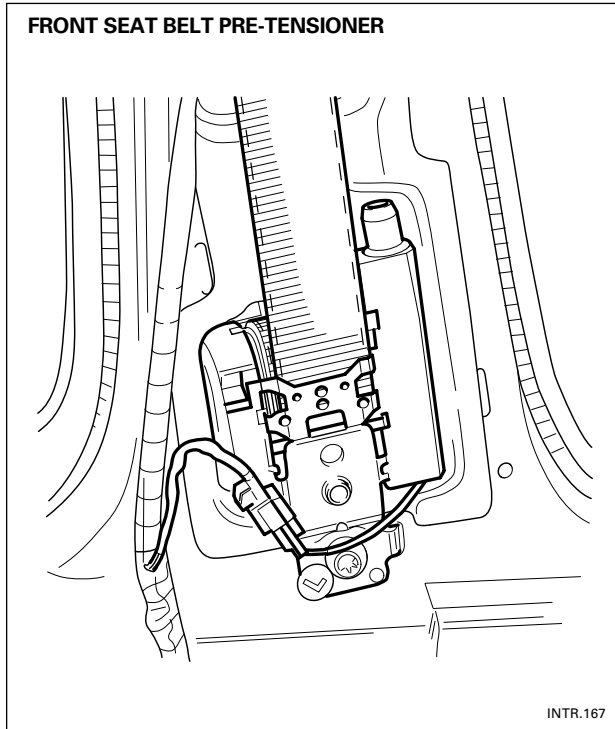

Front Seatbelts and Pre-tensioners

The front seatbelts are of the inertia reel type with integral pre-tensioners and torsion bar load limiters fitted to the reel assemblies. The lower anchorage and buckle strap are mounted on the moving seat slides to maintain optimum belt geometry. The shoulder anchorage is fixed to the 'B' post via a four position height adjuster. An automatic locking retractor (ALR) is incorporated in the passenger belt reel assembly to provide child seat security.

A compact type of pre-tensioner is fitted to the front seatbelt reel assemblies. The reduced size is achieved by the use of rack and pinion gearing to retract the seatbelt reel when the unit is fired. The initiator is a conventional pyrotechnic device which is electrically triggered from the Restraints Control Module (RCM).

Fault diagnosis of the pre-tensioner firing circuits is carried out by the RCM and the presence of a fault is indicated by the airbag warning lamp (see Diagnostics).

Note that plastic belt guides are fitted to the 'B' post; if the pre-tensioners are fired, these guides will fracture.

NOTES

INTRODUCTION TO JAGUAR



GENERAL INFORMATION

1 INTRODUCTION TO XJ/XK

2 INTRODUCTION TO S-TYPE

3 INTRODUCTION TO X-TYPE

3.1 Overview

3.2 Engine

3.3 Engine Management

3.4 Transmissions and Driveline

3.5 Suspension, Steering and Brakes

3.6 Climate Control

3.7 Electrical Distribution System

3.8 Body Systems

3.9 Occupant Protection

3.10 Task Sheets



OVERVIEW

General Information

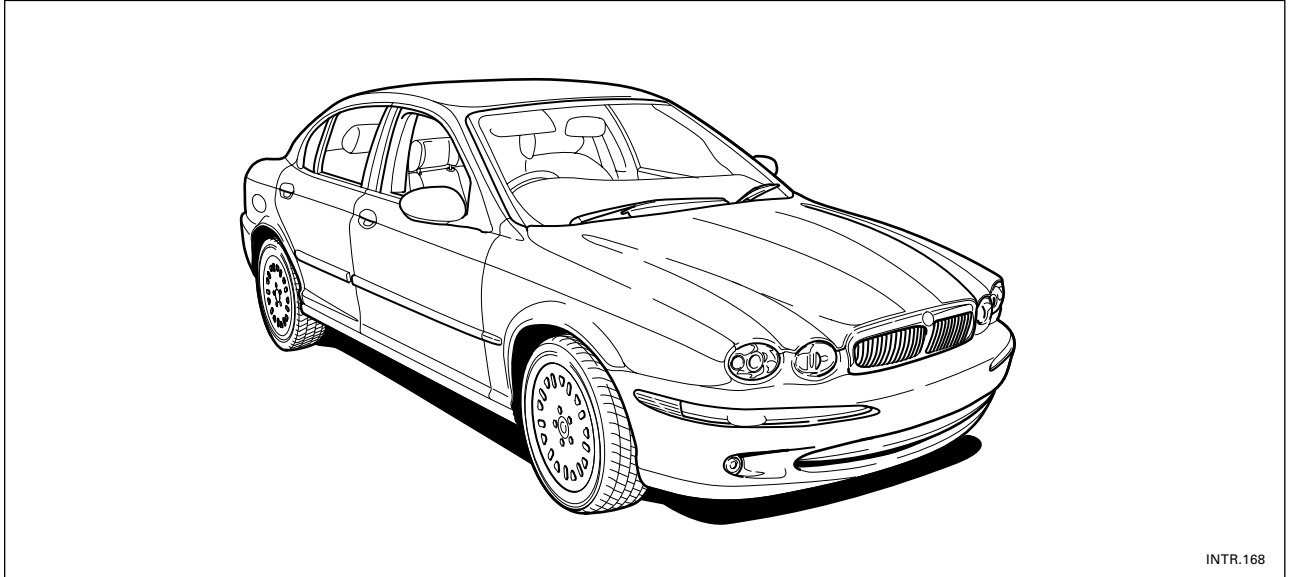

The Jaguar X-TYPE is an all-wheel drive (AWD), elegant small luxury sedan, which combines the contemporary expression of traditional Jaguar product attributes with excellent driving dynamics, package and functionality.

The powertrain comprises a 2.5 liter or 3.0 liter transversely mounted V6 engine, derived from the engine currently used in S-TYPE, coupled with a five-speed automatic transmission or a five-speed manual transmission.

Like previous Jaguar models, X-TYPE utilizes CAN, SCP and ISO9141 communication networks. In addition, it uses an optical network (D2B) for very high speed transfer of audio data to support features such as navigation, voice activation and television.

NOTES

Standard features for the 2.5 liter V6 model include:

- Front seat-mounted side airbags
- Side curtain airbags
- Driver seat-track position sensing
- Passenger seat weight sensing
- All-wheel drive
- Leather seats
- Leather gear shift knob (manual)
- Wood gear shift knob (automatic)
- Rear electric windows
- Power driver/passenger seats
- Steering wheel controls
- Wood door trim (front/rear)
- Automatic air conditioning with pollution filter
- Front center sliding armrest
- Chrome exterior trim

The Sports model comprises a similar range of features, however, 17" sports wheels and a sports suspension are fitted as standard.

Optional features, which vary depending on market and vehicle specification, include:

- Dynamic stability control, which assists the driver in maintaining directional control of the vehicle
- Xenon, high-intensity discharge lamps (for improved driver visibility) supplied complete with automatic headlamp leveling and headlamp power wash
- Autolamp which, when selected, automatically activates the headlamps should the ambient light fall below a predetermined level
- A message center (integral to the instrument cluster) that displays warnings and information for use by both the driver and the technician
- Telematics display which provides a user interface to support navigation, television, climate control, cellular phone and entertainment systems
- Parking aid, a system which gives the driver audible warning of obstructions that could damage the vehicle during reversing
- Manual or automatic climate control
- Single CD player or CD changer
- Mini-disc player
- Power lumbar support
- Voice activation system
- Vehicle emergency monitoring system
- Power foldback mirrors
- Sliding roof
- Premium entertainment system

As with current vehicles, the X-TYPE is fitted with variable ratio power steering and ABS brakes as standard.

Security features include immobilizer and alarm; intrusion sensors and the inclination sensor are available as options. The key fob transmitter has radio frequency operation with an encrypted rolling code to help prevent theft of the vehicle.

NOTES

OVERVIEW

Dimensions

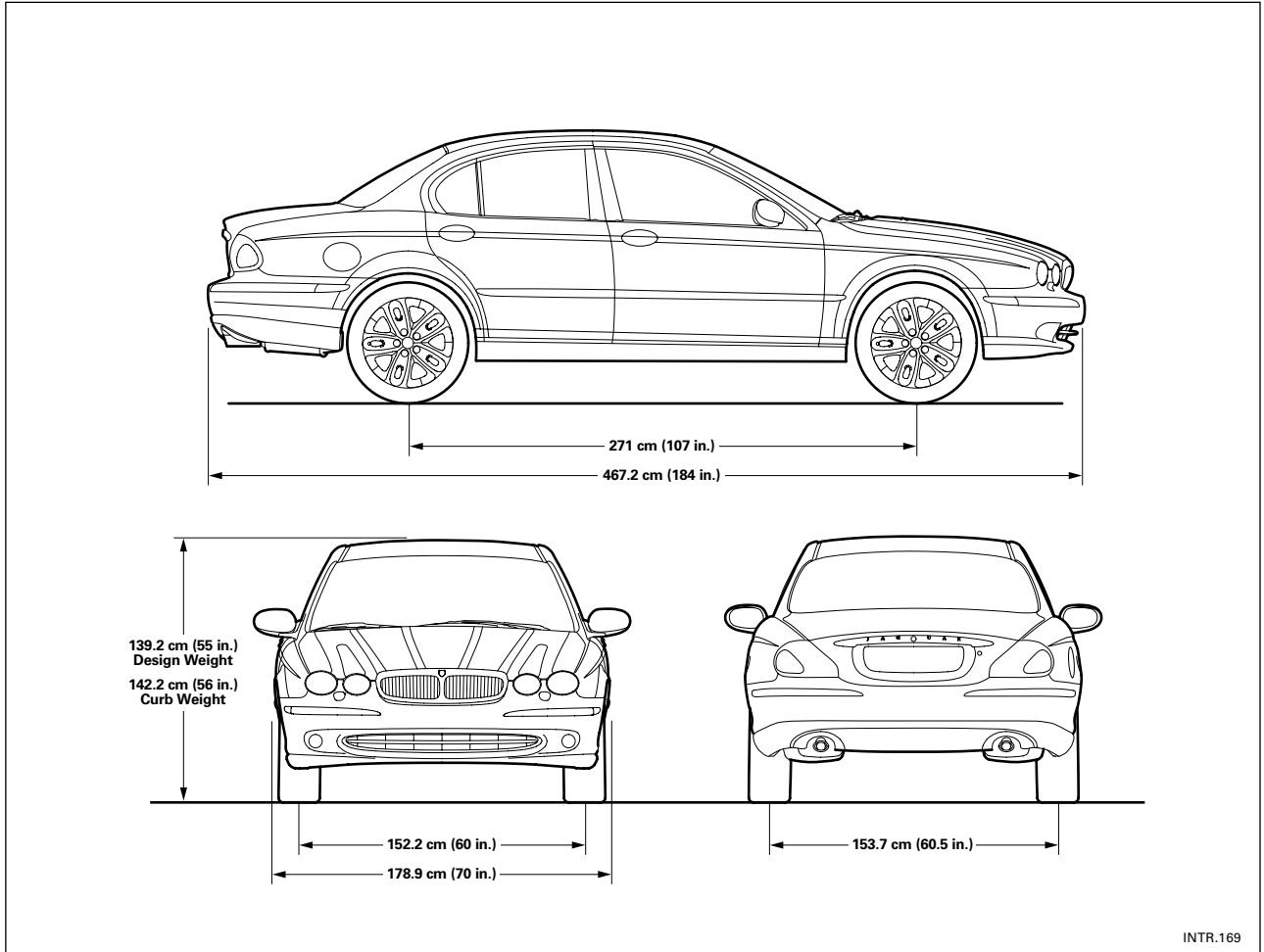

Design weight condition refers to a vehicle at curb weight including 33% optional equipment, plus occupant load dependent upon the number of seats in vehicle. Curb weight condition refers to the complete vehicle with all fluids filled to capacity and without occupants, optional equipment or luggage. Minimum ground clearance (fuel tank undertray to ground) when measured at gross vehicle weight (GVW) is 112.90 mm (4.4 in).

NOTES

Identification Plates and Labels

IDENTIFICATION PLATE AND LABEL LOCATION

QUICK REFERENCE VIN PLATE

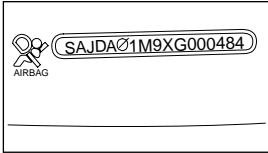

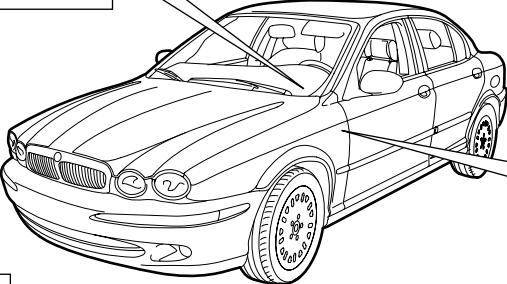

CERTIFICATION LABEL

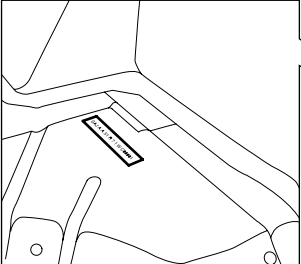

OFFICIAL VIN PLATE

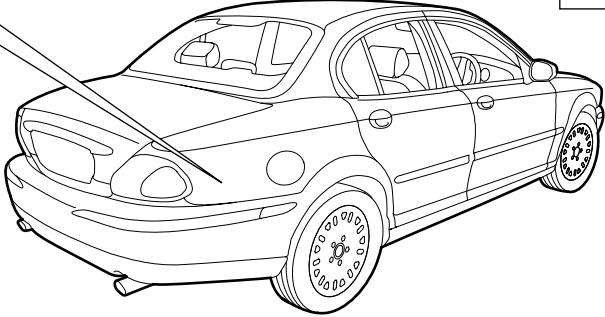

CERTIFICATION LABEL

MFD BY JAGUAR CARS LTD
COVENTRY ENGLAND

MFD DATE GWWR

GAWR F R

THIS VEHICLE CONFORMS TO ALL APPLICABLE FEDERAL MOTOR
VEHICLE SAFETY BUMPER AND THEFT PREVENTION STANDARDS
IN EFFECT ON THE DATE OF MANUFACTURE SHOWN BELOW

VEH IDENT NO.

TYPE PASSENGER CAR

PAINT TRIM

INTR.170

Production Sequence Numbers

X-TYPE Models 2.5-liter V6, 3.0-liter V6

Model Year	Production Sequence Numbers
2002 (Model year I.D. "2")	C00001 –

NOTES

OVERVIEW

Vehicle Jacking and Lifting

There are four jacking points, two on each side of the vehicle on the underside of the floor. Two indented triangular jack location points are provided on each sill cover.

CAUTION:

- Jacking and lifting points are critical.
- Vehicle support stands should only be used in conjunction with cushioned pads.

Refer to JTIS for detailed information.

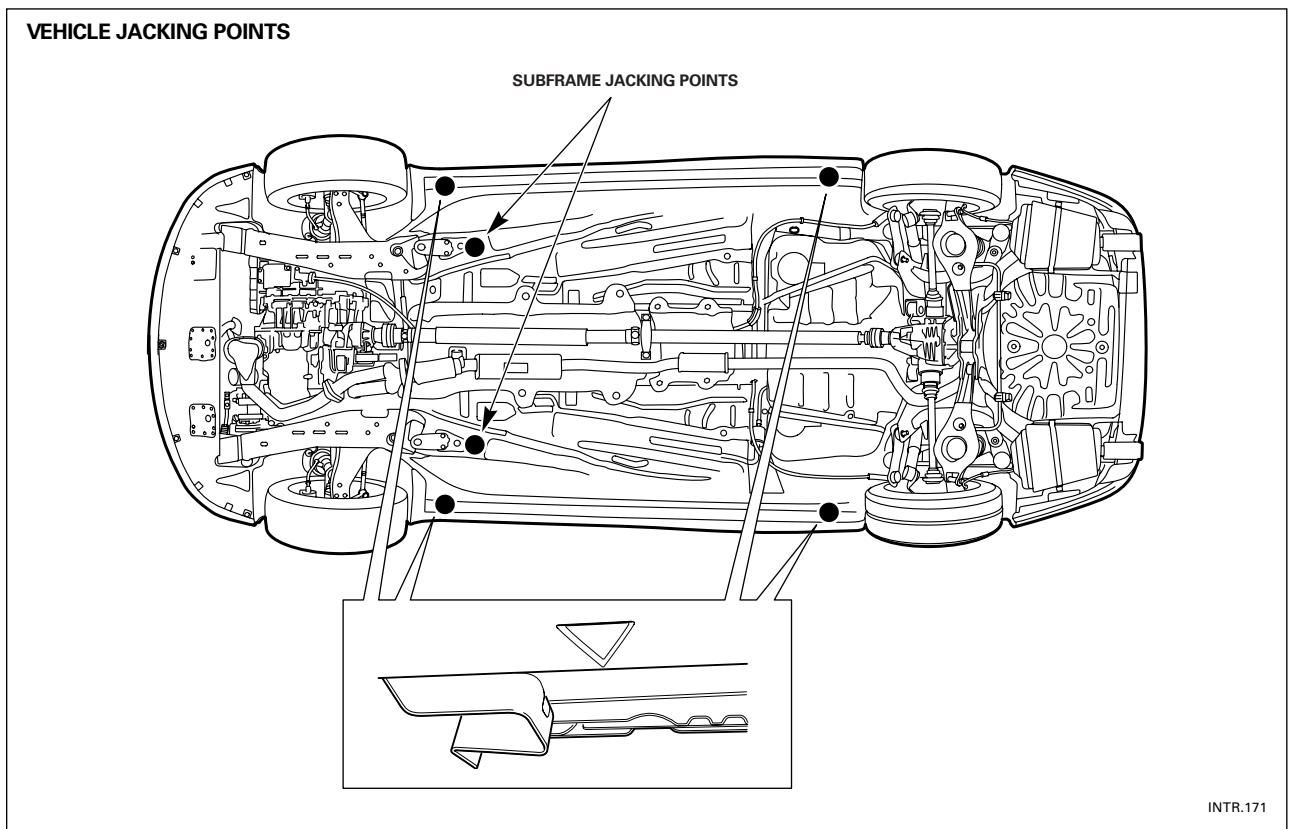

Vehicle Recovery and Towing

It is preferred and recommended that vehicle recovery is performed using a flatbed transporter. Otherwise, the following guidelines should be observed.

Vehicles with all four wheels on the ground

Provided there is no damage to the transmission, the vehicle can be towed with all four wheels on the ground for a maximum distance of 50 km (30 miles) at a speed not exceeding 50 km/h (30 mph).

Vehicles with only the rear wheels on the ground

To prevent damage to the automatic transmission while towing the vehicle with only the rear wheels on the ground, the towing distance must be restricted to 0.8 km (0.5 miles). The towing speed must not exceed 50 km/h (30 mph).

INTRODUCTION TO JAGUAR



GENERAL INFORMATION

1 INTRODUCTION TO XJ/XK

2 INTRODUCTION TO S-TYPE

3 INTRODUCTION TO X-TYPE

3.1 Overview

3.2 Engine

3.3 Engine Management

3.4 Transmissions and Driveline

3.5 Suspension, Steering and Brakes

3.6 Climate Control

3.7 Electrical Distribution System

3.8 Body Systems

3.9 Occupant Protection

3.10 Task Sheets



ENGINE

Introduction

The X-TYPE is the first Jaguar vehicle range to be fitted with a transverse engine. This modification has resulted in the 2.5 liter and 3.0 liter AJ V6 engines, which are both variants of the 3.0 liter S-TYPE engine redesigned to accommodate the new powertrain configurations.

The base engine is manufactured and assembled at the same engine plant in Cleveland, Ohio, using the same facilities as the current S-TYPE engine.

Base engine features – variation from 3.0 liter S-TYPE:

- Continually variable valve timing.
- New cylinder heads and gaskets.
- Cast iron camshafts with steel tappets.
- Redesigned three-stage variable geometry intake system (identical concept and operating parameters to the 3.0L S-TYPE).
- Redesigned exhaust manifolds – fabricated on the front bank and cast on the rear.
- Rear end auxiliary driven water pump on the front (left) bank – exhaust camshaft.
- Redesigned front end auxiliary drive layout.
- Redesigned front cover including engine mounting location.
- Redesigned engine mounts to suit transverse installation.
- Redesigned oil pan to suit engine installation.
- Denso engine management.
- 5w/30 GF3 engine lubricant.
- Redesigned breather system due to water flow pipe to rear, oil separator in cam cover instead of Vee.
- Full coolant flow oil cooler.

NOTES

JAGUAR X-TYPE AJ V6 ENGINE

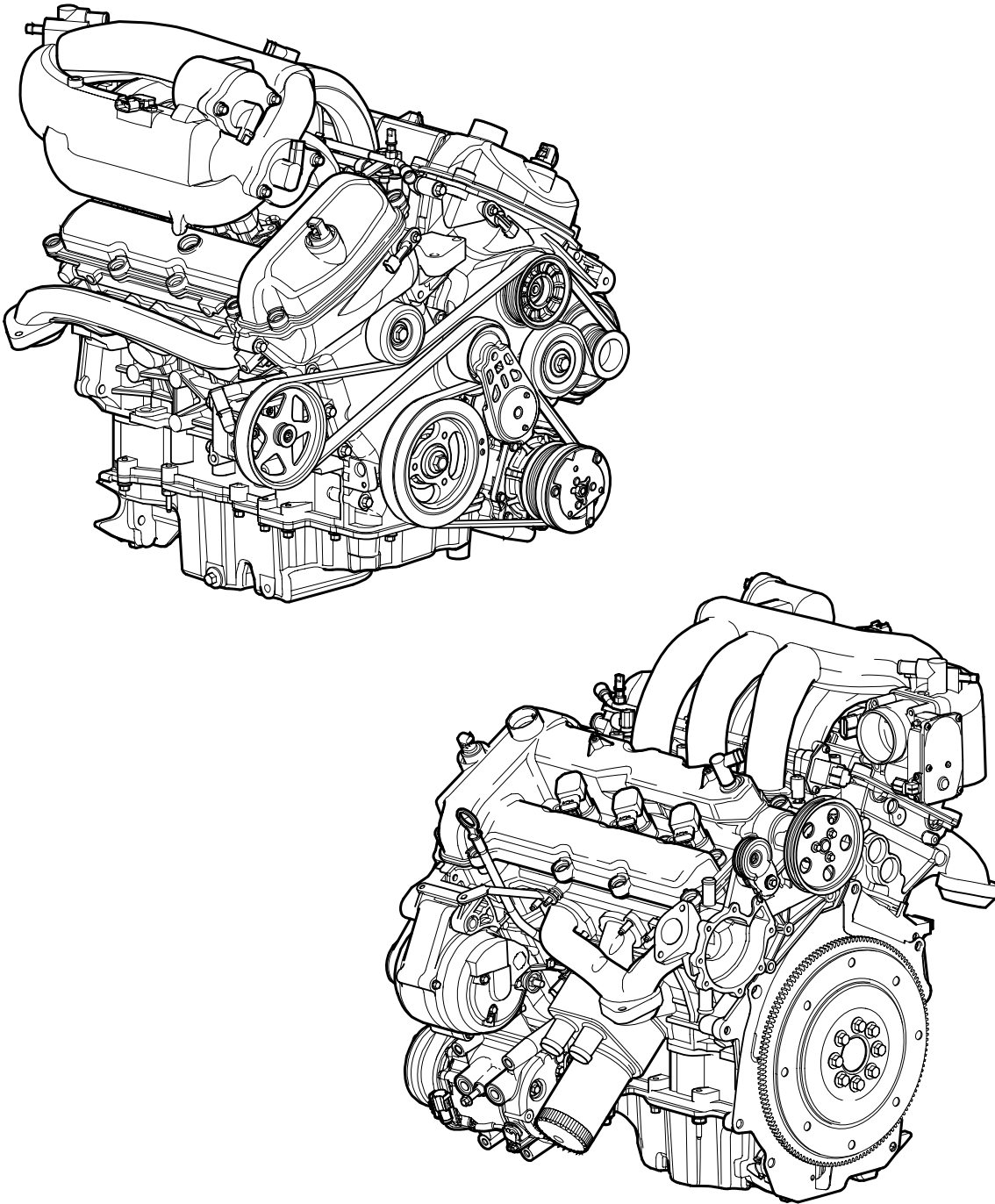

INTR.172

V6 ENGINES

Location of Identification Codes

The engine identification code is on a label behind the drive belt, stuck to the front cover. The serial number and emission code are stamped on the left-hand side of the engine at the assembly plant. Main bearing selection codes are inked on the crankshaft and stamped on the back of the engine block.

3.0 Liter Engine

Engine code	Emissions	Market	Transmission
1G-730-AA	LEV	All	Auto
1G-731-AA	LEV	All	Manual

2.5 Liter Engine

Engine code	Emissions	Market	Transmission
1G-430-AA	LEV	All	Auto
1G-431-AA	LEV	All	Manual

Engine Identification using the VIN

The eleventh digit of the VIN indicates which engine is fitted on the vehicle. An “X” indicates that the vehicle is fitted with a 2.5-liter engine; a “W” indicates that the vehicle is fitted with a 3.0-liter engine. For example:

SAJEB53D52XC000236 = 2.5 liter engine; SAJEA51CX2WC000235 = 3.0 liter engine.

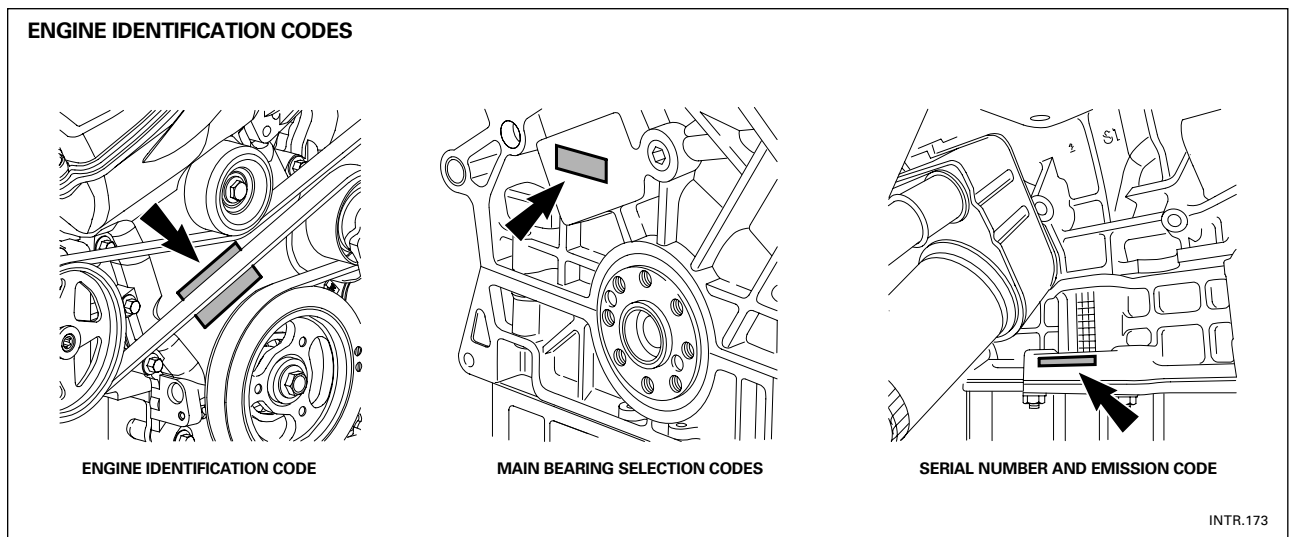

NOTES

Engine Specifications

	X-TYPE 3.0L	X-TYPE 2.5L
Cylinder configuration	60° V6	60° V6
Bore	89.0 mm	81.6 mm
Stroke	79.5 mm	79.5 mm
Swept volume	2967 cc	2495 cc
BHP	231 @ 6800 rpm (172 kw)	194 @ 6800 rpm (145 kw)
Torque (Nm)	284 @ 3000 rpm	244 @ 3000 rpm
Firing order	1 - 2 - 3 - 4 - 5 - 6	1 - 2 - 3 - 4 - 5 - 6
Engine oil	5w-30GF3	5w-30 GF3
Oil capacity (w/filter)	6.4 liters	6.4 liters
Coolant capacity	8.25 liters	8.25 liters
Spark plugs	AWSF22F	AWSF22F
Plug gap	1.3 – 1.45 mm	1.3 – 1.45 mm
Valve clearance (cold)	Inlet 0.175 – 0.225 mm Exhaust 0.325 – 0.375 mm	Inlet 0.175 – 0.225 mm Exhaust 0.325 – 0.375 mm

Engine Cylinder Numbering

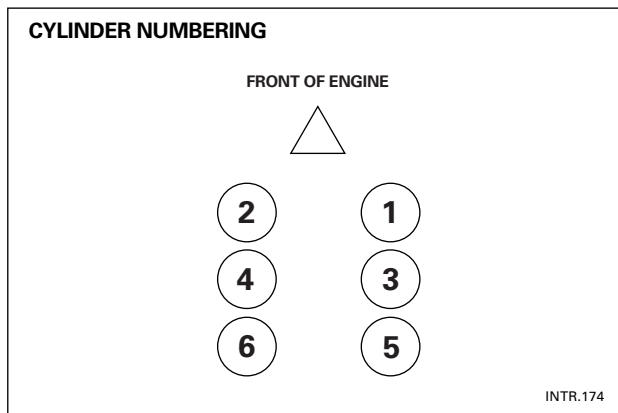

NOTES

INTRODUCTION TO JAGUAR



GENERAL INFORMATION

1 INTRODUCTION TO XJ/XK

2 INTRODUCTION TO S-TYPE

3 INTRODUCTION TO X-TYPE

3.1 Overview

3.2 Engine

3.3 Engine Management

3.4 Transmissions and Driveline

3.5 Suspension, Steering and Brakes

3.6 Climate Control

3.7 Electrical Distribution System

3.8 Body Systems

3.9 Occupant Protection

3.10 Task Sheets



ENGINE MANAGEMENT

Overview

The engine control system consists of sensing devices, an engine control module (ECM) and actuating devices. The sensors continuously measure the requirements of the driver and operating conditions of the engine. The ECM evaluates this information using data tables (maps) and calculations, and uses the results to command an appropriate response from the actuating devices. The total system provides the necessary accuracy and adaptability to minimize exhaust emissions and fuel consumption, provide optimum driveability under all conditions, minimize evaporative fuel emissions, and provide system diagnostics if malfunctions occur.

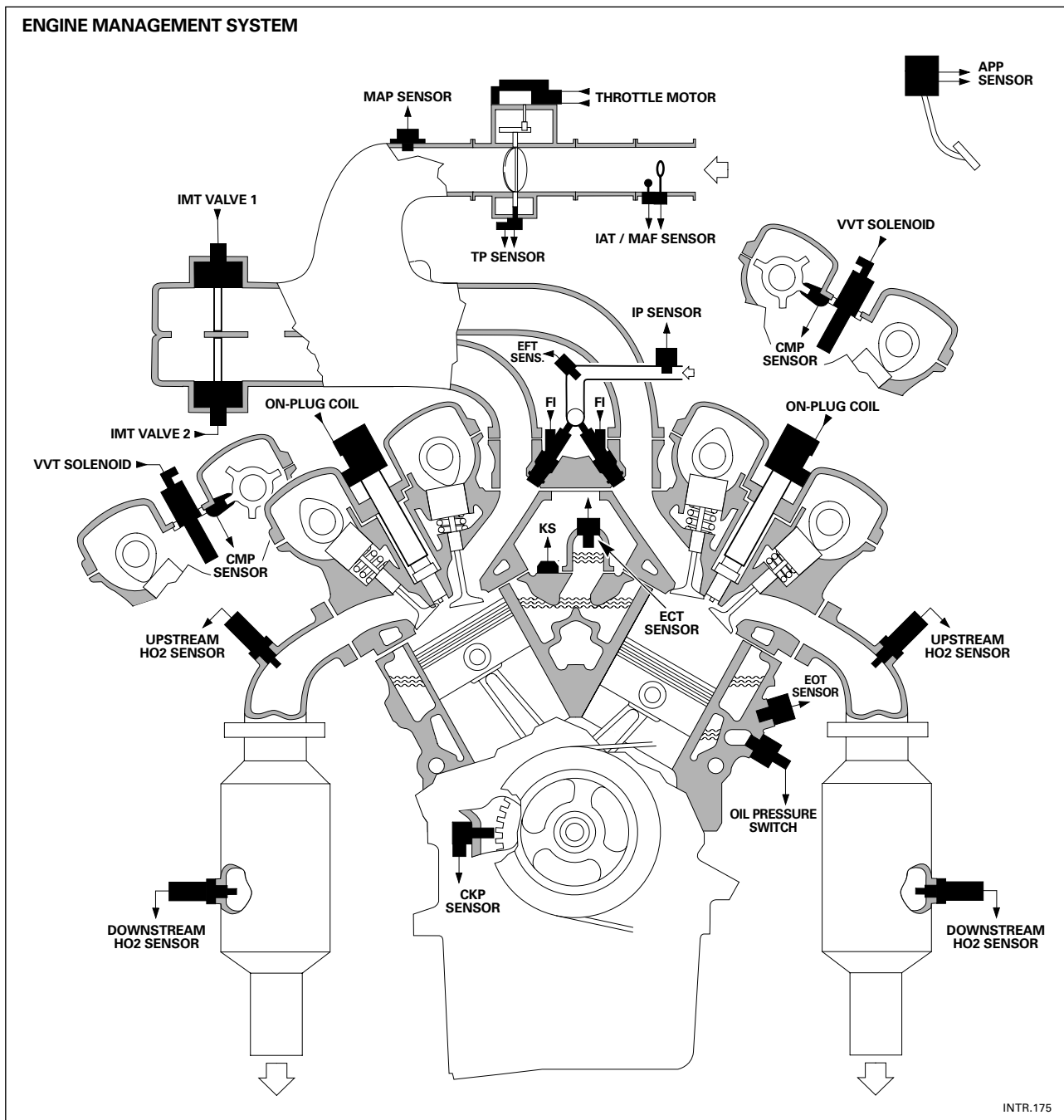

ENGINE MANAGEMENT

Engine Control Module

ECM Data Recorder

The flight data recorder captures vehicle data in the event of an incident in the field. This data may be used for problem diagnosis and displayed using WDS.

The ECM will utilize an area of its RAM to provide a 10 second rolling buffer for a number of parameters defined by Jaguar. The data in the rolling RAM buffer will be refreshed every 256 milliseconds by the ECM and will be transferred to an area of EEPROM once a trigger condition has been met.

The data storage area in EEPROM is divided into two areas (Area A and Area B) and the data transferred into these areas from RAM will depend on the trigger condition that has been detected. The data in these areas will represent events over a calibrated time prior to the trigger event followed by the remaining portion of the 10-second buffer after the trigger event.

Area A will only store data associated with the Area A trigger condition and likewise Area B will only store data associated with the Area B trigger conditions. The Data stored in area A will be overwritten with new data every time a trigger condition occurs.

The data stored in area B will be overwritten depending on the priority of the triggered data. The trigger priorities are as follows:

Highest priority

A fuel pump cut off by the inertia switch being tripped will trigger data rated as the highest priority. This data will overwrite all other data and can only be cleared using WDS.

Medium priority

A throttle default will trigger data rated at a medium priority. This data will overwrite any lower priority data. It will not overwrite medium or highest priority data.

Lowest priority

An engine that fails to start or an engine that starts and stumbles will trigger data rated as the lowest priority. It will not overwrite high or medium priority data.

Whenever data is captured in EEPROM memory, the odometer reading and stored DTCs are also written to the EEPROM. DTC P1582 (Flight Recorder Information Available) will be logged whenever data is stored in either Area A or Area B.

To access the recorded information you can choose to read DTCs from the vehicle, and select the DTC (P1582) that indicates that ECM recorded data is available. The user may choose to investigate the DTC by pressing the DTC pin-point button. This causes the application sub-tab to appear within DTC Monitor. This is consistent with existing methods of DTC investigation. The existing functionality of DTC Monitor will allow user help and the required DTC clearing operations to be performed as with any other DTC.

Or, the user can select Vehicle Configuration, then Special Applications, then select the ECM Data Recorder application from the Special Applications menu.

NOTES

Trigger Conditions for Data Storage

Condition	Trigger	Storage Area	Trigger Mode
Engine Stalls	Engine speed held above a calibrated threshold for more than a calibrated period of time, and then dropping below a calibrated threshold.	A	1
Engine fails to start	Engine speed remaining below a calibrated threshold for longer than a calibrated period of time while the engine is being cranked.	B	2
Engine starts and stumbles	Engine speed exceeding a calibrated threshold and then dropping below a calibrated threshold without meeting the conditions for “engine stall”.	B	2
Throttle default	Entry into throttle default mode	B	4
Fuel pump cut off by inertia switch	Inertia switch going open circuit	B	5

ECM Data Recorder Parameters

- Throttle position
- Driver demand
- Engine speed
- Vehicle speed
- Fuel pulse width
- Ignition
- MAF volts
- Coolant temperature
- Air temperature
- PATS status
- CAN traction status
- Gear position selected
- Gear position actual
- Brake switch status
- Cruise control mode
- Fuel intervention
- Throttle failure flag
- Ignition angle
- Fuel pressure
- Battery voltage

Start Time Monitor

The start time monitor is another feature within the data recorder function. This will display the length of time taken to start the vehicle in milliseconds for each of the last 50 engine starts. The ECM considers the engine to have started when the engine speed exceeds 700 rpm.

The display will also indicate the engine temperature for each of the 50 starts as either low, medium or high. The following parameters are used:

- Low: < 15 degrees centigrade (25 starts)
- Medium: 15 – 70 degrees centigrade (10 starts)
- High: > 70 degrees centigrade (15 starts)

WDS will also display the total number of times the engine has been started and the average length of time taken. This data will be reset if the vehicle battery is disconnected.

INTRODUCTION TO JAGUAR



GENERAL INFORMATION

1 INTRODUCTION TO XJ/XK

2 INTRODUCTION TO S-TYPE

3 INTRODUCTION TO X-TYPE

3.1 Overview

3.2 Engine

3.3 Engine Management

3.4 Transmissions and Driveline

3.5 Suspension, Steering and Brakes

3.6 Climate Control

3.7 Electrical Distribution System

3.8 Body Systems

3.9 Occupant Protection

3.10 Task Sheets



TRANSMISSIONS AND DRIVELINE

Automatic Transmission

The JF506E automatic transmission has been developed for use by Jaguar. Made in Japan by JATCO, the transmission employs a transmission control module (TCM), three rotational speed sensors, and nine gear change / pressure solenoids to achieve refined gear change control with excellent response to changing driving conditions.

JF506E can be interpreted as follows:

- J Japan Automatic Transmission Company
- F Front wheel drive
- 5 5 forward gears
- 06 Version number
- E Electronic control

The transmission ID is stamped on the transmission; for example:

PL 000 = 3.0 liter or PL 001 = 2.5 liter.

This description is followed by the production year and month and a 5 digit serial number; for example:
08 XXXXX.

Specifications

Transmission fluid	Fill for life with Idemitsu. Not compatible with other transmission oils.
Transmission capacity	8.8 liters
Fluid cooler	Air cooler with thermostat
Torque capacity	295 Nm
Torque converter	With single plate lock-up clutch and torsional damper
Stall speeds	2.5 liter – 2610 rpm; 3.0 liter – 2610 rpm
Weight	101 kg
Ratios:	
First	3.80:1
Second	2.13:1
Third	1.36:1
Fourth	0.93:1
Fifth	0.68:1
Reverse	2.97:1
Final drive	3.8:1
Recovery	0.5 miles @ 30 mph

NOTES

JF506E AUTOMATIC TRANSMISSION

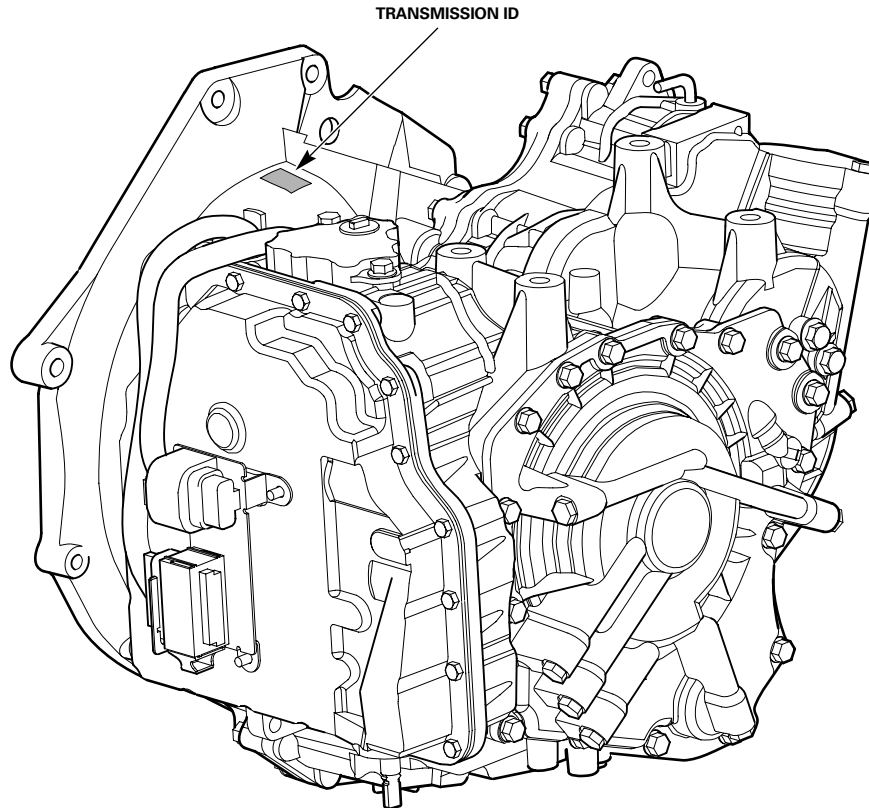

INTR.176

NOTES

TRANSMISSIONS AND DRIVELINE

Manual Transmission

The MTX 75 manual transmission is a “two-shaft transmission”. MTX 75 can be interpreted as follows:

- M Manual
- T Transmission
- X Transaxle (front wheel drive)
- 75 The distance between input and output shafts in millimeters

The aluminum housing of the manual transmission consists of two closed sections. The purpose of the reinforcing ribs on the transmission housing is to reduce noise and vibration and to contribute to powertrain bending stiffness.

With the “two-shaft transmission,” all the gear wheels are in permanent mesh. In each gear, the required ratio is achieved by means of a pair of gear wheels.

When Reverse is selected, an idler gear changes the direction of rotation of the output.

The input and output shafts run in taper roller bearings.

To further improve stability and gear shifting, a maintenance-free cable operating mechanism is used.

All the gear wheels, including reverse gear, are helical cut, synchronized, and run on needle roller bearings.

First, second, and third gear have double synchronization. The advantages of double synchronization are that the transmission runs quietly, gearshifts are smooth, and the assembly is compact and light in weight.

Differential (Front)

The main components of the differential are:

- Final drive wheel
- Drive sleeve
- Differential housing with two taper roller bearings
- Two differential side gears
- Two differential pinions and cross shaft

The transmission and differential are installed in a two-part aluminum housing that is flange-mounted to the engine.

The driveshafts have serrated teeth and are secured with a snap ring.

The torque is transmitted from the final drive gear via the cone shaped drive sleeve into the transfer box. The transfer box then splits the torque between the front and rear wheels. An intermediate driveshaft couples the transfer case to the differential housing (via planetary set sun gear), transmitting the front wheel drive torque. Torque is then transmitted from the differential housing via the crosspin to the differential pinions, which in turn drive the differential side gears; these in turn drive the driveshafts.

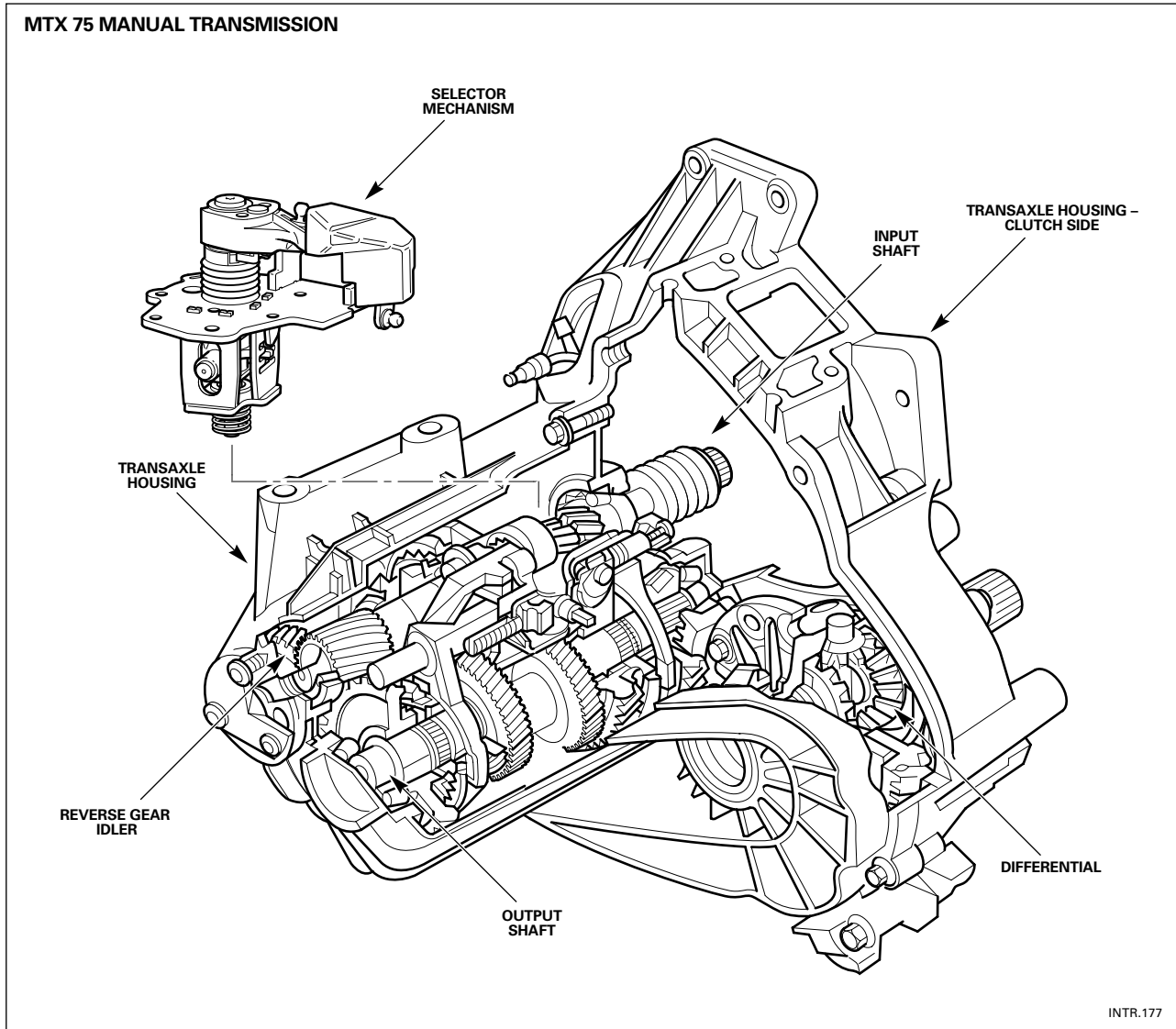

NOTES

TRANSMISSIONS AND DRIVELINE

Manual Transmission (continued)

Transmission ID

The transmission can be identified from the information on the type data sticker. This label is located on the transmission housing. For example, a label that has the information 1G A 1 9M02 000436 can be interpreted as follows:

- 1G Plant
- A Shift
- 1 Line
- 9M02 Build date: 02.12.99
- 000436 Serial number

Specifications

Torque capacity	300 Nm
Weight	48.6 kg
Transmission fluid	ESD-M2C186-A
Transmission capacity	1.75 liters
Brake fluid	DOT 4 ESD-M6C57-7
Ratio:	
First	3.42
Second	2.14
Third	1.45
Fourth	1.03
Fifth	0.77
Rev.	3.47
Final drive	3.8
Recovery	30 miles @ 30 mph (flat bed)

NOTES

Shift Mechanism

The external shift mechanism consists of the gear lever housing with the gear lever; the internal shaft mechanism housing, which accommodates the shift shaft with the internal shift mechanism; and two cables.

At the transmission end, the cables are secured to a bracket on the transmission housing by means of abutment sleeves; they are attached to the shift shaft by means of an end fitting with a ball socket. The internal shaft mechanism is operated through the shift shaft.

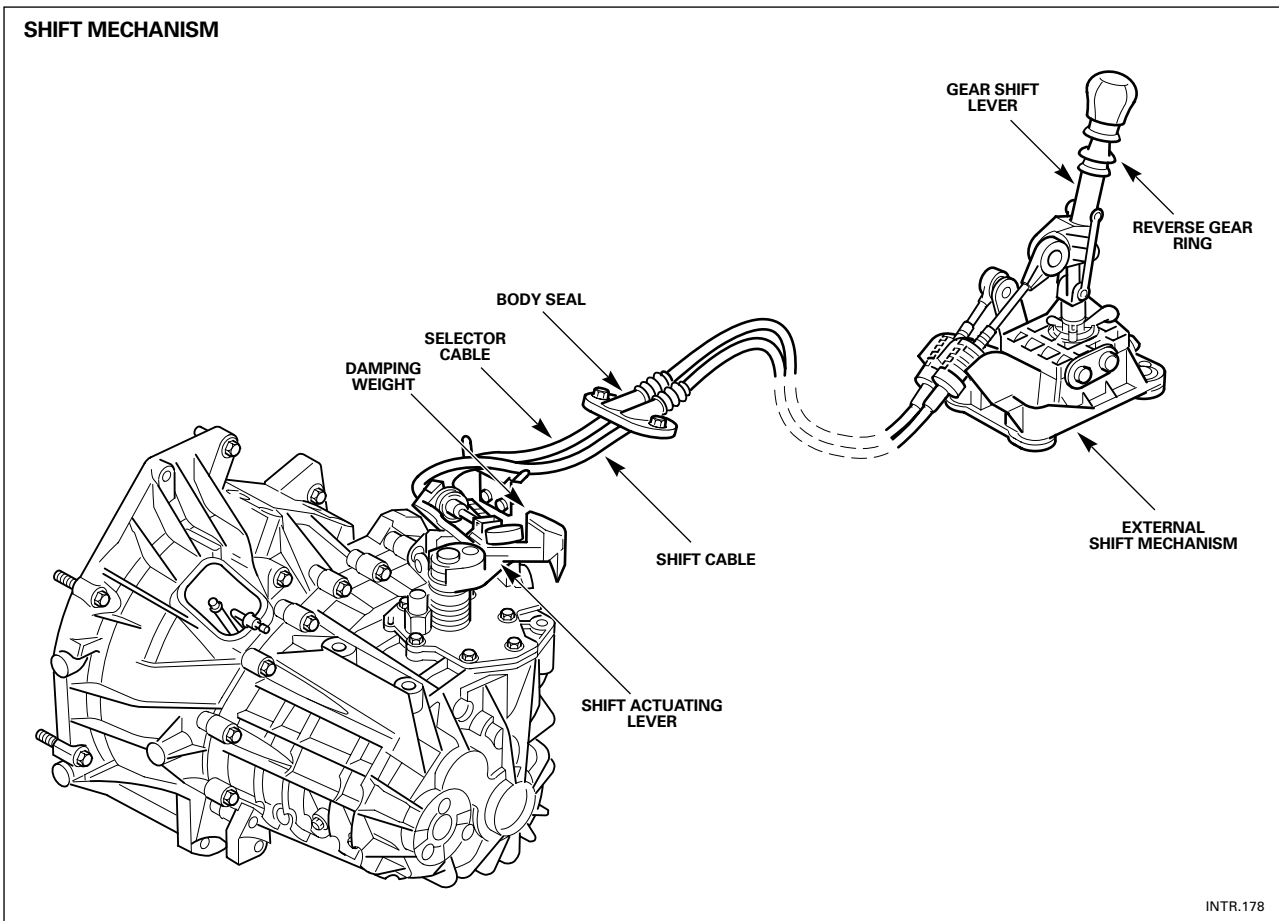

NOTES

TRANSMISSIONS AND DRIVELINE

Manual Transmission (continued)

Clutch

- The clutch is a hydraulically-operated, self-adjusting system which improves operation and driver comfort by enabling a constant pedal pressure to be applied as the friction faces of the clutch plate wear.
- The system employs a concentric slave cylinder, located on the transaxle's input shaft behind the pressure plate. The concentric slave cylinder eliminates the need for a release lever mechanism and improves operating efficiency.
- The clutch pedal, which is mounted on a combined assembly with the brake pedal, employs an assister spring to reduce pedal load.
- The clutch master cylinder is directly actuated by the clutch pedal, and shares a common fluid reservoir with the brake system.
- Operation of the clutch pedal when the vehicle is in speed (cruise) control mode activates a switch which supplies a signal to the ECM to deactivate speed control.
- To enable engine starting the clutch pedal must be fully depressed. This activates a switch which sends a signal to the ECM to provide one of the requirements for activating the starter relay.

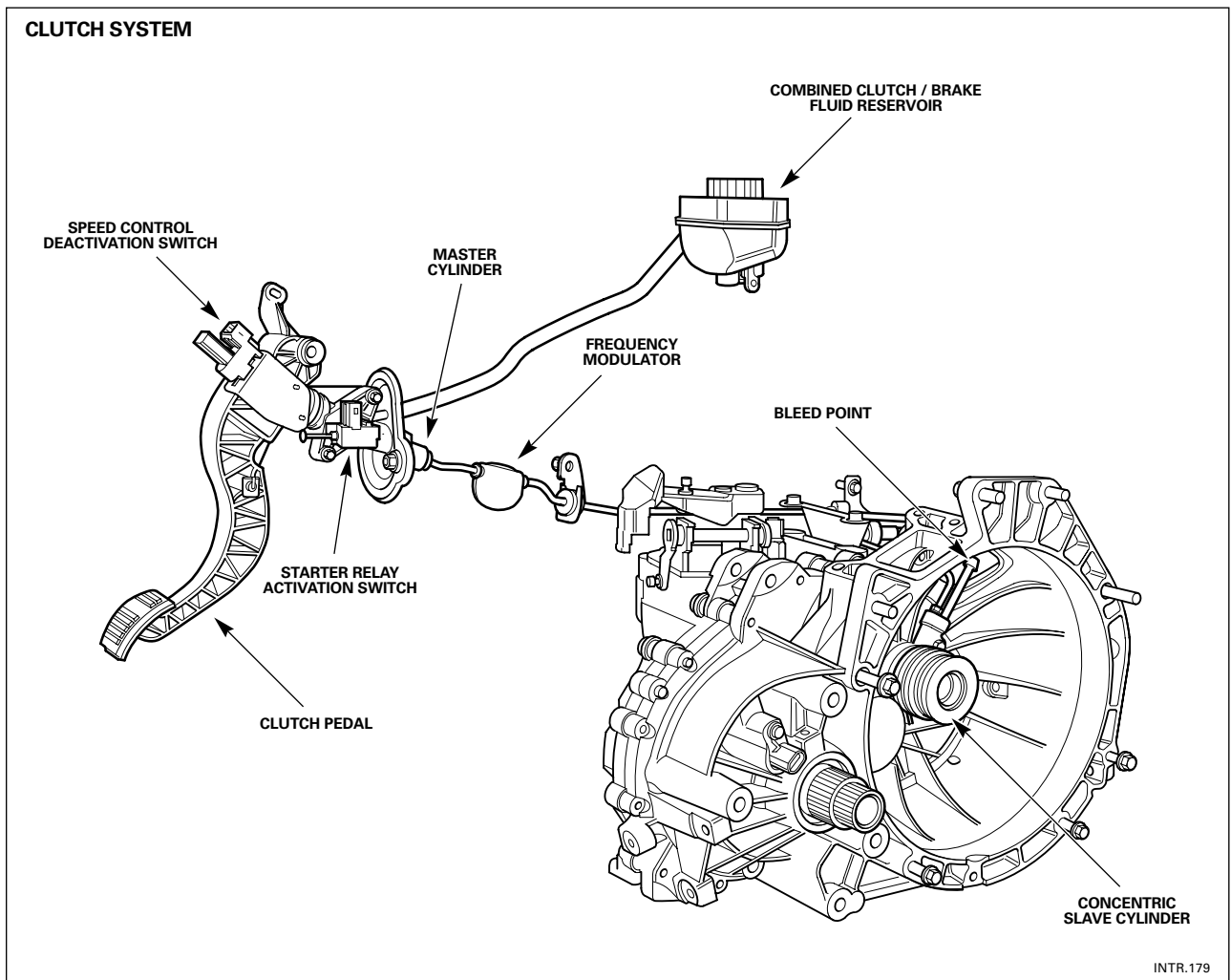

Driveline

All Wheel Drive (AWD) System

A new feature and a first for Jaguar is the Visteon all wheel drive (AWD) system. The AWD system provides superior traction and handling characteristics that will appeal to a younger driver.

AWD uses an epicyclic center differential with a viscous coupling. A drive split of 40% / 60% is provided, with 40% split to the front road wheels and 60% to the rear wheels.

AWD Unit

- The AWD unit is a two-piece aluminum unit weighing 25.9 kg.
- Oil quantity is 0.550 – 0.600 liters of synthetic hypoid gear oil to SAE 75W-140 specifications; unit is filled for life.
- An overall ratio of 2.526:1 is achieved through two separate gearing principles:
 - Helical gear at 1.65:1
 - Hypoid bevel gear at 1.53:1

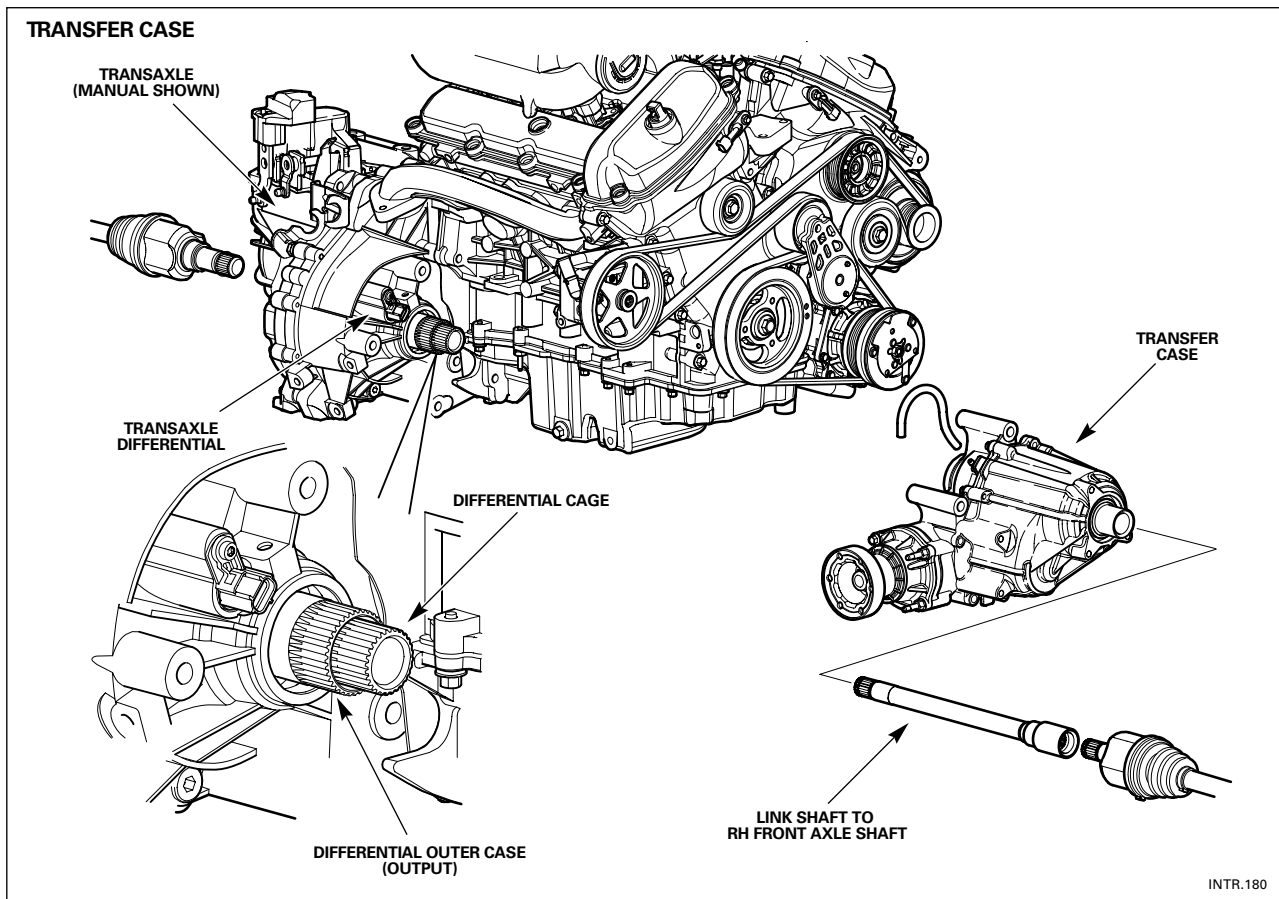

NOTES

CHASSIS SYSTEMS

Driveline (continued)

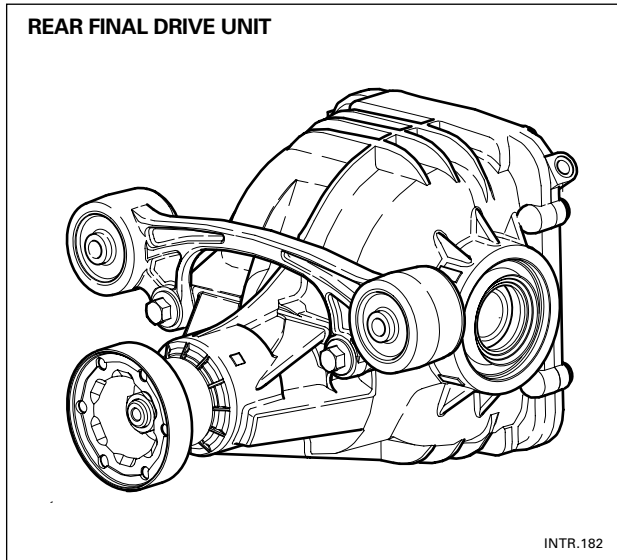

Rear Final Drive

- The assembly consists of an iron main casing with an aluminum rear cover which is sealed using RTV.
- The final drive unit weighs 26.9 kg.
- For NVH control, the final drive assembly has a 3-point isolated mounting system:
 - Two mountings at the front of the final drive unit.
 - One mounting at the rear of the assembly.
- Double isolation is provided, when combined with the rear subframe mounting bushes.
- Plug-in driveshafts are retained by C clips in the side gears.
- The unit is filled for life, with an oil capacity of 1.2 liters.
- The oil used is a synthetic hypoid gear oil to an SAE 75W-140 specification.

- This is the same thermally stable oil as used by the AWD unit.
- The rear final drive has the ratio 2.53:1.
- A compact size is achieved because only 60% of the drive is transmitted.
- The diff pinion seal replacement will be the subject of a follow-up curriculum program.

Driveshafts

Rear Halfshafts

Rear halfshafts are GKN-manufactured from a solid bar, with twin plunging CV joints. Rear driveshafts are unequal in length and have an ABS sensor ring mounted on the outboard joint. The driveshaft is retained in the final drive unit by a spring clip.

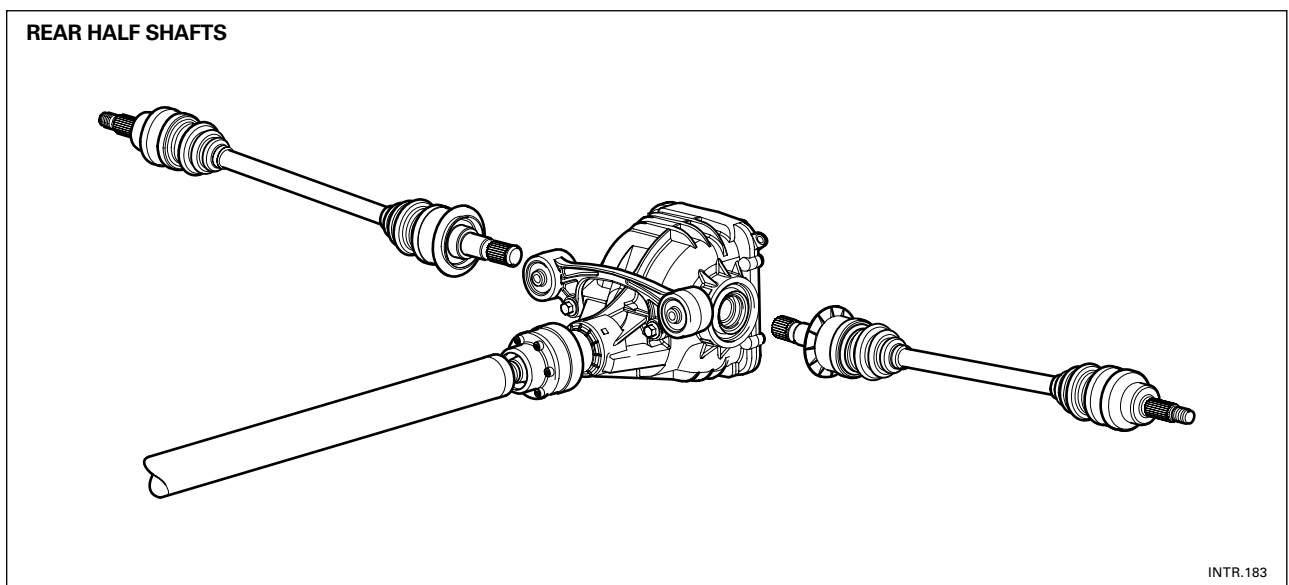

Driveshaft (Propshaft)

The GKN-manufactured driveshaft is the longest driveshaft used by Jaguar in the shortest body produced by the company to date. It consists of a two-piece steel construction using a Mag-arc welding process. The driveshaft incorporates CV joints at both ends, providing plunge capability and a Hooke's joint at the center. The center bearing is rubber isolated to the body for enhanced NVH.

One design exists for both automatic (2091.7mm installed length) and manual (2097mm installed length) transmissions.

Driveshaft Alignment A service tool for the alignment of the driveshaft (propshaft) has been developed. This tool will position the driveshaft by taking a number of measurements from points underneath the body.

Front Halfshafts

The front halfshaft is GKN-manufactured from solid Boron steel bar, with twin CV joints. The outer CV is fixed, while the inner CV is of the plunging variety. The left-hand shaft is retained in the front differential by a spring clip. The right-hand shaft is also retained by a spring clip, but is attached to a link shaft.

Special rubber gaiters on the inboard joints are fitted to withstand the heat from the exhaust system.

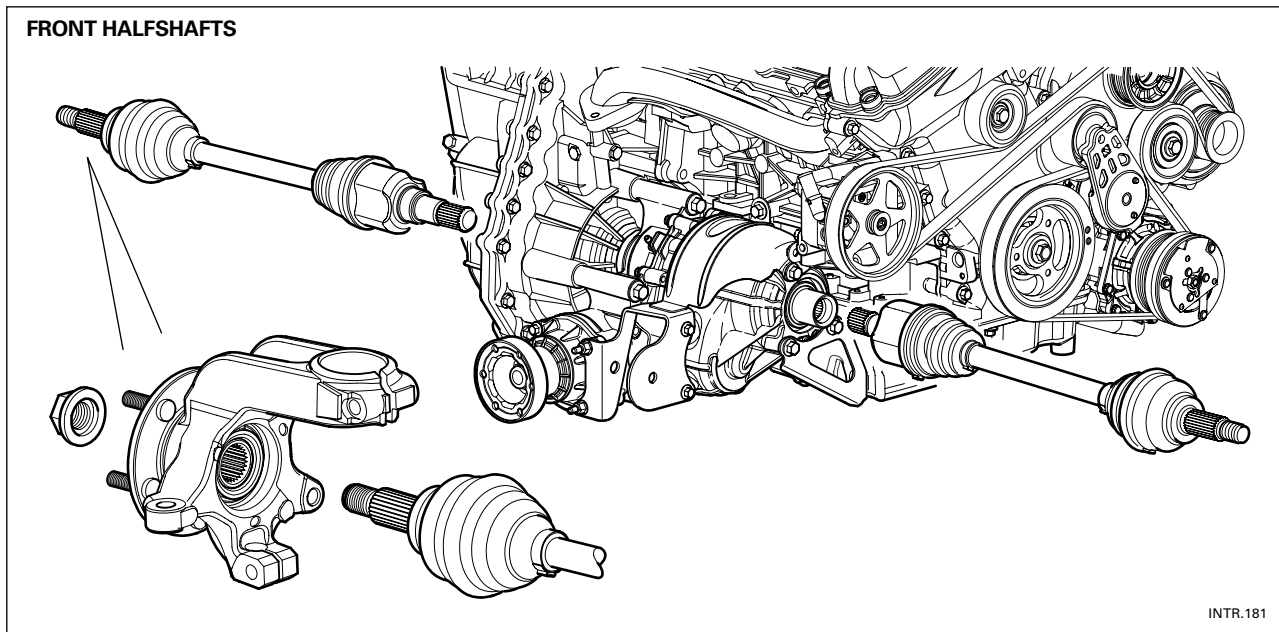

Three service tools are issued:

- An inner joint handle and fork tool
- A 200 mm limited extraction distance tool
- A link shaft removal adaptor

NOTES

INTRODUCTION TO JAGUAR



GENERAL INFORMATION

1 INTRODUCTION TO XJ/XK

2 INTRODUCTION TO S-TYPE

3 INTRODUCTION TO X-TYPE

3.1 Overview

3.2 Engine

3.3 Engine Management

3.4 Transmissions and Driveline

3.5 Suspension, Steering and Brakes

3.6 Climate Control

3.7 Electrical Distribution System

3.8 Body Systems

3.9 Occupant Protection

3.10 Task Sheets



SUSPENSION, STEERING AND BRAKES

Front Suspension

The front suspension system has been engineered to provide the Jaguar customer with the ride and handling characteristics that have become the hallmark of Jaguar Cars. The new suspension system consists of a MacPherson strut arrangement mounted on an isolated subframe, with the power steering rack rigidly mounted to the subframe assembly.

Correct orientation of the subframe rubber isolation bushes is required to maintain the correct NVH-designed characteristics. The whole subframe must be correctly aligned for the driveline angle to be maintained. This state is achieved by using a multipurpose hydraulic lift with special adaptors. Checks on subframe and engine alignment are achieved using an alignment gauge, which is provided as a service tool.

The suspension system has antidive and antisquat characteristics built in to the suspension geometry.

There is no adjustment for castor or camber; tracking is the only adjustment available.

Jacking must be carried out only on recognized body location points.

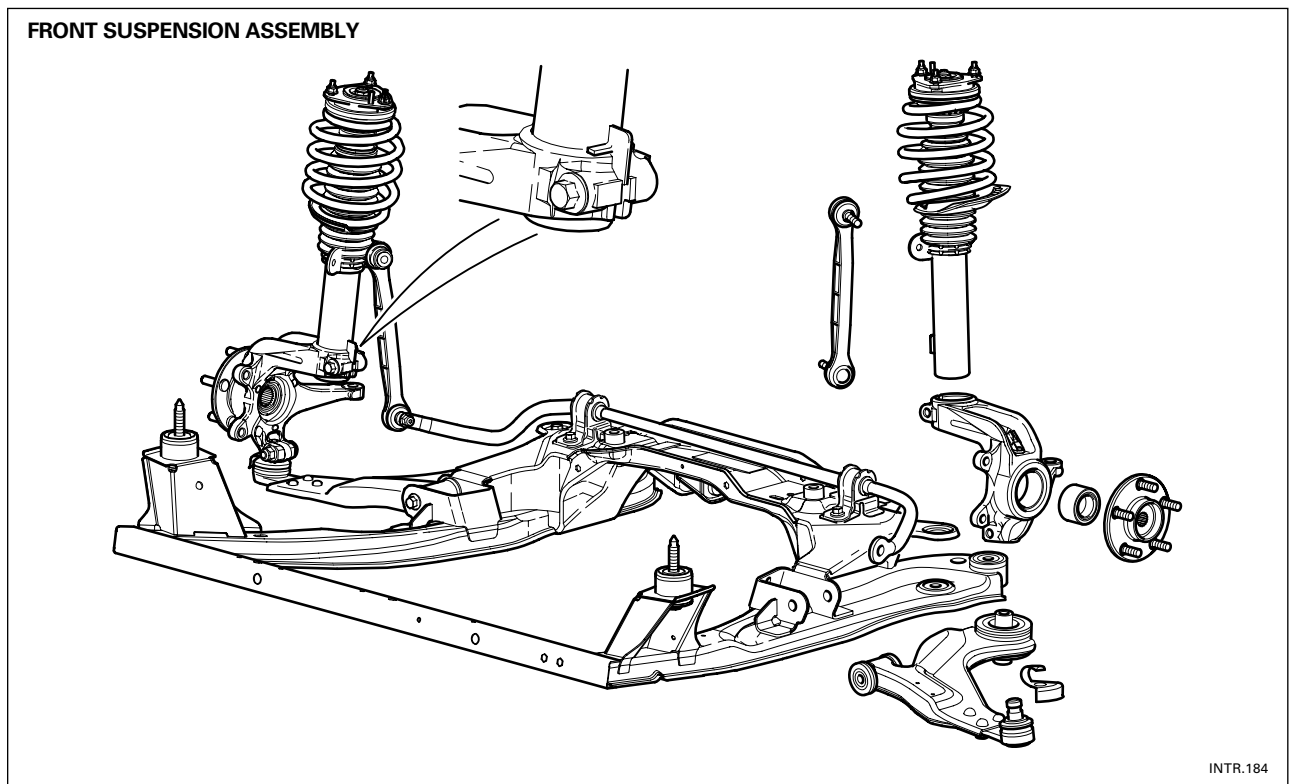

NOTES

Rear Suspension

The rear suspension system consists of a multilink coil spring system with a subframe that provides double isolation for the driveline. The Bilstein damper units are inclined to the body in white (BIW) and consist of a single tube with a 46 mm piston element.

There is no adjustment for castor or camber; tracking is the only adjustment available. The suspension system has antidive and antisquat characteristics built in to the suspension geometry.

Correct orientation of the subframe bushes is required, and the whole subframe must be aligned for the correct driveline angle to be maintained.

Jacking must be carried out only on recognized body location points, not on the suspension assembly (refer to JTIS).

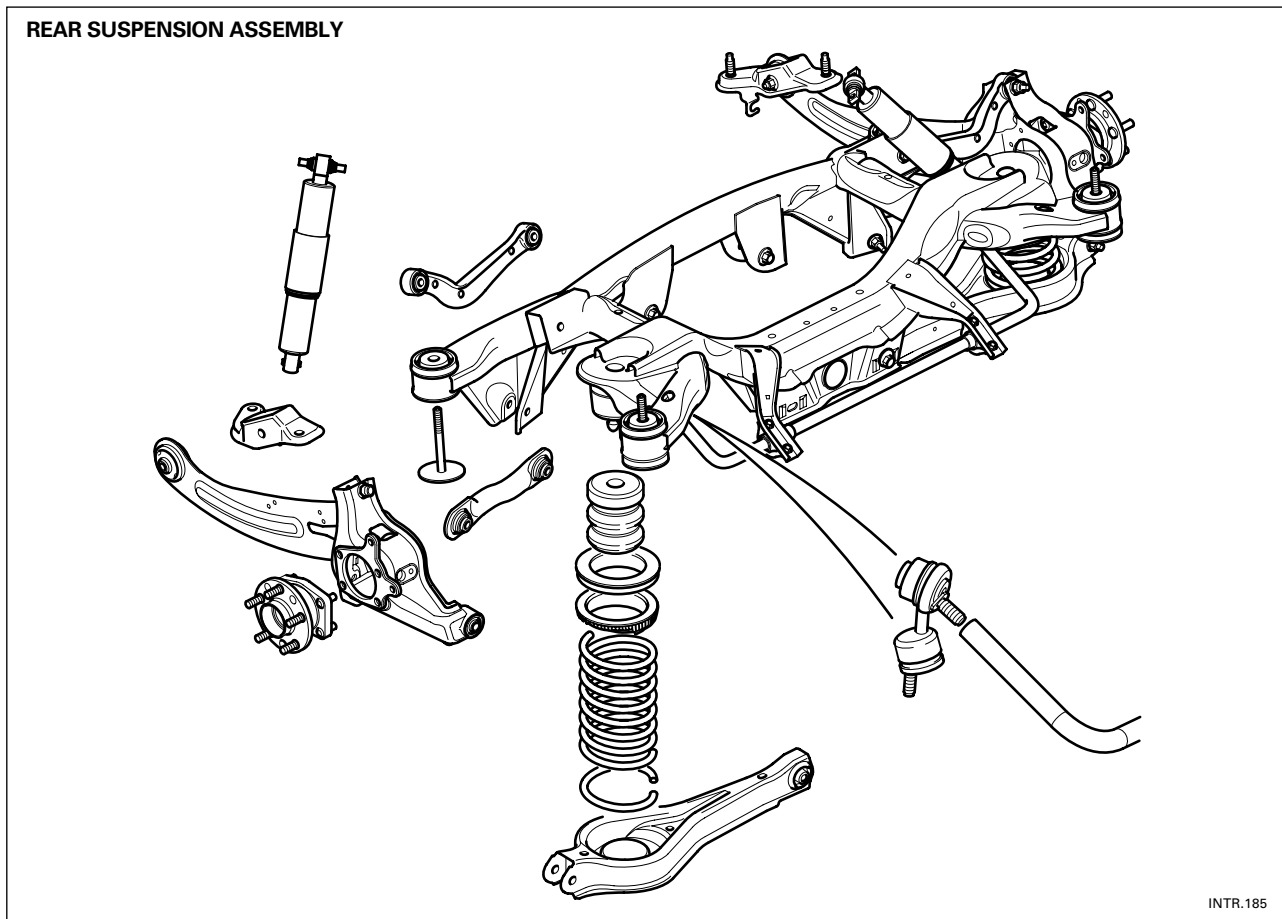

NOTES

SUSPENSION, STEERING AND BRAKES

Power Steering System

The Servotronic power steering system operates using a conventional hydraulically-operated rack and pinion equipped with a rotary valve and added electronics to control the system's hydraulics. This system provides the driver with steering assistance proportional to the vehicle's speed:

- full hydraulic power assistance is provided at low vehicle speeds, for example when parking the vehicle
- hydraulic steering assistance is gradually reduced as the vehicle speed increases, allowing the driver a precise feel of road contact

Road speed as measured by the electronic speedometer is fed to a microprocessor in the instrument cluster. The microprocessor analyzes the signal and transforms it into a current pulse which is fed to the electro-hydraulic transducer. On the basis of this pulse the transducer, which is directly attached to the rotary valve housing, controls the hydraulic reaction of the rotary valve, which determines the amount of torque the driver has to apply to the steering wheel at various vehicle speeds.

A further advantage of the Servotronic system is the fact that the oil pressure and flow are never reduced and can therefore be utilized immediately in emergencies where sudden and unexpected steering corrections become necessary.

Depending on vehicle specification, the steering is electronically programmed at vehicle production to compliment the characteristics of either the 16 or 17 inch wheels. This provides a tuned balance of the vehicle's steering to befit the size of the wheels.

The power steering pump is mounted to the engine and is driven by the accessory belt. The pump provides a constant flow rate of 8 liters per minute and has a maximum pressure of 110 bars. The fluid reservoir incorporates a 10 micron internal filter to ensure cleanliness of the system.

Steering Rack

The steering rack is a compact unit, mounted rigidly to the subframe, which from lock-to-lock requires 2.6 steering-wheel turns. The rotary motion of the steering wheel is transformed by the pinion into an axial motion of the rack. The tie rods, which are attached at each end of the rack, transmit the motion to the wheel knuckles.

The steering rack is a variable ratio design, providing ease of parking maneuverability while maintaining the on-center steering precision required at high vehicle speeds.

A heatshield is installed to protect the steering rack and other components in the bulkhead area from exhaust temperatures.

NOTES

STEERING SYSTEM ASSEMBLY

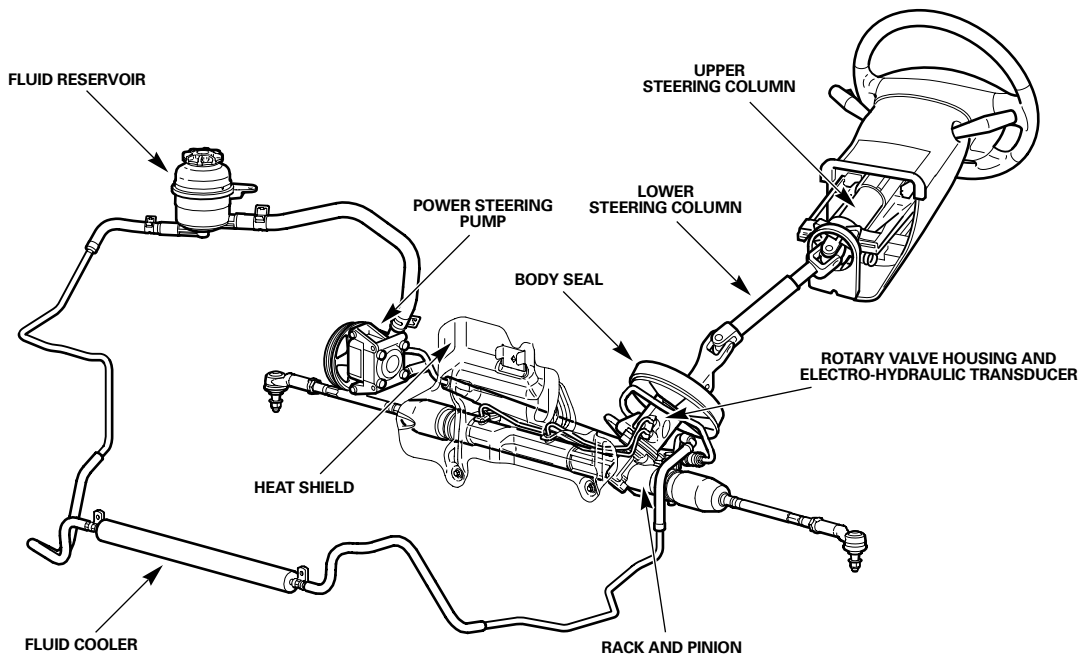

INTR.186

NOTES

SUSPENSION, STEERING AND BRAKES

Anti-lock Braking System (ABS)

The anti-lock braking system (ABS) is a four channel system having independent inputs from all four wheels. ABS is controlled by the ABS control module (ABSCM) which monitors signals from the wheel speed sensors to calculate the brake slip and the acceleration and deceleration of individual wheels. When the brake pedal is depressed, and the ABSCM detects incipient wheel lock-up from the incoming signals, it triggers the recirculation pump inside the hydraulic modulator and the solenoid valves for the wheel(s) concerned. Brake pressure is then modulated to increase/decrease or remain constant at the wheel(s) concerned until wheel lock-up is eliminated.

The ABS provides self-diagnosis and any malfunction within the system will be indicated to the driver by the anti-lock warning light illuminating. Should a fault develop within the ABS, the brake system will operate conventionally and with the same standard of performance as a vehicle not equipped with ABS.

Bosch Dynamic Stability Control (DSC)

Dynamic stability control (DSC) maximizes vehicle stability under all conditions. The DSC system compares actual vehicle course to that intended by the driver. If the intended course differs from the actual course because of oversteer or understeer conditions, the DSC system will brake individual wheels and reduce engine torque to bring the vehicle back to the driver's intended direction.

By using a combined yaw rate sensor and lateral accelerometer, the vehicle's rotational motion around its vertical axis and centrifugal forces generated while cornering are calculated to determine the vehicle's actual behavior.

Using additional sensors for detecting steering wheel position and road wheel speed enables the system to recognize the driver's original intentions.

If the vehicle begins to stray off the desired path, the DSC system intervenes and provides exactly the right amount of metered brake pressure at the correct brake caliper. Torque reduction can also be requested to assist in correcting the vehicle's attitude.

Oversteer

Oversteer indicates that the slip angle is greater at the rear than the front; the vehicle takes a smaller cornering radius than that prescribed by the driver. This condition is produced when the rear of the vehicle breaks away and pushes out towards the outside curve. Under these circumstances, the DSC system will apply braking to the front road wheel on the outside of the curve.

Understeer

Understeer indicates that the slip angle is greater at the front than at the rear; the vehicle takes a larger cornering radius than that prescribed by the driver. In this situation, the front of the vehicle pushes out towards the outside of the curve. The resulting action is that the DSC system will apply brake pressure to the rear brake caliper on the inside of the curve.

Traction Control System (TCS)

The traction control system (TCS) is combined with the DSC system. The TC system optimizes road wheel traction and vehicle stability by controlling road wheel spin. It controls the spin by using either brake actuation or engine torque reduction; where possible, both may be utilized.

Individual wheel speed signals are compared against each other and against the vehicle reference speed. The TC system will then, either by using brakes or engine intervention, reduce the slip of all affected road wheels to that of the lowest wheel speed.

In order to ensure that the brakes do not overheat, traction control braking is limited to low speeds. If the TCS system dictates that the temperature threshold has been reached, engine torque reduction is implemented and braking is ceased.

It is important to remember that the TCS enhances vehicle stability under acceleration conditions only.

NOTES

INTRODUCTION TO JAGUAR



GENERAL INFORMATION

1 INTRODUCTION TO XJ/XK

2 INTRODUCTION TO S-TYPE

3 INTRODUCTION TO X-TYPE

3.1 Overview

3.2 Engine

3.3 Engine Management

3.4 Transmissions and Driveline

3.5 Suspension, Steering and Brakes

3.6 Climate Control

3.7 Electrical Distribution System

3.8 Body Systems

3.9 Occupant Protection

3.10 Task Sheets



CLIMATE CONTROL SYSTEM

Electrical System

The majority of components is made by Visteon. The climate control electrical system is an air-blend single-zone system.

Electronic Automatic Temperature Control (EATC) System

System Operation

The EATC system maintains the interior of the vehicle at the temperature selected by occupant. The heat input, air conditioning, fan speed, and air intake and distribution are adjusted automatically to maintain the desired set temperature. Automatic control (AUTO) may be overridden at any time by the use of the various control buttons, such as the blower speed control.

EATC Control Interface Panel

This interface panel is equipped with a digital display and in many cases operates on a logic similar to that of previous Jaguar climate control systems. The information shown on the panel consists of the following items:

- External temperature (permanently displayed, when system is operational)
- Blower motor speed chaplets and axis line
- Recirculation operation symbol
- Selected temperature demand
- Auto symbol
- Air distribution symbol

The EATC panel can have up to a total of fourteen push buttons. The system On/Off button is combined with a rotary control for manual blower speed operation.

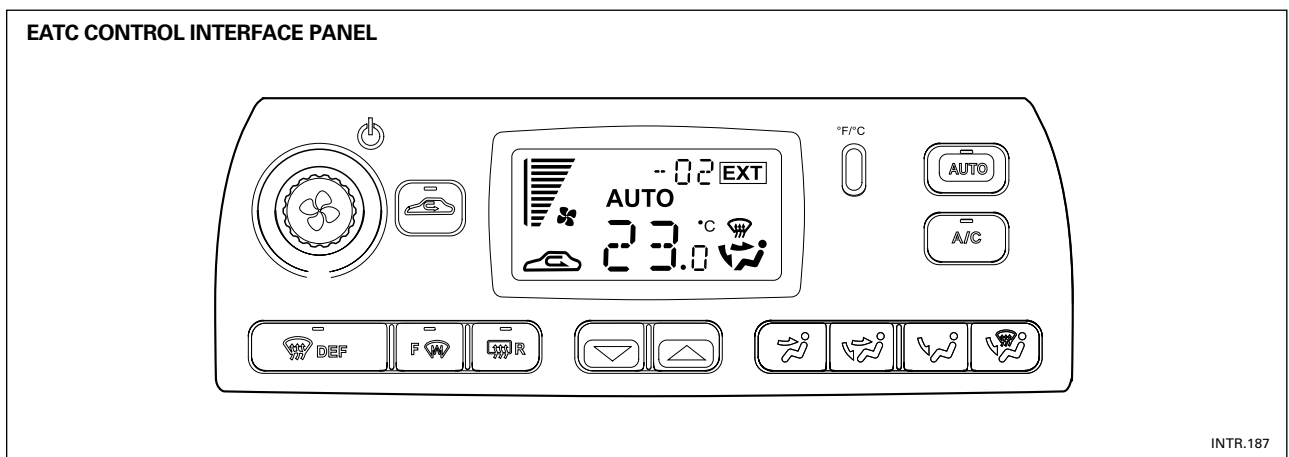

NOTES

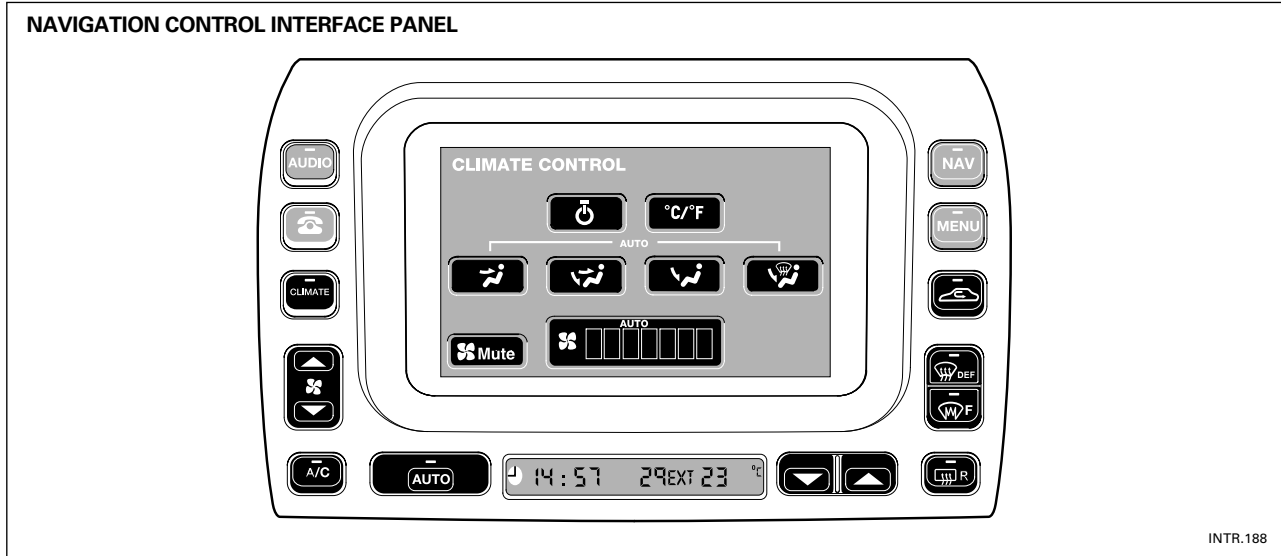

Navigation Control Panel

This panel contains a 7 inch (178 mm) touch-sensitive screen-display control system, with eleven climate control buttons, while the remaining features are selected via the navigation touch-screen display.

All the operating features for the EATC mid-line system apply to the navigation system. The main distinguishing element that differentiates the two systems is the location of the CM. On the EATC mid-line and manual low-line systems, the CM is located in the control panel assembly. However, the navigation system utilizes a remote CM because Denso, not Visteon, produces the navigation display unit.

Navigation Keys

Three levels of soft key functionality exist.

- A grayed out soft key indicates that the function is inhibited.
- A soft key with a red ring circling the circumference indicates that the feature is active.
- A soft key, not grayed out, with no red ring, indicates that the soft key is available but not active.

Keys Available

Climate Control Hard Keys

- Climate menu
- Blower speed control
- A/C ON / OFF
- Temperature demand
- Heated rear window (R)
- Heated windshield (F) (optional fitment)
- Defrost
- Recirculation
- Auto mode

Climate Control Soft Keys

- Manual fan speed indicator chaplets
- Manual air distribution selection
- System ON/OFF
- External temperature scales °C and °F
- RAM air mode
- Mute feature

INTRODUCTION TO JAGUAR



GENERAL INFORMATION

1 INTRODUCTION TO XJ/XK

2 INTRODUCTION TO S-TYPE

3 INTRODUCTION TO X-TYPE

3.1 Overview

3.2 Engine

3.3 Engine Management

3.4 Transmissions and Driveline

3.5 Suspension, Steering and Brakes

3.6 Climate Control

3.7 Electrical Distribution System

3.8 Body Systems

3.9 Occupant Protection

3.10 Task Sheets



ELECTRICAL DISTRIBUTION SYSTEM

Electrical System Architecture

Power Supplies

The Jaguar X-TYPE electrical system is a supply-side switched system. The ignition switch directly carries much of the ignition switched power supply load. Power supply is provided via three methods: direct battery power supply, ignition switched power supply, and “Battery Saver” power supply. The “Battery Saver” power supply circuit is controlled via GECM (General Electronic Control Module) internal timer circuits.

Fuse Boxes

The electrical harness incorporates a hard-wired Power Distribution Fuse Box in the engine compartment and a serviceable Central Junction Fuse Box in the front left-hand foot well. All fuses and relays (except the trailer towing accessory kit) are located in the two fuse boxes.

Battery and Transit Relay

The X-TYPE battery is located in the front left-hand corner of the engine bay and is unique to the individual model. The battery is rated 80 Ah.

The transit relay is fitted for all models and markets. Its operation is the same as that in current models. While the transit relay is fitted, the battery box lid should be stored in the trunk.

The battery is housed in a box and covered with a lid to provide protection from excessive temperatures.

The battery uses silver calcium technology, which features a specially formulated silver calcium alloy designed to operate at higher temperatures to reduce battery gassing and corrosion.

NOTE: The battery has no special requirements; however, disconnecting the battery will inevitably affect the vehicle’s electrical systems. Refer to Effect of Battery Disconnection on the following pages.

SERVICE NOTE: Make sure the battery vent tube is not kinked or crushed.

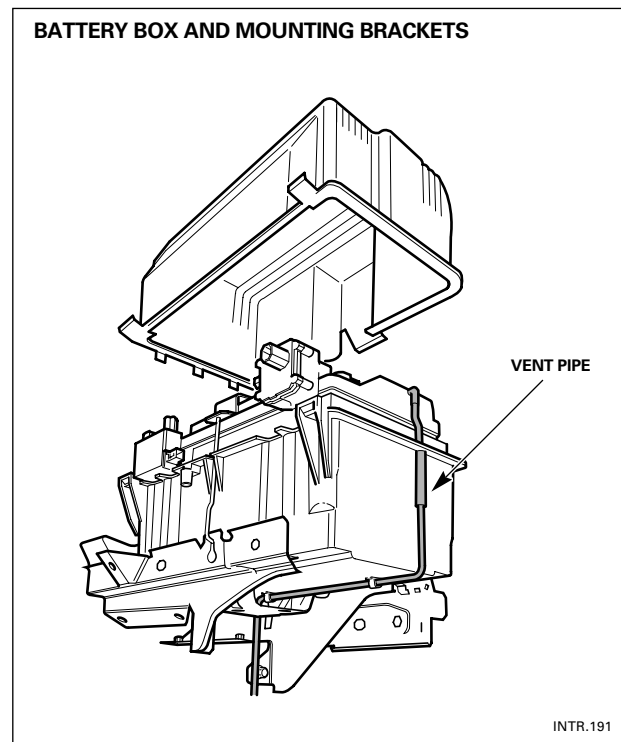

NOTES

ELECTRICAL DISTRIBUTION SYSTEM

Control Module Locations

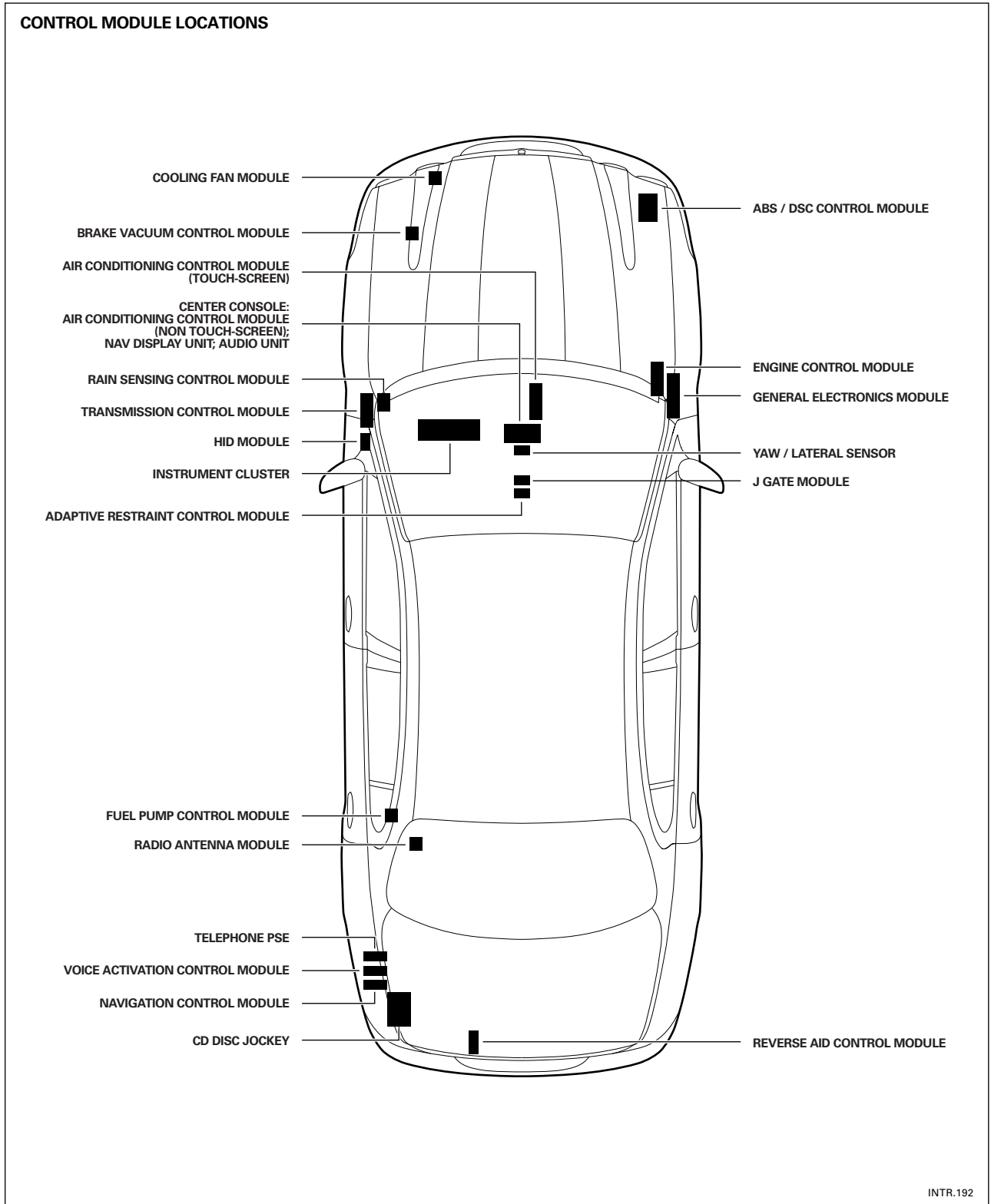

Control Module Configuration

Overview

On current vehicles, replacement control modules are programmed at the Unipart distribution centers at Baginton and Mahwah. As the number of vehicle variants increases, the number of different combinations of parameters required to configure a control module is becoming too large to allow all the options to be dealt with as a complete dataset. The system also introduces undesirable delays in repairing a vehicle. With X-TYPE vehicles, WDS software will allow replacement modules to be programmed at the dealership from the vehicle VID block.

Configuration Procedure using WDS

The operator should select the Vehicle Configuration application tab followed by Programme New Module.

- The screen will display a list of configurable modules.
- When the operator selects the appropriate module, the WDS will determine the configuration requirements and read the appropriate data from the vehicle VID block.
- The WDS will then configure the module accordingly.
- The WDS will then display the Dealer Option screen and the operator should complete the configuration by selecting the appropriate dealer fit and customer options.

Configuration of the ECM

The exception to the above procedure is when the VID block itself needs to be reprogrammed. This situation would arise if a new ECM was fitted. The procedure would be as follows:

- The operator should select the Vehicle Configuration application tab followed by Programme New Module and ECM.
- The WDS will check the VIN stored in the Instrument Cluster and compare this with the VIN entered by the operator at the start of the session. If these are different, the operator will be given a VIN mismatch warning and will be asked if the manually entered data should be used.
- If the operator selects No, a keyboard will be displayed and the VIN can be re-entered manually.
- If the operator selects Yes, the calibration files and VCATS data stored by WDS relating to that VIN will be displayed for the operator to check and confirm.
- The calibration procedure will then take place after which the operator will be told to cycle the ignition.
- The appropriate Dealer Option screens will be presented for the operator to select the appropriate dealer fit and customer options.
- Finally, the VID block programming will be carried out where the configuration details from the other modules and the vehicle VIN are stored in the VID block. At this stage, the PATS code alignment to the Instrument Cluster will be carried out without any input required from the operator.

Programming Existing Modules

The Vehicle Configuration application tab gives the operator the option of configuring an existing module as well as a new module. This procedure will only be provided for modules that require flash programming or software updates. If this option is selected, only a list of re-programmable modules will be displayed.

NOTES

ELECTRICAL DISTRIBUTION SYSTEM

Multiplexing

The X-TYPE is the most complex Jaguar vehicle to date in terms of both the number of harness variants and the possible combinations necessary to achieve give vehicle specifications. The most significant deviation from the distribution system used for other Jaguar models is the introduction of optical fiber cables to accommodate the transfer of very high-speed, real-time audio data.

The optical fibers provide an optical network that interfaces to the SCP network via the audio unit. Refer to D2B Network for detailed information.

NOTE: The optical network currently uses a transfer protocol known as D2B. Although this protocol may change in the future, the optical network will be referred to as “D2B” throughout this and other Jaguar technical publications.

SCP, CAN and Serial Data Link (ISO 9141) Networks

The Standard Corporate Protocol (SCP), Controller Area Network (CAN) and Serial Data Link (ISO 9141) networks are configured in a similar way to current Jaguar models to accommodate different data types and flow rates as required for various vehicle features. Refer to the following table.

Network	Communication Between	Speed
CAN	Engine, Transmission, Braking System	500 K baud
SCP	Lower speed body systems	41.6 K baud
Serial Data Link (ISO 9141)	Data Link Connector and ECM; Control modules with self-diagnostic capability not connected to CAN or SCP	10.4 K baud
D2B	In-Car Entertainment	5.6 M baud

NOTES

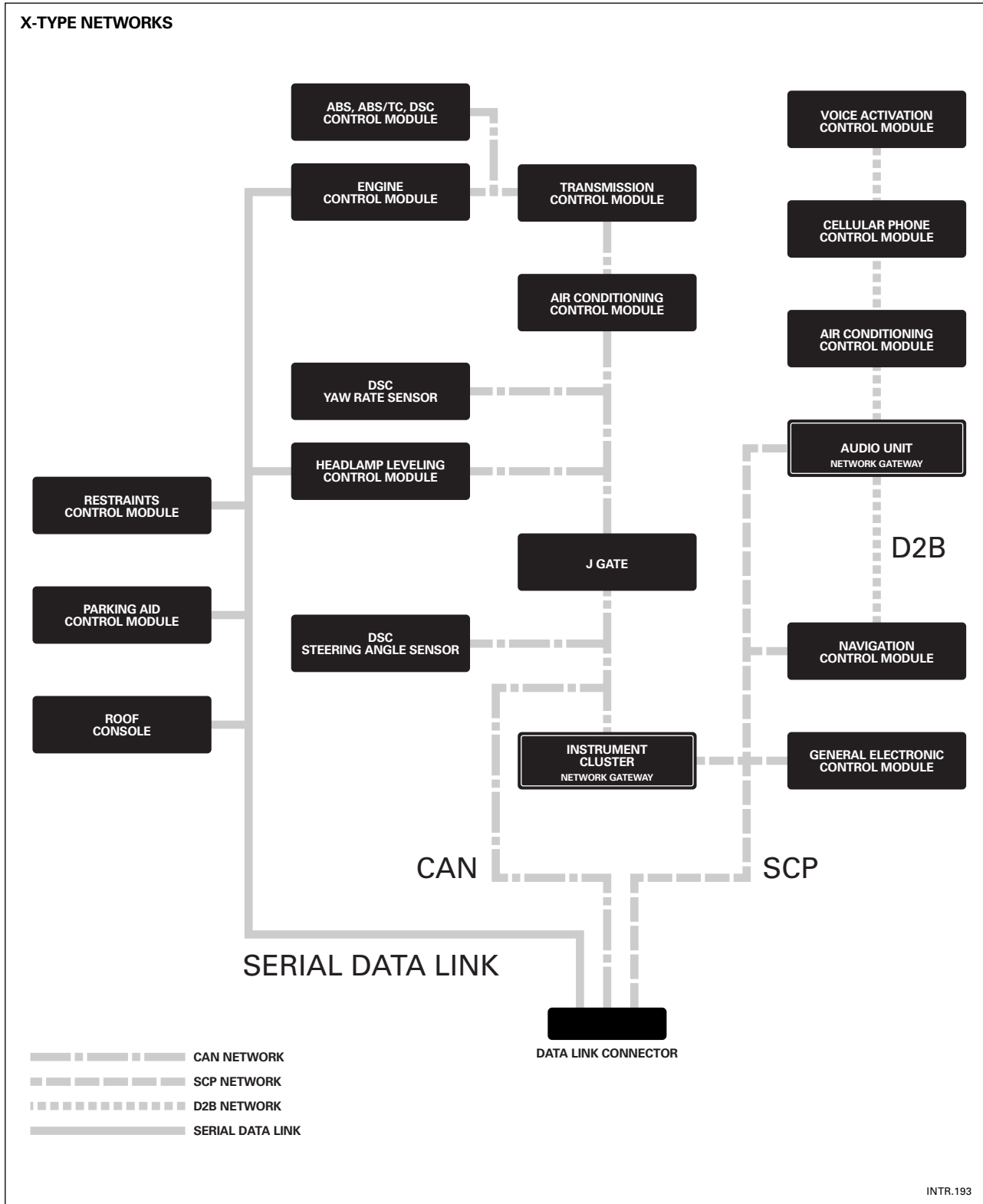

ELECTRICAL DISTRIBUTION SYSTEM

Multiplexing (continued)

D2B Network

Network Components

Optical fiber The fiber comprises a 1mm (0.039 in.) polymer core with a 3.5mm (0.137 in.) diameter outer protective jacket. The fiber facilitates the transport of data, in the form of pulses of light which are too fast to be seen by the eye, at a data bit rate of approximately 5.5M bits per second.

Wake-up wire The wake-up wire comprises copper wire configured in a star-like arrangement that connects to a single pin on each of the modules.

- The audio unit sends a wake-up command (an electrical pulse) via the copper wire to initialize the slave module(s).
- The wake-up pulse is sent when the ignition key is turned to position “1”.
- The pulse triggers slave modules to look at the preceding module for a “light signal” (originated by the audio unit) and to participate with the audio unit in network initialization.
- At the end of this initialization procedure, the modules are ready for full network operation.

NOTE: Any malfunction during the initialization stage will cause a DTC to be stored by the audio unit. The D2B Network will then shut down for the remainder of that key cycle.

Master module The master module is the audio unit; it manages the D2B network and provides the gateway to the SCP network.

Slave module(s) A slave module is any other system module that is connected to the D2B network and includes:

- Navigation control module
- Cellular phone control module
- CD autochanger
- Voice activation control module

Handling

Special care should be taken to avoid damage or contamination when handling or working on the vicinity of fiber optical cables and connectors.

NOTE: Damage or contamination includes scratches to the cable ends and pollution caused by dust, dirt or oil.

CAUTION: When handling optical fibers, cleanliness is of paramount importance. The fiber ends should not be touched even with clean bare hands, as the natural oils deposited from the skin may penetrate the fiber or may cause dirt to adhere to the fiber end.

System malfunctions and unnecessary warranty claims can be minimized by following these guidelines:

- After disconnection of any cables, carefully install an appropriate dust cap to protect the mating face of the connectors from damage or contamination.
- Avoid introducing tight bends (less than 25mm radius) or kinks into the optical fiber during service or repair. Tight bends or kinks could:
 - Impair system operation
 - Cause immediate system failure
 - Cause future system failure
- Avoid excessive force, strain or stress on the fibers and connectors, especially permanent stress after reinstallation.



INTRODUCTION TO X-TYPE

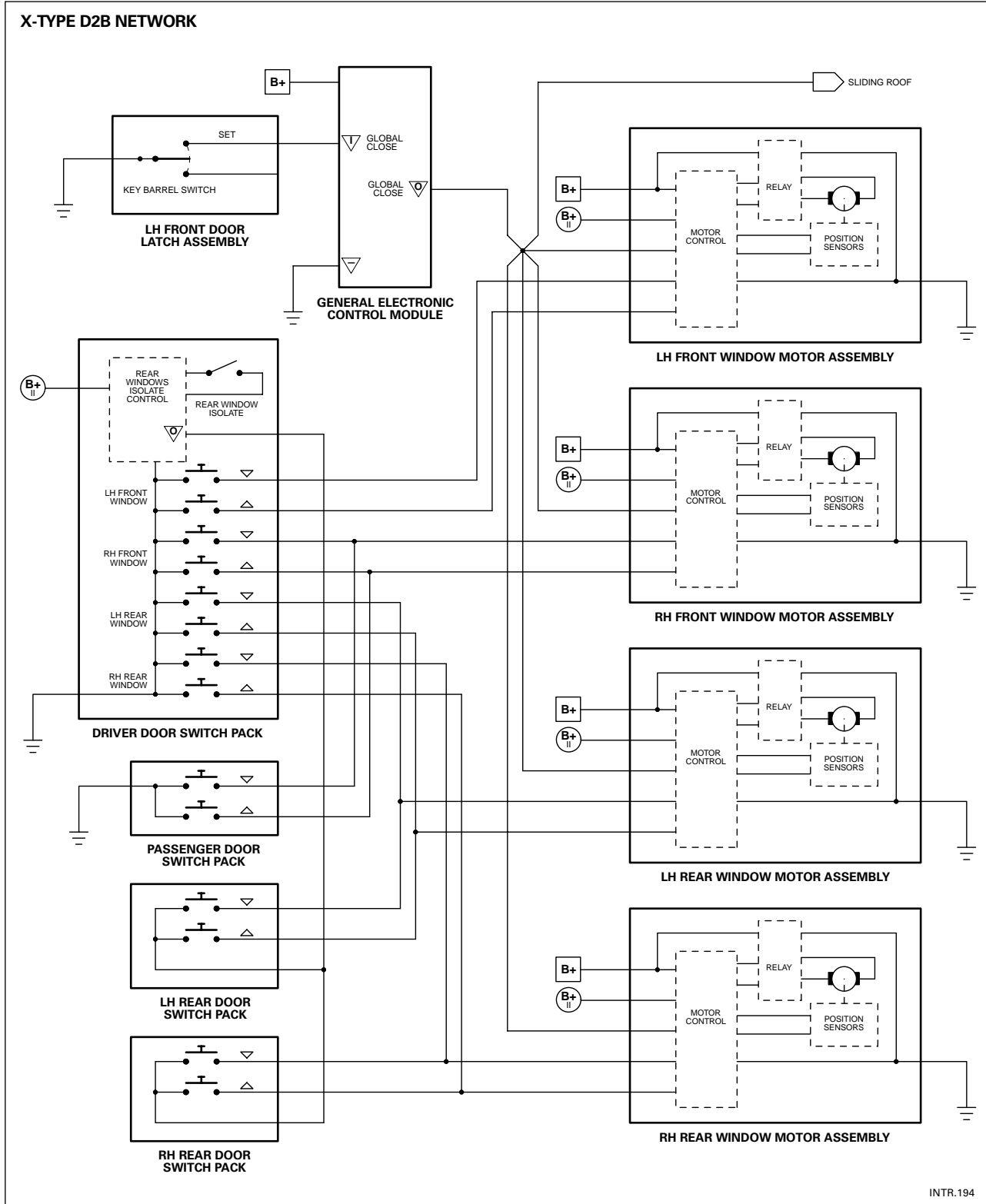

INTR.194

INTRODUCTION TO JAGUAR



GENERAL INFORMATION

1 INTRODUCTION TO XJ/XK

2 INTRODUCTION TO S-TYPE

3 INTRODUCTION TO X-TYPE

3.1 Overview

3.2 Engine

3.3 Engine Management

3.4 Transmissions and Driveline

3.5 Suspension, Steering and Brakes

3.6 Climate Control

3.7 Electrical Distribution System

3.8 Body Systems

3.9 Occupant Protection

3.10 Task Sheets



BODY SYSTEMS

Exterior Lighting

Depending on market and vehicle specification, X-TYPE has only two major deviations from a standard exterior lighting arrangement: autolamp and high-intensity discharge headlamps (complete with automatic headlamp leveling).

Exterior lighting is activated by the main lighting switch and, where appropriate, the left-hand column stalk switch (high beam).

NOTE: Due to the 'warm-up time' experienced with xenon lamps, the low beam lamp is not used for the headlamp flash feature; the high beam is used instead.

Switching is via allocated fuses and relays, with the exception of the turn signal lamps/hazard warning lamps, which are controlled by the general electronic control module (GECM).

Main Lighting Switch

The main lighting switch assembly comprises:

- Rotary switch
- Dimmer switch
- Trip computer switchpack

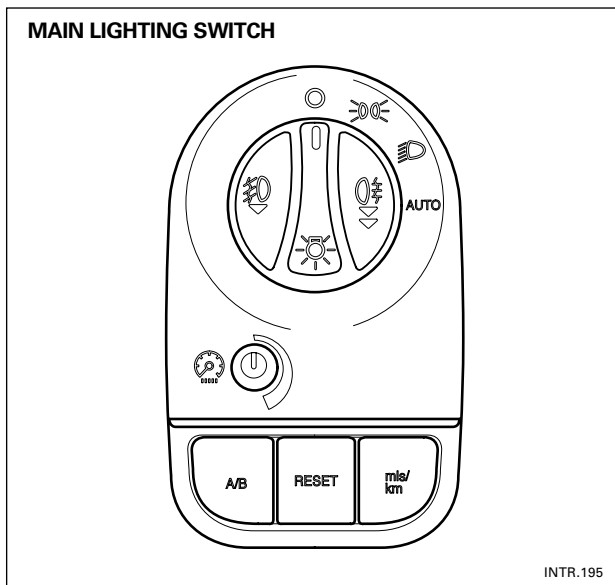

The rotary switch is used to activate the following:

- Side lamps
- Headlamps
- Autolamp
- Front fog lamps
 - The lamps are activated when the rotary switch is 'pulled' to its first position, provided the side lamp or headlamp position is also selected.
- NOTE:** The front fog lamps will not operate if main beam is selected.
- Rear fog lamps
 - The lamps are activated when the rotary switch is 'pulled' to its second position, provided the rotary switch is not at the OFF position.
 - NOTE:** The front fog lamps will automatically operate when the rear fog lamps are selected, provided the main beam is not selected.

NOTES

Halogen Headlamps

NOTE: After approximately 5 minutes a noticeable fall in lamp output may be observed. The effect is due to a voltage boost feature that has been introduced.

Autolamp (where applicable)

A sensor monitors ambient lamp levels and provides feedback that will permit the automatic control of the side lamps and low beam headlamps where appropriate, providing:

- The ignition key is at position II
- The AUTO option on the main lighting switch is selected

NOTE:The sensor is integral to the interior rear view mirror (but is only available when the electrochromic mirror is fitted), therefore obstruction of the sensor, including failure to keep the windshield clean, will affect the operation of the lamps.

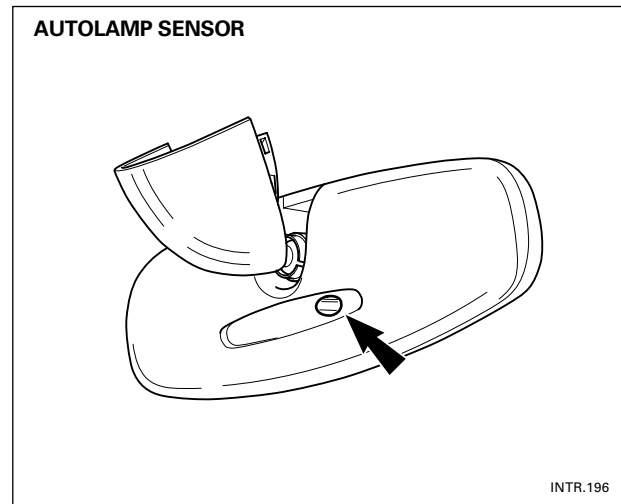

The sensor is calibrated to monitor ambient light levels:

- Detection of darkness for 2 seconds continuously, will cause the low beam and side lamps to be activated
- Detection of daylight for 15 seconds continuously, will cause the exterior lighting to be extinguished

NOTES

BODY SYSTEMS

Exterior Lighting

High Intensity Discharge (HID) Headlamps

The High Intensity Discharge Headlamp System provides illumination approximately twice as bright as a standard H1 halogen bulb. Because of this level of brightness, an automatic headlamp leveling system has to be incorporated to prevent dazzling oncoming drivers.

HID headlamps are used only for dip beams. Main beams remain halogen bulbs.

The headlamp burners consist of a tube filled with xenon gas with an electrode at either end. When the lamps are switched on, an electric charge is applied across the electrodes. After a brief high current phase, the lamp output is regulated to 35 W.

The lamp wear is so minimal that the xenon burner is designed to last the life of the vehicle.

NOTE: The system is not a dealer fit option.

WARNING: CARE SHOULD BE TAKEN WHEN WORKING ON THE SYSTEM. XENON LAMPS CAN GENERATE ELECTRICAL VOLTAGES OF UP TO 35 kV; SUITABLE SAFETY PRECAUTIONS MUST BE OBSERVED.

WARNING: DISCONNECT LIGHTING UNITS FROM THE VEHICLE HARNESS BEFORE PERFORMING ANY WORK ON THE HID SYSTEM.

The high-intensity discharge headlamp assembly comprises:

- Low beam lamp (xenon)
- High beam lamp (halogen)
- Side lamp
- Turn signal lamp
- Xenon lamp control module
- Igniter
- Headlamp leveling motor

Vehicles fitted with the high-intensity discharge lighting system use xenon lamps for the low beam instead of standard halogen lamps.

- The functionality of the low beam remains unchanged
- The high beam, turn signal and side lamps are all conventional lamps

NOTE: Due to national legislation, vehicles equipped with xenon lamps require the installation of Automatic Headlamp Leveling and Headlamp Cleaning System.

NOTES

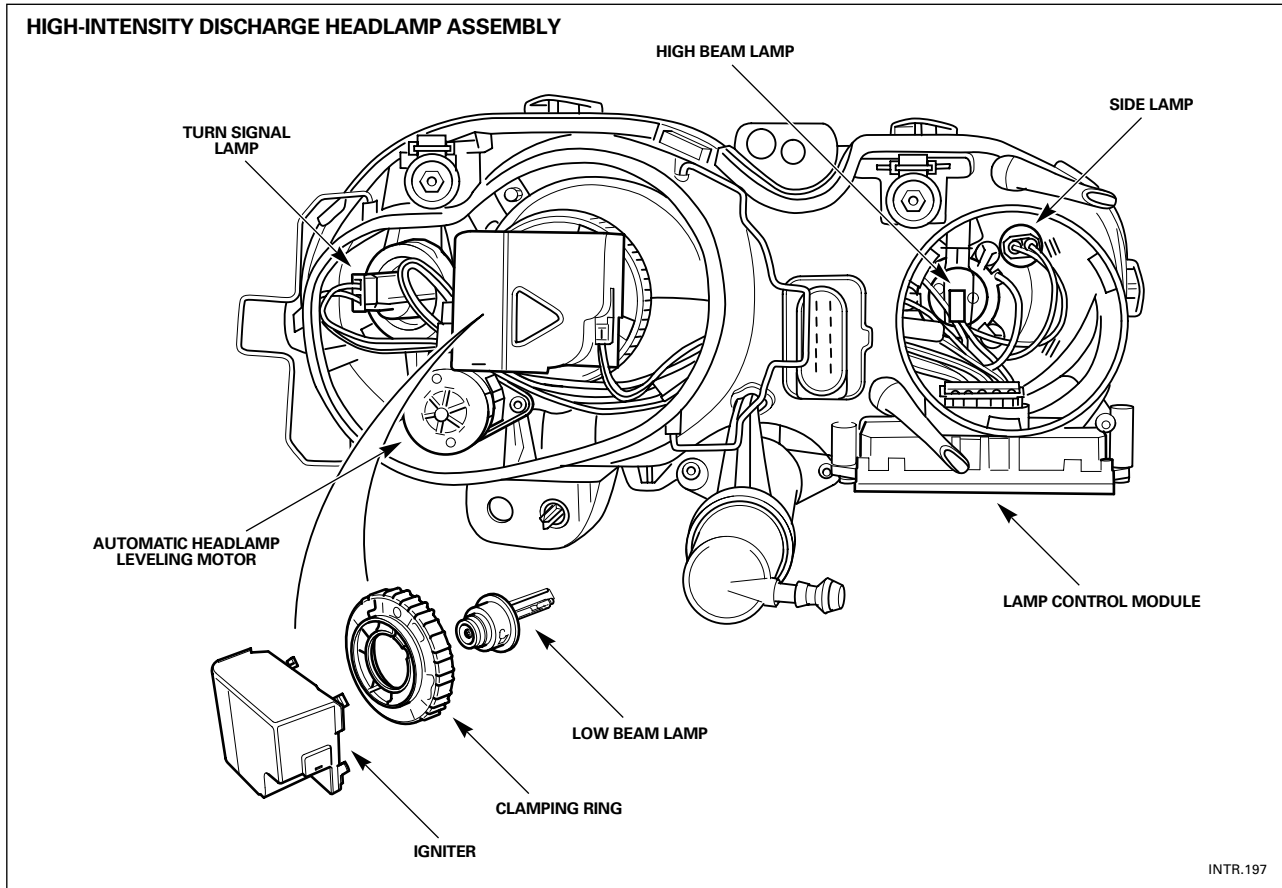

INTR.197

Xenon Lamp

The 35 watt xenon lamp produces a beam with a intensity that is approximately three times that produced by a conventional lamp of the same wattage.

The chamber contains xenon gas and a mixture of metal halide salts. High voltage (typically 20kV) ignition is provided by the xenon lamp control module and an arc forms in the chamber as the gap between the two electrodes is bridged. After ignition there is a warm-up period of approximately three seconds during which the metal-halide salts evaporate. This brief excess-current phase is followed by stabilization of the arc and the regulation of the lamp output at 35W by the control module.

NOTE: Unlike conventional lamps, xenon lamps do not deteriorate and so should last the lifetime of the vehicle.

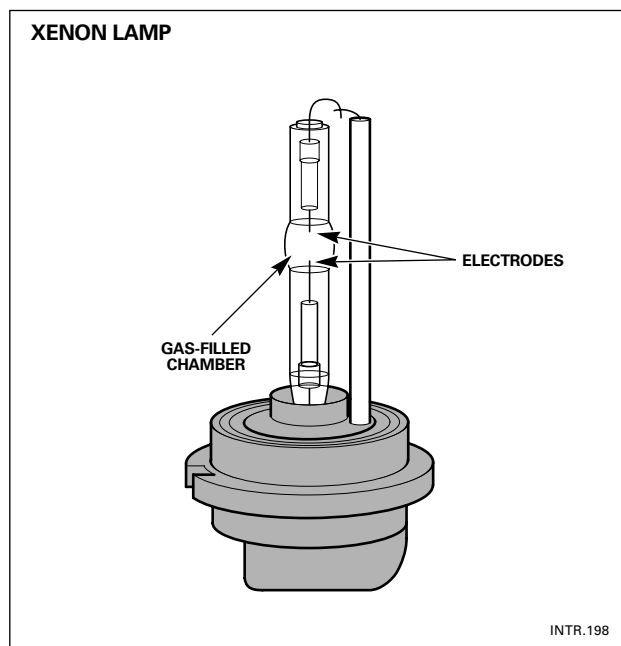

INTR.198

BODY SYSTEMS

Exterior Lighting

High Intensity Discharge (HID) Headlamps

Automatic Headlamp Leveling

The system comprises:

- Front-axle level sensor assembly
- Rear-axle level sensor assembly
- Headlamp leveling module
- Left-hand headlamp leveling motor
- Right-hand headlamp leveling motor

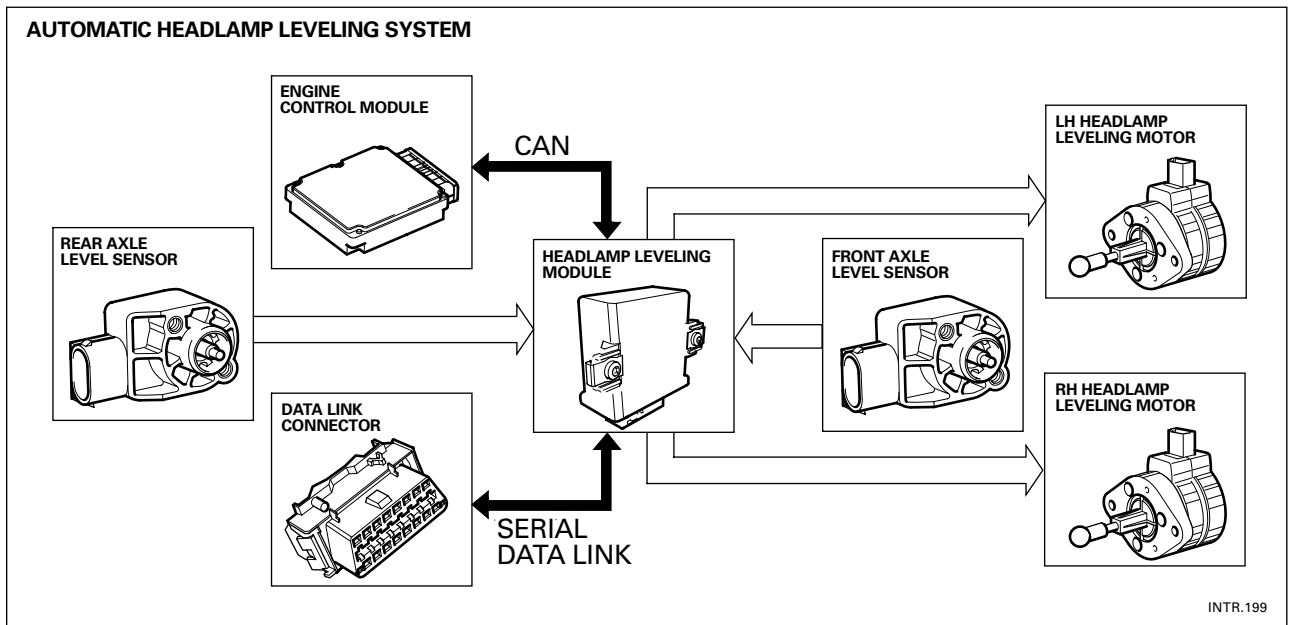

Automatic headlamp leveling is operational when the main lighting switch is set to the headlamp, rear fog lamp or autolamp position and the ignition key is at position II.

The headlamp leveling module is located at the left-hand side of the instrument panel and is accessible after removing the side and lower panels.

The axle level sensors are inductive devices that respond to the vertical position of the vehicle and supply feedback signals to the module. The module processes the data and supplies appropriate signals to the headlamp leveling motors causing the position of the headlamps to be adjusted accordingly.

NOTE: After disconnecting any element of the automatic headlamp leveling system, recalibration will be necessary using WDS.

NOTES

Anti-Theft System

Anti-theft options depend on market specification and include a perimeter alarm system and a passive anti-theft system (PATS). The X-TYPE incorporates the following, either as standard or dealer installed options:

- Key barrel on driver's side only
- Encrypted instrument cluster/engine control module immobilization system, controlled by the ignition key transceiver/transponder
- Radio frequency remote transmitter integrated into main key
 - Four control buttons (lock, unlock, luggage compartment lid release, headlamp convenience/panic)
- Central locking by key, remote transmitter and interior handle
- Auto-locking
 - Drive-away locking
 - Auto-relock
- Perimeter alarm of doors, hood and luggage compartment lid
- Panic alarm – remote transmitter operated
- Integrated security system indicator lamp (dual function – indicates vehicle alarm system armed and PATS fault codes)
- Two-stage unlocking
- Separate security horn or battery backed security sounder (market dependent)

Definition of terms:

- Auto-locking (drive-away locking) – the doors will lock automatically when the vehicle is driven away, at a speed in excess of 7 km/h (4 mph)
- Auto-relock – the vehicle is centrally locked and armed following a remote control unlock if no door was opened or if the ignition key remained at position '0' for 45 seconds
- Two-stage unlocking – a security feature where only the driver's door unlocks under normal operation of key or transponder remote (passenger door can be unlocked with a second unlock operation)

The perimeter alarm system consists of several core components:

- General electronic control module (GECM)
- Vehicle horn
- Hood ajar switches
- Door ajar switches
- Luggage compartment lid ajar switch
- Security system indicator lamp

Market dependent components include:

- Security horn or battery backed sounder

The security system is armed by locking the vehicle using the driver's door lock or by pressing the lock button on the key fob transmitter.

Once armed (25 seconds after locking), any of the following will trigger an alarm:

- Opening a door/hood/luggage compartment lid
- Using an invalid PATS ignition key

When an alarm is in progress, the turn signals flash and the vehicle horn sounds. Where fitted, the security horn or battery backed sounder sound in conjunction with the vehicle horn.

The security system can be disarmed by unlocking the driver's door lock, pressing the unlock button on the key fob transmitter, or turning a valid key in the ignition.

NOTES

BODY SYSTEMS

Power Windows

The power window motor electronics each monitor an integral hall effect sensor feedback signal to determine when the normal travel of the motor is limited.

When the vehicle power supply is disconnected, the antitrap and one-touch up features will no longer function when the power supply is restored.

The initialization procedure must be carried out to restore operation.

Power Window Initialization

- Lift and hold the window switch in the up direction until the window seats completely. Continue to hold the switch for a further 2 seconds.
- Release the switch and then lift and hold it again for a further 2 seconds. This procedure ensures that the window is fully seated into the seal.
- Press the window switch to lower the window to its fully open position.
- Verify the operation of the antitrap and one-touch up operation.

NOTE: This procedure can be carried out either from the individual window switches or from the driver's switchpack.

Thermal Overload

The window motors are protected from overheating by a thermal overload feature. If the windows are operated continuously, the thermal overload feature will operate and the window will no longer respond to the operation of the switch. The number of opening / closing cycles required to implement this feature varies depending on temperature, but it should never be less than 7. One touch up and down operation should be possible within 10 seconds with full operation resuming after a brief rest period.

Ice Mode

The windows have an ice mode feature to facilitate the closing of the windows in the event of the glass run channels being obstructed by ice. This feature is activated by the vehicle occupant as follows:

- Raise the window until the obstruction is reached. The antitrap feature will operate, lowering the window to a minimum of 50 mm below the point at which reversing was initiated (or at least 200 mm from the close position).
- Raise the window back up to the obstruction. Again the antitrap feature will operate.
- Within 10 seconds, raise the window a third time to the obstruction. This time the antitrap feature will not operate. Release the switch.
- Lift the switch again within 0.5 seconds. The window motor will now operate at its full force (250 N maximum) for approximately 12 mm of upward travel. This can be repeated several times provided that each time the switch is activated within 0.5 seconds.
- Should the 250 N force be insufficient to clear the obstruction, this insufficient force will be interpreted as system failure and the one-touch up function will be disabled. To relearn the function, the window initialization procedure will have to be performed.

Sunroof Operation

The sunroof motor module also monitors an integral hall effect sensor feedback signal to determine when the normal travel of the motor is limited.

The sunroof is not affected by battery disconnection and will not need to be initialized. However, if power is disconnected while the sunroof is actually being operated, then memory will be lost and the following initialization procedure will have to be carried out. This procedure will also have to be carried out if the sunroof motor is changed.

Sunroof Initialization

- Press the switch in the tilt position until the roof moves to the fully tilt position and stops.
- Release the switch.
- Within 5 seconds, press and hold the switch in the tilt position again. The roof will travel automatically to the fully open position, back to the fully closed position and stop.
- Verify the operation of the antitrap and one-touch features.

NOTE: If the antitrap or one-touch features stop working correctly for any reason, the roof can be reinitialized without disconnecting the battery.

To reinitialize without disconnecting the battery, run the roof panel into the tilt position and continue to press and hold the switch for 20 seconds. The roof panel will move up and down signaling memory erasure of the previous initialization.

The roof panel can then be reinitialized as described above.

NOTES

BODY SYSTEMS

In-Car Entertainment (ICE)

The entertainment systems comprise:

- Audio system:
 - Audio unit
 - CD changer
 - Steering wheel telematics controls
- Antenna
- Speakers

Specific components will vary according to vehicle and market specifications.

NOTE: The entertainment system may also be operated by spoken commands if the optional Voice Activated Control System is installed.

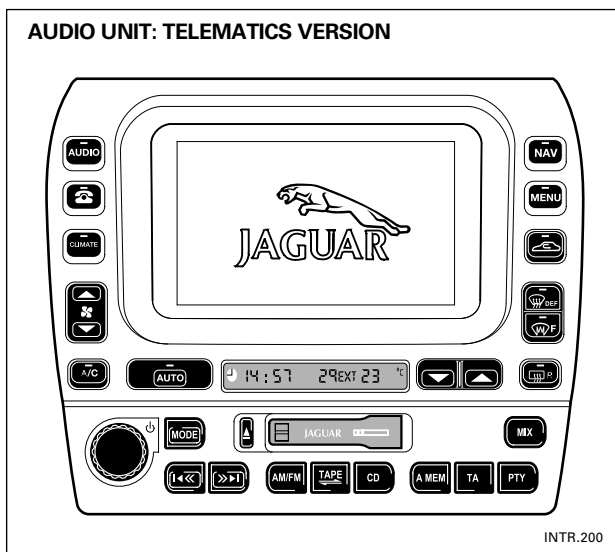

Audio Unit

Depending on vehicle specification, the audio unit is integrated with the telematics display module (telematics version) or integrated with the phone keypad and small LCD (non-telematics version).

The audio unit:

- Manages the D2B network and provides the gateway to the SCP network
- Stores diagnostic trouble codes for itself and the CD changer (where installed).

NOTE: The installation of new components within the audio system will necessitate the reconfiguration of the system using WDS.

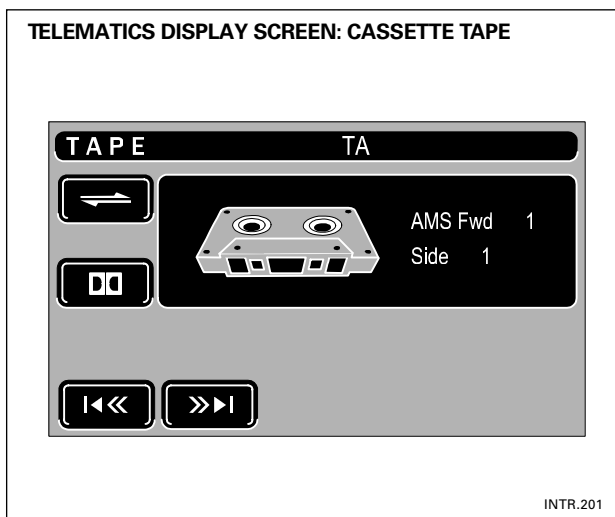

Telematics Version

The telematics version of the audio unit is integrated with the telematics display module and comprises:

- Radio cassette
- Integral amplifier (4x 35W output)

NOTE: The telematics display module is used in conjunction with the audio unit to control entertainment system functions but also provides the ability for the user to control such features as climate control.

Non-Telematics Version

- The non-telematics audio unit comprises:
 - Radio cassette
 - Liquid crystal display (LCD) including clock
 - Integrated phone keypad
 - Integral amplifier (4 x 35W output)

NOTE: The non-telematics version of the audio unit is complimented by the climate control panel/module.

CD Changer

The CD changer (where installed) is:

- Located in the left side of the luggage compartment
- Operated from either version of the audio unit

Steering Wheel Telematics Control

To ensure minimum disruption to concentration when driving, limited control of audio, telephone and voice activation systems is possible using the steering wheel telematics controls.

The controls provide the following functionality:

- Answer phone call, mute, or select voice activation
- Increase or decrease volume
- Selection of radio FM, AM, tape cassette, CD and phone ready mode
- Cycle through preset radio stations, the next CD track or tape AMS (automatic music search)

Antenna

The following antennas (where applicable) are integrated into the rear window glass:

- FM element
- AM element

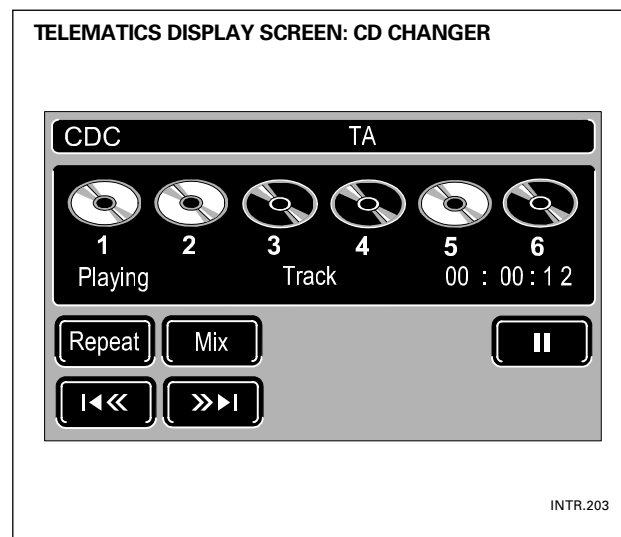
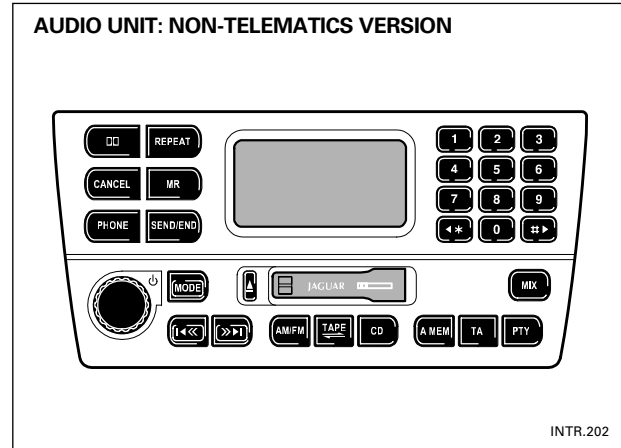

Speakers

The base audio sound system comprises:

- Four full range door speakers

The premium audio sound system comprises:

- Four lightweight mid-bass door speakers
- Four door-mounted tweeters
- Sub-woofer enclosure

BODY SYSTEMS

Navigation System

The navigation system comprises:

- Navigation control module complete with DVD reader
- Navigation data DVD
- Navigation system display module (audio unit – telematics version)
- Navigation system antenna

NOTE: The navigation system uses the Telematics Display Module (the display component of the telematics version of the Audio Unit) as the navigation system display module; refer to the appropriate section for more information.

The vehicle location/direction is determined using the following:

- Global positioning system (GPS)
- Vehicle speed
- Gyroscope to detect directional changes
- Navigation software integral to the Navigation Control Module

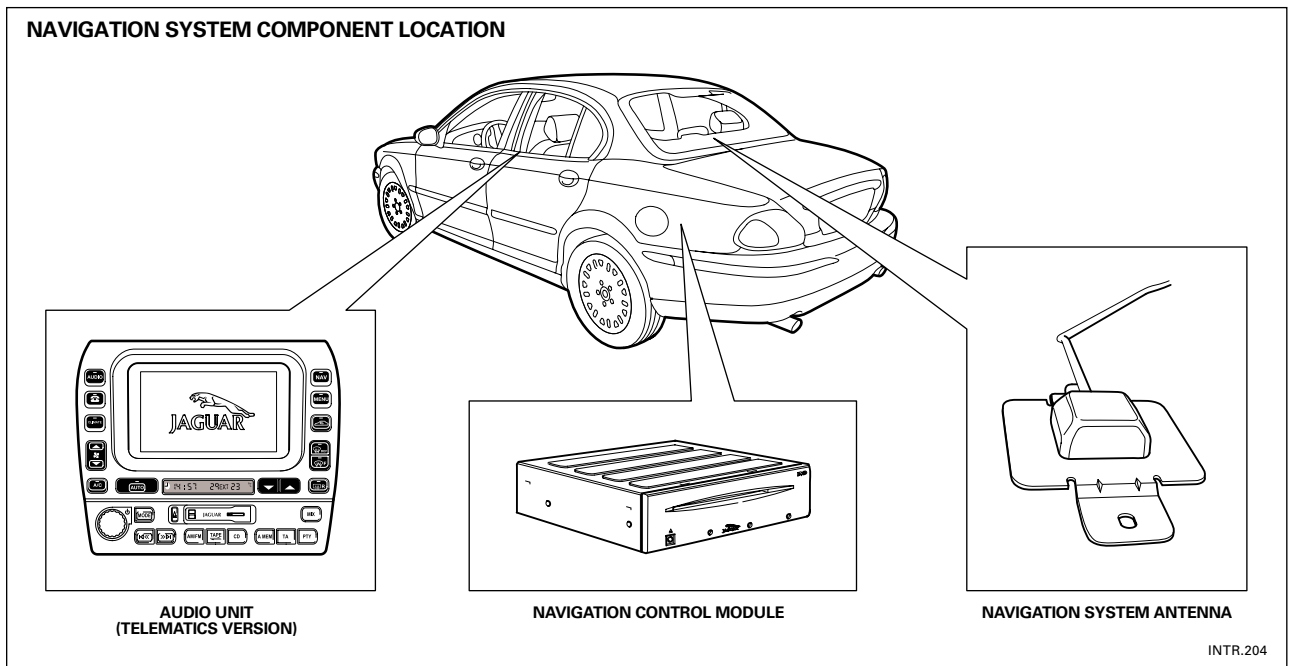

NOTES

Navigation Control Module

The navigation control module (NCM) comprises:

- Navigation software which controls:
 - generation of map display
 - routing functions
- Graphics display driver
- D2B output of audio data for voice guidance and television
- SCP link for communications between other modules
- Subsystem control software to generate control screens for other modules and support communications
- GPS decoder which amplifies and decodes the GPS signal received from the antenna
- Gyroscope to monitor vehicle direction
- DVD drive which reads the map database stored on disk
- Diagnostic software

Navigation System Display Module

The display module is a multifunction touch screen console which comprises on-screen simulated buttons (soft buttons) and perimeter buttons (hard buttons). Unlike other Jaguar models, the display module is not dedicated to navigation, it is also:

- The principal interface for several subsystems – climate control, phone, voice activation
- An integral component of the audio unit

Navigation System Antenna

The navigation system antenna is a satellite GPS type. It is common to all models and is mounted on the parcel shelf to optimize reception. The coaxial cable links the antenna module to the NCM and:

- Provides 5V dc power from the NCM to active receiver circuits of the antenna via the inner coaxial conductor
- Transfers incoming signals from the antenna to the NCM

NOTE: Signal reception may be affected by the presence of metal objects or foil on or near the parcel shelf or rear screen.

NOTES

BODY SYSTEMS

Voice Activated Control System

Where installed, the voice activated control system for X-TYPE is an expansion of the S-TYPE system and offers the user the option to voice-activate certain features for the following:

- Entertainment system
- Cellular phone system
- Climate control system
- Navigation system

NOTE: The voice activated control system can only be installed during manufacture. It is not available as an accessory.

The system components comprise:

- Voice activation control module (VACM) located in left side of the luggage compartment
- Microphone, shared with the phone and integrated into the roof console
- Push-to-talk button, mounted on the steering wheel, shared with the phone and wired through the audio unit

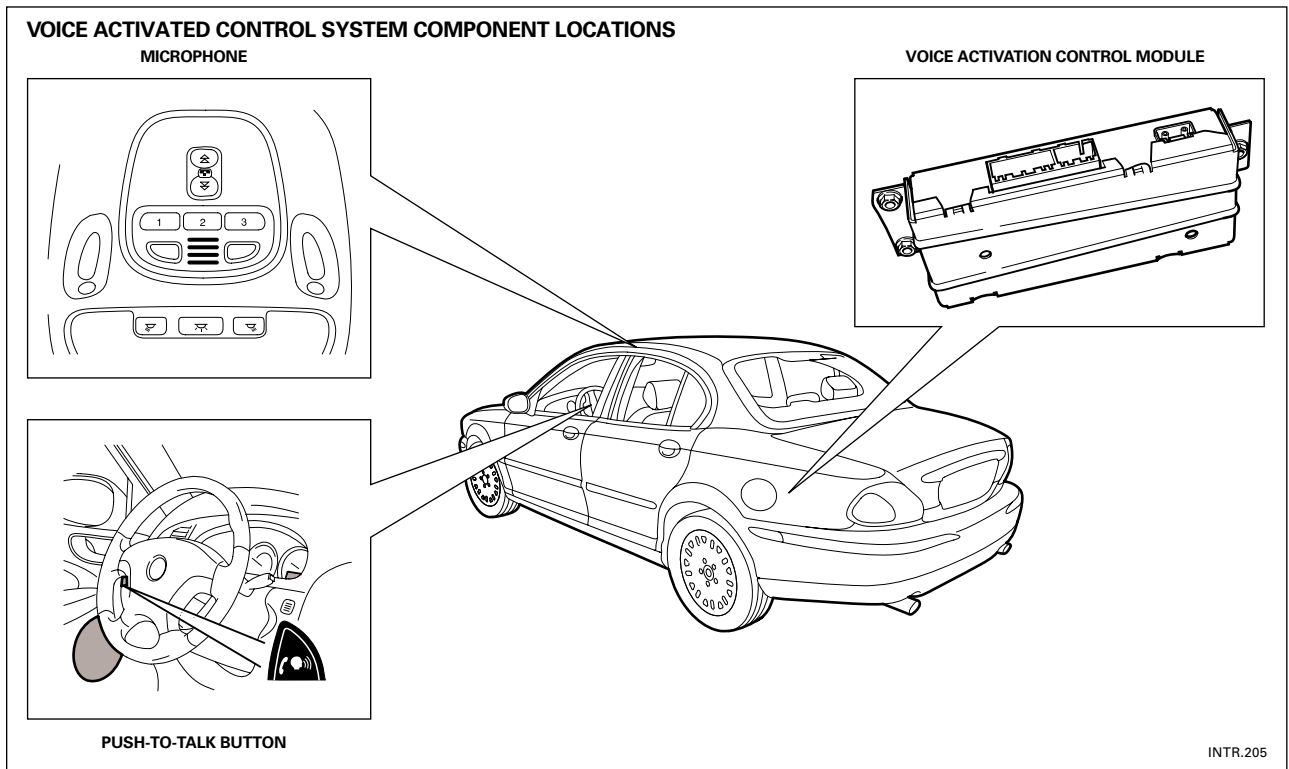

NOTE: Where applicable, it is possible to initiate a training mode which enables the voice activated control system to fine-tune the voice recognition capability.

The VACM is not serviceable but will need to be reconfigured using WDS if changes are made to the systems it controls; for example after the installation of a CD changer.

NOTE: The VACM is part of the optical network.

INTRODUCTION TO JAGUAR



GENERAL INFORMATION

1 INTRODUCTION TO XJ/XK

2 INTRODUCTION TO S-TYPE

3 INTRODUCTION TO X-TYPE

3.1 Overview

3.2 Engine

3.3 Engine Management

3.4 Transmissions and Driveline

3.5 Suspension, Steering and Brakes

3.6 Climate Control

3.7 Electrical Distribution System

3.8 Body Systems

3.9 Occupant Protection

3.10 Task Sheets



OCCUPANT PROTECTION

Advanced Restraints System

New technologies have permitted the development of an 'Advanced Restraint System' that provides an improved overall level of crash protection for vehicle occupants. The system analyzes the occupancy scenario and crash severity before activating the appropriate safety devices to help better protect a range of occupants in a variety of crash situations. Benefits of the new system include:

- Optimization of the deployment restraint devices and reduction in potential for airbag induced injuries
- The significant reduction in passenger airbag deployments (particularly when passenger seats are unoccupied) and a general reduction in all airbag deployments

In order to support the advanced restraint system requirements, a restraint control architecture has been introduced comprising the following systems or components:

- All-electric crash sensing with frontal crash severity sensing and advanced restraints management
- Driver airbag with twin stage inflator
- Passenger airbag with twin stage inflator
- Child seat lower ISOfix anchors for rear seats
- Safety belt system including: front belt use detection, load limiting retractors and buckle pre-tensioner
- Front seats including: driver seat track position sensor and passenger seat weight-sensing system
- Lower steering column
- Front seat-mounted side airbags
- Side curtain airbag

NOTES

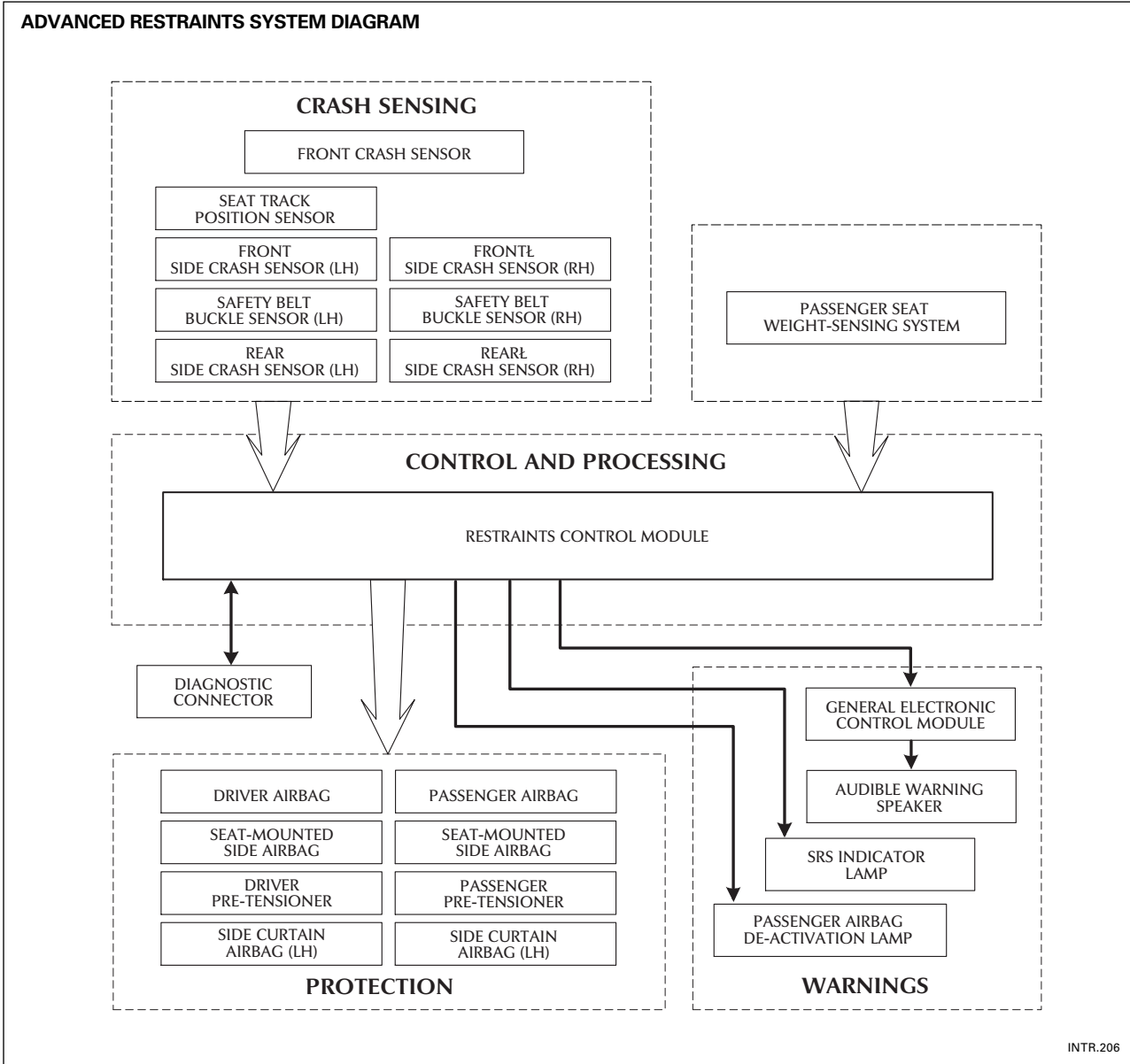

OCCUPANT PROTECTION

Airbag Modules

Driver Airbag Module

The driver airbag module is controlled by the restraints control module (RCM), which chooses between first or second stage deployment, depending on driver seat buckle usage, seat track position and crash severity.

NOTE: Variation in passenger airbag deployment is determined by the timing of the first and second stage ignition signals. This facilitates adaptation of stiffness and timing of the airbag to optimize occupant protection.

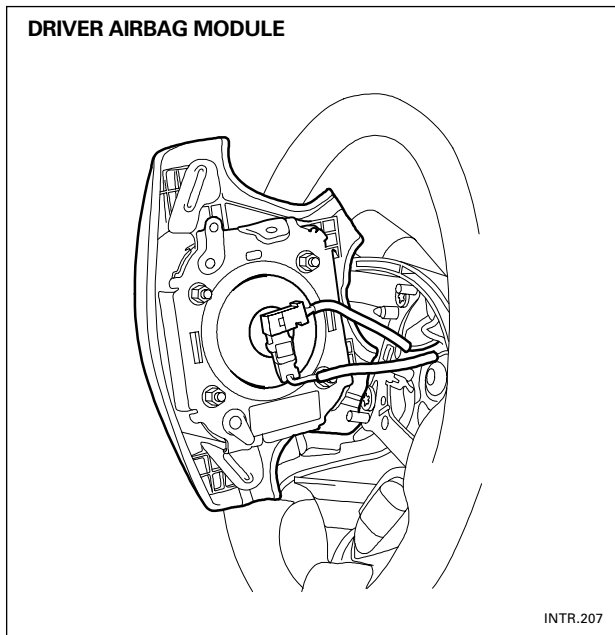

The module comprises:

- A twin stage inflator as opposed to a single stage inflator
- Separate chambers for the two inflation stages, each independently activated by the RCM
- Two air bag connectors, that have foolproof mechanical keying and are color coded to the respective plug on the inflator
- A non-azide propellant that reduces particulates and effluents

The airbag deploys radially, to reduce the risk of airbag induced injury to a driver that is positioned close to the steering wheel.

NOTE: Disposal of twin stage airbags is different than with single stage airbags; refer to JTIS.

NOTES

Passenger Airbag Module

The module comprises:

- A twin stage inflator as opposed to the single stage inflator
- Two airbag connectors to accommodate the twin stage inflation

The heated gas inflator:

- Comprises a high-pressure mix of clean air and hydrogen gas, triggered by two separate igniters
- Produces a controlled generation of clean gas to rapidly fill the airbag
- Is classified as a stored flammable gas (not as an explosive) and as such, has less restrictive storage and transportation requirements
- Produces a very clean burn and almost no particulates
- Is almost free of any toxins, making disposal or recycling much easier

NOTE: Disposal of twin stage airbags is different than with single stage airbags; refer to JTIS.

The passenger air bag module is controlled by the restraints control module (RCM), which chooses between first or second stage deployment, depending on occupant status and crash severity.

NOTE: Variation in passenger airbag deployment is determined by the timing of the first and second stage ignition signals. This facilitates adaptation of the stiffness and timing of the airbag to optimize occupant protection.

NOTE: This passenger airbag module can be removed through the glovebox aperture; refer to JTIS.

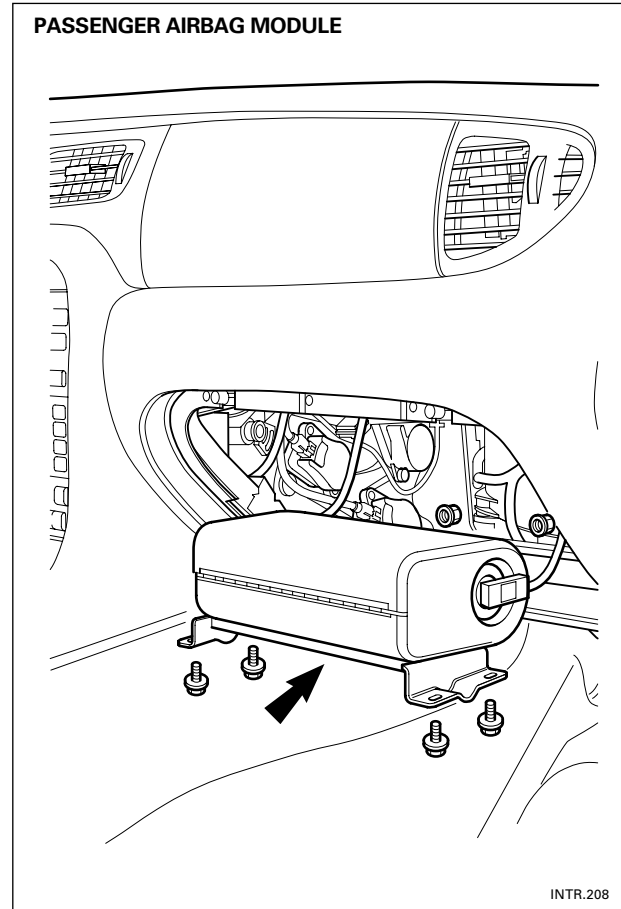

NOTES

OCCUPANT PROTECTION

Airbag Modules (continued)

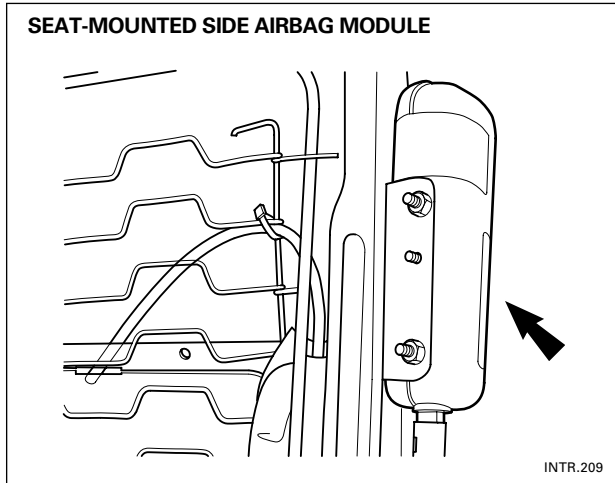

Seat-Mounted Side Airbag Module

The seat-mounted side airbag is designed to provide protection for the thorax (the part of the torso between the neck and the abdomen). The module:

- Is mounted in the outboard bolster of each front seat
- Is standard fit and specification in all markets
- Does not require maintenance
- Has no serviceable parts
- Uses compressed argon to inflate the bag

NOTE: As with all occupant safety components, the SRS indicator lamp will illuminate if a DTC has been stored. Diagnosis must be undertaken using WDS.

In an airbag deployment situation, the airbag deploys through the stitched seam in the side bolster. A chute has been designed into the inside of the trim cover to ensure the airbag always emerges at the same point.

WARNING: IN A SERVICE SITUATION, THE MODULE MUST BE CORRECTLY LOCATED IN THE CHUTE. FAILURE TO FOLLOW THE SERVICE PROCEDURE COULD RESULT IN INCORRECT AIR BAG DEPLOYMENT; REFER TO JTIS.

NOTE: In the event of a side impact that is sufficient to deploy the bag, it will be necessary to replace the complete seat.

NOTES

Side Curtain Airbag

The side curtain airbag has been designed uniquely for X-TYPE and comprises:

- Attachment brackets (p-clips)
- Fill tube
- Airbag
- Housing
- Inflator
- Front/rear tethers

The side curtain airbag:

- Is standard fit and specification in all markets
- Is located under the headliner and stabilized at the 'A' post and 'C' post by tethers
- Does not require routine maintenance
- Has no serviceable parts
- Uses compressed argon to inflate the airbag
- Deploys to coincide with seat-mounted side airbag deployment

NOTE: If the passenger airbag is deactivated, the corresponding seat-mounted side airbag is also deactivated, however the side curtain airbag will still deploy to afford protection to any corresponding rear occupant.

- After deployment, the side curtain airbag extends down to approximately shoulder height providing head protection for both the front and rear occupants

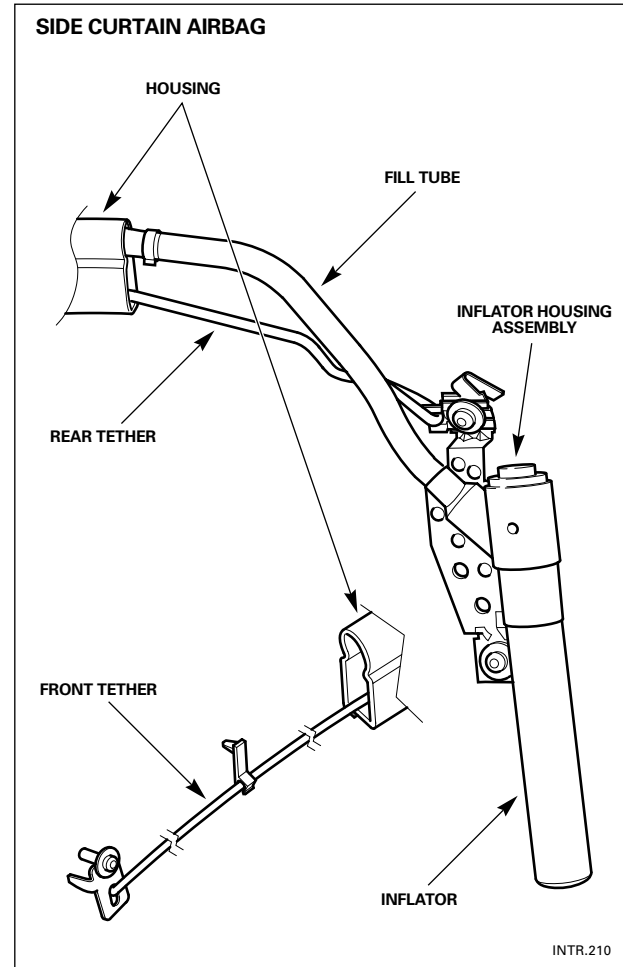

The inflator:

- Generates the gas needed to fill the airbag
- Consists of a high strength steel casing filled with a solid propellant charge, an electrically activated igniter and a cold gas bottle containing pressurized gas

When appropriate, the restraints control module (RCM) sends a signal to the igniter causing the following sequence of events:

- The propellant is ignited
- The burning propellant opens the membrane of the cold gas bottle and heats the pressurized gas
- The expanding gas is directed into the fill tube by the inflator housing assembly
- The gas emerges through holes in the fill tube and enters the front and rear side curtain airbag chambers

Steering Column

The steering column is an integral part of the occupant safety system.

