

Glove Compartment 76.52.03

Removal

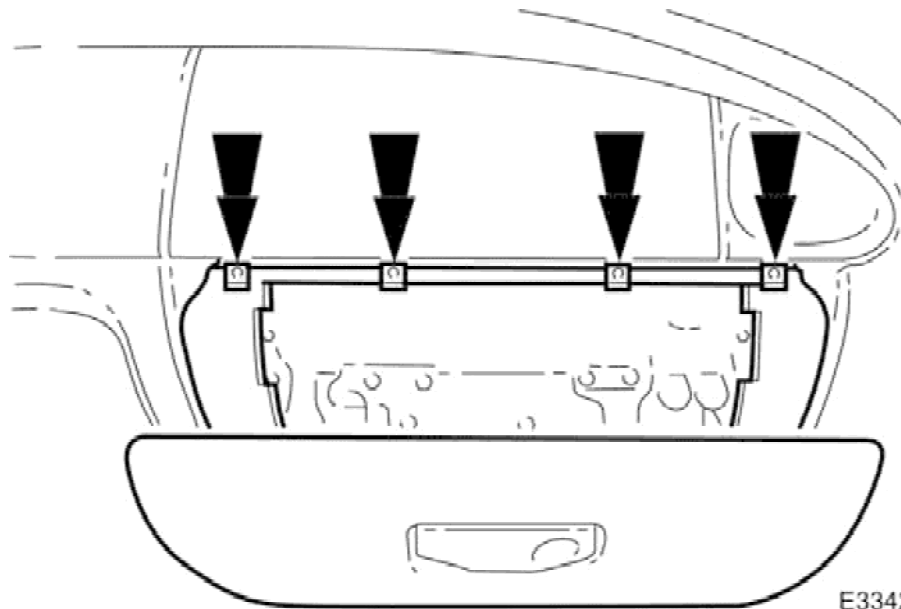

1. Open glove box lid and slacken and remove four screws securing liner to the fascia.

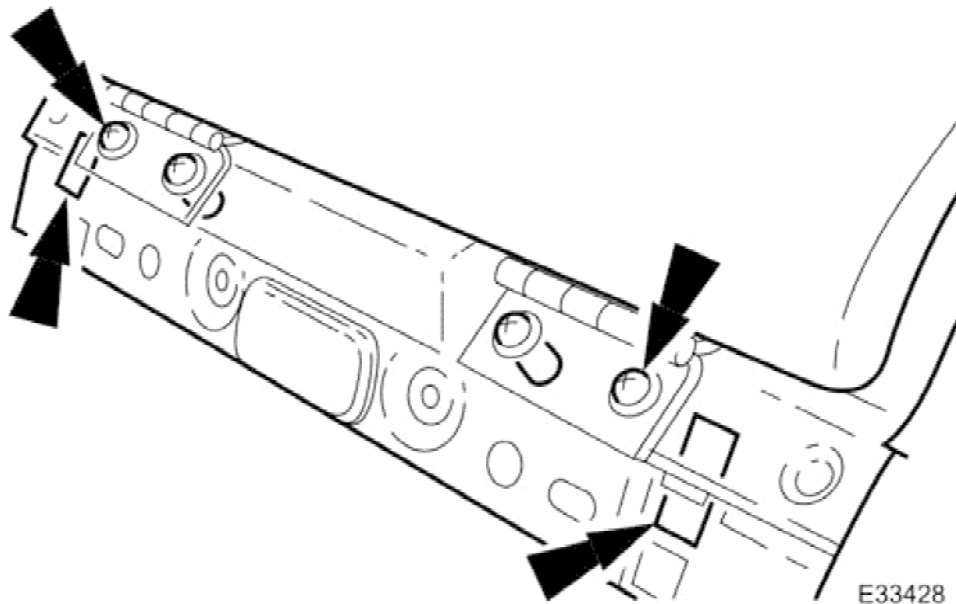

2. NOTE:

Do not disturb the two inner screws as these are for glovebox alignment only.

Slacken and remove two outer screws securing glovebox to cross-member.

- Withdraw liner tangs and dowels from cross-member and separate liner.

3. Position glove box for access, disconnect footwell and glovebox lamp multiplugs and withdraw the glove

2003 XK RANGE - Instrument Panel and Console - 501-12

box assembly.

Installation

1. Position glovebox at fascia cross-member and connect footwell and glovebox lamp multiplugs.
2. Locating plastic dowels in apertures, seat glovebox on cross-member.
3. Install but do not fully tighten lower securing screws.
4. Install but do not fully tighten glovebox upper securing screws.
5. Carefully close glovebox lid and align assembly with fascia.
6. Fully tighten all glovebox securing screws.