

**Crankshaft Pulley Vehicles With: Supercharger 12.21.09**

**Special Service tools**

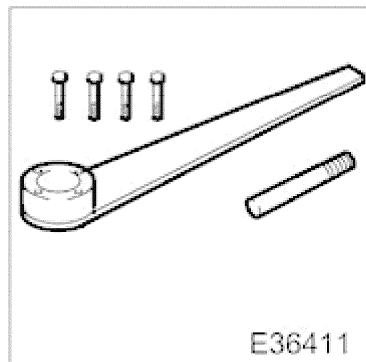

Crankshaft locking, main tool  
303-191

---

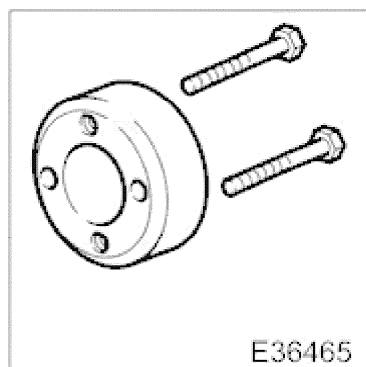

Adaptor  
303-191-02

---



Adaptor  
303-191-03

---

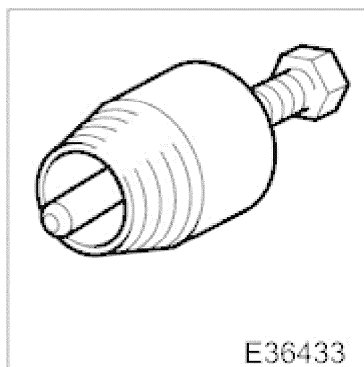

Crankshaft front seal remover  
303-541

---

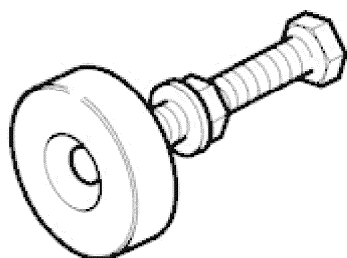

E36434  
Crankshaft front seal replacer  
303-542

---

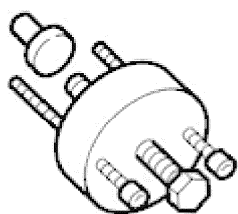

E36440  
Crankshaft pulley/damper remover  
303-588

---

## Removal

1. Open the engine compartment and fit paintwork protection sheets.
2. Set the engine compartment cover to the service access position.
3. Remove the supercharger drive belt. Refer to Operation <<18.50.08>>.
4. Remove the drive belt from the front accessory drive. Refer to Operation <<12.10.40>>.

5. Remove the twin fan and motor assembly for access. Refer to Operation 26.25.12

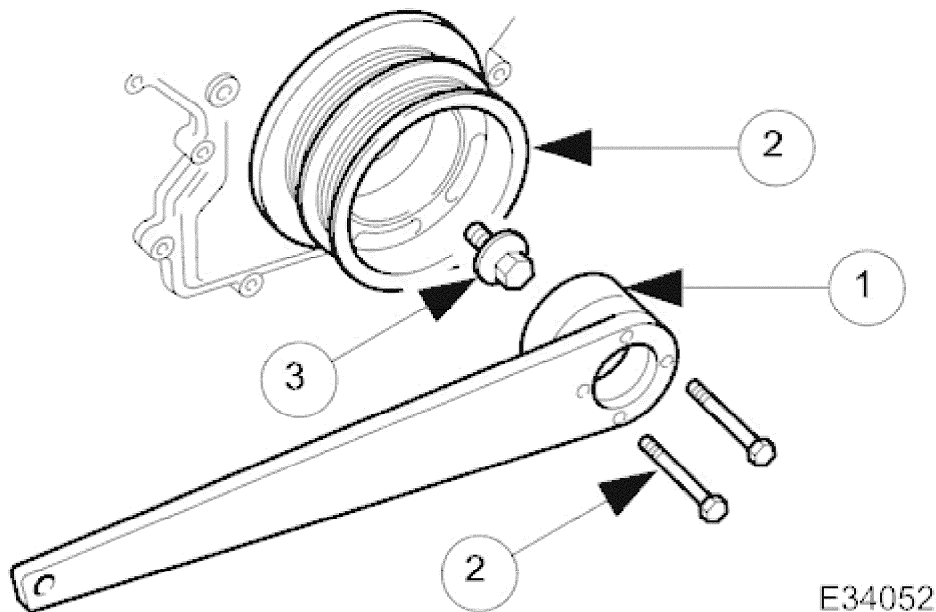

6.  **CAUTION:**  
**Under no circumstances should the crankshaft setting peg 303-531 be used in the following operations, to lock the crankshaft.**

**NOTE:**

Should extra locking of the crankshaft be required, use a lever against one torque converter boss. Remove the plastic mesh cover from the torque converter housing for access.

Install the crankshaft locking tool to the damper.

1. Install adaptor 303-191-03 to the main locking tool 303-191.
2. Reposition the crankshaft/damper to align the mounting holes and install the locking tool to the damper using the bolts provided with the tool.
3. Loosen, but do not remove the damper securing bolt from the crankshaft.

7. Remove the locking tool from the damper.

- Remove the damper securing bolt.

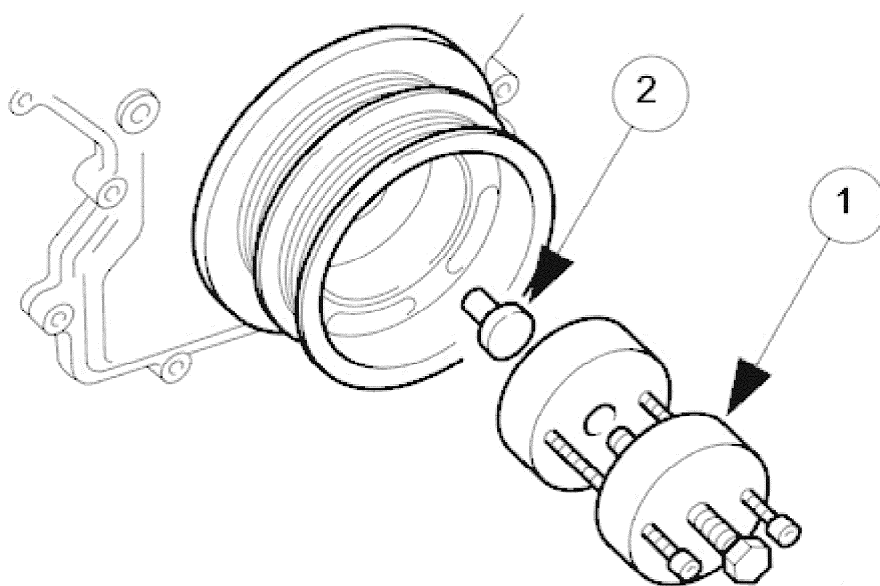

E34053

**8. NOTE:**

The damper only needs to be withdrawn along the crankshaft nose by approximately 2mm before removing the puller. The damper will then either be loose or only require a sharp tap with a mallet to release it from the split locking ring.

Remove the damper from the crankshaft.

1. Install adaptor 303-191-02 to the damper extractor tool 303-588 (Use the socket head screws provided with the puller).
  2. Locate the thrust button into the end of the crankshaft; the O-ring holds it in place.
- Assemble the puller to the damper.
  - Extract the damper from the crankshaft.

9. Remove the puller components from the damper.

- Remove the thrust button from the end of the crankshaft.

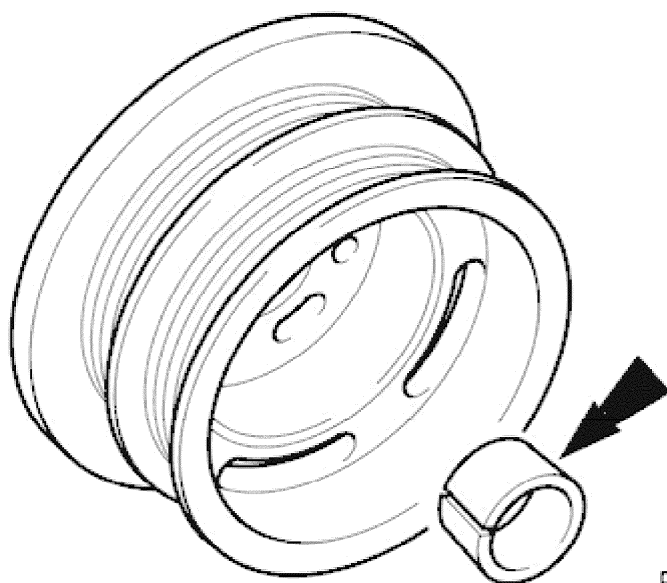

E34051

10. Remove the split locking ring from the damper.

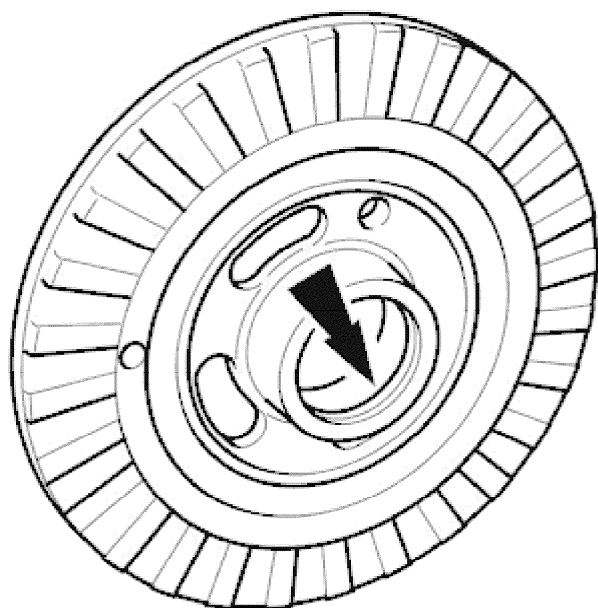

E32839

11. Remove the internal O-ring seal.

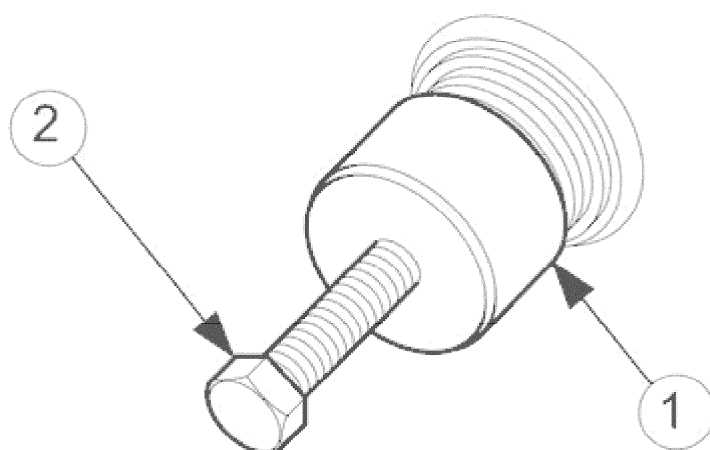

E35326

12. Remove the crankshaft front seal.

1. Install and tighten the removal tool 303-541 to the crankshaft front seal.
  2. Tighten the centre bolt of the tool to extract the seal.
- Remove the tool and seal assembly.
  - Separate the seal from the tool.

13. Very carefully clean the threads of the crankshaft, using a plug tap M16x2, to remove all old cured sealant.

- Keep the tap horizontal. Do not enlarge the crankshaft thread - remove sealant only.

14. Clean all relevant parts and faces.

## Installation

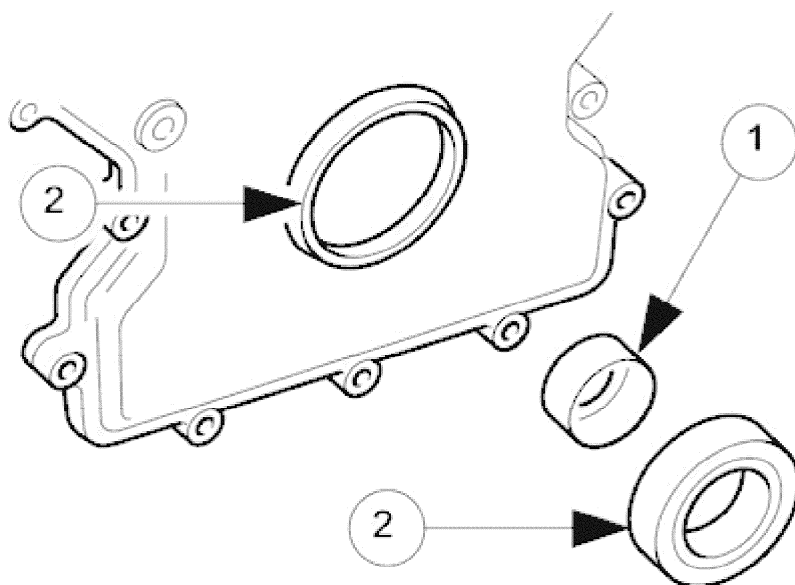

E32811

1. Locate the new oil seal into the timing cover.
  1. Remove the transit ring from the oil seal.
  2. Position the seal to the timing cover.

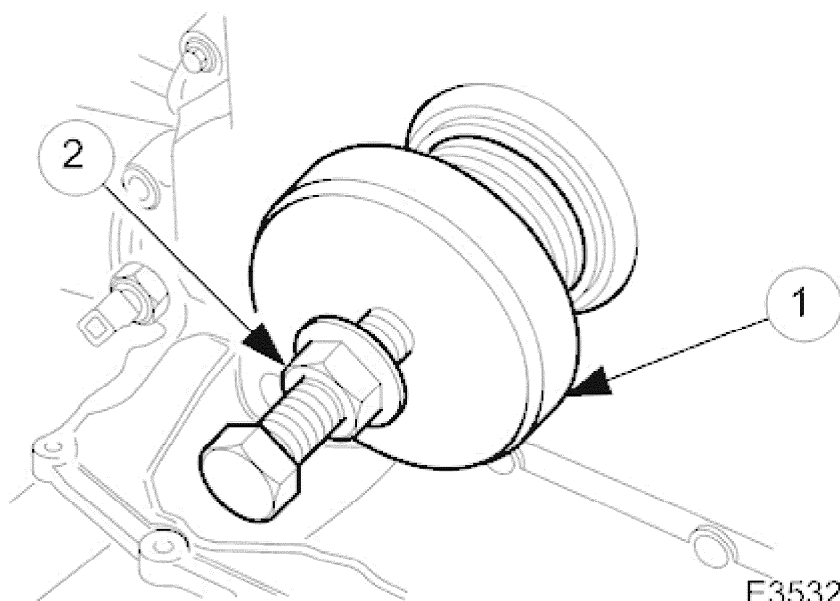

E35327

2. Install the new oil seal to the timing cover.
  1. Install oil seal replacer tool 303-542 to the oil seal.
  2. Use the nut and bolt provided with the tool, to fully seat the seal to the timing cover. Only tighten the nut sufficiently to locate the seal and no more, or the timing cover could become distorted.
    - Allow the tool to stay in position against the seal for at least five seconds.
    - Remove the special tool from the seal.
3. If the damper is not to be installed immediately, the transit ring should be installed temporarily to the seal.

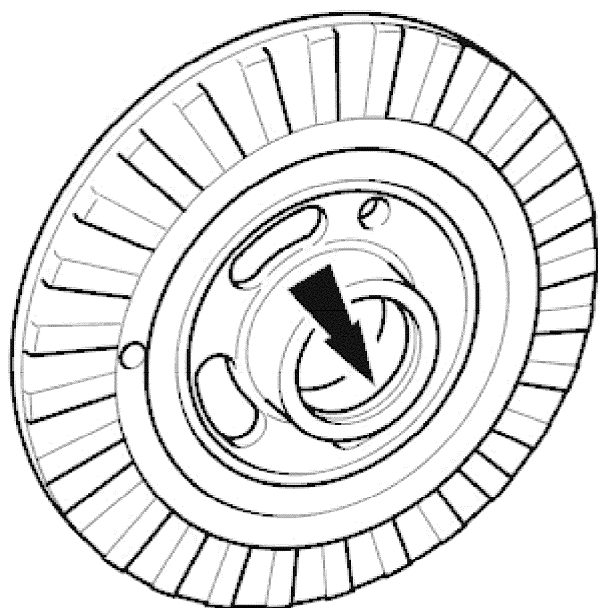

E32839

4. Install a new O-ring seal to the damper.

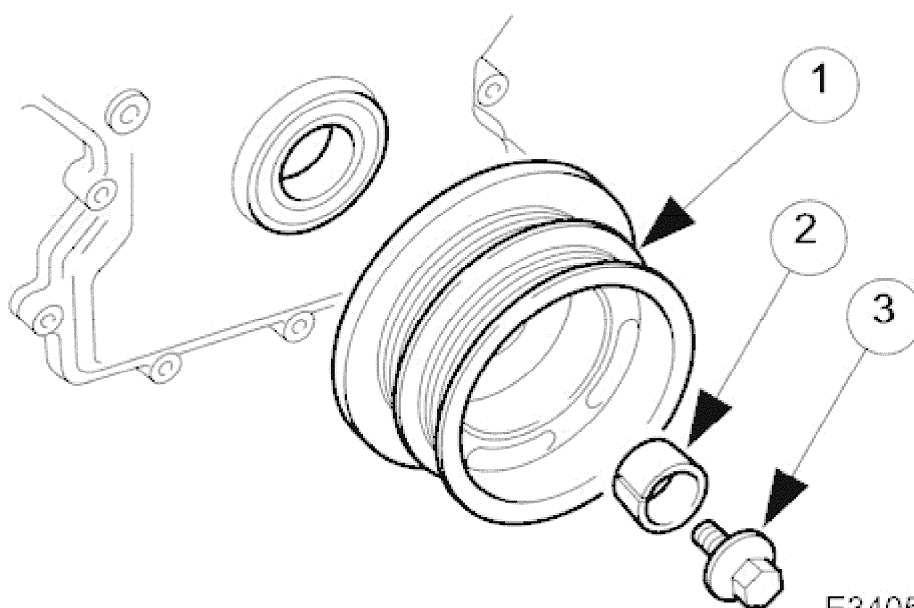

E34054

5. Install the crankshaft damper.

- Apply petroleum jelly to the damper bore and O-ring seal.

1. Install the damper onto the crankshaft.

2. Install the split locking ring onto the crankshaft, inside the centre bore of the damper.

3. Install, but do not tighten, a new damper securing bolt.

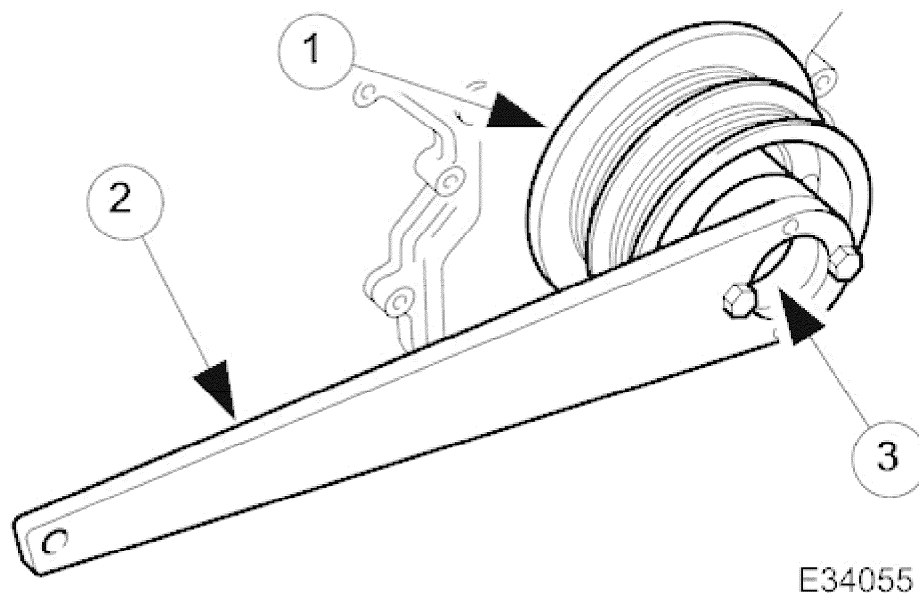

E34055

6.  **CAUTION:**  
**Under no circumstances should the crankshaft setting peg 303-531 be used in the following operations, to lock the crankshaft.**

Tighten the damper securing bolt.

1. Reposition the damper to allow access to the bolt holes for installing the locking tool.
  2. Install the locking tool (303-191 and 303-191-03) to the damper using the bolts provided.
  3. Fully tighten the damper securing bolt to 364-386 Nm.
7. Remove the locking tool from the damper.
8. Install the drive belt to the front accessory drive. Refer to Operation <<12.10.40>>..
9. Install the supercharger drive belt. Refer to Operation <<18.50.08>>.
10. Install the twin fan and motor assembly. Refer to Section 303-03.
11. Install the plastic mesh cover to the torque converter housing; if removed for access to lock the crankshaft.
12. Reset the engine compartment cover to the normal position and connect the gas struts.
13. Remove the paintwork protection sheets and close the engine compartment.