



XK

DATE 07/01

303-46

SERVICE

TECHNICAL BULLETIN

Check Engine MIL Illuminated –
DTC P0442, P0455, P0446 –
Replace Canister Control Valve

MODEL 2000-01 MY
XK Range
VIN A00083-A13691

Issue:

Some 2000-2001 MY XK vehicles within the above VIN range may experience customer complaints of the check engine Malfunction Indicator Lamp (MIL) illuminating, with DTCs P0442, P0455, P0446 stored. This can be caused by internal corrosion in the vapor pipe that vents the carbon canister to the atmosphere. This causes rust particles to enter the Canister Close Valve (CCV), causing the valve to stick open.

Action:

Using the WDS, check the Engine Control Module (ECM) for Diagnostic Trouble Codes (DTCs). The following DTCs may be stored:

DTC Description

P0442 EVAP System leak detected (small)

P0455 EVAP System leak detected (large)

P0446 CCV Malfunction

Note: It is possible that other DTCs may be stored.

If any of the above DTCs are stored, trace the source of the leak using the 'K' Line leak detection equipment.

If the leak test determines that the canister close valve is the cause of the leak, replace the valve and vapor pipe.

Note: The vapor pipe must be replaced under Service Action S837. The CCV must be replaced under the new car warranty.

To replace the CCV, follow the Workshop Procedure below.

WORKSHOP PROCEDURE

1. Raise vehicle on lift.

DISCONNECTING VAPOR PIPE HOSE AT FILTER

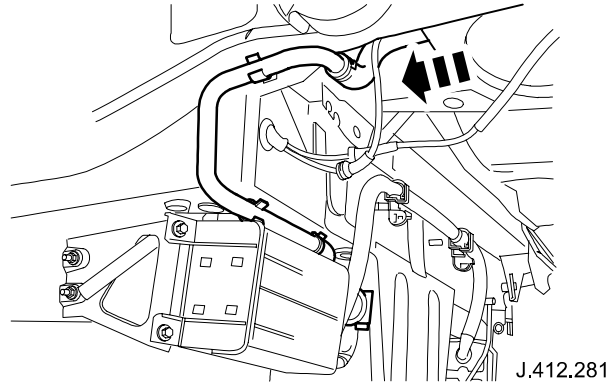

ILLUSTRATION 1

2. Disconnect vapor pipe hose from filter (Illustration 1).

PLASTIC BODY CLIPS

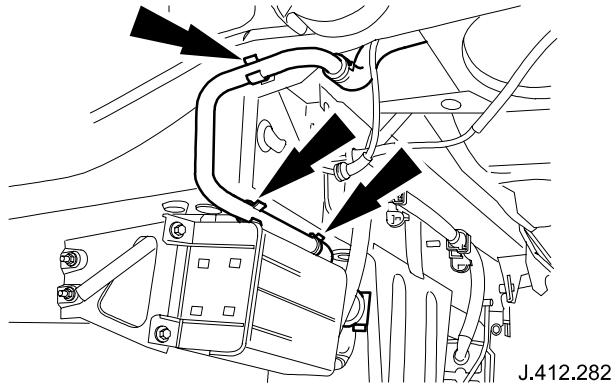

ILLUSTRATION 2

3. Detach vapor pipe from plastic body clips (Illustration 2).

RUBBER COVER FOR CONNECTOR

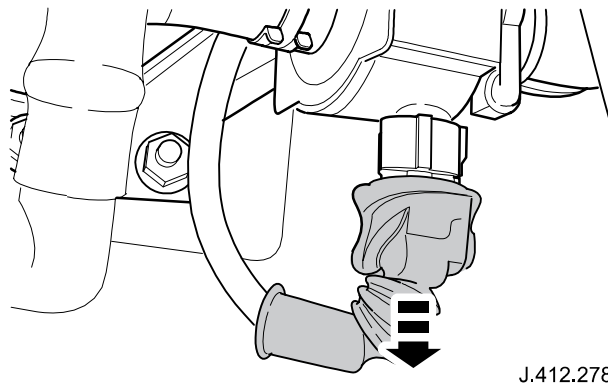
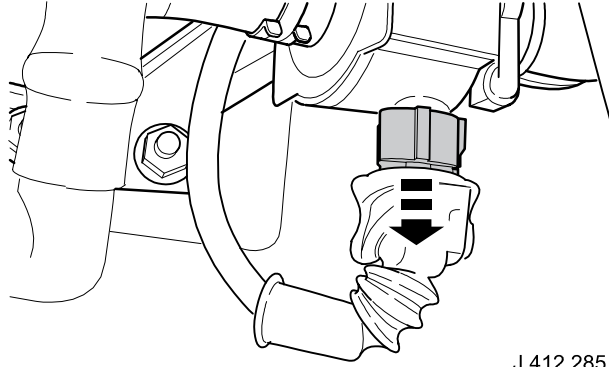

ILLUSTRATION 3

4. Reposition canister close valve connector rubber cover for access (Illustration 3).

CANISTER CLOSE VALVE CONNECTOR



J.412.285

ILLUSTRATION 4

5. Disconnect canister close valve connector (Illustration 4).

CANISTER CLOSE VALVE HOSE CLIP

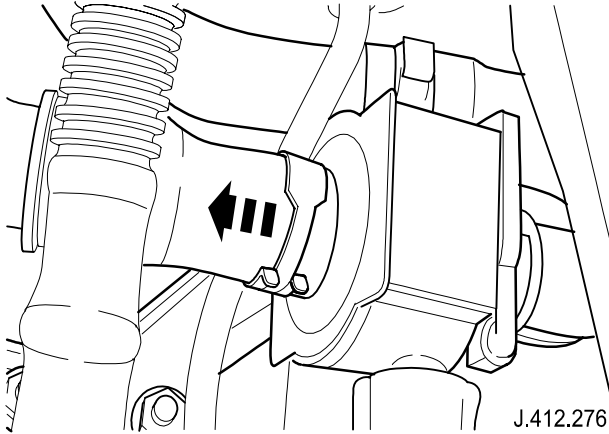

J.412.276

ILLUSTRATION 5

6. Release and reposition the clip that secures the hose to the canister close valve (Illustration 5).

CCV SECURING NUT

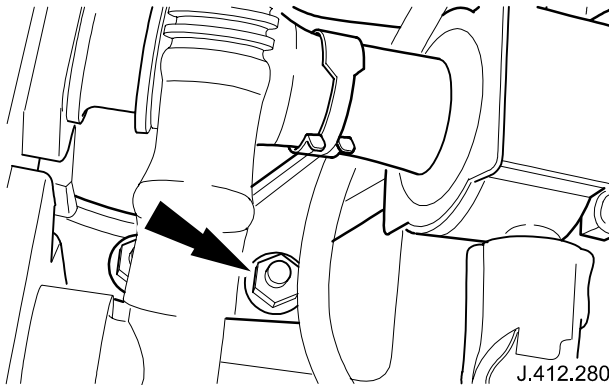

J.412.280

ILLUSTRATION 6

7. Remove the nut that secures the canister close valve to the body (Illustration 6).

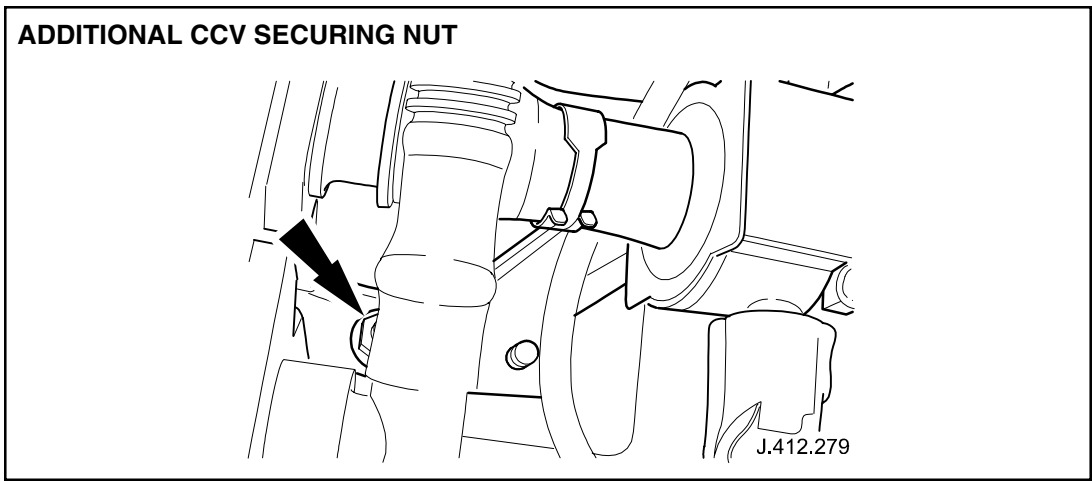

ILLUSTRATION 7

- 8. Remove the nut that secures the carbon canister to the body (adjacent to canister inlet/outlet pipes, Illustration 7).
- 9. Reposition the canister close valve and the carbon canister from the body studs for access.
- 10. Disconnect the canister close valve from the carbon canister hose.

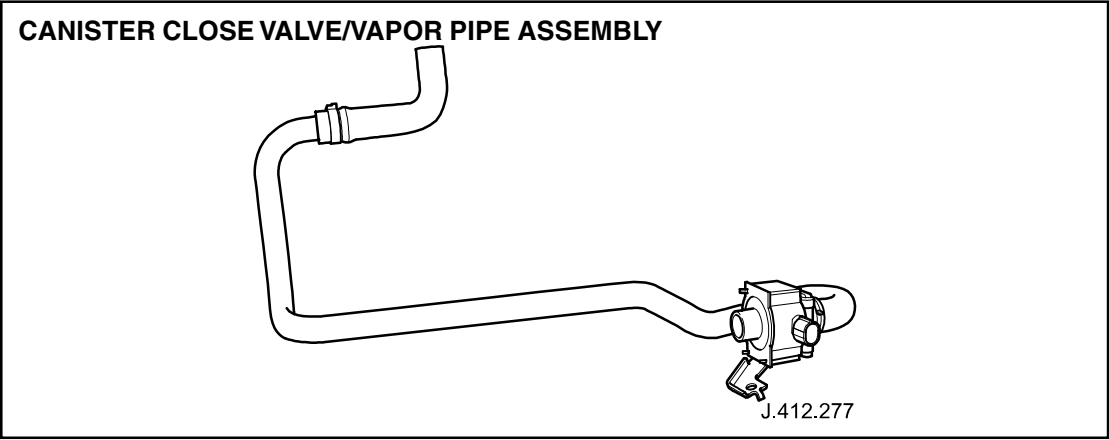

ILLUSTRATION 8

- 11. Remove the canister close valve/vapor pipe assembly from vehicle (Illustration 8).

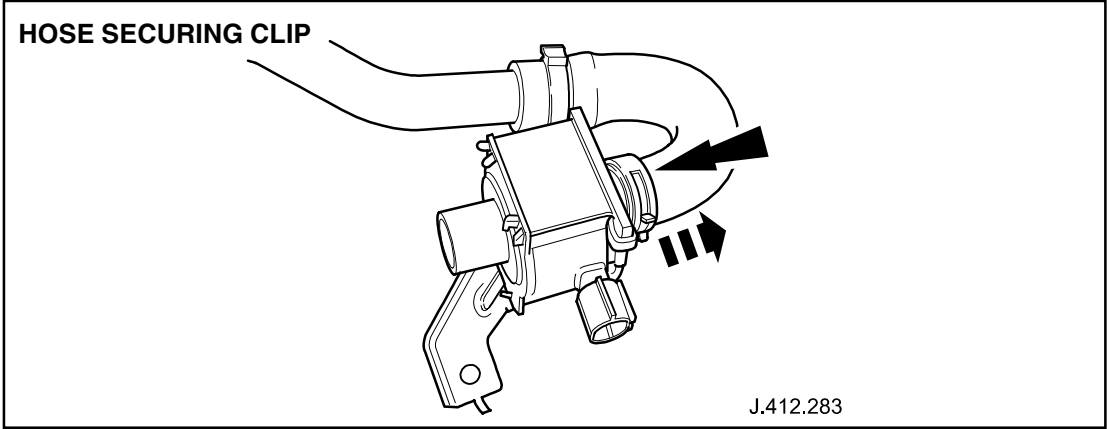

ILLUSTRATION 9

- 12. Release and reposition the clip that secures the vapor pipe hose to the canister close valve (Illustration 9).

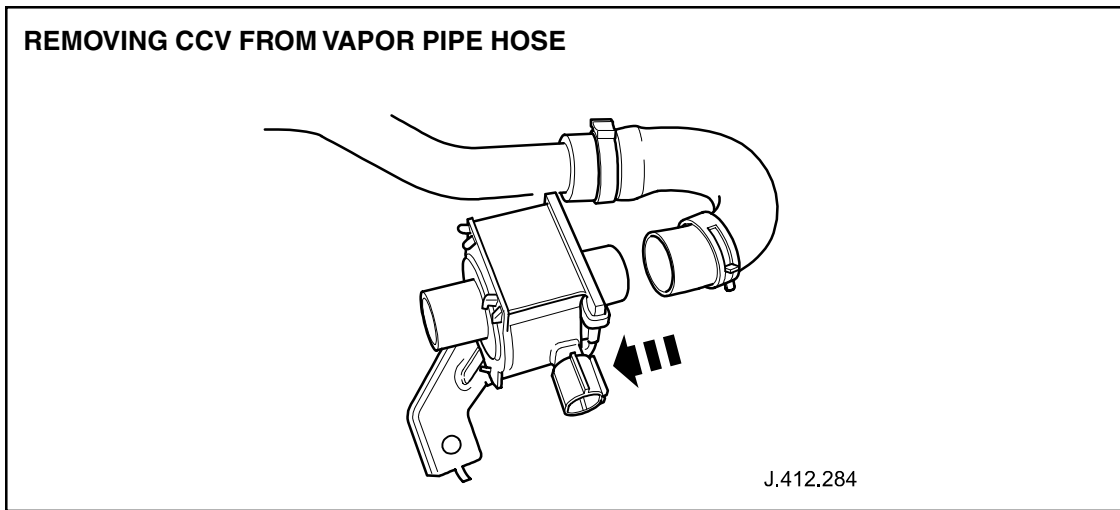

ILLUSTRATION 10

13. Remove the canister close valve from the vapor pipe hose and place aside (Illustration 10).

Note: The vapor pipe must be replaced under Service Action S837. Ensure the vapor pipe is the latest version.

14. Insert the new canister close valve into the vapor pipe hose.
15. Reposition the clip that secures the vapor pipe hose to the canister close valve.
16. Fit canister close valve/vapor pipe assembly on the vehicle.
17. Connect the canister close valve to the carbon canister hose.
18. Reposition the carbon canister and the canister close valve on the body studs. Ensure that the canister close valve bracket alignment tang engages the body hole.
19. Install and tighten the nut that secures the carbon canister to the body.
20. Install and tighten the nut that secures canister close valve to the body.
21. Reposition the clip that secures the canister close valve to the carbon canister hose.
22. Connect the canister close valve connector.
23. Reposition the rubber cover over the connector of the canister close valve.
24. Secure the vapor pipe in the plastic body clips.
25. Connect the vapor pipe hose to the filter.
26. Lower the vehicle.
27. Recheck the EVAP system for leaks.

Parts Information:

<u>DESCRIPTION</u>	<u>PART NUMBER</u>
Canister close valve	LJC 1525AB

Warranty Information:

<u>FAULT CODE</u>	<u>R.O. NUMBER</u>	<u>DESCRIPTION</u>	<u>TIME ALLOWANCE</u>
BK BL 55	17.15.45	Canister close valve - replace	0.2 hrs.