

**The 2003-2005 Jaguar XK8 Convertible.** Some content in this primer has been blatantly ripped-off from various sources, some with attribution, some without, and I apologize for this in advance. Hopefully you will find this article useful. What I'm striving for is a concise view of the car for the new owner that can be kept with your driver's manual, not a service manual. A good service manual CD for this range is available from JagDocs.com. If you own one of these fine cars, you should get accurate electrical diagrams for your model year, acquaint yourself with all SBs and how/if they apply to your particular vehicle and participate in Jaguar Forum discussions. Mine is a US model (Left Hand Drive). Quite a few changes were made from the early launch to mature design years and sometimes documentation, even that coming directly from Jaguar, is flat out wrong concerning which parts are installed on which model year vehicles. If you are aware of content errors and/or omissions that should be addressed in future revisions, please contact me directly at [vanremog@aol.com](mailto:vanremog@aol.com).

**By Gary R VanRemortel    Revision B dated 09/03/13**



**Engine Type:** DOHC aluminum alloy 32-valve 4.2L 90° V8  
**Avg Fuel Economy:** 21 mpg  
**Bore/Stroke:** 86 mm / 90.3 mm  
**Compression Pressure:** ~180 psig  
**Warm Idle:** 650 rpm  
**Max Power/Torque:** 294 hp SAE @ 6000 rpm / 303 lb-ft SAE @ 4100 rpm  
**Wheelbase/Width/Track/Length/Height:** 101.9 in / 70.8 in / 59 in / 188 in / 51 in  
**Minimum Turning Radius:** 18.1 ft  
**Max Speed (Ignition limited):** 155 mph  
**Acceleration (0 - 60 mph):** 6.3 sec  
**Curb/Gross Weight:** 3980 lb / 4808 lb  
**Coefficient of Drag:** 0.36  
**Spark Plugs/Gap/Torque:** NGK 7866 IFR5N-10 Iridium / .046" ± .006" / 20 lb-ft  
**Coolant 50/50:** ~10 qt Dexcool OAT (Red/Orange)  
**Fuel:** 19.9 gal / 91 octane unleaded gasoline  
**Fuel Pressure:** 42 psig above MAP  
**Oil Circulation Volume/Pressure:** ~10 gpm / @ cruise 55 to 65 psig (@ warm idle >10 psig)  
**Differential Fluid:** 2 qt 75W90 Redline Synthetic  
**Power Steering and Soft Top Hydraulic Fluid:** Pentosin CHF11S  
**Brakes Front/Rear:** 325 mm Vented slotted and drilled disc / 305 mm Vented disc  
**Brake Fluid:** Super Blue Racing DOT 4  
**Battery:** AC Delco 49PS 90 Ah  
**Alternator:** NipponDenso 130 A  
**Wheels Front/Rear:** Keystone ALY59794U85 (19X8) / ALY59795U85 (19X9)  
**Tires Front/Rear:** Michelin Pilot Super Sport P245/40ZR19 (32 psig) / P255/40ZR19 (34psig)  
**Lug Nut Bolt Circle/Torque:** 4.75 in / 70 lb-ft

## Overview

Enthusiasts describe the XK8 as having poise, grace and refined power. The long bonnet, short boot proportions and large oval grille opening evoke familiar classic features of the XKE. In contrast to the newer aluminum bodied XK (a design influenced by Kate Winslet), the XK8 is more stretched out, low, lean and uncluttered by distracting bling. The car has a look that is both muscular and voluptuous at the same time, due to its length, large wheels and convex panels. Tear-drop eye shaped lighting fixtures enhance its distinctive cat-like animal aura. The original door rub strips from the '90s are gone, leaving a clean smooth look, so be sure to park well away from potential door bangers.

High-strength steel members throughout the car assure a rigid body structure, while crumple zones at the front and rear corners absorb forces in a crash. There is no room under the hood for a damper mount reinforcement cross-brace. Convertibles benefit from additional cross-bracing under the engine bay, stiffening members in the door sills and a reinforced windshield frame, helping compensate for the lack of a roof structure and significantly reducing scuttle shake. From its basic structure through to its sophisticated electronic control systems and safety provisions, Jaguar engineers designed the XK8 to deliver intelligent innovation and one can easily see that the designers were deeply emotionally invested in the X-100 project that ultimately produced the XK8/XKR, clearly believing that they were creating drivable art.

The XK8 body is entirely new but is based on a modified XJS floor pan. The body-in-white is both stiffer and lighter than that of the XJS. Torsional stiffness is improved by 25% and the body structure consists of 30% fewer panels. Special high-strength steels form the panels subject to the highest loads (approximately 15% of the body), including the front longitudinals, seat-belt anchors, mounting points for the suspension, bumper mounts and the side-impact beams within each door.

Convertible owners will certainly experience all the pleasures of top-down motoring -- with the convenience of one-button operation and automatic latching -- yet they will also be treated to cabin refinement on par with many luxury coupes. The quiet, draft-free interior is the result of several factors: a world-class sealing system, a fully lined and padded soft top, a 5 mm thick heated glass rear window and painstaking attention to detail from design house Karmann of Germany, who shared in the body development work.

The Jaguar XK8 is all car. The Jaguar XK8 epitomizes agility and balance, comfort and convenience. The XK8 is not a race ready sports car like the XKE was when it came out. In contrast to the aggressive masculine character of the Chevrolet Corvette, the XK8 exudes a powerful feline beauty, offers opulent sport luxury appointments and surrounds the occupants with rich wood and leather refinements. It is arguably one of the most beautiful automobiles in the world.

As an engineer, I believe that a fine luxury GT car like the Jaguar XK8 is as near to a living machine as we are likely to have for a while. It is not just basic transportation, but can be a super daily driver. I strongly encourage owners to take a deep interest in learning about their car's systems, care about their ongoing condition and see to their periodic needs. These cars are very well designed, have matured well over the 10 years they were offered, and I feel that each owner has an obligation to keep it in as good a condition as possible, for as long as possible.

## Engine

The all Jaguar designed AJ-34 4.2L closed deck (no valley pan) conventionally aspirated V8 engine has 5 main bearings and is both compact, light (weighing 441 lb) and strong running all the way to its 6400 rpm redline. Unlike its famous V12 predecessor however, its torque curve falls off considerably below 2500 rpm. The aluminum alloy cylinder block (2) mates to both a bedplate (3) and structural sump (4) providing durability and smoothness. In the Cosworth designed heads (1) variable intake cam phasing provides responsiveness with good fuel economy across a wide range of driving conditions. The conrods are Krebsoge sinter forged steel items, fracture split at the big end.

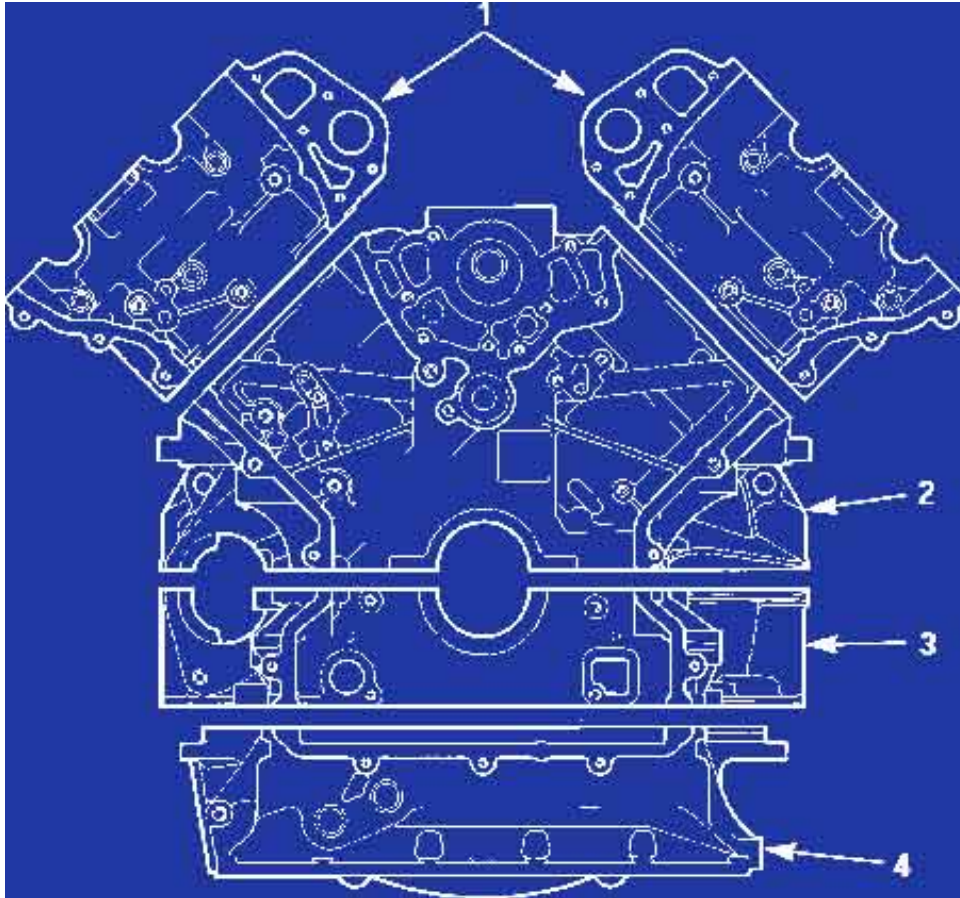

At the time of the XK8 launch in 1996, the AJ-27 incarnation of this engine assumed class leadership in weight, stiffness, low friction, specific power output and efficiency. The engine is now claimed to require no maintenance other than coolant, oil and filter changes for 100K mi. We discuss the associated engine systems in some detail in the following text and find their claim only partially true. Your attention to these concerns will ensure that you get good service from this fine engine. Its early 4.0L predecessors suffered from eroding Nikasil cylinder plating (due to the high sulfur in fuel at the time combined with excess moisture brought on by short trips) and several other weaknesses that have been addressed and pretty much solved in the 4.2L incarnation.

## Valvetrain

The AJ-34 incarnation of the Jaguar AJV8 uses tougher Morse chains (rather than simplex) and aluminum cased (vs plastic) primary and secondary cam chain tensioners. These more robust components evolved to better cope with the complex torsional load reversals that occur in the intake cams over the wide Variable Valve Timing (VVT) range of 48°. The supercharged engine doesn't have VVT, so it is easier on the chains and tensioners. Gun drilled camshafts, shimmed for life inverted bucket lifters and light (5 mm dia) valve stems reduce the valve train mass and cam loads as much as possible. The intake and exhaust valve axes are 28° apart, forming near ideal combustion chamber geometry for this high, 11:1 compression ratio engine and valve lift is 9 mm. Always use Premium Fuel Grades in these engines.

## Ignition

Ignition is via a NipponDenso 32-Bit electronic management system. An individual coil pack sits atop each spark plug. Cylinders are numbered 1, 3, 5, 7 starting from the front on the passenger side (Bank A) and 2, 4, 6, 8 starting from the front on the driver side (Bank B). Firing order is 1-2-7-3-4-5-6-8. These days it's not uncommon for spark plugs to last for 100K mi without fouling in today's unleaded fueled engines, but I recommend changing them at 50K mi because the electrodes still erode and new sharper surfaces create a more robust spark and more complete fuel charge burning. This ignition system is so strong that there is an SB asserting that plugs can be gapped at .052", but so far I've kept mine set the way they are right out of the box (around .040").

## Lubrication

When you buy a high performance roadster like the XK8, plan on using 8 qt of the finest Synthetic 5W30 oil you can afford and make a habit of oil/filter changes at anywhere from 5K to 7.5K mi intervals, any other practice being false economy. The oil filter is Fram PH5618 or equivalent. The steel lined engines burn just a wee bit of oil between these very conservative but prudent drain intervals, vs engines having Nikasil cylinder linings. I added the Fumoto F-106 (M14-1.5 thread) oil drain valve to make oil changes even easier. Never ever let your oil level get low -- if the low oil light comes ON, it's too late. Jaguar engineers did a very good job of designing the oil sump, windage tray and positioning the pump pickup, filter, pressure sender and oil cooler diverter valve. If the car is parked facing downhill, I have noticed a tendency for slight lifter noise lasting just a split second during cold start up. It probably has something to do with how the thin oil drains out of the heads and galleries. On flat ground or facing uphill it starts quietly.

## Cooling System

The engine has a split flow, low volume, high flow cooling system that brings the engine to operating temperature very quickly (<4 minutes), assuring a comfortable cozy cabin temperature, as well as contributing to ready drivability, low emissions and good fuel economy. The car has very little thermal insulation between the engine/transmission, so the cabin can easily get quite warm without the AC on. This makes the car cozy in the winter, but rather toasty in the heat of summer until the AC has been running for a few moments.

The coolant used is modern Organic Acid Technology ethylene glycol (Dexcool colored Red/Orange meeting WSS M97B44-D) and it is incompatible with other non-OAT mixtures (it forms an insoluble gel). The additive package in the coolant depletes slowly over heat cycles, so change the coolant out every 30K mi or 3 yrs, whichever comes first. Pressure testing the system is a good idea between 50K and 100K mi. Pressure flushing and flow checking can wait

until 100K mi and a new radiator somewhere between 150K and 200K mi. The plastic pressure cap and expansion tank with internal magnetic float level sender are pretty much toast by 75K mi. Original 4.0L coolant pumps had Black Nylon 6/6 impellers that degraded significantly in short order, causing overheated engines. The aftermarket responded with aluminum impeller equipped equivalent pumps. Meanwhile, back at the ranch, Jaguar fixed their impeller problem by changing to first Black PolyPhenylene Sulfide (PPS), then White PPS. The 4.2L all had improved pumps. There are claims that the aluminum impeller equipped coolant pumps will cavitate (a loss of pumping efficacy) unless an anti-cavitation additive (a surfactant) is added to the coolant to combat the phenomena, so it seems that staying with the new Jaguar pump P/N W0133-1609249 (includes the gasket) is your best bet. The good news is that these pumps are well made, will last for ~100K mi and are installed with the metal composite gasket. Three tabs in the gasket center fold up into the corresponding recesses around the outside of the pump throat. Problem is, the gaskets seem to leak before the pumps fail, so if you see coolant coming from underneath the pump, evident by greasy looking dirt build up in this area of the block (because boiled out glycol is sticky), the gasket is probably at end-of-life. A vestigial o-ring shown in some of the literature is not required, but its use may not be a bad backup when the gasket degrades. Look at the photo below to see sealing areas. Proper torquing of the pump attachment bolts is critical to a good installation. Change the serpentine belt and the thermostat at the same time as the pump.

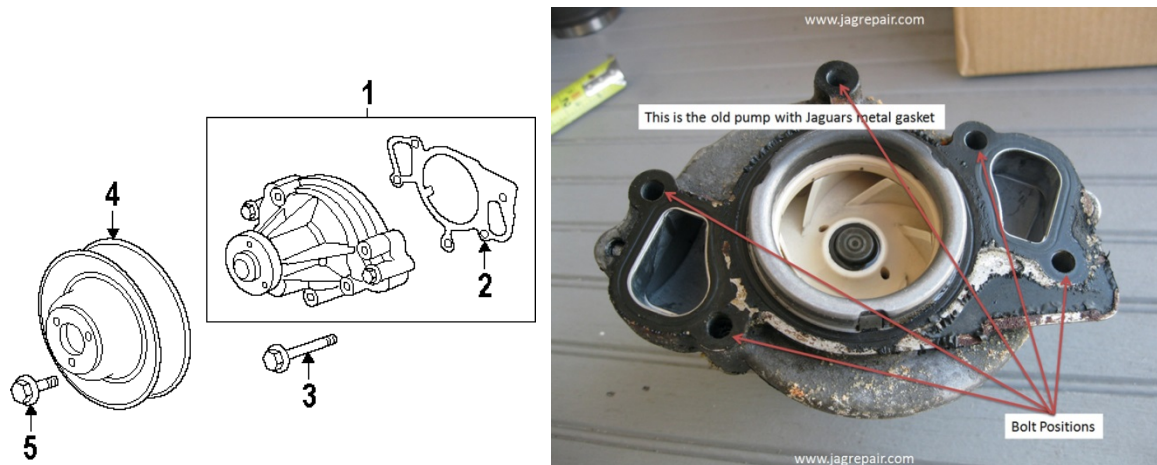

The 4.2L non-S/C thermostat P/N W0133-1655931 or AJ82697 is quite different than that used on the earlier 4.0L engines and so is the plastic plumbing tower assy in which it mounts. There is an improved aluminum version of the thermostat housing P/N AJ89484 in the aftermarket supply chain, and the thermostat mounts in it the same way. You can buy the entire plastic tower assy with thermostat installed (~\$100), just the plastic housing with the thermostat installed (~\$30) or the thermostat (comprised of 2 pieces and 2 springs) sold separately (~\$20). These plastic parts are considerably superior to the earlier phenolic parts on the '90s 4.0L engines. The installation of the four piece version thermostat is a little confusing for the first timer, as there are some erroneous pictures on the web. The correct arrangement is shown below in the left photo. The shaft pin end at the right fits into a hole in the thermostat housing and you compress the springs until you can rotate the two down angled tangs into their retention slots in the plastic housing. There is no jiggle pin in this thermostat, so rotational orientation is not an issue. There is a black polyurethane perimeter seal that fits in a slot in the thermostat

tower assy. It is a fairly robust looking seal P/N AJ8003525 (not a conventional o-ring), but should be replaced as long as you have the thermostat housing off.



Never ever let the coolant level get low in the expansion tank -- if the low coolant light comes ON, it's likely too late. The use of a 15 psi valve in the coolant expansion tank cap at the very top of the system combined with an atmospheric recovery tank located lower in the right wheel well is a great design, because whatever blows out of the expansion tank cap valve during operation theoretically gets returned to the system as it cools down. Make sure that the system is really doing its job by keeping the recovery tank  $\frac{1}{4}$  to  $\frac{1}{2}$  full of coolant at all times, otherwise the tubing "straw" can unport and not return any coolant. This can be difficult to gauge, as it is out of sight, out of mind and relatively inaccessible for filling. You can pull the side marker light out and use a penlight for a quick visual check.

What can be said about OEM coolant hoses and their clamps except that compromises get made for easy assembly. The hoses are relatively thin wall making them prone to heat softening, cut-thru and blow-off/out. Some of the smaller diameter hoses are expected to make rather abrupt turns in the overall complex plumbing scheme near the XK8 firewall and can flatten out or kink. Keep all of these hoses (and for that matter all rubber items except the serpentine belt) well coated with a good silicone oil spray for longest life. Don't waste your time and money on silicone sprays sold in most auto or hardware stores, the Industrial rated stuff is much better. I use the food grade low viscosity spray from CRC P/N 03040 for large area coverage and Easy Rider P/N RT 630A for small bushings, because it is thicker and clings better.

The cheap OEM "constant tension" spring steel clamps used are fast to install (with the right tool), compact and allow for expansion/contraction of the plastic hose nipples and compression set of the rubber hoses during heat cycles. But in an engineering sense they are a less than optimum choice for the critical task that they perform, keeping your engine from melting into a blob, and should be replaced well before reaching 100K mi, along with the hoses they retain. I don't know if they are just badly made of cheap steel and/or they have missed proper heat treating steps needed to ensure good long term spring characteristics. I prefer the stainless steel worm-screw clamp types that contact the hose for a full 360° and have a stack of multiple opposing Belleville washer pairs on the tightening screw shank to provide the constant tension feature. You can get these from most good auto parts outlets and McMaster-Carr. I also prefer more robust aftermarket hoses having a greater wall thickness. For most 1" ID and smaller cooling hose applications I prefer the fiber reinforced silicone hose often used on Police cars. I have used HPS, Verocious and Silicone Intakes hose firewall forward with good results on both cars and airplanes.

There is a hard plastic burp line running from a nipple atop the thermostat tower assy to the side nipple on the expansion tank. It is captured in a high heat area between the plastic engine cover and the intake manifold. I've had similar items overheat and break on BMWs, so I have replaced mine with a length of 5/16" [8 mm] ID reinforced silicone hose from Z1 Motorsports.

The drain plug P/N JLM20622 is on the lower right side of the radiator end cap facing aft and is a bit fiddly, what with a hard pipe partially in the way, preventing a straight shot at tightening it with your screwdriver. It has a rubber seal under the head and barbs on the end to retain it in the port when unscrewed. It is polyethylene plastic and threaded M10-1.5, so be careful to not strip it out when tightening or you will have slow seepage that might not show up on the ground.

## **Engine Compartment Heat Soak**

Due to the fact that the engine compartment is largely full of...well, engine...there is little room for anything else that doesn't help get the propulsion job done. Heat produced by the engine really needs to be forcibly ejected out of the compartment by moving the car spritely down the road, so stop and go traffic should be avoided. This car is made for the open road. As the hot engine is shut down, all that residual heat just bakes right into the surrounding structures of the car – the plastic and rubber parts too. The fans don't run when cold, run slow in series at low temp and run fast in parallel at high temp. The designers really should have programmed the cooling fan assembly controller to continue running the fans for several additional minutes following hot shutdown to reduce this tendency in our opinion. The point being, heat will have a lasting effect on the contents of the engine compartment, so inspect, maintain and act accordingly to replace heat affected items, lest they degrade over time in this environment and leave you stranded.

## **Serpentine Belt/Tensioner**

No matter what you have heard elsewhere regarding any other versions of these engines, the 4.2L conventionally aspirated engine in the 2003-2005 XK8 uses a six rib 91" serpentine belt, Dayco P/N 6PK2310 or equivalent and it generally lasts for somewhere between 50K and 100K mi. The tensioner spring is released using a 3/8" square drive breaker bar with a short piece of pipe to extend the handle. There isn't much room between the tensioner socket and the fan assembly. Replace the tensioner somewhere between 100K and 150K mi.

## **Air Induction Pipe/Cold Air Intake**

The single path conventional induction (Intake) system starts with an intake tube in the fender well feeding a large plastic air filter box, flowing into a pipe with integrated inline MAF sensor, then into a long straight section followed by two right angle turns to enter the throat of the throttle body. There are a few aftermarket Cold Air Intake kits (Torque Developments and K&N to name two) that may offer some small improvement in performance over OEM, but in our opinion, the designers should have chosen either a larger diameter single path system or just upped their game to a dual path system (like on the newer Infiniti G37s) getting ram air from both sides of the grille. The filter box is simple enough, but if you are careless when installing the filter, you might fail to get a good perimeter seal and the engine will idle rough and possibly stall as a result. I use the K&N 33-2190 filter because it is easy to clean and is less restrictive than paper over the long run. The pipe should be removed and examined for leaks regularly and care taken to reinstall it so that the bellows section doesn't flex unnecessarily and/or beat itself up against the Bank A engine cover. Heat soak is a problem here and the plastic will ultimately become brittle as a result. Carry some duct tape or Goop with you if yours is nearing end-of-life.

You will need to clean your MAF sensor every 100K mi or so using a commercially available solvent blended especially for this purpose. It can be unplugged and unscrewed from the intake pipe for easy access.



## Fuel System

The fuel tank rests behind the rear seat and contains a single pump and internal mesh particulate filter. This is a non-return line system, and the pump relies on the fuel in the tank for effective cooling, so don't make a habit of running the tank near empty. Conversely do not overfill the tank or you may foul the vapor canister system resting in the driver's side front wheel well behind the plastic liner. Fuse 5 in the boot fuse box supplies power to the fuel pump when the ignition is live, so pulling it and trying to start the car will reduce the pressure in the lines before getting down to changing the filter. The fuel filter is located in the left rear wheel above and ahead of the axle and should be changed out every 50K mi. It helps immensely if you remove the left rear wheel and get the rear of the car up on jack stands. The bracket should be unbolted from the car before releasing the hose fittings. The fuel will not continue leaking out of the hose(s) when the pump is not powered up, but I would still do this job with a low fuel tank level, just to keep the head low. Despite what most filter manufacturer's listings erroneously state, the XK8 fuel filter has changed substantially for the 2003-2005 XK8s. Instead of the threaded o-ring sealed ports of the original XK8 filters, the new filters have straight tubes with raised circular ridges halfway down to capture the radial clips in the Norma-Quick quick disconnects used on the fuel lines in this tight area. You need a special release tool (Performance Tool P/N W83152 sized for 5/16" [8 mm] fittings) to release these devices, unless you wish to damage their internal latching and sealing features. These tools are also available in a kit of different sizes (Performance Tool P/N W89338) for a wide variety of other automotive plumbing applications. Many fuel filters are supplied with supplementary plastic barbed fittings, but these are not needed for the XK8, so must be cut off and discarded. The Jaguar OEM P/N is C2S20977 or W0133-1657566 and that part has P/N 1X439155AA and "Made in Poland" stamped on it. That P/N cross references to Hengst H110WK, Mahle KL83, WIX WF8165 and Mann WK512, so you have many choices over a wide price range.



The fuel injectors have 12 very small orifices improving targeting, so you really need to keep the little buggers clean by adding fuel injector cleaner to a full fuel tank at every oil change. I prefer Berryman's Chemtool.

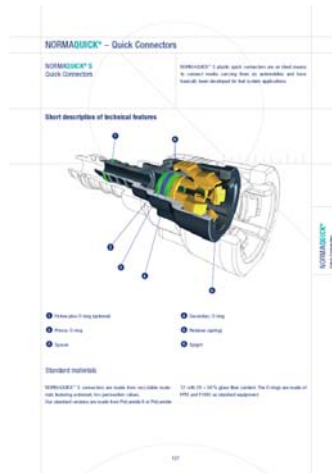
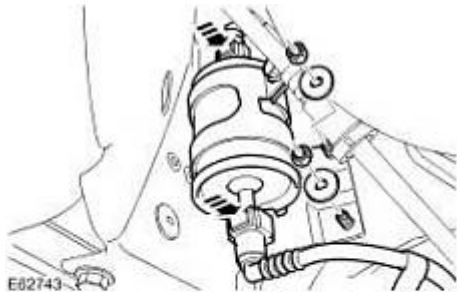

The gas cap magnet strength leaves a bit to be desired and will not always stay on the lid as designed, particularly as the plastic leash becomes stiff in the cold.

## Throttle Pedal and Throttle Body

The electronic "drive-by-wire" throttle gives smooth accurate power delivery, although an overly robust pedal return spring fights you to some extent. The throttle body is all new and improved for the 4.2L. There is a kick-down button at the limit of accelerator pedal travel that is supposed to be like kicking it into warp drive, but I have not had occasion to avail myself of it, since I don't race. There is a cable from the pedal up to the "throttle by wire" sender that stretches over time and can be snugged up again by pulling the clip and putting it back in a tighter groove (similar to adjusting brake or shifter cables on a bicycle).

## ZF 6HP26 6-Speed Automatic Transmission

This ZF transmission has a single planetary and dual planetary (Lepelletier) gear set providing for 6 forward gears and supporting engines having up to 444 lb-ft of torque. When placed in reverse, the computer limits the maximum throttle body opening to 18°. ZF claims this unit is filled with their Lifeguard6 "Lifetime" fluid, but general recommendations are that the fluid and integral filter/pan should be changed out every 50K mi or so. This basic gear box is very strong and used in many brands of luxury sedans and sports cars, so there are a lot of them around. The Type A plastic filter/pan of the Jaguar unit is available online CTSC P/N 1068 298 075 01. Always confirm that you can loosen the fill plug before you remove the drain plug. Early versions of this box used filter pan fasteners having T27 Torx driving recesses and apparently so many were getting stripped out during filter changes that ZF later switched to screws having T40 driving recesses. Check yours out in advance and if you still have the older screws, buy 21 T40s CTSC P/N 0736 101 486 01 and install them with a little anti-seize compound. The old and new screws will look exactly the same except for the difference in Torx driving recess size. Some recommend while you have the filter/pan off, that you also change the sealing sleeve CTSC P/N 0501 216 272 01.

Only about 6 qts of the total 10 qt fluid capacity are accessible during a static drainage (the rest is held in the torque converter), so if you do manage to empty out all 10 qt, you may extend the maintenance interval somewhat. Refilling involves pumping fluid, running the engine, shifting the gears, measuring fluid temperature, pumping more fluid, with the engine still running until it drips out and installing the fill plug all the while working around hot exhaust pipes. I had the shop use Pentosin ATF1 (clear/amber colored) fluid, but you can use the Jaguar packaged stuff if you prefer; as with any conversation about an esoteric subject, opinions are varied but run strong. This box incorporates Bosch Mechatronics, so keep in mind that there is considerable shift lag.

The OEM shifter knobs on many XK8s are pretty pedestrian so, if you need to up your game in this regard, check out the offerings of British Autowood online.

## **Driveline**

The steel pipe driveline is critically balanced with a Guibo (Elastomeric Flex Coupling) at each end. Any change-out of the Guibos needs to be done very carefully, one at a time, marking all bolts and not allowing anything to move until everything is back in their original positions. The Guibos have a directional arrow molded into them so make sure that you study everything before disassembly and that you have them the right way round during reassembly. If it were me, I would likely have the Jaguar shop do this work. Most Guibos are good for at least 100K mi, unless you are really hammering them hard by racing.



## **Differential**

There is no drain plug and the fill plug is in a nearly impossible to access location on the top rear of the differential. Because of this, the rear axle assy needs to be dropped several inches to do the lubrication service. The conventional wisdom seems to be that when the pinion seal leaks, to replace it and the differential fluid as well. Do this at the same time as you change-out the rear dampers to save repeat labor. Unless you have a special installation, there were no Limited Slip Differentials installed in these cars. The remaining service needed at the rear end is to jack up the car so that the rear wheels can rotate freely and grease the half-shaft U-joint zerk fittings four places every 15K mi, so moisture can't get in and they should remain in good condition for 150K to 200K mi.

## **Exhaust System**

The close coupled catalyts are a good design but they are bare steel, so rust badly, but really what can be done? Lambda sensors (upstream heated and downstream unheated) are pretty standard fare these days and the heated ones last from 100K to 150K mi, the unheated ones longer. The XK8 exhaust system is a five box stainless steel design. Jaguar designers went too far in reducing the music from this engine, but they were doing what they thought was best for the British Market. Furthermore the pipes tuck up so far above the rear axle that the bend angles are just too restrictive. There are several good aftermarket systems that replace the OEM system at quite a hefty price, because they too are stainless steel, but replacing just the two aft boxes with straight thru pipes can get you a better sound and a bit more power at the high end. If you feel the need for more, replace all four aft boxes or go for a full "Cat Back" system.

## **Front Cross Beam**

To prevent road surface noise and vibration from reaching the passenger cabin, the front suspension arms are not attached directly to the XK8 body. Instead, Jaguar engineers mounted the inboard ends of the upper and lower wishbones to a cast front cross beam, a structural member which spans the car from side to side. This intricate aluminum alloy structure is light -- a dozen pounds less than a steel beam would have been -- and very torsionally rigid. Jaguar further enhanced its durability by heat treating and applying a Dacromet protective coating to minimize the galvanic couple between the aluminum and the steel. The front suspension arms mount to this beam with bushings specially tuned to provide the proper degree of compliance when subjected to cornering loads. Besides the suspension arms, the forward portion of the engine's weight is carried by tuned hydraulic (liquid filled) motor mounts attaching directly to the cross beam.

## **Front Underbody Panel and Driveway Access**

The front of the car is pretty low (~5 inches at the front bumper fascia on my car), so adjust your approach angle when negotiating driveways and gutters and don't try to take them straight on. A 45° approach/departure with no braking dive is the best practice, or you will certainly end up scraping the plastic air dam and/or the paint on the underside of the bumper fascia.

## **Electrical System**

Of all the innovative technologies introduced by Jaguar in the XK8, there is one significant advance bound to remain unseen by owners: multiplexed electronics, not unlike the MIL-STD-1553B data bus protocol used in modern jet fighters. Though it provides a multitude of benefits, this system operates well and entirely out of sight. This multiplex system enables a high level of sophistication for the controls and features, plus advanced diagnostic capabilities that would not be attainable with a conventional electrical layout. Though relatively new to automobiles, multiplex technology is thoroughly proven in the aerospace industry, where it has simplified wiring harnesses, reduced weight and improved reliability.

In contrast to conventional systems, in which all features must be linked by dedicated hard-wired electrical connections, the multiplexed system controls the various vehicle functions over a network connecting electronic modules operating by low-current switching. The control commands are encoded at the output device, such as a switch or a sensor, to be utilized at a specific destination. This coding technique (in computer terms, a communications protocol) enables many messages to travel over a differential pair of wires rather than requiring scores of dedicated hard connections between modules. Shared usage of the communication pathway is very much like the system of roads our cars use every day: rather than providing each person in

a town with their own personal road from home to workplace, home to school and home to the supermarket, all drivers share main thoroughfares, connecting to the road system through their driveways, local streets and on/off ramps. Roadways can be shared by many users simultaneously, even though they doing different things, entering and exiting at different points, while adhering to rules governing lane usage and right of way -- a protocol system.

The shared pathway, or data bus, brings with it an enormous boost in efficiency. With operational information made available across the entire multiplex system, control refinement advances greatly. As an example, communication between the car's various electronic control modules enables the transmission shift program to be altered when the traction control system is activated, helping the driver maintain control under slippery conditions.

When the driver switches on the rear window defogger, that message is noted not only by the appropriate heating coil control circuits, but also by the engine management system. In this way, the increased electrical demand can be anticipated, and engine idle adjusted to compensate for increased torsional load of the alternator.

The use of relays thruout the car keeps switch contacts from having to carrying high DC currents. Switching high DC current is hard on internal switch contacts and produces pitting/arcing unlike that of AC current (since there is no zero crossing), but does complicate things when troubleshooting since they must act together in a given circuit. Having diagrams of your fuse/relay boxes, combined with a basic knowledge of which relay does what, could help out tremendously in a roadside emergency situation and allow you to swap out a failed relay in a critical circuit with one from a less critical circuit. There are several relay types and they are all color coded.

Jaguar recommends that any time you work on an area that has an electrical component, the battery should be disconnected before beginning work. Some cars apparently need codes to reset the radios and such, but I have had no such issues. After reconnecting the battery you do need to reprogram the window regulators. To do this, sit inside, close doors, raise a window and hold the button until you hear a click (a few seconds after closure), then lower that window all the way and hold for another few seconds until you hear a similar click. Raise it back up, open then close the door to confirm window drop and rise respectively. Confirm normal operation for each window/door. If the battery is left disconnected for long periods, the programming may be lost and require re-training. If it keeps happening, check the battery.

The OEM battery specified is a wet cell vented with a hose to the outside, so that is what I recommend for replacement. They are usually good for 5 yrs. Top off the electrolyte in each cell twice a year, using distilled water. AGM versions of this battery are available, but I have not personally evaluated the internal alternator regulator, so would need assurance from a Jaguar engineer that the charging system is in fact suitable for charging AGM batteries. It is my understanding that AGM batteries tend to be more sensitive to float voltage.

The alternator is a NipponDenso internally rectified/regulated unit producing 130A at ~14 VDC. That is a lot of power (500 to 800W during continuous operation just with normal systems running) for all the computers, stereo amplifier, GPS, lamps, pumps and fan motors. It gets cooled by forced air (in contrast to the water-cooled alternator in BMW V8s) from the underside of the car thru a fixed L-shaped tubular plastic duct. Cooling air is forced into this tube by the aid of a removable flared plastic duct (held to the steel cross bar by a single M5 bolt) P/N HJA4477AD. It gets removed to gain access for oil filter replacement, and is often misplaced or lost by careless service personnel. Its presence would be critical to alternator life, IF it were

correctly shaped like a NACA vent on an aircraft, but it is installed ass-backwards, so I'm not at all confident that it does as much as it could to keep the alternator internal diodes cool. If yours is MIA, you should probably get a new one. It tucks up above the tubular duct at the rear and clips into the radiator support at the front. For every 10°C cooler you can keep the diodes, you virtually double their life.

The battery in the key remote is CR2032 and the directions for battery replacement are in the Driver's Handbook. There is also a procedure to reattach your remote posted on the jag forum.

Along the sides of the engine compartment are wiring troughs that tend to collect all kinds of muck, so blast them clean with a pressure washer periodically. Along these same lines, the lower sill rails undershoot the wheel wells creating the ideal gravel trapping opportunity. Blast these clean periodically as well.

The molded polystyrene plastic end retainer tabs on the side marker lights (and other similar lamp fixtures) stress crack over time so, while they are still new, wedge some EPDM sponge rubber between the body and the tab for support and they will last much longer.

Why does any modern car have a power antenna instead of a dipole located elsewhere that won't collect crap from the air and jam up?

## **Suspension**

The sophistication of Jaguar's suspension design has long been among the most highly ranked of the marque's traits. The XK8 advances that tradition with its balance of handling prowess, cornering precision and ride compliance. The basic design relies on long-proven components -- independent, double-wishbones up front and an independent, control-arm layout at the rear. These have been developed to provide accurate wheel control and isolation of road harshness. Both front and rear suspension systems bolt to carrier assemblies which, in turn, attach to the body through elastomeric mountings. This construction method isolates road noise and vibration from the passenger compartment, yet provides the robust structure needed to maintain proper wheel geometry under hard cornering. Despite the good design, at low speeds the springs are stiff and produce a somewhat harsh ride over rough road surfaces like brick or cobblestone. At freeway speeds they seem just about right, although I find the front-end rebound damping just a bit light.

The XK8's front wheels are positioned by a short-and-long arm suspension system, a design which helps to maintain optimum wheel angles even at the extremes of hard cornering, resulting in better control and feel for the driver. A front anti-roll bar reduces body lean, a natural condition arising from the forces of cornering. The upper ends of the coil springs, which surround the dampers, mount directly to the body, reducing the load on the lower control arm bushings to improve durability. Front wheel bearings are a robust sealed double cartridge-type, greased for life and never require repacking.

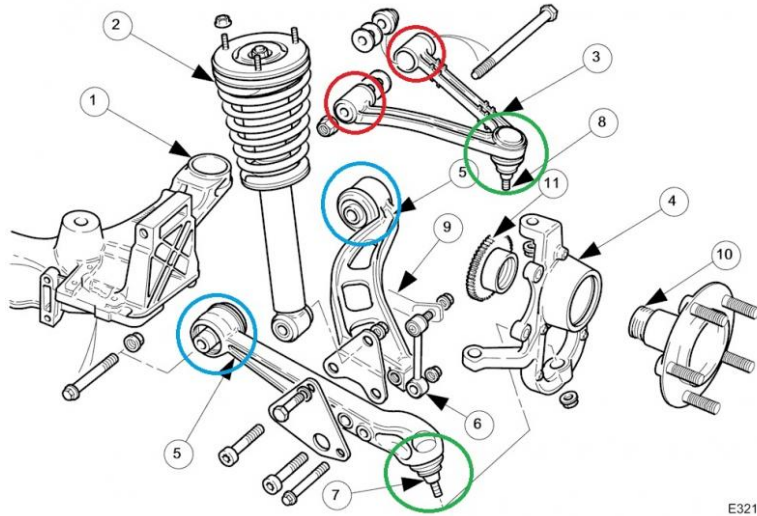

E3216f

The XK8 rear suspension design is closely related to that of Jaguar's XJR sport sedan. It includes anti-squat geometry, which reduces the natural tendency of the car to squat under acceleration. Like the front end, the XK8 rear suspension utilizes a control-arm design, with the coil spring and damper combined into a single unit. The spring is seated directly on the cast-iron transverse lower wishbone, not the damper, which reduces friction for better ride comfort and noise isolation. The half-shaft for each side serves as the upper suspension link.

The entire rear suspension is mounted to a steel carrier cross beam, which is then bolted to the body through bushings carefully selected for their ability to damp road harshness. In addition, the lower control arm pivots allow some deflection toward the rear when the wheel is subjected to the sharp impact of a pothole or bump. This design allows the XK8 to absorb road surface irregularities and helps prevent unwanted steering effects from the rear suspension in hard cornering. A rear anti-roll bar helps control body roll in cornering. A sturdy, one-piece differential strut, similar in design to the XJR sedan strut, is fitted to the rear of the differential housing to avert the possibility of axle tramp under hard acceleration. A slim spring compressor like the Sir Tools ST 9050 is needed for the rear end damper work.

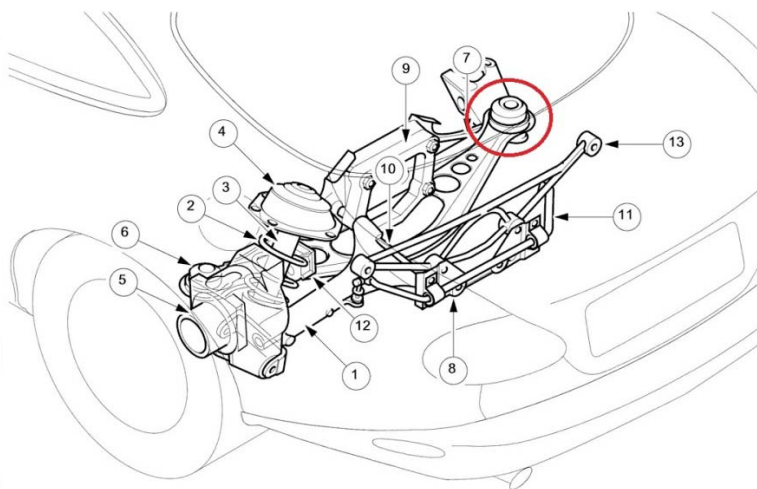

I am a big fan of Powerflex brand urethane bushings when the time comes to replace any of the aging OEM rubber bushings used thruout the suspension. Be sure to lube the inside surface of anti-roll bar bushings with the included grease or they will squeak.

## Steering

Continuing a long-standing Jaguar tradition, the XK8 steering system is a rack and pinion design and provides a suitable level of driver feedback and road feel without compromising its luxury-class smoothness and feel. Based on ZF Servotronic components, Jaguar's advanced steering system incorporates speed-sensitive variable power assist and a variable steering ratio. Speed-sensitive power assist: the hydraulic system that provides the steering's power assist delivers full boost at low speeds for easy parking but as vehicle speed rises, the assist lessens to give a well-weighted, confident feel to the steering at highway speeds. Due to the high assist at low speeds and the wide front tires, coming to stops over rippled/scalloped road surfaces can pull on the steering more than I would like. While some less sophisticated systems provide variable assist by cutting the flow of fluid to the steering rack itself, their effectiveness is hampered by the need to maintain sufficient flow for emergency evasive maneuvers at high-speeds. Using the hydraulic reaction principle to vary steering effort enables the XK8 to offer both world-class steering feel and power assist that is always available regardless of speed.

To further refine the steering feel during straight-ahead highway driving, the steering gear valve incorporates a Positive Center Feel torsion bar. As the name implies, the torsion bar twists a slight amount in operation, effectively programming an on-center position into the action of the steering valve at small steering angles, improving stability in conditions such as crosswinds. When the steering wheel angle exceeds a predetermined amount, the torsion bar reaches the end of its travel and the control of assist levels is assumed by the Servotronic system. Variable-ratio steering: the steering rack is a design in which the rate of road wheel movement quickens as the extremes of wheel travel left and right are approached. This makes parking less tedious yet provides an appropriate level of assist -- not overly sensitive to small steering wheel movements -- for excellent stability at highway speeds.

To reduce lateral friction forces on the front tires, the steering layout of the XK8 provides near-100% Ackerman geometry. The desirability of this design arises from the fact that, in a turn, the left and right front wheels describe circles of differing diameters (the tire on the inside of the turn describes a smaller radius circle than the tire on the outside of the turn). As a result, the tires need to point at slightly different angles, though they still must return to parallel alignment when the car is traveling straight ahead. If the steering geometry design does not achieve the correct differential in angles -- ideally 100% Ackerman -- the result will be coarse turning at low speeds and higher tire wear.

Why the steering wheel tilt and reach motors don't always work well in the Jaguar cars still mystifies me, unless there is something up with the electronics controlling the motors or some other contacts that the power is running thru that are not clean. Sometimes it works better when colder, sometimes better when warmer, but they are clearly completely functional individual parts that only seem to work correctly together on occasion. Perhaps there is a way of trimming the circuitry to work better, if in fact it's a current limiting circuit set too close to the starting current of the motors and erroneously shutting them down. When the motors just stop, the driver can respond by removing and reinstalling the ignition key and/or jockey the joystick on the side of the column and get the wheel into the correct position. Sometimes it won't work at all

and sometimes it works perfectly just moments later. Sometimes it's the tilt motor, sometimes the reach motor and sometimes both. It hangs up both on key install and key removal. I have replaced motors and position sensors and it stays flakey. The motors are good quality Bosch units used in many vehicles that don't have these problems, so there has to be another explanation. Maybe the contacts are not robust enough for DC and they pit readily.

The only other further comment I would make is that the tilt/reach system functionality seems to get worse if it is turned off and remains unused for a long periods, so the mantra seems to be use it or lose it.

## **Stability Control**

Standard equipment on the XK8 is automatic stability control (ASC), which reduces drive torque to the wheels by controlling the throttle position, ignition timing and fuel supply to the cylinders. An optional traction control (TRAC) adds brake intervention, using the anti-lock brake components to slow a spinning wheel.

In both systems, wheel spin is detected by the anti-lock brake sensors after comparing information supplied by all four wheel-speed sensors. Both systems may be manually canceled by pressing a switch on the center console to power out of deep snow or when using tire chains. Automatic stability control is operational at all speeds to enhance car control in slippery conditions. When wheel spin is detected, the anti-lock electronic control module calculates the engine torque level that can be utilized without causing the tires to slip, based on information from the vehicle's controller area network (CAN).

First, the throttle angle is reduced, but because the effect of this action is not instantaneous, two further measures are taken. Ignition timing is retarded (the spark plug fires later than normal) and fuel to the cylinders is cut off until the proper throttle position is reached.

## **Brakes**

The XK8 brake system is pretty much standard fare when compared with other modern luxury cars and uses the ATE Continental Teves MK25 4-channel DSC ABS unit. Unfortunately the OEM single pot single acting brake calipers are somewhat weak in their ability to act on the reasonably good sized disk to stop this car when you are going fast. I would like it very much if there were a good low priced option (<\$1K) vs the big chunk of change needed to upgrade to Brembos or similar. The braking ability is there if you get on the pedal harder, it's just not as responsive as I am used to. I use Drilled and Slotted Centric Power Stop Discs, Centric Semi-Metallic Pads (much less dust and much more bite than OEM pads and their stopping power only improves as they get warm) and Super Blue Racing fluid. Speed bleeders are available that make single person brake system bleeding easier.





ABS Control Electronics are in the black box attached to the hydraulic block and can be removed for repair separately from the block. Unfortunately the Jaguar brake fluid lines are dressed/formed down across the face of the box, so that it is unlikely that you can remove it without draining the system and undoing at least a few of the lines. On most BMWs this job is easier, as they do not route the hard lines in this manner. The connectors have a sliding end bar to lock the connectors in place and needs to be drawn out to disconnect the harness.

## **Wheels/Tires**

Chrome plated wheels (both original equipment and aftermarket) may experience separation of the chrome plating over time leading to slow escape of air from the tire. You need to get your tire guy to examine the plating all around the wheel in the bead seating areas during tire mounting and advise you, but this is a bad time to find out that you need a new wheel. Another possible way of assessing their condition is to look around the perimeter of the center growler badge. If you see chrome separating (a raised area) from the wheel in this region, then you can be assured that the chrome in the tire bead seating area may soon be compromised. Newer plated wheels that do not exhibit this concern are available. These wheels may be recognized, once the tire has been removed, by grey paint instead of chrome plating, across the inside of the wheel in the bead seating area. This issue is covered in an SB. Chrome wheels look really cool, but powder coated wheels are probably more practical.

Many XK8s had Pirellis from the factory. I like the Michelin Pilot Super Sports because they are dual compound, super sticky and much quieter but regardless, whatever tires you put on, you will generally get twice as much mileage out of the fronts as the rears. The rears will usually get you 20K to 25K mi depending on road surfaces and how hard you get on it. The low profile tires make the wheels prone to curb rash if you are careless in picking your parking spot, so stay well clear of curbs. When you do need to buy new wheels, the aftermarket is your best option. Many of the wheels used by Jaguar came from Keystone.

These cars came with a lot of different wheel/tire size combinations over the years, but I like the sizes I have, their grip is great in all conditions except freezing, they are quiet and they enter/exit turns well. It seems to me that Jaguar could have easily done a better job of either

zinc plating or painting the wheel hubs, as they become quite a rusty mess after only a few years of moisture getting in and around the growler caps. I hit them with a wire brush and then a light coat of VHT enamel from a rattle can when doing a brake job. Put some light lithium grease on the wheel center boss to keep wheels from sticking to their hubs.

Speaking of growler caps, the OEM ones that came on my car wheels looked like they were bought from the toy department at Walmart. There are much nicer looking ones available at the dealer and online in a variety of colors. Why would Jaguar “value engineer” their caps/badges to cheapen their appearance? Is there no brand pride left?

## **Windscreen Washers/Wipers**

The wipers are 21 in and have a short length of black urethane tubing traveling from fittings in the windscreen trough into the wiper arms to the arm mounted nozzles. The tubing seems to be of good quality, but they won't last forever, so watch them. The passenger wiper arm pivot is in the center of a very strong low pressure area creating a vacuum/venturi at the rear edge of the bonnet at speed (like blowing across an open bottle). The faster you drive and the longer you drive fast, the more this irresistible force wants to suck the plastic cap up and off of the wiper arm recess. It's Bernoulli's fault. I've lost two, so now I push it back down every time I see that it is riding up and I keep a spare. The driver's side doesn't have this problem, being that it is tucked deeper under the bonnet edge and therefore not at risk for the same situation. If you lose the cap P/N GJA8966AB, the nut and shaft will rust due to exposure and the tendency to trap water. The cap is made of polyethylene so no adhesive will stick well to it.

The washer fluid system lower filler neck to reservoir joint is a poor fit and will leak as the rubber grommet dries out over time. Remove the unit from the front left wheel well, disassemble the reservoir and filler neck joint. Remove the large rubber grommet and clean everything up well with Isopropyl Alcohol. Get some silicone aquarium sealant (it has better adhesive properties than some of the other caulking silicones) and butter up over the grommet outside groove and inside surface with sealant. Reinstall the grommet and neck and reinstall it in the car to cure in situ. It will never again leak at this joint, no matter how full you fill it.



## Soft Top

The decision to use a soft top -- rather than a hard panel -- was reportedly a deliberate XK8 styling choice. The XK8 soft top fabric and liner are attached to a folding aluminum framework engineered to provide a low "stack" height. You can operate it easily inside a fairly low ceiling garage. Operation requires pressing and holding a momentary rocker switch on the center console until a chime indicates first the start, then about 20 seconds later the completion of the soft top close or open action. Latching, unlatching and window operation are all automatically sequenced if you hold the button down long enough, and the soft top portion of the operation can continue while traveling up to 10 miles per hour.

Yet there is a problem with the soft top system, at least here in the states. Ignoring it may subject you and your passenger to the dreaded "Jaguar Green Shower" at an inopportune moment (I'm told usually on opening). Heat is most definitely a factor here in the lower 48, as these failures in the windscreen frame routed hydraulic tubing are virtually unheard of in the UK. The left photo below shows the 0.2 Ohm 100W pump voltage dropping resistor method and the right photo, the LSI pressure relief valve method. These methods are competing attempts to lower the peak pressure produced by the system. The valve solution is clearly superior, but at a greater acquisition cost and considerably more installation work. Use only Pentosin CHF11S (green synthetic fluid) in these pumps and if you have any other fluid (earlier XK8 model years used a different brown fluid that gelled in the small diameter lines over time), it must all be purged/flushed or bad things will happen. The Soft Top hydraulics are driven by a PowerPacker brand pump that spikes to 1600 psig worst case and the hose problem has been associated with hose types 303 and 363. It is unclear to me when/if these hoses were discontinued. You can read more at [JagRepair.com](http://JagRepair.com).

The final take-away from all of this discussion is that the system is designed to be very compact, therefore smaller diameter hoses, long hose runs small diameter cylinders and such, mean that hydraulic pressures must be quite high to do the major work of moving the soft top and actuating the latching mechanism over quite some distance. This is hard on the components and the environmental conditions that the system must endure may have been difficult for the UK designers to anticipate and test for. The pump portion of the system seems robust, but the plumbing itself and/or the termination of the fittings to the hose may both be suspect. We hope that your problems are few and easy to remedy, but it is what it is.



JagWrangler.com has a spiffy modification that, once installed in the driver's door, will allow you to remotely control soft top operation from the headlamp button of your key remote. For soft top external fabric protection, I use Raggtopp once or twice a year. Certain areas of the inner liner (probably a polyester material that looks and feels like fleece) will get sooty along with all of the rear seat surfaces (same as the radio antenna does) as you are driving around with the top down. I use a combination of Isopropyl Alcohol on a rag and a little steamer vac (a VAPamore MR-50 that I have modified so as to allow both the steam generator and vacuum motor to run simultaneously) to clean the liner periodically.

## Seating and Interior

The OEM separate headrest type seats are somewhat weak for a luxurious sports car of this caliber and are just barely adequate to the task of driving, but not cornering. Due to quirks of their design, they also have a tendency to develop internal squeaking, groaning and creaking over time with occupant movement. I'd love to know how to fix it. There is an SB for a fix to the seat riser end float. The seat position control electronics sit in a plastic enclosure under the front of the seat bottom and after years of impact the cases or lids can crack and rattle. There is an SB that offers a replacement lid P/N C2N3565. The range of seat motion is somewhat limited for long legged drivers and the seat can only go back so far as the rear seat will allow. The seat bottom heaters work well but are superfluous in a car already this cozy. Top up, there is just enough head room and I'm 6' 2" but longer in the trunk and seat base height is all the way down both front and back.

The headrest drive cables can be troublesome, but there is an SB fix and Reverend Sam (fellow Pastafarian) has a video on YouTube describing correcting the sheath length so that the internal cable more fully engages the drive mechanisms at both ends. Use a good quality 1/2" starting diameter semi-rigid wall heat shrink tubing having an adhesive inner liner (meeting AMS-23053/4-105-0) when doing this SB and this fix will last forever. The headrest automatically lowers when the seat back is tilted forward. This feature is controlled by micro-switches. The side lever release allows the seat back to tilt forward, actuating the tilt micro-switch and running the motor to retract the headrest. When the seat backrest is returned to the normal driving position, the seat latch micro-switch causes the headrest to return to its programmed position. Be aware that these micro-switches are mounted externally on the seat frames adjacent the driveshaft tunnel and can easily get dislodged by careless vacuuming of the interior.

The driver's seat lumbar bladder was in the wrong vertical position for my back, but it can be easily adjusted by disassembling the rear of the seat and changing the tie wrapped height of the bladder to a rubber mounting web.

The cup holder is completely laughable and a rebuild kit is available, but was there really no room for a proper one? The console armrest "goody tray" cover foam gets compressed and the leather starts to ripple and look bad. Better foam is probably a good retrofit. Sam's got this covered in a video too.

Convertibles get dirty inside because, if you are like me, you will put the top down often. I use Lexol spray or wipes to clean and Surf City Garage Voodoo Blend Leather Rejuvenator to treat leather. The side of the side back will get rubbed raw by your butt getting in long before any other leather surface starts to show wear so maybe protecting this area with pad or something similar is a good idea. New seat skins are available from GAHH, but are expensive. The best plastic treatment is Meguiar's Ultimate Protectant (much better than Armorall).

Another weak area is on the door weather stripping, but only in two areas. The rubber can split where the window glass edges exit at the front just above the mirror and at the rear just above the door latch. The cost of replacement is significant and installation laborious. There is a solution that has worked for me. For the front split, just trim off the split sharp corner and smooth it into a more rounded corner with a Dremel tool sanding drum. For the other end, go buy some Permatex Black Rubber Sealant #80338. Put some in a non-waxed paper mixing cup, add a little Acetone to thin it out to brushing consistency and make sure it's mixed real well. Clean the rubber area adjacent to the repair area using Acetone. Using an acid brush, or similar disposable brush, apply the mixed liquid in thin multiple coats. If you need to, use masking tape to hold the split area together and drip some of the rubber mix down the inside of the tape. Let setup overnight and reapply as necessary until the area looks like new.

On the knee bolster is a little plastic grille and behind this is a thermocouple/thermistor for the climate control system. This gets dirty and can affect the system's ability to determine the ambient temperature of the interior used to calculate how to throttle the A/C. A little bit of dash disassembly is required using plastic pry tools and don't break anything. Clean it with a little Isopropyl Alcohol and reassemble.

I like dash mats in all of my vehicles and CoverKing makes a good one. Just make sure that you get the Velcro anchors stuck well to the glare shield surface, as having a dash mat fly up in your face on a convertible at speed could be really dangerous. I found that the acrylic adhesive didn't work well (it melts in the heat), so ended up using Acetone as a cleaner and contact cement to bond the anchors down.

There is a microswitch inside the door on the latch mechanism that can degrade over time and there is a fix for it, so when your door doesn't sense that it has been closed and bump the glass up, and you have already reset the window glass limits, it may be time for a new switch.

Regarding "popping" door hinges, the hinge foot attached to the body shell shears from one tangent point of the bolt clearance hole to the opposite tangent as the door is opened and closed. It is basically just sliding back and forth on the slightly loose bolt, because Jaguar doesn't bother to install a locking device to preventing the bolt from backing off. It normally occurs on the driver's side first because that's the door that always gets opened. Remove the bolt and reinstall it using some Loctite 242 and retorque securely (about 5 ft-lb, 60 in-lb), and problem solved forever.

## **Restraints**

Extensive safety considerations are engineered into the XK8. There is a sophisticated onboard system constantly assessing the occupancy/position of those in the cabin and providing for optimum deployment of the airbags under a wide variety of conditions. Dual seat bolster airbags are provided for the driver and front passenger, along with pyrotechnic seat belt pretensioners to take up seat-belt slack during impact.

## **Lighting**

I have the OEM Halogen Headlights and find that they and all of the other lighting fixtures are quite good under all conditions. The headlamp lenses are in fact glass (and quite sharp when broken) and prone to major road/rock/FOD damage. I recommend that you apply the X-Pel 3M protective film appliques (~\$50) to the glass ASAP or you may be buying a \$400 lens assy sooner than you would like. The kit I bought had precut pieces to cover both the glass headlamp fixture lenses and the fog/driving lamps.

## Pollen Filters

There are no interior pollen filters installed under the bonnet of any USA vehicles and seriously, do they even work on convertibles?

## Protection

If your XK8 is a daily freeway driver, you need to protect the front end against FOD chips. Sadly, the P/N C2S4496 Front Bonnet Protector (black vinyl bra) was never redesigned for the front end changes made in 2003, so it ends up being a marginal fit around the driving lamps and the lower scoop areas. The intake mouth in the grille is also deeper, so the plastic clips don't reach. You will need to make your own bungee attachments to adapt it to the 2003 – 2005 range, preferably scallop the lower portion to clear the bottom intake and re-hem it so as not to block air flow to the lower radiating fins. You will also need to make some loops (I formed some of .032" dia stainless steel aircraft safety wire) to hold the bra corners up and back using the fir tree clips for the wheel well liners as firm anchor points. Clear protective film application to the front of the car is also available from custom installers. Other protectants may be needed in different climates. Noxudol 750 anti-corrosion treatment or similar cavity wax should be applied on and/or into all places you can get to with the included snaky hose that might be subject to moisture ingress and road salt effects. Removing the plastic front wheel well liners for access and applying in these areas would be a real good idea. Just get the car on a lift, look for areas that are prone to rusting and apply it (just don't get in on braking surfaces or things that need to move freely without binding).

## Lamps

Position	Sylvania	Generic
• Front Low Beams (2)	H1	(55W Halogen)
• Front High Beams (2)	9005	(65W Halogen)
• Front Parking (2)	2825	(5W)
• Front Turn Signal (2 YEL)	7507	(Y21W)
• Front Fog/Driving (2)	H1	(55W Halogen)
• Front Side Marker (2)	2825	(5W)
• Door Puddle (2)	2825	(5W)
• Interior Panel (4)	194	LED
• Interior Footwell (2)	2825	(5W)
• Interior Dome (1)	6411	(10W)
• Interior Map (2)	2825	(5W)
• Rear Side Marker (2)	2825	(5W)
• Rear Tail/Stop (2)	7528	(21W/5W)
• Rear Center (2 Spare)	7528	(21W/5W)
• Rear Turn Signal (2 YEL)	7507	(Y21W)
• Rear HMSL (1)	2825	(5W)
• Rear Back Up (2)	7506	(21W)
• Rear Fog (2)	7506	(21W)
• Rear License Plate (2)	2825	(5W)
• Rear Boot (2)	6418	(5W)

Halogen lamps are available in various enhanced performance versions and should always be used in pairs so that the color and intensity of the beams on one side of the car are substantially similar to the other. All other lamps are available in Long Life or LED equivalents. It's a

personal thing, but frankly, I find LEDs used in brake light applications really irritating/startling, because they come on so abruptly, vs incandescents. The XK8 Driver's Handbook page 6-17 is incorrect regarding the proper lamps fitted as Fog Lamp, Dipped (Hi) Beams and Main (Lo) Beams. The above listing is correct. It was nice of Jaguar to give us an unused spare lower center position lamp that can be traded out in emergencies for a failed rear/stop lamp in each fixture.