

Using the Options menu

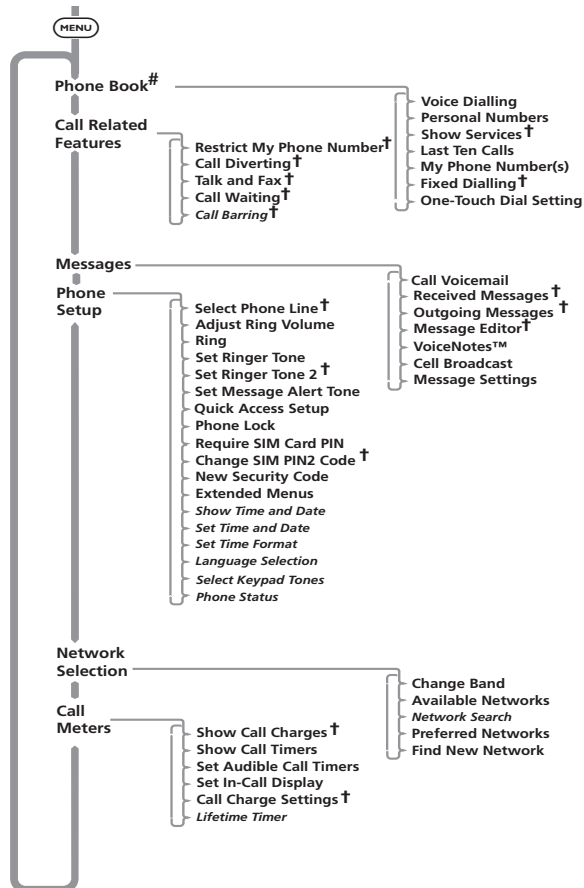

Menu Navigation



Items shown in *italics* are available only when **Extended Menus** are switched on.

If your service provider has added their own menu, the Phone Book menu will not be the first item in the Options menu.

† Availability depends on the type and settings of the SIM card and/or your subscription to these services.

9-2 Handset options menu

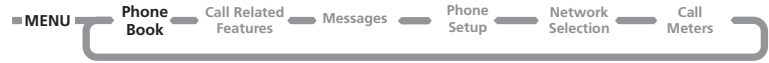

The Phone Book menu

Menu Navigation



† Availability depends on the type and settings of the SIM card and/or your subscription to these services.

‡ Only available for Phone Book entries that are in phone memory.

Phone Book

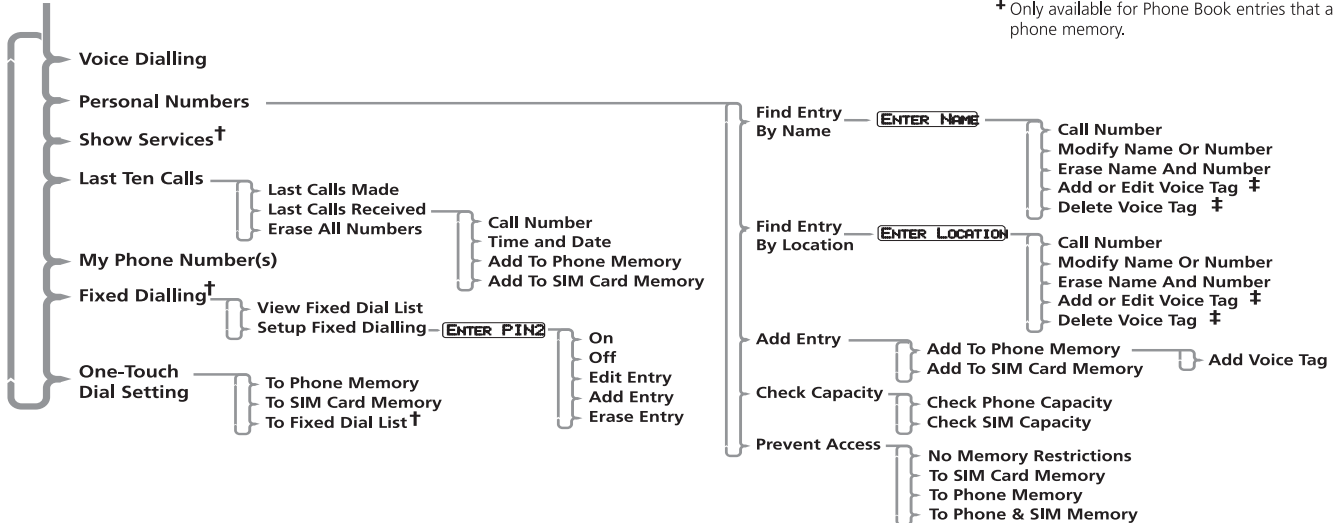

☞ If your service provider has added their own menu, the Phone Book menu will not be the first item in the Options menu.

OK What is the Phone Book?

You can store names and telephone numbers as entries in an electronic 'Phone Book'. These entries are stored in the *Personal Numbers list* in your phone or SIM card's memory, and in the *Fixed Dial list*¹ on your SIM card. Once stored, a number can be quickly retrieved and dialed.

Your phone can store 100 entries and the SIM card can store up to 200 entries depending on the capability of your network operator, in the Personal Numbers list. The number of SIM card entries will vary depending upon the type of SIM card issued by your Cellular Service Provider.

You can also store up to 40 entries in a Fixed Dialling list if you have this feature. Fixed Dialling allows you to limit use of your phone to particular numbers, or, if you wish, to country codes, area codes, or other prefixes of your choosing.

Each Phone Book entry comprises:

- A telephone number. Up to 32 digits can be stored, but this is reduced to 20 digits for SIM card locations.
- A name. Up to 16 characters for phone locations. Up to 50 characters for SIM card locations, but typically 10 or less.
- A location label – from 1 to 255 in your Personal Numbers list, or 1 to 40 in your Fixed Dial list.

Postscripting

This allows you to make use of area codes and other prefixes previously stored in your Phone Book when making a call.

To use postscripting, select the Phone Book entry containing the prefix and then simply enter the rest of the number and press **OK** to make the call.

You can also use postscripting if you want to call a number similar to one you have stored in your Phone Book. Retrieve the number from the Phone Book, delete the relevant digits and then enter the new number.

 Postscripting a number does not overwrite the entry in the Phone Book.

 Postscripting is not available when accessing the Phone Book using the Smart button.

1. Availability of the Fixed Dialling feature depends on the type of SIM card you have.

9-4 Handset options menu

How to enter alphabetic characters

The **0+**, **1**,, **8TUV** and **9WXYZ** keys are used to enter alphabetic characters, for example when storing names in the Phone Book or when creating messages.

For example, if you press the **5JKL** key, the first displayed character will be J. If this is not the required character, then you can press the same key again to show K. Another press will display L, another... ..will display 5. Your phone will continue to scroll through the characters available on the selected key with each new key press.

A long press of any of the keys will switch all the characters to lower case, a second long press will switch back to upper case.

To enter the next character press the appropriate key. If, however, the next character is on the same key as the previous character you will first need to press the **#>** key. Pressing the **#>** key a second time will produce a space.

If a mistake has been made, you can go back to the incorrect character by pressing **<***.

Characters can be removed from the display by pressing the **C** key.

The character before the cursor (■) is the character which will be deleted.

Press the **OK** key to store the information.

Available characters

Press the appropriate keys to get the following characters:

1	Space . 1 ? ! , @ _ & : " () ' & i % £ \$ Space . 1 ? ! , @ _ & : " () ' & i % £ \$
2ABC	A B C 2 Ä Å à å Æ Æ Ç a b c 2 ä å à å æ æ ç
3DEF	D E F 3 Æ É è Æ d e f 3 æ é è Æ
4GHI	G H I 4 Γ i g h i 4 Γ i
5JKL	J K L 5 Å j k l 5 Å
6MNÖ	M N O 6 Æ ö ø ò Ω m n o 6 æ ö ø ò Ω
7PQRS	P Q R S 7 Π ϑ Σ p q r s 7 π ϑ σ
8TUV	T U V 8 θ ù Û t u v 8 θ ù Û
9WXYZ	W X Y Z 9 Ξ Ψ w x y z 9 ξ ψ
0+	+ - 0 x * / = > < # + - 0 x * / = > < #

The top line for each key shows the upper case characters, the lower line shows the lower case.

Voice Dialling

Select this option to call any phone number that has a Voice Tag. The phone prompts you to press the smart button (Ⓞ). See **Using Voice Activation** on page 8-2.

Personal Numbers

The Personal Numbers sub-menu is used for creating and managing your list of personal numbers.

Find Entry By Name

 Press Ⓞ and say the Voice Tag name after the tone. See **Using Voice Activation** on page 8-2 for more information.

 Press Ⓞ and use the volume button to scroll to the stored number, or press the appropriate digit key to skip to a particular letter. To make the call, either hold down Ⓞ for 1.5 seconds or press **OK**.

This option is used to select a telephone number from a list of alphabetically sorted Phone Book names.

Once selected, this option will display the message `Enter Name`. You can enter a maximum of three characters from a name but you do not need to enter all three characters to begin a search.

The Phone Book entries will be searched and the first alphabetically matching entry will be displayed.

If there isn't a name matching your entry, the nearest alphabetically matching entry will be displayed.

If you do not enter any name information, the first alphabetical entry will be displayed.



If there are no names stored, `No Names Stored` will be displayed.

To display adjacent Phone Book entries use the `↕` key. When the desired name is displayed press the **OK** key to select it. The phone then enters the options sub-menu for `Find Entry By Name`. See **The options for 'Find Entry By ...'** on page 9-6.

9-6 Handset options menu



Find Entry By Location

 Press  and say the Voice Tag name after the tone. See **Using Voice Activation** on page 8-2 for more information.



This option is used to select a telephone number from a list of numerically sorted Phone Book locations.



Once selected, this option will display the message **Enter Location**. You can now enter a location number. If the entered location is not valid, a timed message **Range 1-XXX** will be displayed and the phone will return to the **Enter Location** menu item.

The Phone Book entries will be searched and an entry will be displayed.

If you enter a location number for which there is no entry, **Location Empty** will be displayed and the nearest non-empty location will be selected instead.

If you did not enter a location, the first numerical entry will be displayed.

If there are no numbers stored, **No Numbers Stored** will be displayed.

To display adjacent Phone Book entries use the  key. When the desired name is displayed press the  key to select it. The phone then enters the options sub-menu for **Find Entry By Location**. Refer to the next heading, **The options for 'Find Entry By ...'**

The options for 'Find Entry By ...'

Once a Phone Book entry has been selected, it can be called, modified or deleted.

If the Phone Book entry is in phone memory, you can also add, edit or delete the Voice Tag.

Call Number

This option is used to call the selected Phone Book telephone number.

Modify Name or Number

This option is used to change the selected Phone Book entry.

The entry's current telephone number and name will be presented, in turn, for modification. You can accept the current settings or modify as required.

Erase Name and Number





This option is used to erase the selected Phone Book entry.

Simply press the  key when the phone displays the message **Erase Name And Number**. The option will display the timed message **Erased XXX** and then return to the **Find Entry** menu item.

Add or Edit Voice Tag and Delete Voice Tag

Use these options to add, edit or delete the Voice Tag for the Phone Book entry. See **Using Voice Activation** on page 8-2.

Add Entry

 Press . Select the Quick Access feature ( Add to SIM? or  Add to Phone?) or after the tone, say the Voice Tag name. See **Voice Activation for Quick Access Features** on page 8-5.

This option is used to add (store) entries to the Phone Book. You can choose to add the new entry to either the phone or SIM card memory locations.

Add To Phone Memory, Add To SIM Card Memory

Once you have selected the destination of the new entry, you will be asked to enter the telephone number, name and location number of the new entry.

The last telephone number displayed will be presented by default; it can be used or discarded as required.

If the entered location is not valid, a timed message Range YYY-ZZZ will be displayed and the phone will return to the Enter Location prompt. If the chosen location is currently used by another entry, you will be asked for confirmation that the location can be overwritten.

If you do not supply a location number, the next available location will be used.

When the new entry has been entered, a timed message Stored XXX will be displayed.

Add Voice Tag

If you add a Phone Book entry to the phone memory, the Add Voice Tag? prompt appears after Stored XXX. Press  to add a Voice Tag. See **Using Voice Activation** on page 8-2.

Check Capacity

This option is used to check the number of free Phone Book entries in the phone or SIM card memory areas.

Check Phone Capacity, Check SIM Capacity

Once selected, a timed message XX Unused Locations displays the requested information.

Prevent Access

This option enables you to prevent access to the Personal Numbers list.

 You cannot record a Voice Tag if you have set Prevent Access To Phone Memory.

9-8 Handset options menu





To SIM Card Memory, To Phone Memory, To Phone & SIM Memory, No Memory Restrictions

You can prevent access to all entries in the SIM card memory, the phone memory or both the phone and SIM card memory. To cancel all access restrictions use the No Memory Restrictions option.

When you change the restrictions, you will be requested to enter the Security Code before the change is made.

Show Services



 Press . Select the Quick Access feature ( Show Services?) or after the tone, say the Voice Tag name. See **Voice Activation for Quick Access Features** on page 8-5.

This option displays a list of phone numbers and services provided by your Cellular Service Provider.

 Availability depends on the type and settings of the SIM card, and/or your subscription to this feature.

Last Ten Calls

These options allow you to review your most recently used phone numbers. Depending on the option you choose, you can then redial a phone number, store a phone number in your phone book, or erase all of the phone numbers.



After you select an option, use the  key to scroll through the list of phone numbers. Press the  key to proceed.

 You can use postscripting to modify a number once you have retrieved it from either of the Last Ten Calls lists.

Last Calls Made

Select this option to redial the phone number of any one of the last ten calls made.

Last Calls Received

 Press . Select the Quick Access feature ( Received Calls?) or after the tone, say the Voice Tag name. See **Voice Activation for Quick Access Features** on page 8-5.

Select this option to redial the phone number of any one of the last ten calls received. In addition, you can add time and date information to one call, and you can store any of the phone numbers in your phone book.

 You will only see numbers in the Last Calls Received list if you have Caller Line Identification.

When you scroll through your last ten calls, each call appears with a call position number, for example: 1+, 2-, 3+ ... 10+. A + symbol indicates that you answered the call. A - symbol indicates that you did not answer the call.

Press the  key to select a phone number. You can then scroll through and select one of the following options:

Call Number

Select this option to call the phone number.

Time and Date

Select this option to add a time and date stamp to the phone number. Press the **(OK)** key to accept the date and time stamp and return to the list of last ten calls received.

Add to Phone Memory

Select this option to add all the phone number details (including any details you have added) to your phone memory. If the name in the received call does not appear in your phone book, the phone prompts you to **Enter Name** and **Enter Location**. For further details, see **Add Entry** on page 9-10.

Add to SIM Card Memory

Select this option to add the phone number details (including any details you have added) to your SIM card memory. If the name in the received call does not appear in your phone book, the phone prompts you to **Enter Name** and **Enter Location**. For further details, see **Add Entry** on page 9-10.

Erase All Numbers

This option erases all the numbers stored in your Last Ten Calls Made and Last Ten Calls Received lists.

 The Last Ten Calls lists will be erased when a new SIM is inserted in the phone.

My Phone Number(s)

This option allows you to access your cellular phone, fax and data numbers so that you can retrieve or modify them when required. For example, if you have difficulty remembering your cellular phone number, store it with the name **My Phone** and then you will be able to retrieve the number as required.

The My Phone Number(s) list is stored on your SIM card.

When you select this item, the first location will be displayed. Use the  key to scroll through the phone numbers stored.

To enter or change a number, scroll to the location and press **(OK)**. You will be prompted to enter a phone number and then a name. Press **(OK)** to store the information.

 Depending on your Cellular Service Provider, you may find that one or more of the entries in the My Phone Number(s) list will have been defined. You may not be able to change these predefined entries.

9-10 Handset options menu

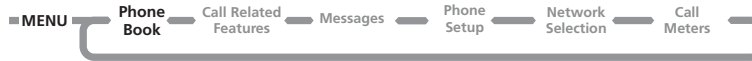

Fixed Dialling

 Availability of the Fixed Dialling menu depends on the type of SIM card.

This feature allows you to limit use (typically third-party use) of your phone to a predefined list of telephone numbers or, if you wish, to a list of country codes, area codes, or other prefixes of your choosing.

When Fixed Dialling is switched on, the only numbers that can be dialled from your phone are those stored (or whose prefix is stored) in the Fixed Dial list. If you attempt to dial any other number (apart from an emergency number), the message **Restricted** will be displayed. You will not be able to make fax or data calls.

To make a call when Fixed Dialling is switched on, either dial the number manually, or select it from the Fixed Dial list and press **(OK)**.

Up to 40 entries can be stored in the Fixed Dial list. The list is stored on your SIM card.

 **This option may be affected by the Call Barring setting.**

View Fixed Dial List

This option allows you to scroll through the numbers in the Fixed Dial list. When you find the number you want, press **(OK)** to make the call.

Setup Fixed Dialling

This option allows you to switch Fixed Dialling on or off and to enter or change entries in the Fixed Dial list.

You will be prompted to enter your PIN2 security code when you select this option.

On

Switches fixed dialling on.

Off

Switches fixed dialling off.

Edit Entry

Modifies or clears an entry in the Fixed Dial list. When you select this option, the first non-empty location in the list will be displayed. Scroll to the entry you want to change and press **(OK)**. You will be prompted to edit the phone number and the name. To erase the entry, press **(C)**.

Add Entry

Adds a phone number and name to the Fixed Dial list. When you select this option you will be prompted to enter the phone number, name and a location number. If you do not specify a location number, it will be stored in the next available location.

 When setting up your Fixed Dial list, you may want to reserve the first nine locations for phone numbers you wish to One-Touch Dial. See also **One-Touch Dial Setting** on page 9-11.

Erase Entry

Erases a phone number and name from the Fixed Dial list. The first entry in the Fixed Dial list will be displayed. Scroll to the entry you wish to delete and press **OK**.

One-Touch Dial Setting

This option allows you to specify which Phone Book list can be One-Touch Dialed.

To Phone Memory

Switches One-Touch Dialling to your Personal Numbers list stored in phone memory (locations 1 to 9).

To SIM Card Memory

Switches One-Touch Dialling to your Personal Numbers list stored on your SIM card (locations 101 to 109).

To Fixed Dial list

 This option is only available if you have Fixed Dialling.

Switches One-Touch Dialling to your Fixed Dial list (locations 1 to 9).

9-12 Handset options menu

Call Related Features menu

Menu Navigation

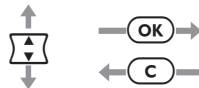

Items shown in *Italics* are available only when **Extended Menus** are switched on.

† Availability depends on the type and settings of the SIM card and/or your subscription to these services.

Call Related Features

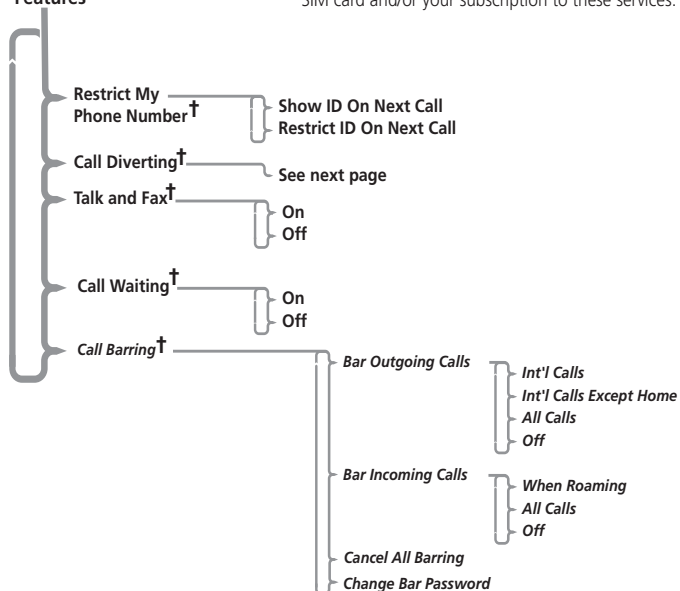

Restrict My Phone Number

'Restrict My Phone Number' is a network feature. You will need to subscribe to one of the two Caller Line Identification restriction features with your Cellular Service Provider.

Show ID on Next Call

Your phone number is sent with the next attempted call, after this your phone number will not be sent until you reselect this option.

Restrict ID on Next Call

Press . Select the Quick Access feature (Restrict My ID?) or after the tone, say the Voice Tag name. See **Voice Activation for Quick Access Features** on page 8-5.

Your phone number will not be sent with the next attempted call, after this your phone number will be sent with calls until you reselect this option.

OK Call Diverting

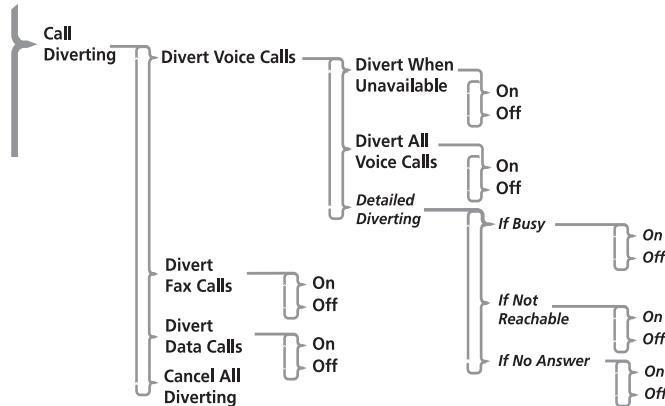

Call diverting is a network feature. If your phone is unavailable, or you do not wish to receive calls, incoming calls can be diverted to other phone numbers.

This option can be used to:

- Divert all incoming Voice calls unconditionally.
- Divert incoming Voice calls whenever your phone is unavailable, busy, not reachable or not answered.
- Divert incoming Fax calls.
- Divert incoming Data calls.
- Reset all diversion options to off.

You cannot change the call divert settings when you are out of network coverage.

After selecting any of the call divert options there will be a short delay while the phone asks the network for the current setting.

Divert Voice Calls

This option will allow you to set your phone to *Divert When Unavailable*, *Divert All Voice Calls* or *Detailed Diverting*.

Divert When Unavailable

This option will enable you to divert all incoming Voice calls to a single number, whenever your phone is unavailable.



The option has two settings, *On* or *Off*.

If you change the setting to *On*, you will be asked to enter a diversion phone number using the digit keys.

Setting “Divert When Unavailable” to *On* will have the same effect as setting all “Detailed Diverting” options to *On*.

When *On*, Divert When Unavailable takes priority over detailed diversion settings.

Divert All Voice Calls

 Press . Select the Quick Access feature ( Divert On/Off?) or after the tone, say the Voice Tag name. See **Voice Activation for Quick Access Features** on page 8-5.

This option will enable you to *unconditionally* divert all incoming Voice calls to a single number.

The option has two settings, *On* or *Off*.

If you change the setting to *On*, you will be asked to enter a diversion phone number using the digit keys.

 When *On*, Divert All Voice Calls takes priority over all other Voice call diversion settings.

Detailed Diverting

These options will enable you to divert Voice calls to different numbers, depending upon the current status of your phone.

Each of the following detailed diverting options operate in the same way.

Each option has two settings, *On* or *Off*.

If you change the setting to *On*, you will be asked to enter a diversion phone number using the digit keys.

 Detailed diversion settings are ignored while Divert All Voice Calls or Divert When Unavailable are *On*.

If Busy

This option will divert incoming calls if your phone is busy.

If Not Reachable

This option will divert incoming calls if your phone cannot be contacted by the network.

If No Answer

This option will divert incoming calls if you do not answer the call.

Divert Fax Calls

This option will enable you to divert all Fax calls to a single number.

The option has two settings, *On* or *Off*.

If you change the setting to *On*, you will be asked to enter a diversion phone number using the digit keys.

Divert Data Calls

This option will enable you to divert all Data calls to a single number.

The option has two settings, *On* or *Off*.

If you change the setting to *On*, you will be asked to enter a diversion phone number using the digit keys.

Cancel All Diverting

This option will enable you to cancel the diversion of incoming calls.

 **This option resets all diversion settings to *Off* and removes all diversion numbers.**

Talk and Fax

This is a network feature that allows you to speak and then send or receive a fax during the course of a single call.

 Your phone supports a data and fax transmission speed of up to 9.6 kbps.

Before making a Talk and Fax call, ensure that:

- Your phone is “fax-ready” (it has been switched off, connected to the fax with one of the optional data/fax accessories, then switched back on). Connecting your phone to the fax in the middle of the call will not work.
- The Talk and Fax mode is set to **On**.

A Talk and Fax call automatically switches to fax mode when you start sending the fax. While the fax is being transmitted, the message **Fax in Progress** will be displayed. The call automatically ends when the fax transmission is complete. You cannot switch back to voice mode in the same call.

 While a Talk and Fax call is active, incoming call services like Call Waiting and Call Holding are suspended.

If you receive a Talk and Fax call when:

- Your phone is not fax-ready – you can only talk.
- Your phone is fax-ready but Talk and Fax mode is off – the call is automatically routed to your fax (you cannot talk).

On

Switches Talk and Fax mode on for the next and all subsequent calls.

Off

Switches Talk and Fax mode off for the next and all subsequent calls.

OK Call Waiting

The Call Waiting menu item has two settings **On** or **Off**. If you select **Off**, you will not be notified of waiting calls. The person trying to contact you will either receive the busy tone, or be diverted by the ‘Detailed Diverting – If Busy’ option.

If Call Waiting is **On**, you will be notified of a waiting call by an audible alert and by the message **Call Waiting – Answer?**. You can press the **OK** key to accept the waiting call, or use the **MENU** and then the  key to scroll to an alternative option and then press **OK**.

 If you have Caller Line Identification, the caller’s number or name is displayed instead of the Call Waiting message.

 Availability of this feature depends on your service provider.

9-16 Handset options menu



OK Call Barring

Call barring is a network feature which can be used to selectively bar outgoing and incoming calls.

If you change the barring setting, you may be asked to enter your barring password. There will be a short delay while the phone notifies the network of the new setting. When the change has been made by the network, the phone will display a confirmation message.

The *initial* password will be supplied to you by your Cellular Service Provider when you subscribe to this service.

 This option may be affected by the Fixed Dialling setting.

Bar Outgoing Calls

After selecting this option, there will be a short delay while the phone asks the network for the current setting.

Int'l Calls

When selected, this option will bar outgoing international calls.

Int'l Calls Except Home

When selected, this option will bar outgoing international calls, except those to your home country.

All Calls

When selected, this option will bar all outgoing calls, except emergency calls.

Off

When selected, this option will disable all call barring for outgoing calls.

Bar Incoming Calls

After selecting this option, there will be a short delay while the phone asks the network for the current setting.

When Roaming

When selected, this option will bar incoming calls when you are roaming. You may wish to select this option, as some Cellular Service Providers charge an additional fee for receiving calls when you are roaming.

All Calls

When selected, this option will bar all incoming calls.

Off

When selected, this option will disable all call barring for incoming calls.

Cancel All Barring

This option can be used to set all Call Barring options to **Off**.

Change Bar Password

This option can be used to change the call barring password.

After selecting this option, you will be asked to enter the current password.

You will then be asked to enter, and then re-enter, your new, **4-digit**, barring password. When the change has been made by the network, the phone will display a confirmation message.

Messages menu

Menu Navigation

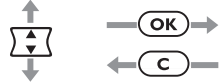

- † Availability depends on the type and settings of the SIM card and/or your subscription to these services.
- ‡ See 'Send Message' option in 'Outgoing Messages' section.

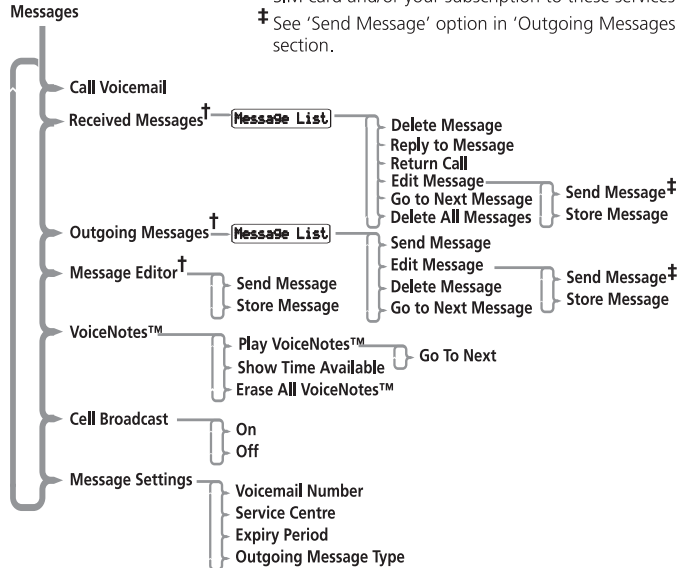



Your phone supports the two GSM message features: Short Message Services (SMS) and Cell Broadcast.

SMS Messages

These are text messages that are sent specifically to and from your phone number.

When an SMS message is received, your phone:

1. Makes three short alert tones (depending on the 'Ring' setting).
2. Displays the  (messages) icon.
3. Stores the message for later viewing, if there is space. If there is not enough space, the  icon will flash. One or more messages must be removed before the message can be stored.

Your Cellular Service Provider will transmit a message for a limited amount of time. If a memory location is not made available before the message is removed from the network, then you will not be able to receive or read it.

4. Message will then be displayed with the prompt; **Read Now?**
5. If **OK** is pressed, the phone will enter the Received Messages browser and immediately display the new message.
6. If **C** is pressed the phone will return to the screen which was displayed prior to receipt of the message.
7. If any other key is pressed it will perform the function linked with that key.
8. If no key is pressed the display will time-out after 1 minute and return to the screen which was displayed prior to receipt of the message.

9-18 Handset options menu



Cell Broadcast Messages

These are general messages, broadcast to a group of phones and can only be received when your phone is in standby mode.

These messages are broadcast in numbered 'channels' and, in general, each channel will tend to carry one particular type of information.

Typical cell broadcast channels could have information on local weather conditions, traffic reports or stock market prices. Please contact your network operator for a list of available channels and the information they supply.

When the message has scrolled across the display, the beginning of the message will be shown until you either remove it or a new message arrives.

How to Read SMS Messages

You can use the scroll key () to scroll through messages in either the Received Messages or Outgoing Messages lists.

To display a specific message, enter the message number, for example press  to display the 5th message. If the message does not exist, Invalid Msg Number will be displayed.

Alternatively, to display the next message, press  and select Go To Next Message.

How to Create and Edit SMS Messages



Use the *Message Editor* to create or modify text messages. When you enter the editor, the last message that was edited will be displayed. Press and hold  to clear the message and start a new one, or modify the message displayed. For an explanation of how to enter text, see **How to enter alphabetic characters** on page 9-4.



Press  once you have completed your message. You will then be presented with the following options:

- **Send Message** – If you select this option you will be prompted for a phone number, enter the number and then press  to send the message.
- **Store Message** – Select this option to store your edited message in your Outgoing Messages list.

 If you don't store the message after it has been edited, you will lose all your changes as soon as you select another message to be edited.



Call Voicemail

 Press  to call the Voicemail number.

This option will make a call to the current voicemail number. You can also press  to call the Voicemail number. Select the Quick Access feature ( Call Voicemail?) or after the tone, say the Voice Tag name. See **Voice Activation for Quick Access Features** on page 8-5.

The voicemail number is entered using the 'Voicemail Number' option in the Message Settings menu.

Received Messages

 Press . Select the Quick Access feature ( Read Messages?) or after the tone, say the Voice Tag name. See **Voice Activation for Quick Access Features** on page 8-5.

This option is used to view and manage any SMS messages that have been sent to your phone number.

When selected, this option will display a message indicating the total number of messages and how many of these are new. If there are no messages **No Messages** will be displayed.

If there are messages, the new messages will be displayed first, followed by the old. Repeated presses of the  key will display the whole message, when it was sent and the phone number who sent it (if available).

Once you have read a new message it will automatically become old.

See **How to Read SMS Messages** on page 9-18 for more information on navigating through the messages.

Press the  key, when viewing any message, to enter the sub-menu.

Delete Message

This option will delete the currently viewed message

Reply to Message

This option allows you to reply with a message.

Return Call

This option can be used to call the person who sent you the message, if their number has been included by the network, or a number that has been included in quotes “” in the message.

Edit Message

This option allows you to use the Message Editor to edit the selected message and then to either send the modified message and/or store it in your Outgoing Messages list. See **How to Create and Edit SMS Messages** on page 9-18 for more information on using the Message Editor.

Go to Next Message

This option will display the next received message.



If you are currently reading the last message in your list then this option will take you back to the top of the list.

Delete All Messages

This option allows you to delete all received messages whether they have been read or not.

 Once deleted, messages are NOT retrievable.

Outgoing Messages

 Press . Select the Quick Access feature ( → Outgoing SMS?) or after the tone, say the Voice Tag name. See **Voice Activation for Quick Access Features** on page 8-5.

This option is used to view and manage any outgoing messages. These messages will be stored on your SIM card. When you select this option, the total number of messages will be displayed followed by the first message in the list.

 You cannot send an outgoing message until the Message Service Centre number has been set. See **Message Settings** on page 9-21.

Press the  key, when viewing any message, to enter the sub-menu. See **How to Read SMS Messages** on page 9-18 for more information on navigating through the messages.

9-20 Handset options menu

Send Message

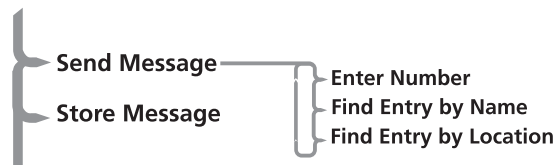

This option allows you to add the destination phone number using a sub-menu. Using the scroll keys you can select:

Enter Number – this allows you to manually enter the phone number using the keypad and send the message.

Find Entry by Name – this allows you to recall a phone number from the Phone Book by name and send the message (see **Find Entry By Name** on page 9-5).

Find Entry by Location – this allows you to recall a phone number from the Phone Book by location and send the message (see **Find Entry By Location** on page 9-6).

Edit Message

This option allows you to use the Message Editor to edit the selected message and then to either send the modified message or store it in your Outgoing Messages list. See **How to Create and Edit SMS Messages** on page 9-18 for more information on using the Message Editor.



Delete Message

This option will delete the currently viewed message.

Go to Next Message

This option will display the next outgoing message.

Message Editor



 Press . Select the Quick Access feature ( Message Editor?) or after the tone, say the Voice Tag name. See **Voice Activation for Quick Access Features** on page 8-5.



The Message Editor is used to edit the currently selected message and then to either send the modified message or store it in your Outgoing Messages list. See **How to Create and Edit SMS Messages** on page 9-18 for more information on using the Message Editor.

VoiceNotes™

The VoiceNotes™ feature allows you to record a number of personal voice messages or to record conversations during a phone call. See **Using VoiceNotes™** on page 8-1 for more information.

Play VoiceNotes™

 Press . Select the Quick Access feature ( Play VoiceNotes™?) or after the tone, say the Voice Tag name. See **Voice Activation for Quick Access Features** on page 8-5.

This option allows you to play your VoiceNotes™. Press  to scroll through the VoiceNotes™. Press  while a VoiceNote™ is playing to go to the next VoiceNote™.

Show Time Available

This option displays the amount of time available for you to record your VoiceNotes™.

Erase All VoiceNotes™

This option allows you to delete all your VoiceNotes™.

Cell Broadcast

This option is used to set the cell broadcast settings. The option has two settings On or Off.

If you change the setting to On, you will be asked to enter the channel you wish to receive information from.

Please contact your Cellular Service Provider for a list of available channels and the information they provide.

While a broadcast message is scrolling across the display you can stop and start it by pressing (*). Press (#) to restart the message from the beginning. If you want to remove the message from the display, press (C).

 If you need to use the (*) and (#) keys for their normal functions while you are receiving a cell broadcast message, you must first remove the message.

Message Settings

VoiceMail Number

This option is used to enter a phone number which will be used by the 'Call Voicemail' option.

If there is already a Voicemail Number, this will be shown in the display. This can be used, modified or deleted as desired.

 Remember to add the + symbol and the appropriate country code prefix to the phone number.

Service Centre

Before you can send any messages you must use this option to enter your Message Service Centre number. This number is obtained from your Cellular Service Provider.

If there is already a Message Service Centre number, this will be shown in the display. This can be used, modified or deleted as desired.

 Remember to add the + symbol and the appropriate country code prefix to the phone number.

Expiry Period

You can use this option to specify the maximum time, in hours, that your unforwarded messages are to remain with the Message Service Centre before being deleted. When you select this option, the current expiry period will be displayed (the default is 24 hours).

The maximum value you can enter is 10584, though the real limit will depend on your Message Service Centre.

Outgoing Message Type

This option is network dependent and can be used to specify the format of your outgoing messages. You can select from the following message types: Text (default), Fax, X400, Paging, E-Mail, ERNIES or Voice.

 You do not need to select Voice to send messages to Voicemail boxes.

9-22 Handset options menu



Phone Setup menu

Menu Navigation



Items shown in *Italics* are available only when **Extended Menus** are switched on.

† Availability depends on the type and settings of the SIM card and/or your subscription to these services.

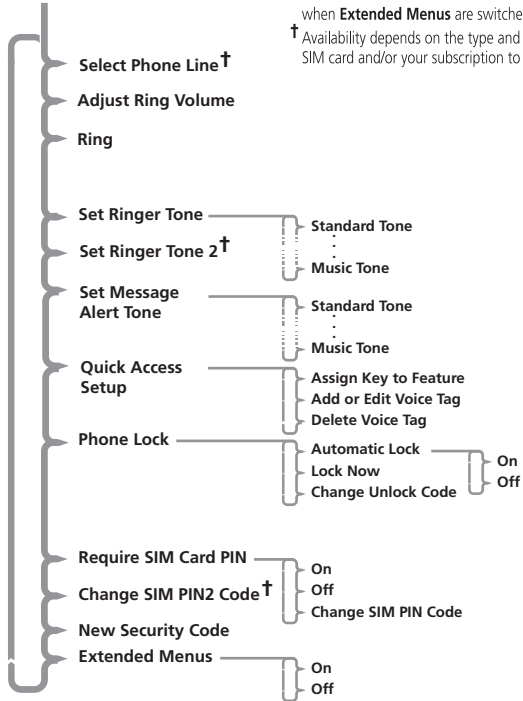

Phone Setup (Extended Menus - Off)

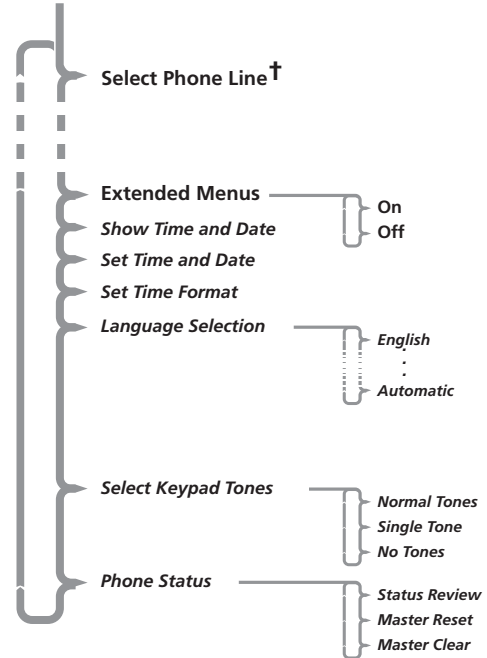

Phone Setup (Extended Menus - On)



Select Phone Line

 Press . Select the Quick Access feature (📞 Switch Line 1/2?) or after the tone, say the Voice Tag name. See **Voice Activation for Quick Access Features** on page 8-5.

This option allows you to switch between Line 1 and Line 2.

 Availability depends on the type and settings of the SIM card, and/or your subscription to this feature.

 This feature is not available when you are using the GSM 900 band.



Adjust Ring Volume

This option is used to set the incoming call ring tone volume.

The volume will be displayed as follows:



Adjust the volume by pressing the volume buttons on the side of your phone.

 Press  followed by the volume button to either increase or decrease the ringer volume.

OK Set Ringer Tone

This option sets the tone your phone will make when an incoming call is received on Line 1.

Standard Tone

Your phone makes a standard ringing tone.

Single Ring Tone ... Music Tone

When selected, your phone will produce one of these alternative ringer tones.

 If you select the Single Ring Tone option, the phone will only ring once when a call is received.

OK Set Ringer Tone 2

This option sets the tone your phone will make when an incoming call is received on Line 2.

 This option will not appear if you do not subscribe to Line 2.

OK Set Message Alert Tone

This option sets the tone your phone makes when it receives an SMS message.

Standard Tone

Your phone makes a standard SMS alert tone.

Single Ring Tone ... Music Tone

When selected, your phone will produce one of these alternative SMS alert tones.

 If you select the Single Ring Tone option, the phone will only ring once when it receives a SMS message.



Quick Access Setup

This option allows you to do the following:

- Customise your Quick Access menu.
- Set up and change the Voice Tag allocation for the Quick Access features.

For more information, see **Voice Activation for Quick Access Features** on page 8-5.

OK Phone Lock

 Press . Select the Quick Access feature ( Lock Now?) or after the tone, say the Voice Tag name. See **Voice Activation for Quick Access Features** on page 8-5.

This option is used to set, and change, the unlock code.

The unlock code can be set to protect your phone from unauthorised use. It can be set to automatically lock your phone each time it is switched on.

The unlock code is a four digit number which is set at manufacture to **1234**. This can be changed at any time by using the 'change unlock code' option.

Automatic Lock

This option can be used to automatically lock your phone each time it is switched on. The option has two settings, **On** or **Off**.

Lock Now



This option can be used to immediately lock your phone. Once selected, your phone will be unusable until the unlock code is entered.

Change Unlock Code

This option is used to change the unlock code.

After selecting this option, you will be asked to enter the current security code before you can proceed.

You can now enter a four digit code to replace the old code.

 By pressing the  key, you can access this option even when the phone is locked.

Require SIM Card PIN

This option is used to set, and change, the PIN code.

The PIN code can be set to protect your SIM card from unauthorised use. If set to **On**, access to your SIM card will be restricted each time it is inserted or the phone is turned on.

The option has two settings, **On** or **Off**.

 If the SIM card does not support PIN code disabling, these items will not appear.

Change SIM PIN Code

This option is used to change the SIM card PIN code.

The 'Require SIM Card PIN' option must be set to **On** and you must enter the old PIN code before you can proceed.

You will be asked to enter a new, four to eight digit code to replace the old PIN code. The new PIN code must be entered again as confirmation.

 **If the PIN number is entered incorrectly three times in a row, your SIM card will automatically lock-up and the Blocked message will be displayed.**

Unblocking Your Phone

If you receive the Blocked message you will need to enter an unblock code and key sequence before you can use the phone.

 The 8-digit PIN unblocking code will have been provided with your SIM card by your Cellular Service Provider.

Enter the following key sequence to unblock your phone:

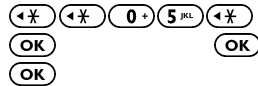

The new PIN code must contain four to eight digits.

 **If this operation is performed incorrectly 10 times in a row, your SIM card will become permanently blocked.**

Change SIM PIN2 Code

This option is used to change your PIN2 security code.

When you select this option you must enter the old PIN2 security code before you can proceed.

You will be asked to enter a new, four to eight digit code to replace the old PIN2 security code. The new PIN2 security code must be entered again as confirmation.

 **If the PIN2 security code is entered incorrectly three times in a row, the Blocked message will be displayed.**

When the Blocked message is displayed, you are not allowed access to menu items that require you to enter the PIN2 code, for example 'Setup Fixed Dialling' and 'Call Charge Settings'.

If you receive the Blocked message when you try to enter your PIN2 code, you will need to unblock and change the code using the following key sequence:

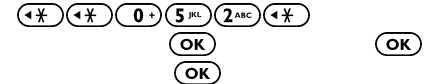

 The 8-digit unblocking code will have been provided with your SIM card by your Cellular Service Provider.

 **If the PIN2 unblocking operation is performed incorrectly 10 times in a row, your PIN2 code will become permanently blocked.**

9-26 Handset options menu



OK New Security Code

The security code is used to control access to security and other options within the menus.



This option is used to change the security code, which is set at manufacture to **000000**.

Once selected, you will be asked to enter the current security code before you can proceed.

You will then be asked to enter a new, six digit code to replace the old security code.

 In order to safeguard your phone, you should change your security code from the factory setting as soon as possible.

OK Extended Menus



 Press and hold . Extended Menus will be temporarily activated until you exit the Options menu.

This option is used to switch the extended menus on or off.

If the extended menu option is switched off, you will not be able to access any of the extended features.

The option has two settings, **On** or **Off**.

Show Time and Date

 Press . Select the Quick Access feature ( Show Time/Date?) or after the tone, say the Voice Tag name. See **Voice Activation for Quick Access Features** on page 8-5.

When selected, this option displays the time and date until any key is pressed.

OK Set Time and Date

This option is used to set the time and date. You will be prompted to **Enter Time** – the time must be entered in 24-hour format. You will then be prompted to **Enter Date**.

OK Set Time Format

This option is used to set the clock to either 12-hour or 24-hour format.

OK Language Selection

This option is used to change the language for display messages.

The option has multiple settings.

When you select a language, all further display prompts and help messages will be in the selected language.

OK Select Keypad Tones

This option allows you to change or disable tones you hear when you press a key.

The option has three settings, **Normal Tones**, **Single Tone** or **No Tones**.

Phone Status

Status Review

This option can be used to view the current setting of menu options.

When selected, your phone will display a list of menu items which have been changed from the default setting. Press the **(MENU)** key to view the next item.

Master Reset

[!] This option should be used with caution.

This option is used to restore certain phone options to their original settings.

When selected, you will be asked to enter the security code. Once entered, the master reset option will perform the following operations:

- Cancel Automatic Answer, Audible Call Timers, In-Call Display Meter, Auxiliary Alert, Automatic Lock, Cell Broadcast and Talk and Fax Mode.
- Return Language Selection to Original.

- Restore Keypad Tones to Normal, Ringer Tones to Standard, SMS Alert Tones to Standard, Volume Level to Medium and Network Search frequency to Medium.
- Restore Extended Menus to their default settings.
- Return the band selection to the default setting.

Master Clear

[!] This option should be used with extreme caution, for example it will clear all the Phone Book entries from your phone memory.

This option is used to restore certain phone options to their original settings.

When selected, you will be asked to enter the security code. Once entered, the master clear option will perform the same operations as 'Master Reset', plus the following operations:

- Clear the Phone Book entries from phone memory (not from SIM memory)
- Clear the Last Calls Made and Last Calls received list

- Clear the Message Editor
- Reset the Resettable Call Timers.
- Erase all recorded VoiceNotes™.
- Erase all recorded Voice Tags.
- Master Clear does **not** clear the:
 - Fixed Dial list
 - My Number(s) list
 - Charge Meters
 - Received and Outgoing Messages list
 - Voicemail number
 - SMS Service Centre number
 - Lifetime timer.

Network Selection menu

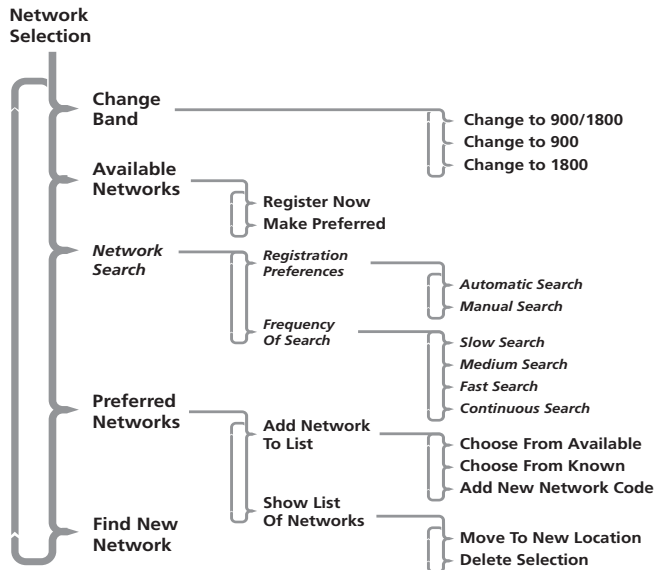

Network Selection

In order for the phone to make and receive phone calls, it must register with one of the available networks. The phone can handle any of the following types of network: GSM 900, GSM 1800 and combined 900/1800 MHz.

Your phone automatically searches for the last network used. If, for any reason, this network is unavailable, your phone will attempt to register with a new network.

When your phone needs to register with a new network, it will generate a sorted list of networks. The network list is sorted in the following order:

- The Home network.
- Networks from a preferred list.
- A random list of other networks found above a certain signal strength.

Any forbidden networks, stored in the SIM card, will not be included in the sorted list.

Menu Navigation



Items shown in *Italics* are available only when **Extended Menus** are switched on.

Change Band

 Press .



Select the Quick Access feature ( Change Band?) or after the tone, say the Voice Tag name. See **Voice Activation for Quick Access Features** on page 8-5.

The country where you purchased your phone determines the default band that it uses. Phones normally default to the GSM 900/1800 band. When you travel abroad, you must remember to change to an appropriate band.

Use this option to change the band of operation for your phone.

The country where you purchased your phone also determines which of the following options are available:

- GSM 900/1800 (referred to as 900/1800)
- GSM 900 (referred to as 900)
- GSM 1800 (referred to as 1800)

When you select Change Band, your phone prompts you to **View Options?**. Press  and then use the  key to scroll through the options. Press  to select the band you require.



When you select a new band, your phone displays the confirmation message **Changed to XXX**, and then automatically searches all the available networks.

Your phone then attempts to register with a preferred network within the selected band.

If you re-select the currently selected band, the confirmation message still appears but the band is not changed and the phone does not attempt to register with any other network.

 You cannot change bands during a call. If you attempt to change bands during a call, your phone displays **Can't Access Network** and then returns to the in-call display.

Available Networks

When selected, this option will scan to see which networks are operating in your current location. When the scan is complete, press the  key to scroll through the list. When you see a network you wish to register with or store in your preferred list, press the  key. You will now enter the 'Register Now' and 'Make Preferred' sub-menu.

Register Now

Once selected, your phone will try to register with the selected network. If the registration fails, your phone will try to register in the normal way.

Make Preferred

Once selected, you will be asked where the selected network is to be located in the preferred list.

Network Search

These options determine how often your phone tries to register with a network and how the attempt is made.

Registration Preferences

This option determines how the phone tries to register with a network.



The option has two settings, Automatic Search or Manual Search.

Automatic Search Mode

In the automatic mode, the phone will try to register with the first network in the sorted list. If this is successful, your phone will display the network name and then enter the standby mode.

If registration is unsuccessful with one network in the list, your phone will try the next listed network. If your phone fails to register with any of the listed networks, it will start at the beginning of the list after a preset period. The preset period is determined by the 'Frequency Of Search' option.

Manual Search Mode

In the manual mode, the phone will present you with the sorted list of networks. Use the  and  keys to select one network from the list. Your phone will try to register with the selected network. If this is successful, the phone will display the network name and then enter the standby mode.

If registration is unsuccessful, your phone will present the list again after a preset period. The preset period is determined by the 'Frequency Of Search' option.

Frequency of Search



This option is used to determine how long your phone waits before attempting to re-register after a registration attempt has failed.



The option has the following settings: Slow Search, Medium Search, Fast Search or Continuous Search.

Preferred Networks

Add Network to List

This option enables you to add networks to your preferred list.

When selected, the 'Choose From Available' option will scan to see which networks are operating in your current location. When the scan is complete, press the  key to scroll through the list. When you see a network you wish to store in your preferred list, press the  key. You will be asked where the selected network is to be located in the preferred list.

The 'Choose From Known' option will, when selected, present you with a preset list of networks. Press the  key to scroll through the list. When you see a network you wish to store in your preferred list, press the  key. You will be asked where the selected network is to be located in the preferred list.

Select the 'Add New Network Code' option to enter network codes directly. Once entered, you will be asked where the network is to be located in the preferred list.

Show List of Networks

This option is used to display the networks you have stored in your preferred list. In addition, pressing the **OK** key will select the currently displayed entry and enter a move/delete sub-menu.

When 'Move to New Location' is selected you will be asked to enter a new location for the selected network.

When selected, 'Delete Selection' will remove the selected network from the preferred list.

Find New Network



Press **↑**. Select the Quick Access feature (**Find New Network?**) or after the tone, say the Voice Tag name. See **Voice Activation for Quick Access Features** on page 8-5.

When selected, the phone will try to register with a network in the normal manner, with one exception. When the registration attempt is made, your current network will be excluded from the list of those available. If the attempt fails, your phone will then try to re-register with the previous network.

Call Meters menu

Call Meters

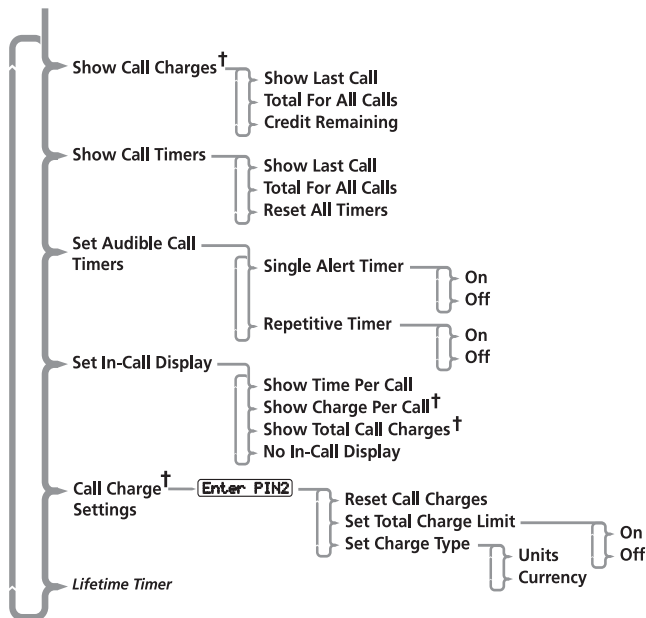

Menu Navigation



Items shown in *Italics* are available only when **Extended Menus** are switched on.

† Availability depends on the type and settings of the SIM card and/or your subscription to these services.

Call Metering

Your phone has an internal metering system which can be used to provide you with individual and total call times or costs.

Call cost information is only available if you receive the Advice of Charge service. If you do not receive this service, then only time meters are available.

The meter can be displayed during a phone call and audible tones can be generated to indicate the passage of call time.

Your phone can handle values up to 21 digits long, although during calls it can only display the last 12 digits. If the value exceeds 21 digits, then *Too Large* is displayed.



In addition, you can set a maximum charge limit so that your phone will monitor either the number of units used or the call cost, and then not allow the limit to be exceeded.

Show Call Charges

This feature allows you to display the cost of your calls or the amount of credit remaining. The figures are in phone units or currency depending on the setting of the *Set Charge Type* option.

Show Call Charges is only available if you receive the Advice of Charge service.

Show Last Call



 Press . Select the Quick Access feature ( Call Charge?) or after the tone, say the Voice Tag name. See **Voice Activation for Quick Access Features** on page 8-5.

Displays the cost of your last chargeable call.

Total For All Calls

Displays the cost of all your chargeable calls since the charge meters were reset to zero using the 'Reset Call Charges' option.

Credit Remaining

 Press . Select the Quick Access feature ( Show Credit?) or after the tone, say the Voice Tag name. See **Voice Activation for Quick Access Features** on page 8-5.



Displays the difference between your total call costs and the limit specified by the 'Set Total Charge Limit' option. If there is no limit, **No Charge Limit Set** will be displayed.

Show Call Timers

This feature allows you to display the duration of your calls and to reset your time meters to zero.

If you receive the Advice of Charge service then all calls are timed. If you do not receive the Advice of Charge service then, depending on the model, either all calls or only outgoing calls are timed.

Show Last Call

 Press . Select the Quick Access feature ( Call Timer?) or after the tone, say the Voice Tag name. See **Voice Activation for Quick Access Features** on page 8-5.

Displays the duration of your last call.

Total For All Calls

Displays the duration of all your calls since the time meter was reset to zero using the 'Reset All Timers' option.

Reset All Timers

Sets the resettable time meters to zero. The Lifetime Meter is not resettable.

Set Audible Call Timers

Your phone provides two programmable audible call timers:

- The 'Single Alert Timer' will sound a beep just once during a call, after a preset time has elapsed.
- The 'Repetitive Timer' will sound regular beeps during a call, at preset intervals.

In both cases, the timers will sound their beeps ten seconds before the end of the programmed time.

Set In-Call Display

This feature allows you to specify whether the time or charge meters are displayed during a call. If you do not have the Advice of Charge service, then only the time meter is available.

 If a total charge limit has been set, then the in-call display always shows your remaining credit.

Show Time Per Call

This option is used to display the time meter during calls. If you receive the Advice of Charge service, only the chargeable calls will be displayed.

Show Charge Per Call, Show Total Call Charges

 These menu items are only available if you receive the Advice of Charge service.

These options are used to display the call charges meter during and after chargeable calls. The meter shows phone units or currency depending on the setting of the 'Set Charge Type' option.

No In-Call Display

This option switches off in-call display of the charge/time meter.

Call Charge Settings

This feature allows you to customise your Advice of Charge settings. You will be prompted to enter your PIN2 security code before you can access the options.

 This menu item is only available if you receive the Advice of Charge service.

Reset Call Charges

This option resets your charge meters to zero.

Set Total Charge Limit

This option sets the maximum limit for call charges; once this limit has been reached, the network will refuse any further chargeable calls.

If you switch the charge limit **On**, you will be prompted to enter a new limit. Enter the amount as either units or currency depending on the setting of the **Set Charge Type** option. Units must be entered as whole numbers.

 When the charge limit is **On**, you will not be able to make fax or data calls.

Once a limit is set, the in-call display will show the remaining credit. When you reach your last two minutes, the warning message **Approaching Charge Limit** will be displayed and a warning alert will sound. The sound will be repeated when one minute remains. When the limit is reached the message **Charge Limit Reached** will be displayed and you will not be able to make any more chargeable calls.

Once the limit is reached the Total Charge Limit will need to be reset or switched off before any chargeable calls can be made.

Select **Off** to switch off the charge limit.

Set Charge Type

This option defines whether charge information is displayed as either phone units or currency.

Units

Sets the charge type to phone units.

Currency

Sets the charge type to currency. You will be prompted to enter the **Currency Name**. Enter a 3-character notation, for example **GBP** for the UK, **DEM** for Germany or **FFR** for France. You will then be prompted for the **Charge Per Unit**. Enter the amount and press **OK**.

Lifetime Timer

This option is used to display the total time of all calls made on your phone.

This meter can not be reset, the **Reset All Timers**, **Master Reset** or **Master Clear** options have no effect.