

## Parking Brake Front Cable 70.35.14

Removal  **CAUTION:**  
Replacement of nuts and bolts: Various thread-locking devices are used on nuts and bolts throughout the vehicle. These devices restrict the number of times a nut or bolt can be used. See section <<100-00>> for information.

1. Position vehicle on a four-post lift.
2. Remove driver's seat. Refer to operation 76.70.01.90.
3. Remove parking-brake lever trim. Refer to operation <<76.13.63>>.

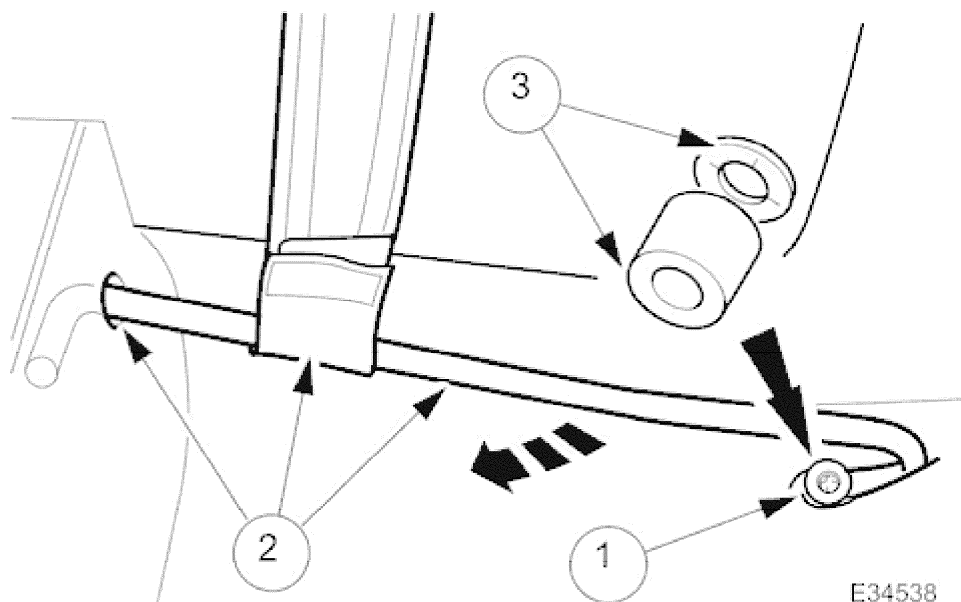

4. Remove the lower slider bar of the driver side seat belt.
  1. Remove bolt.
  2. Remove slider bar from body grommet and seat belt loop.
  3. Collect spacer and card washer.

## 2001 XK RANGE - Parking Brake and Actuation - 206-05

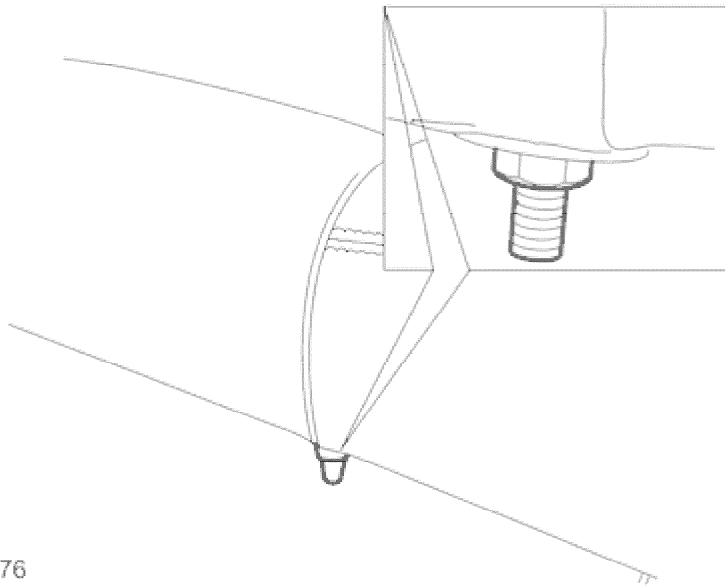

E36076

5. Raise rear seat cushion on driver's side of vehicle for access to carpet.
  - Remove nuts securing seat cushion to body
  - Raise seat cushion.
6. Reposition carpet to gain access to parking brake cable.
7. Raise vehicle.

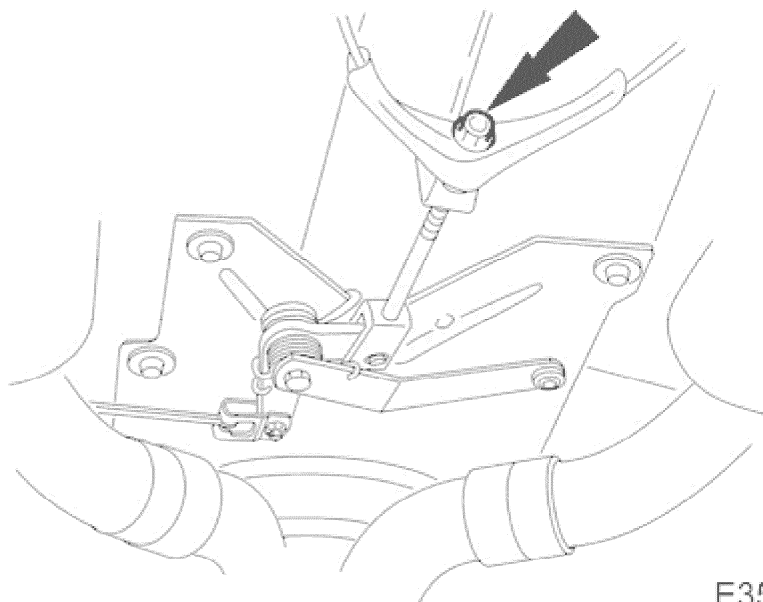

E35206

8. Loosen parking brake cable, adjustment nut.

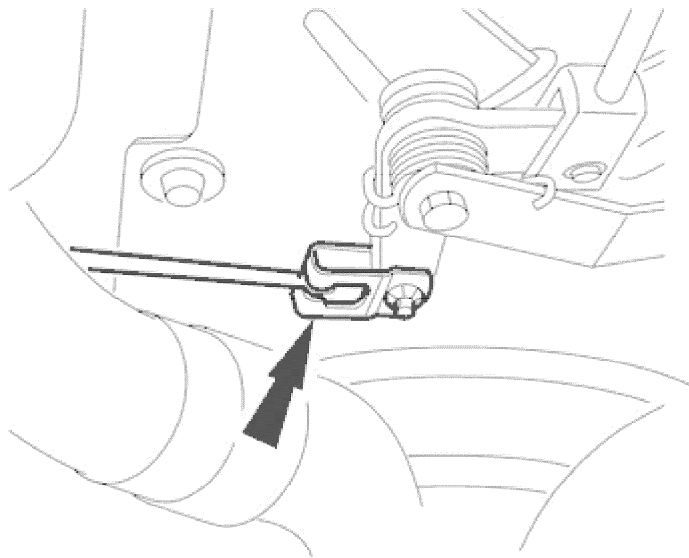

E35224

9. Release parking brake cable from relay-lever fork.

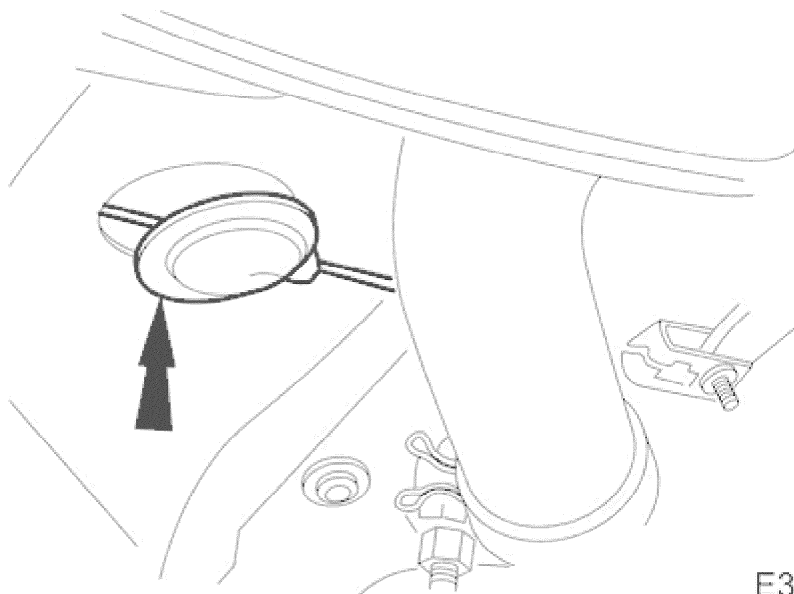

E35217

10. Remove body grommet from cable.

- Remove grommet from body.
- Remove grommet from cable.

11. Lower vehicle.

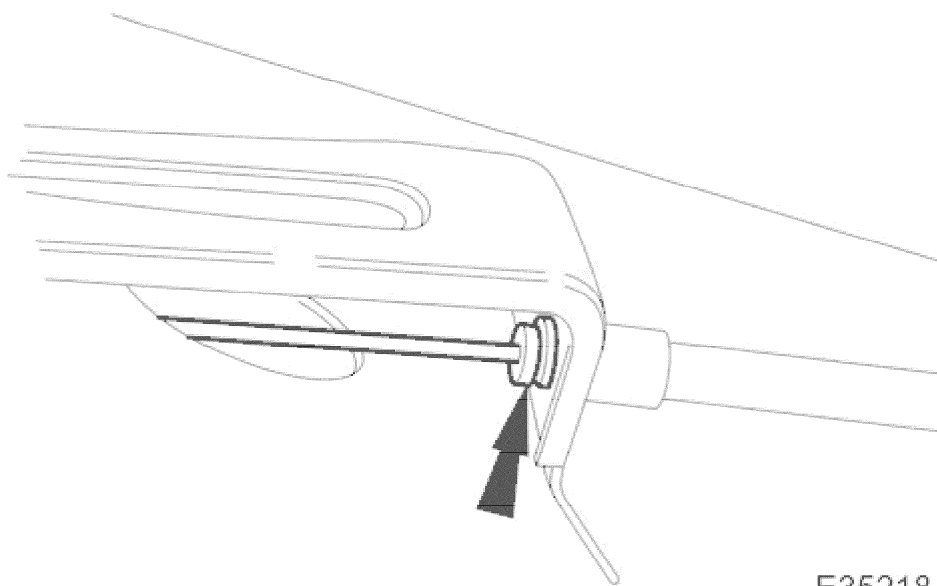

E35218

12. Release cable from abutment bracket.

- Remove retaining clip.
- Pull cable into vehicle.

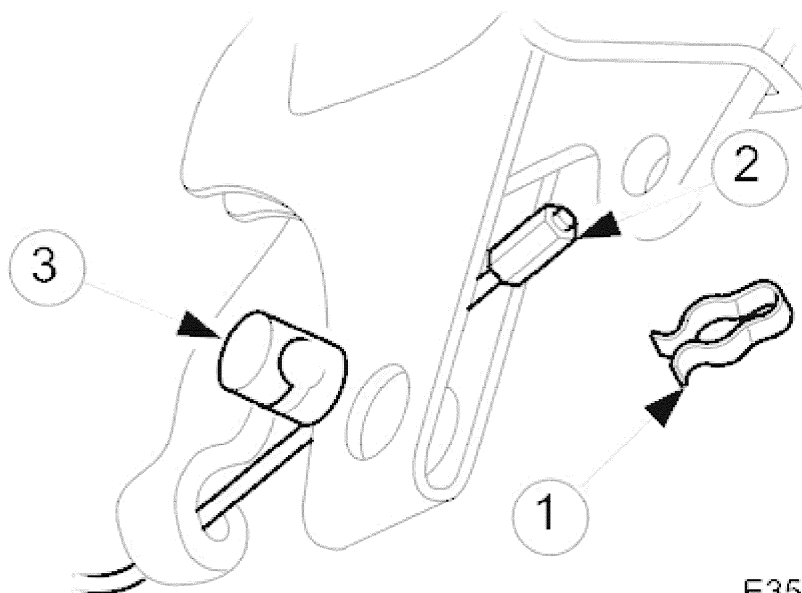

E35219

13. Release brake cable from hand lever.

1. Remove spring clip.
  2. Release cable from trunnion.
  3. Remove trunnion.
- Release cable.

14. Clean components and mating surfaces.

### Installation

1. Lay cable in vehicle in its installed position.

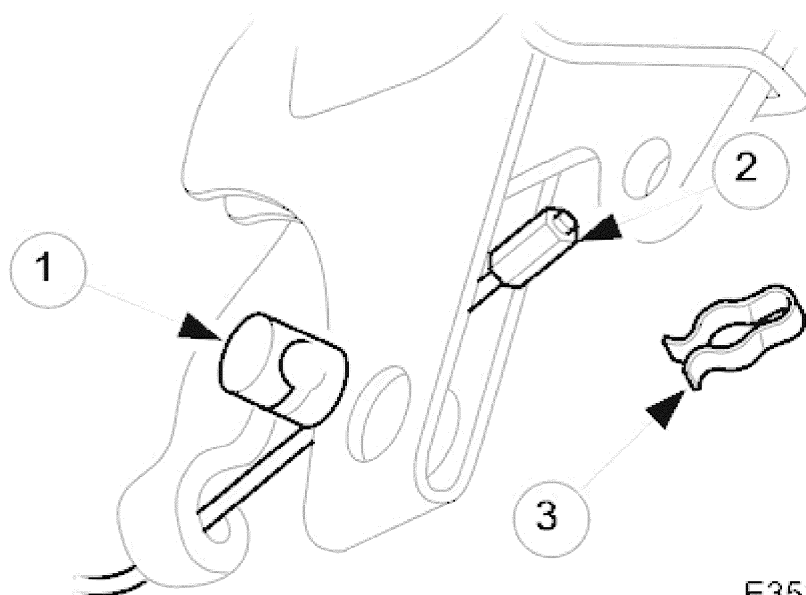

E35232

2. Install brake cable to hand lever.
  - Position cable into hand lever.
1. Install trunnion into hand lever.
2. Install cable into trunnion.
3. Install spring clip.

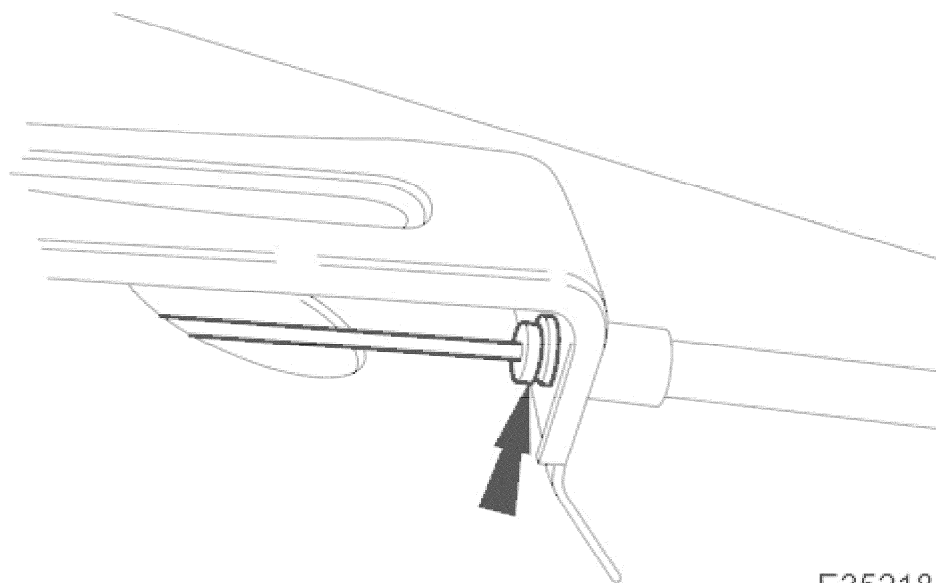

E35218

3. Install cable into abutment bracket.
  - Install retaining clip.

4. Raise vehicle.

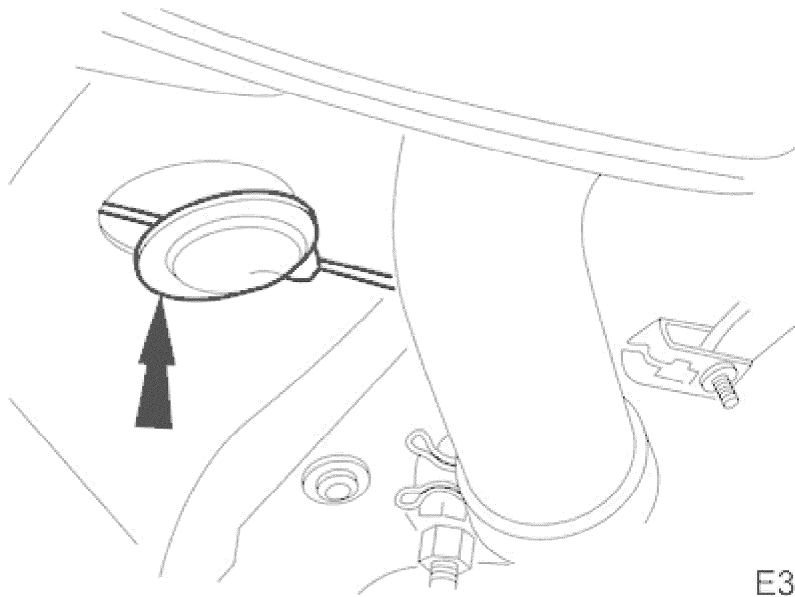

E35217

5. Install body grommet.
- Install grommet to cable.
  - Install grommet to body.

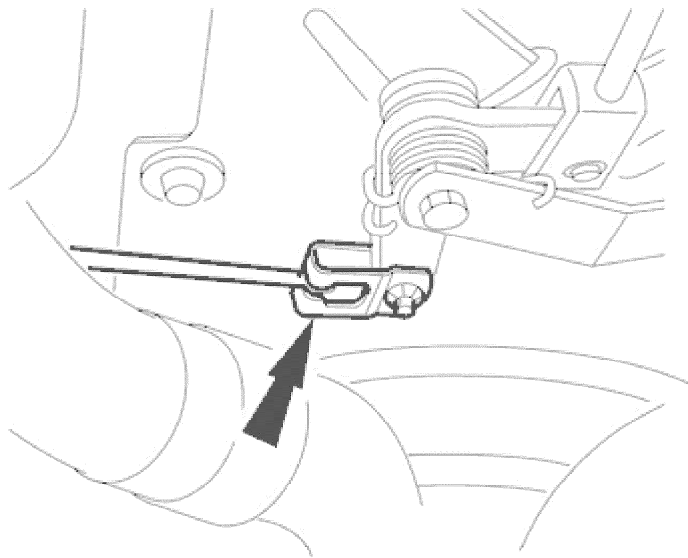

E35224

6. Connect cable to relay-lever fork.
7. Set parking brake. Refer to operation <<70.35.37>>.
8. Lower vehicle.
9. Reposition carpet under rear seat cushion.

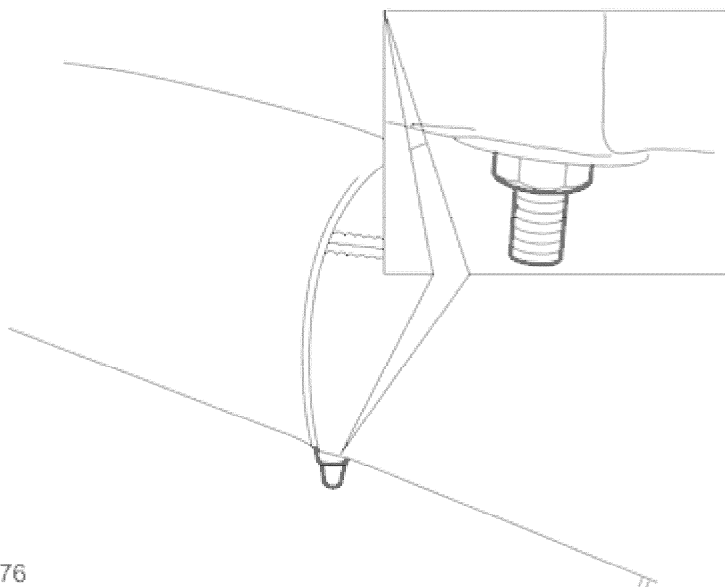

E36076

10. Reposition rear seat cushion.
  - Install nuts and tighten to 5-7 Nm.

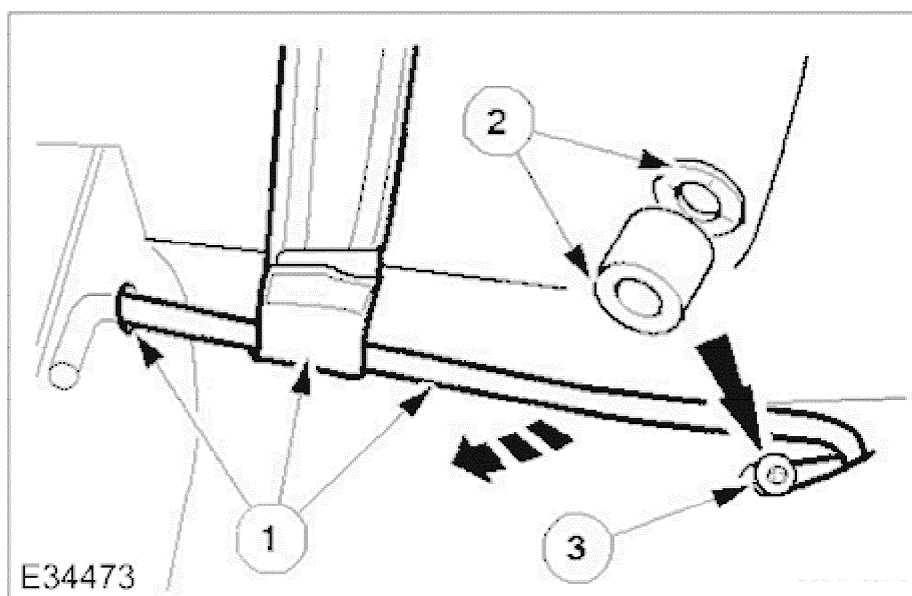

E34473

11. Install the lower slider bar of the driver side seat belt.
  1. Insert slider bar through seat belt loop and body grommet.
  2. Position spacer and card washer.
  3. Install bolt and tighten to 34-46 Nm.
12. Install parking brake lever trim. Refer to operation <<76.13.63>>.
13. Install driver seat. Refer to operation 76.70.01.90.