

Camshaft Cover Gasket - Bank 2

Removal

1. Open the engine compartment and fit paintwork protection sheets.
2. Carefully remove the left hand engine cover, taking care not to damage the plastic fixings or the rubber inserts.
3. Remove the on-plug ignition coils from Bank 2.
4. Remove the purge valve, from the evaporative control system.

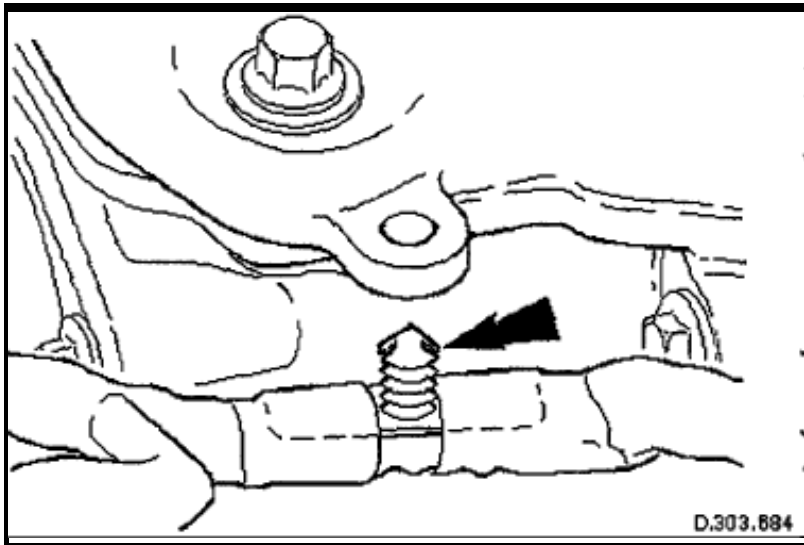

5. Release the clips which secure the engine harness to the cam cover.

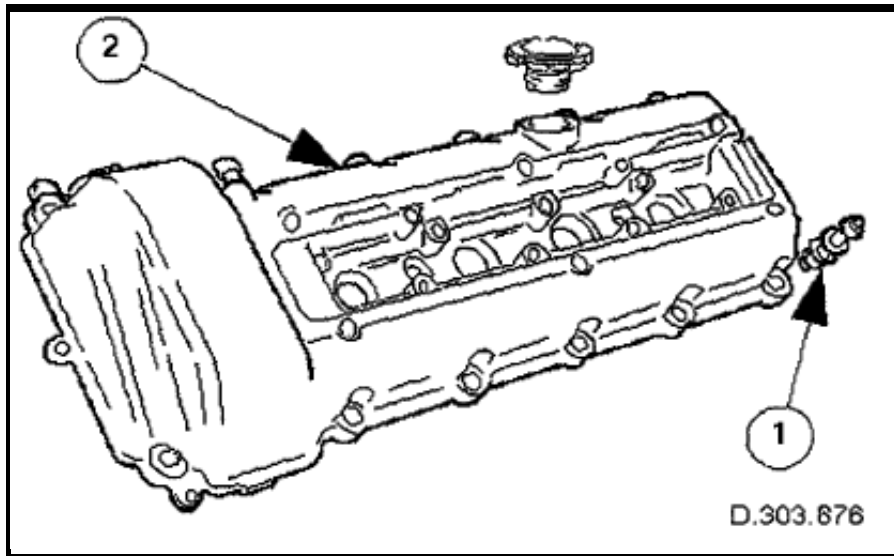

6. Remove the cam cover assembly. Release the fourteen screws which secure the cam cover. The screws stay in place, held by the seals.

Remove the cam cover, screws and seals, as an assembly.

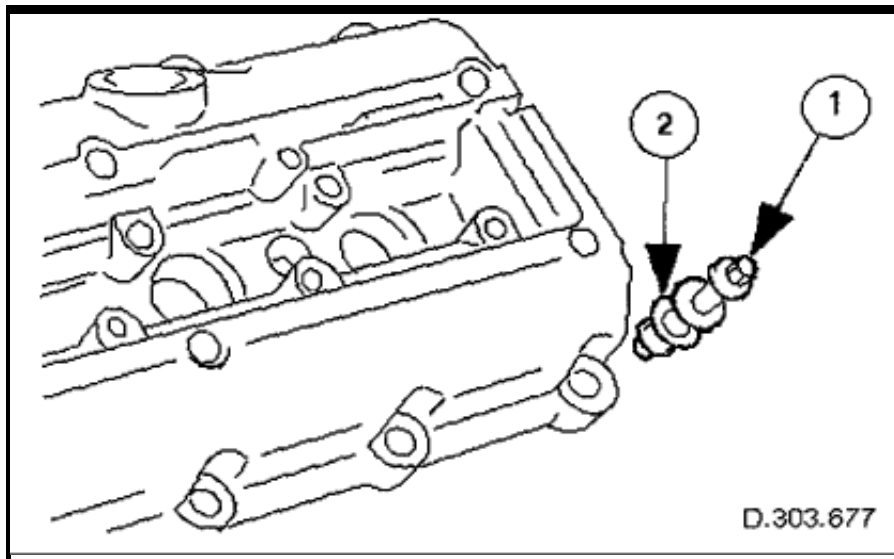

7. Separate the screws and seals from the cam cover. One at a time, remove each securing screw from the cam cover.

Remove the rubber sealing ring from each securing screw.

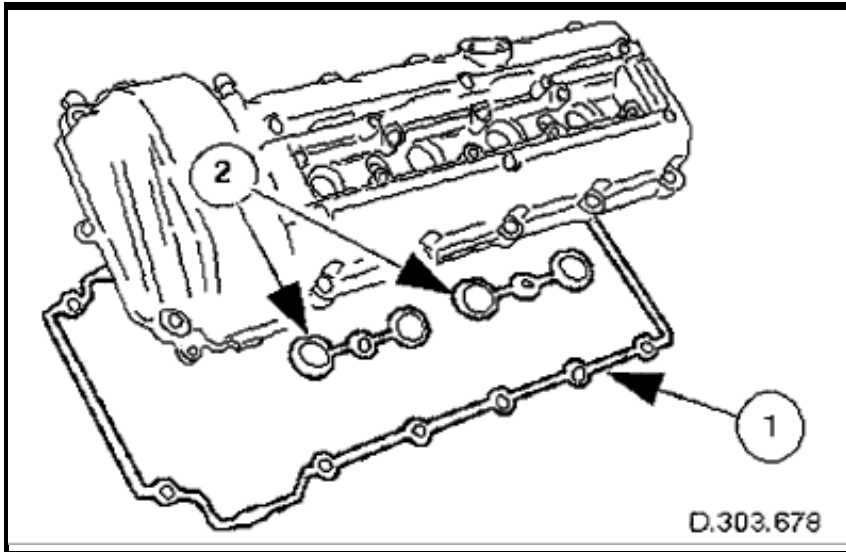

8. Remove the main seals from the cam cover. Remove and discard the outer seal.

Remove and discard the two seals from around the spark plug apertures.

9. Clean all relevant parts and mating faces.

Installation

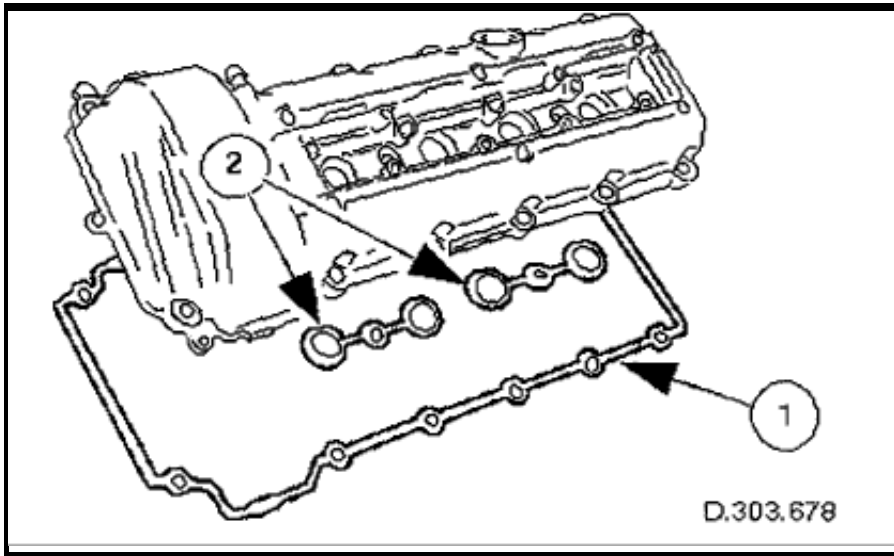

1. Install the new main seals to the cam cover. Install the new outer seal.
Install the two new [spark plug](#) aperture seals.

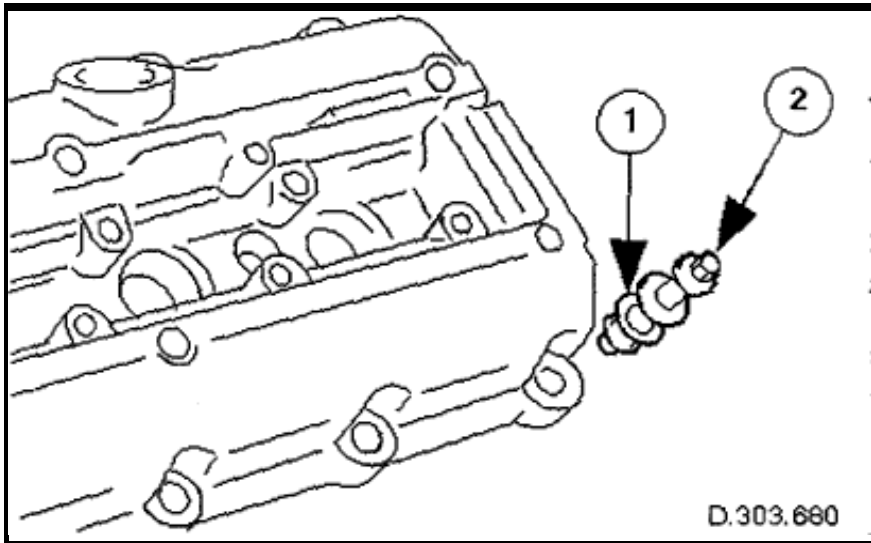

2. Install the securing screws to the cam covers. Install a new sealing ring to each screw assembly.

Install the screws to the cam covers. Each screw is retained by the cam cover gasket.

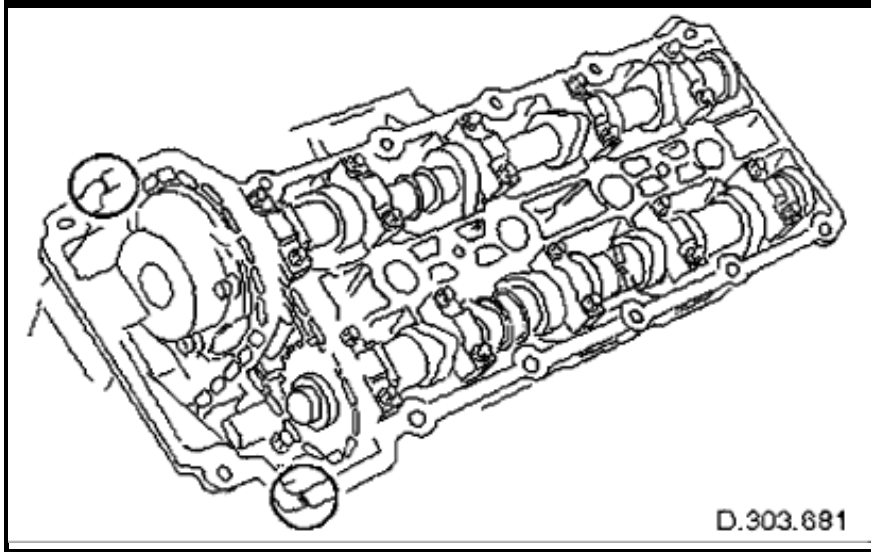

3. Apply sealant to two places on the joint between the front of the cam cover and the cylinder head. The application of sealant must be **3 mm** diameter by **12 mm** long. Install the cam cover immediately after applying the sealant.

The cover should be installed directly to the head without smearing the sealant or the seals.

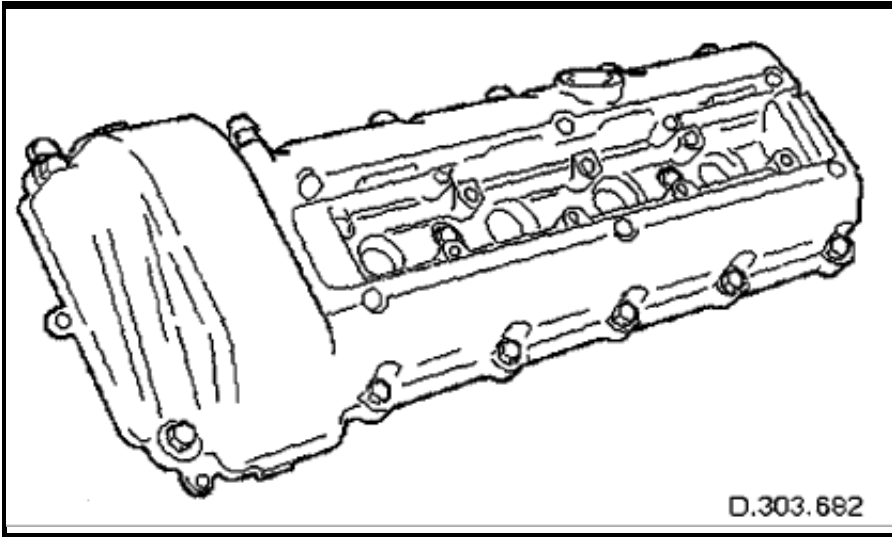

4. Install the cam cover. Position the cam cover onto the cylinder head without smearing the sealant and start the threads of each securing screw.

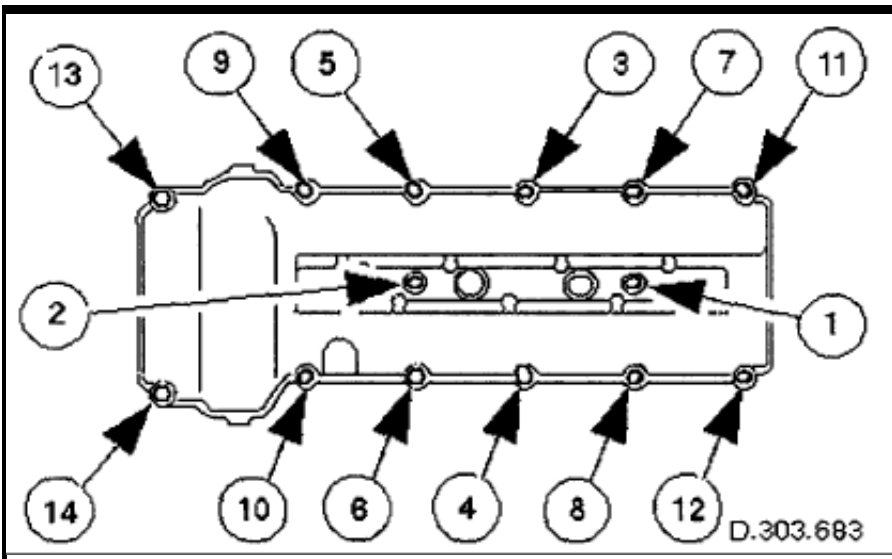

5. Tighten the securing screws to **9 - 11 Nm** . Tighten in the sequence indicated.

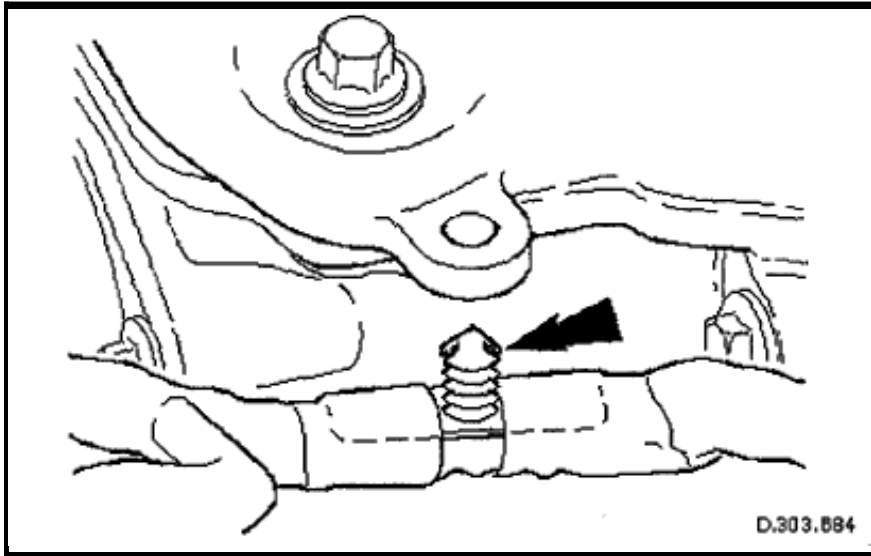

6. Reposition the clips which secure the engine harness to the cam cover.
7. Install the on-plug ignition coils and the coil cover.
8. Install the purge valve.
9. Install the left hand engine cover.
10. Remove the paintwork protection sheets and close the engine compartment.