

1999 XK RANGE - Engine - 303-01

Valve Cover LH 12.29.43

Removal

Vehicles without supercharger

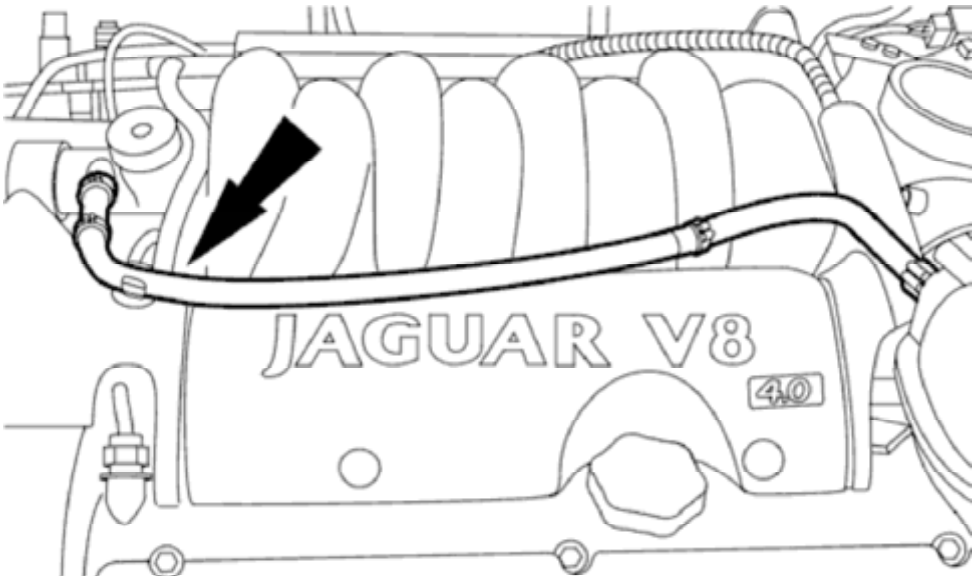

E37492

1. Detach the coolant hose.

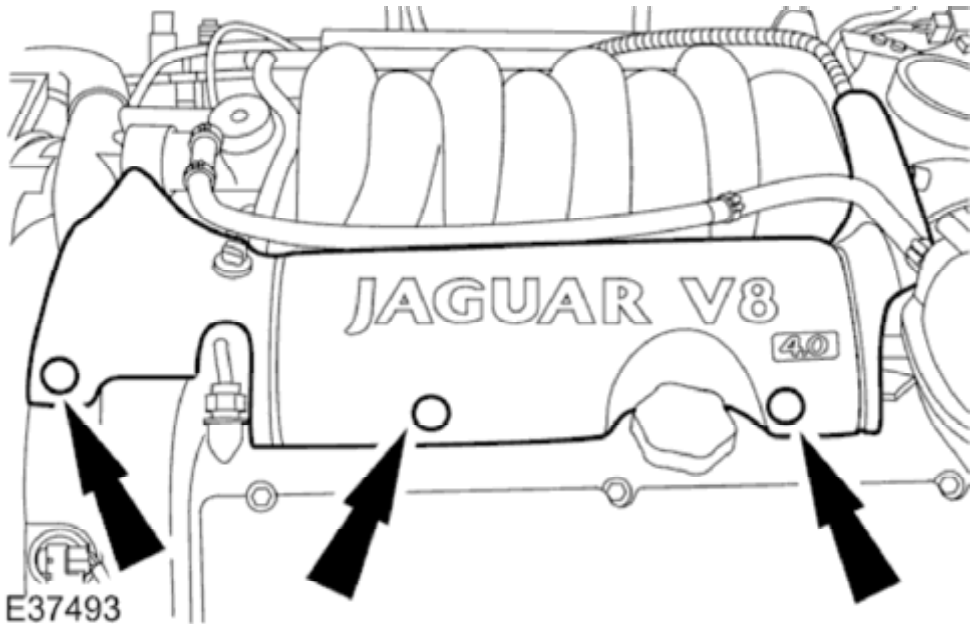

E37493

2. Remove the engine left-hand cover.

1999 XK RANGE - Engine - 303-01

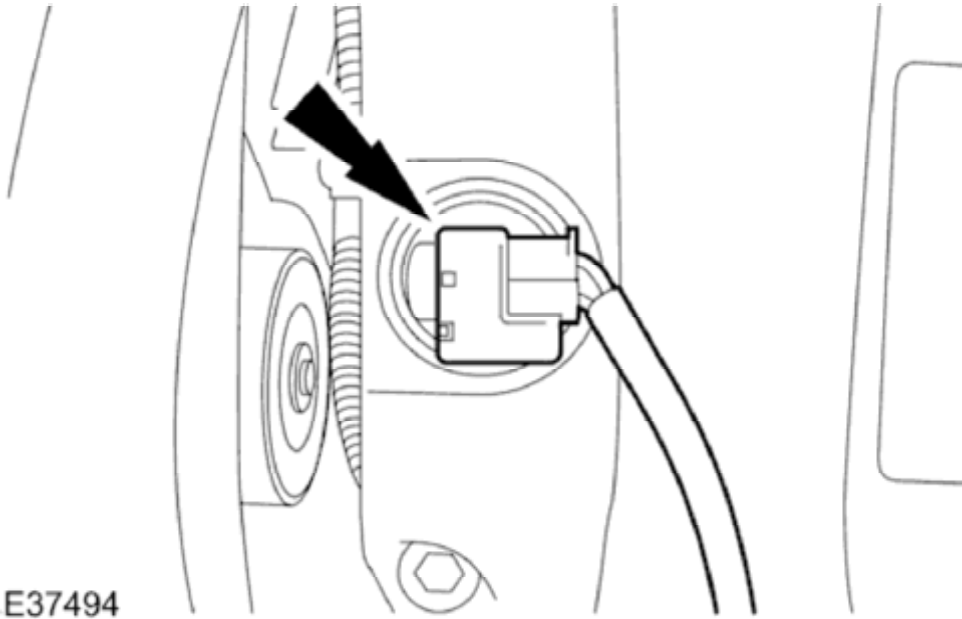

3. Disconnect the variable camshaft timing oil control solenoid electrical connector.

All vehicles

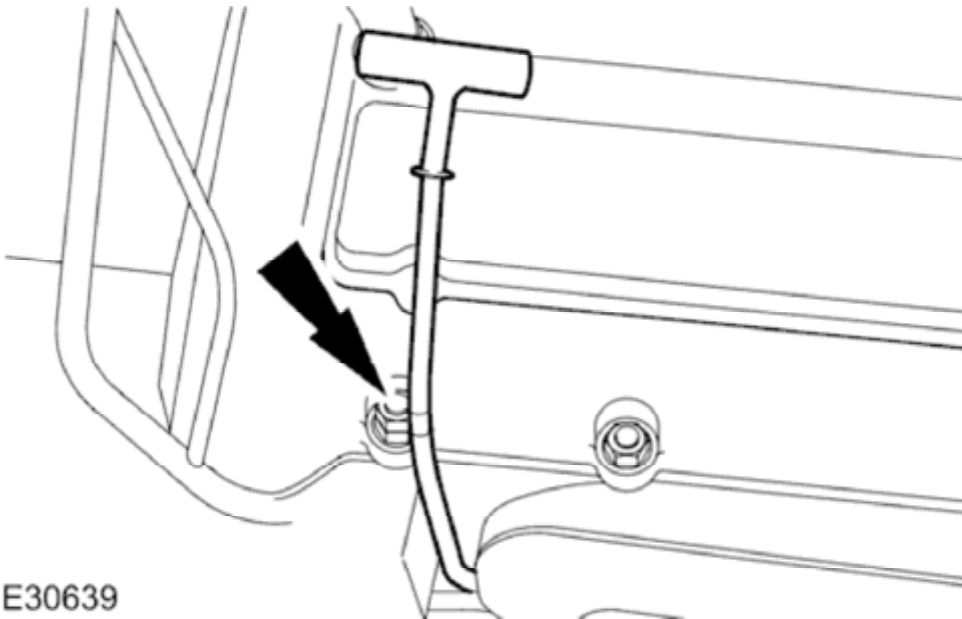

4. Remove the oil level indicator tube.
• Remove and discard the O-ring seal.

5. Remove the left-hand ignition coil-on-plugs.<<303-07>>

1999 XK RANGE - Engine - 303-01

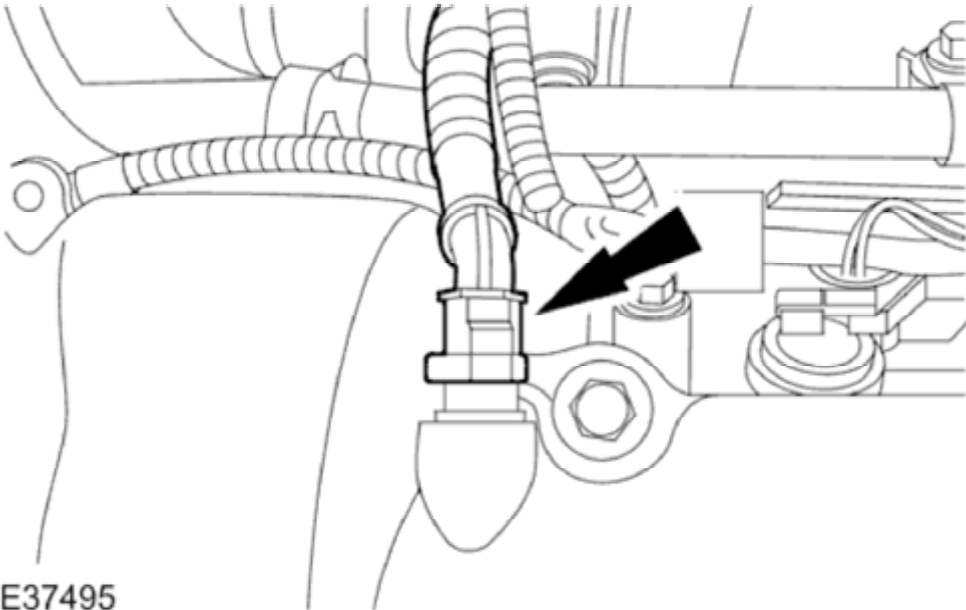

E37495

6. Disconnect the breather hose from the left-hand valve cover.

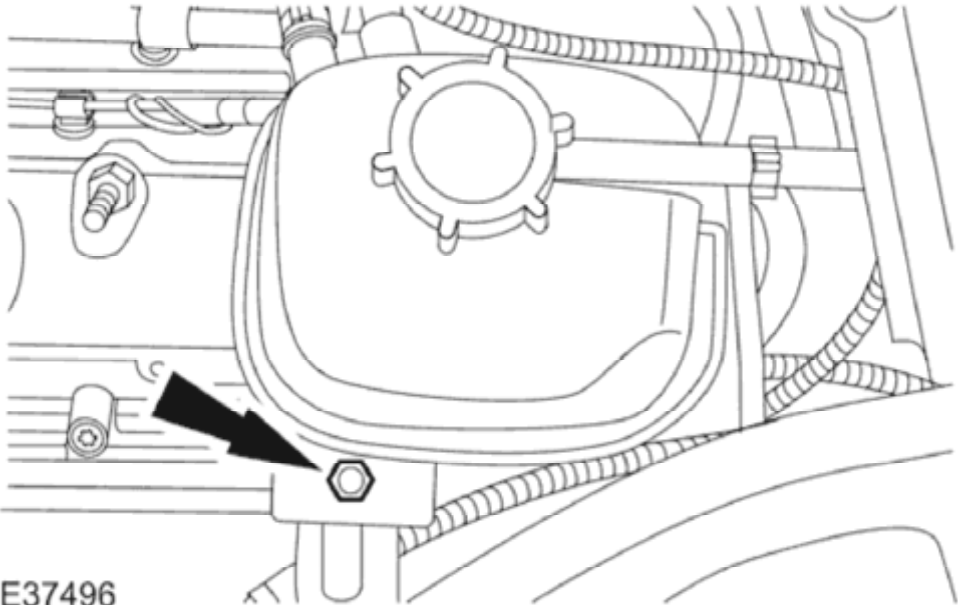

E37496

7. Remove the coolant expansion tank retaining bolt.

1999 XK RANGE - Engine - 303-01

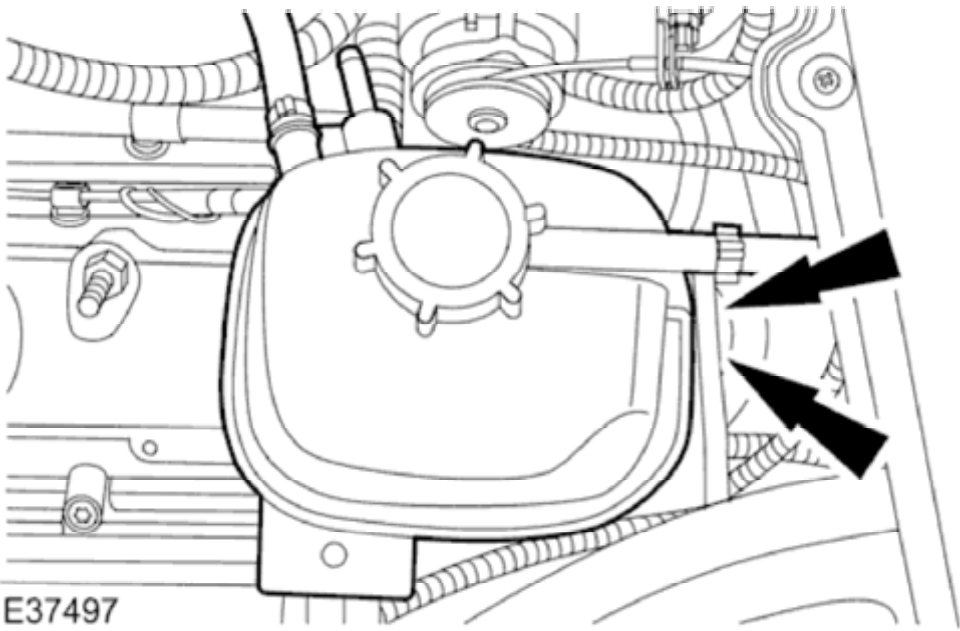

E37497

8. Detach the coolant expansion tank.

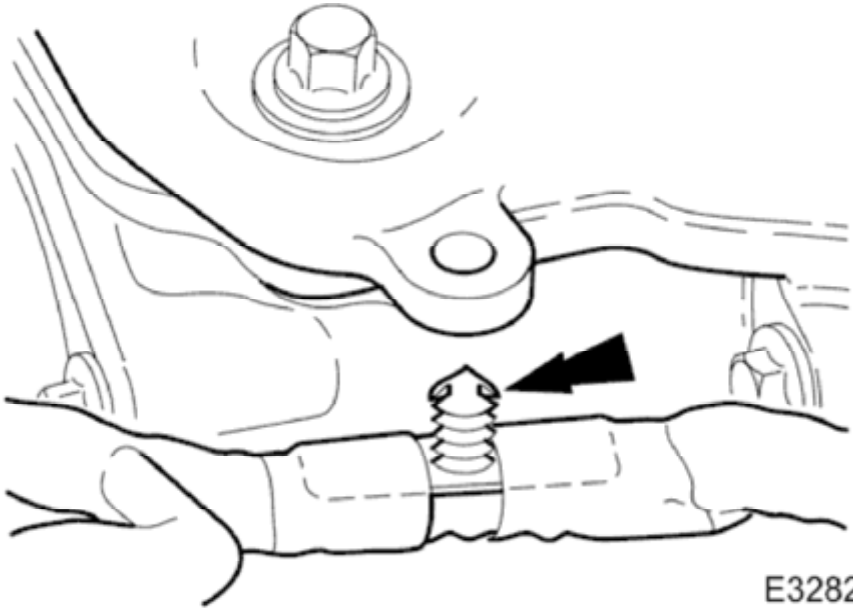

E32829

9. Release the clips which secure the engine harness to the cam cover.

Vehicles with supercharger

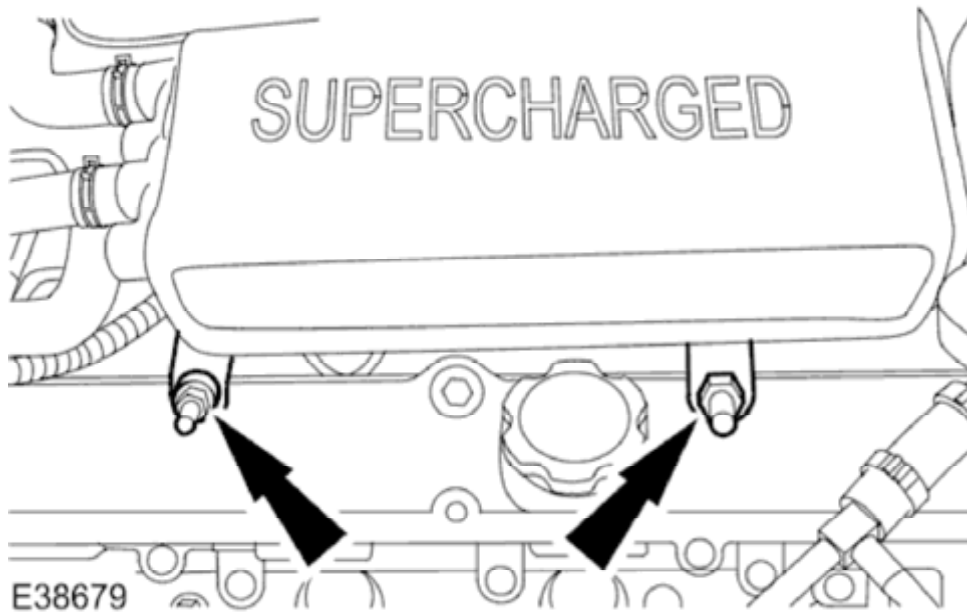

10. Detach the fuel injection supply manifold wiring harness retaining bracket.

All vehicles

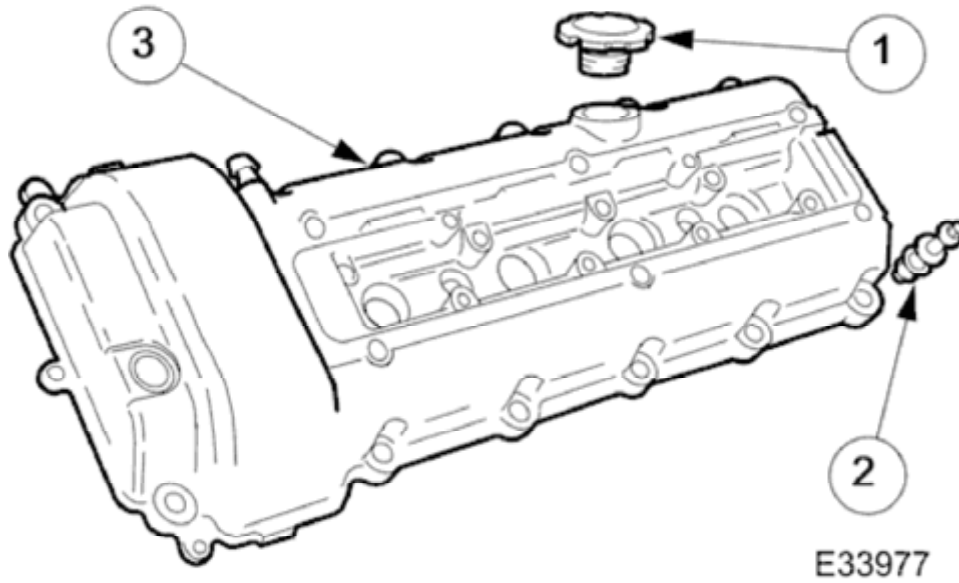

11. Remove the cam cover assembly.
1. Remove the oil filler cap.
2. Remove the valve cover retaining bolts.
3. Remove the cam cover.

1999 XK RANGE - Engine - 303-01

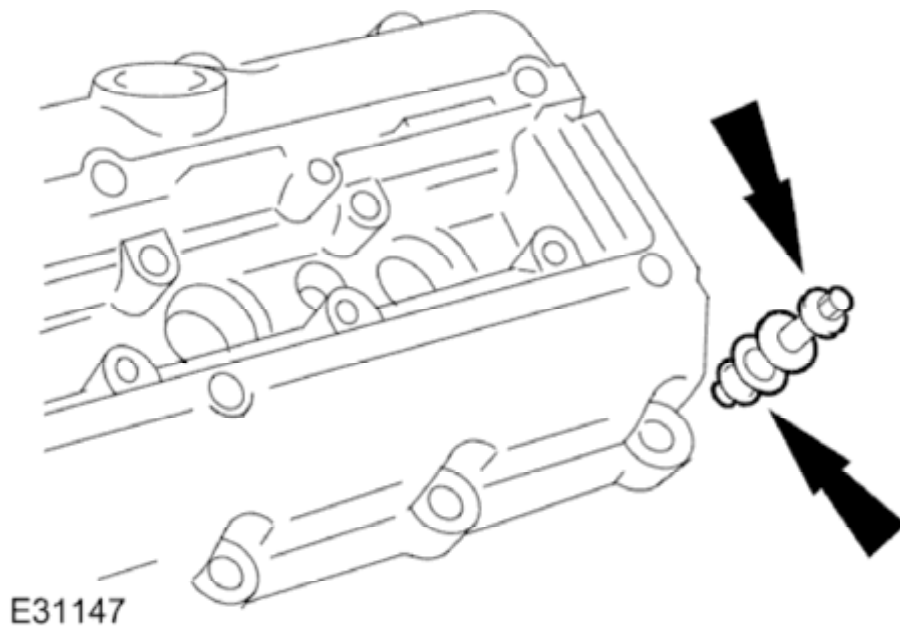

12. **NOTE:**

On removal of the valve cover retaining bolts note their positions in the valve cover.

Remove the valve cover retaining bolts.

- Remove and discard the valve cover retaining bolt O-ring seals.

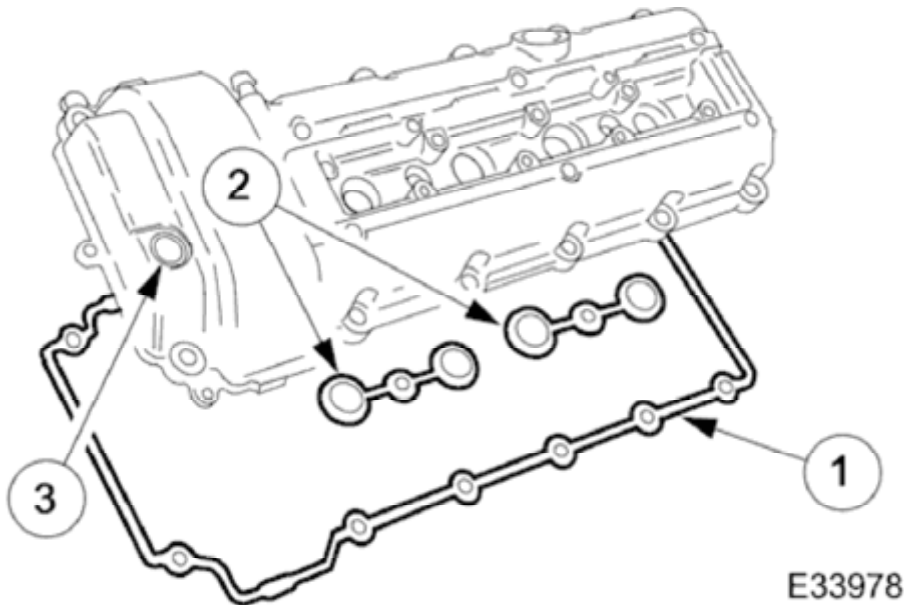

13. Remove the main seals from the cam cover.

1. Remove and discard the outer seal.
2. Remove and discard the spark plug apertures seals.
3. Remove the variable camshaft timing oil control solenoid seal.

14. Clean all relevant parts and mating faces.

Installation

All vehicles

1999 XK RANGE - Engine - 303-01

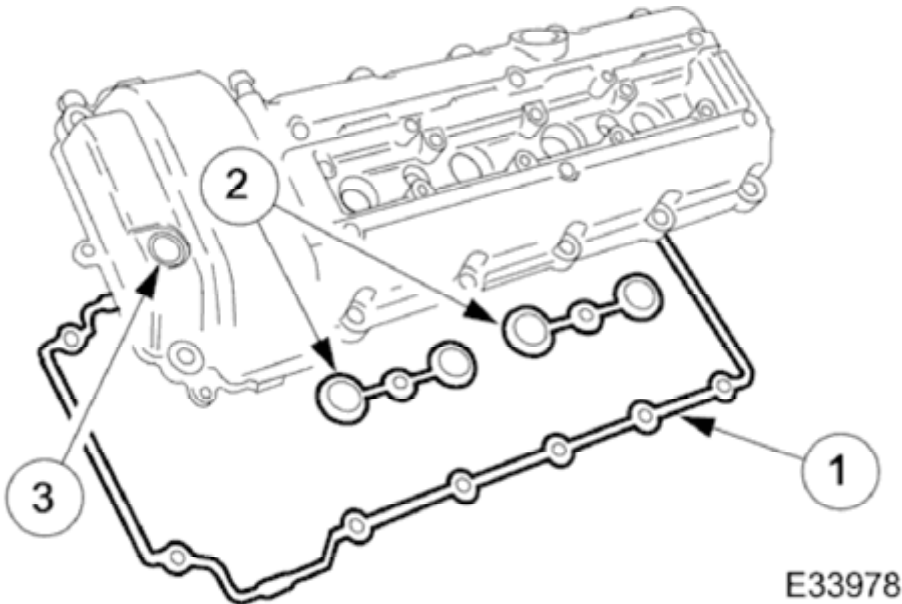

- 1. Install new valve cover seals.
 - 1. Install a new outer seal.
 - 2. Install two new spark plug aperture seals.
 - 3. Install a new variable camshaft timing oil control solenoid seal.

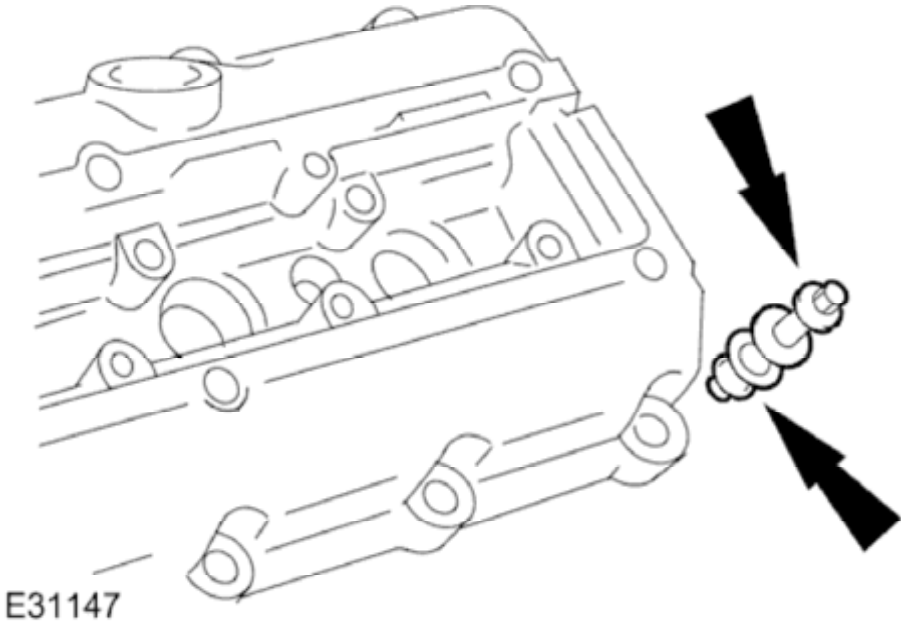

- 2. Install the valve cover retaining bolts to their positions previously noted.
 - 1. Install the valve cover retaining bolts.
 - Install new valve cover retaining bolt O-ring seals.

1999 XK RANGE - Engine - 303-01

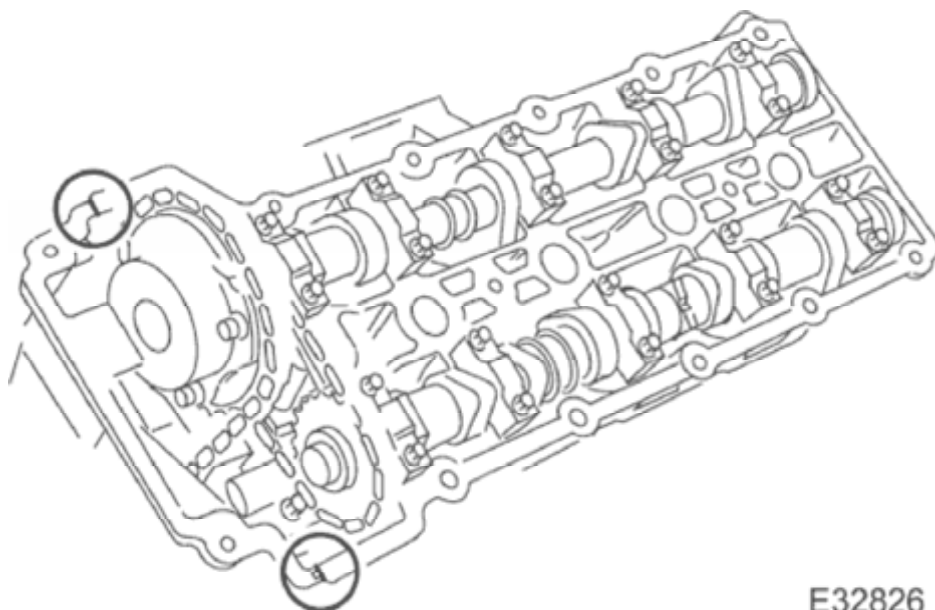

E32826

3. Apply bead of silicone gasket sealant or equivalent meeting Jaguar specification on the two places where the cylinder head and front cover join.

- The application of sealant must be 3mm diameter by 12mm long. Install the cam cover immediately after applying the sealant.
- The cover should be installed directly to the head without smearing the sealant.

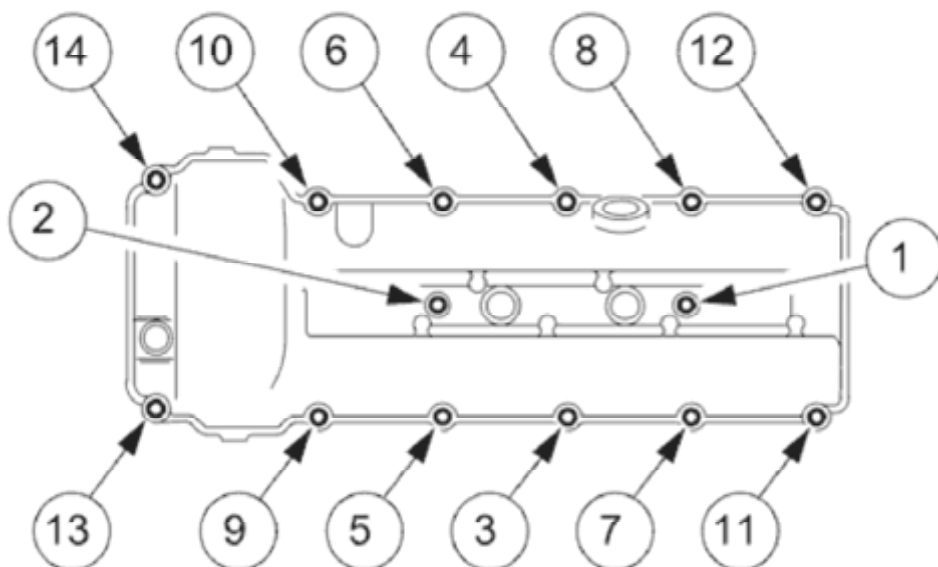

VUJ0001977

4. Install the valve cover.

- Complete the tightening sequence.
- Tighten to 11 Nm.

5. Install the oil filler cap.

Vehicles with supercharger

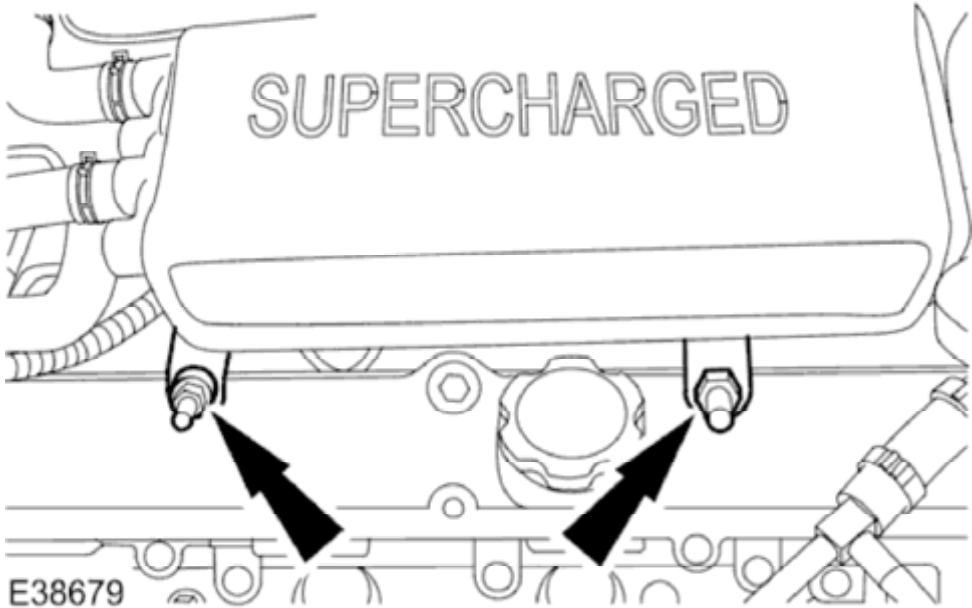

- 6. Attach the fuel injection supply manifold wiring harness retaining bracket.
 - Tighten to 5 Nm.

All vehicles

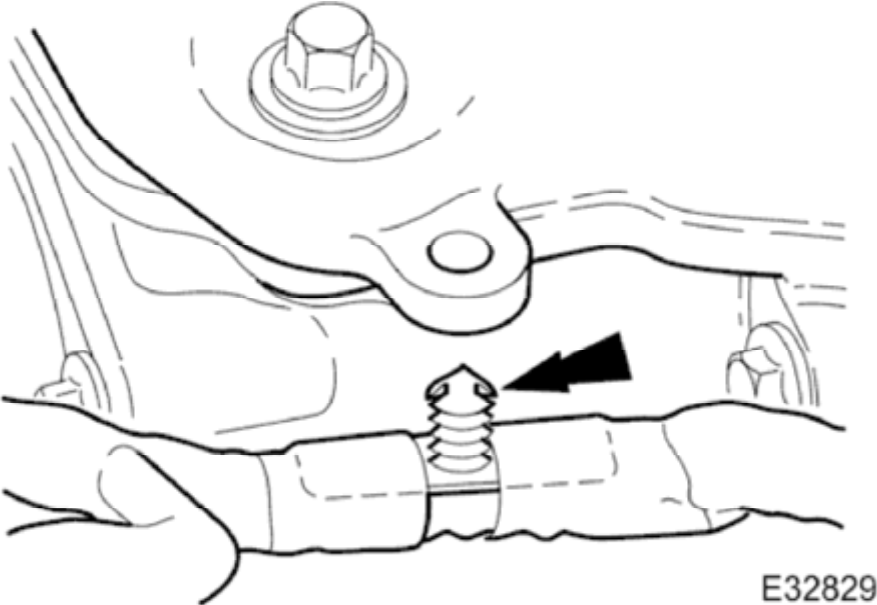

- 7. Reposition the clips which secure the engine harness to the cam cover.

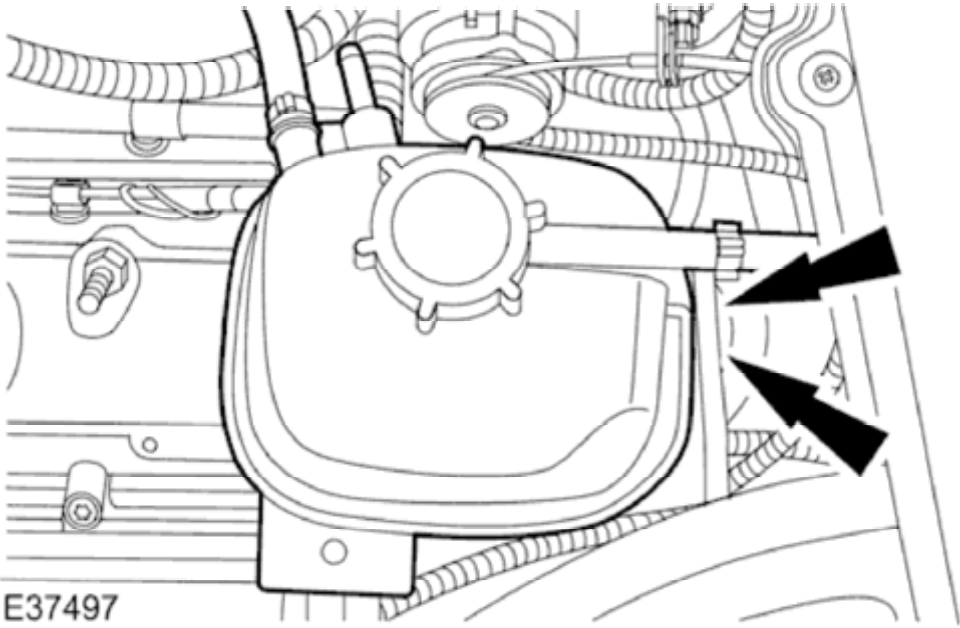

8. Attach the coolant expansion tank.

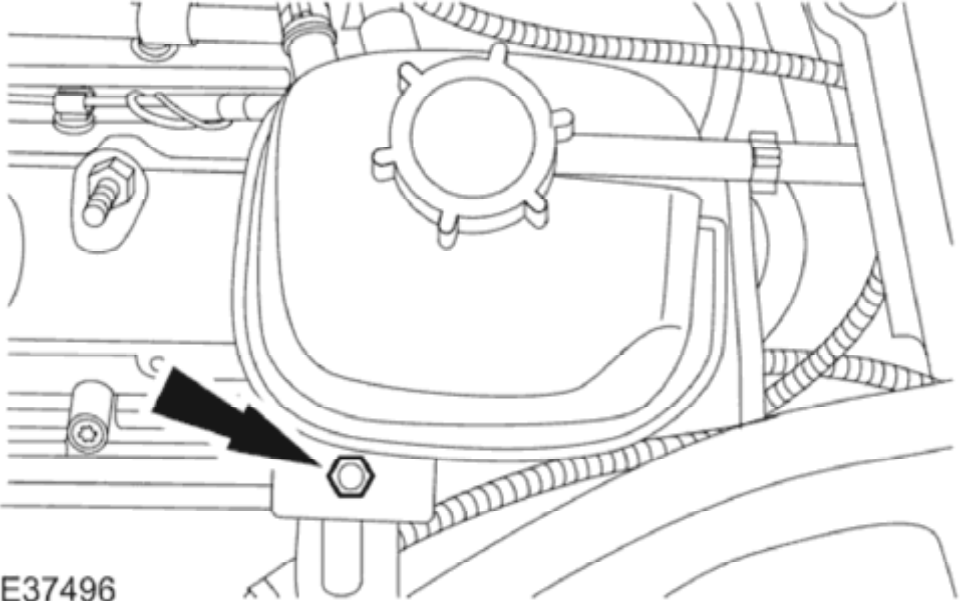

9. Install the coolant expansion tank retaining bolt.
• Tighten to 10 Nm.

1999 XK RANGE - Engine - 303-01

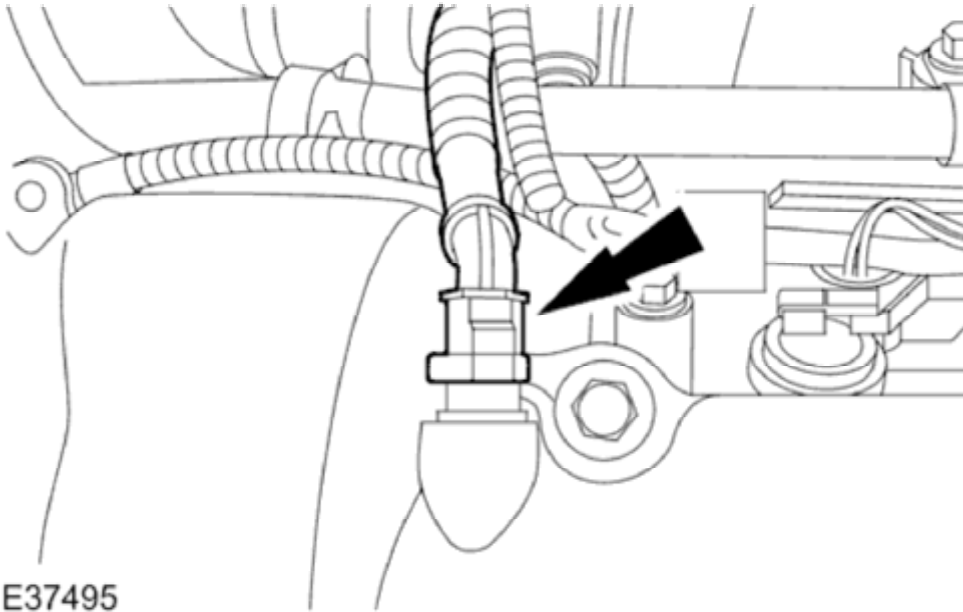

E37495

10. Connect the breather hose to the left-hand valve cover.

11. Install the left-hand ignition coil-on-plugs.<<303-07>>

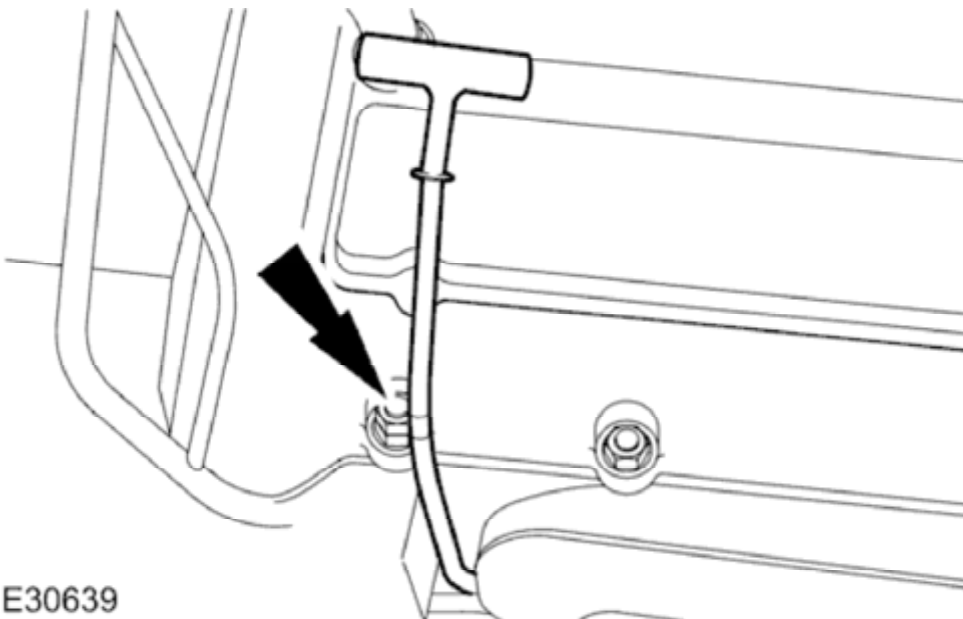

E30639

12. Install the oil level indicator tube.

- Install a new O-ring seal.
- Tighten to 7 Nm.

Vehicles without supercharger

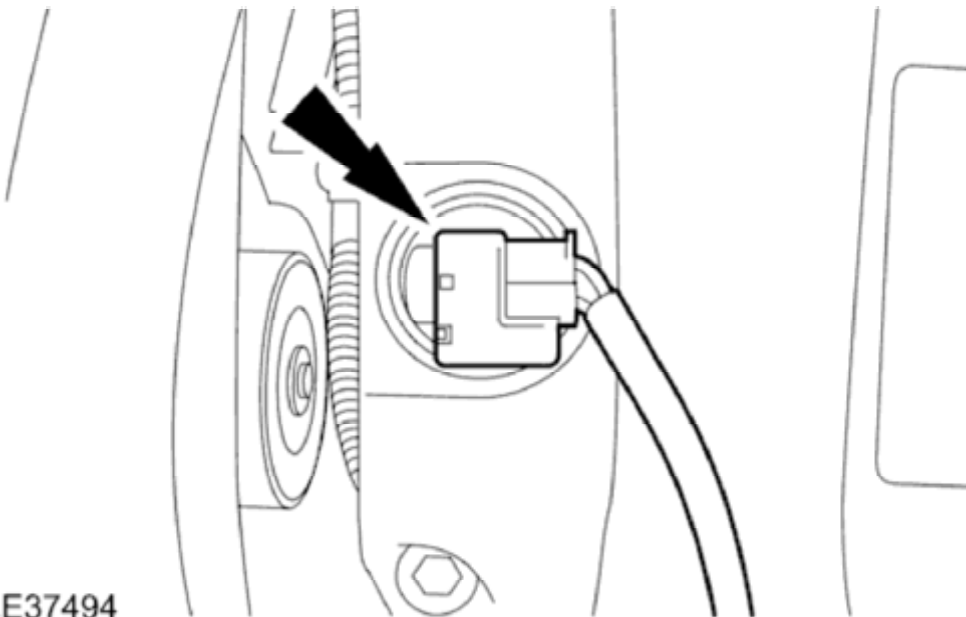

E37494

13. Connect the variable camshaft timing oil control solenoid electrical connector.

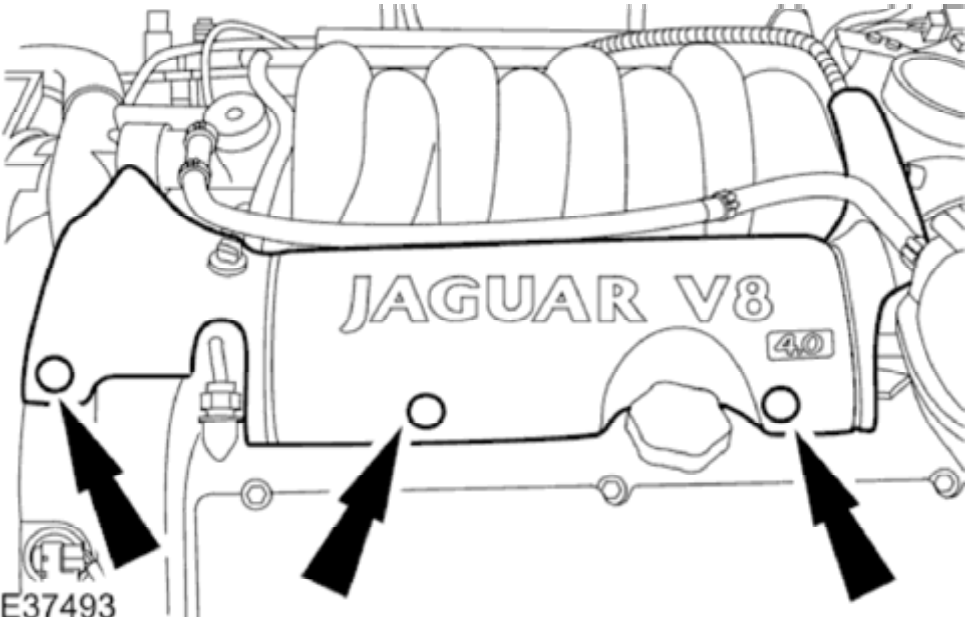

E37493

14. Install the engine left-hand cover.

1999 XK RANGE - Engine - 303-01

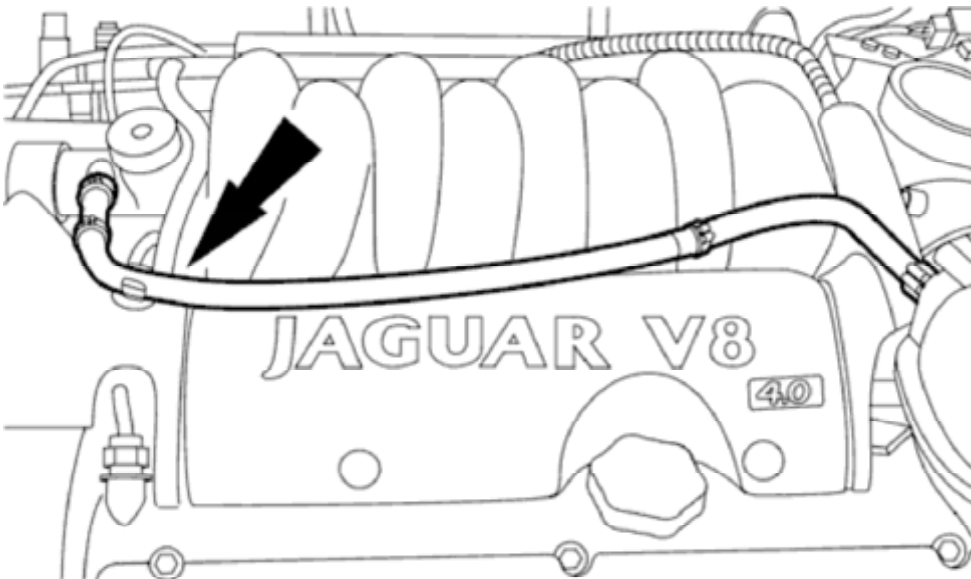

E37492

15. Attach the coolant hose.