



XK

DATE 06/03

307-13

SERVICE

TECHNICAL BULLETIN

Driveline Clunk/Knock When Downshifting –
ZF 6HP26 Automatic Transmission –
Repair ProcedureMODEL 2003 MY-ON
XK Range
VIN A30645-ON**Issue:**

Owners of some 2003 MY-ON XK vehicles, equipped with the ZF 6HP26 automatic transmission, may complain of a driveline clunk/knock when changing from reverse to drive, or while downshifting from fifth to fourth or second to first when the vehicle is slowing.

This complaint can be eliminated by applying Loctite® 648 to the automatic transmission output flange splines.

Action:

in case of a verified customer complaint of the above condition, follow the workshop procedure outlined below.

WORKSHOP PROCEDURE

1. Remove the automatic transmission extension housing seal (see Workshop Manual, JTIS CD ROM, section: 307-01, SRO 44.20.18).
2. Wear clean protective handling gloves and clean the output flange female splines and mating face with Loctite® 7070 ODC-Free Cleaner.

▲ Caution: It is mandatory to wear clean protective handling gloves to prevent re-contamination of the cleaned surface while cleaning the parts and while applying the Loctite®.

3. Clean the transmission output shaft male spline surface with Loctite® 7070 ODC-Free Cleaner.
4. Apply Loctite® 7649 (N) Primer to both female output flange and male output shaft splines according to Loctite® instructions.

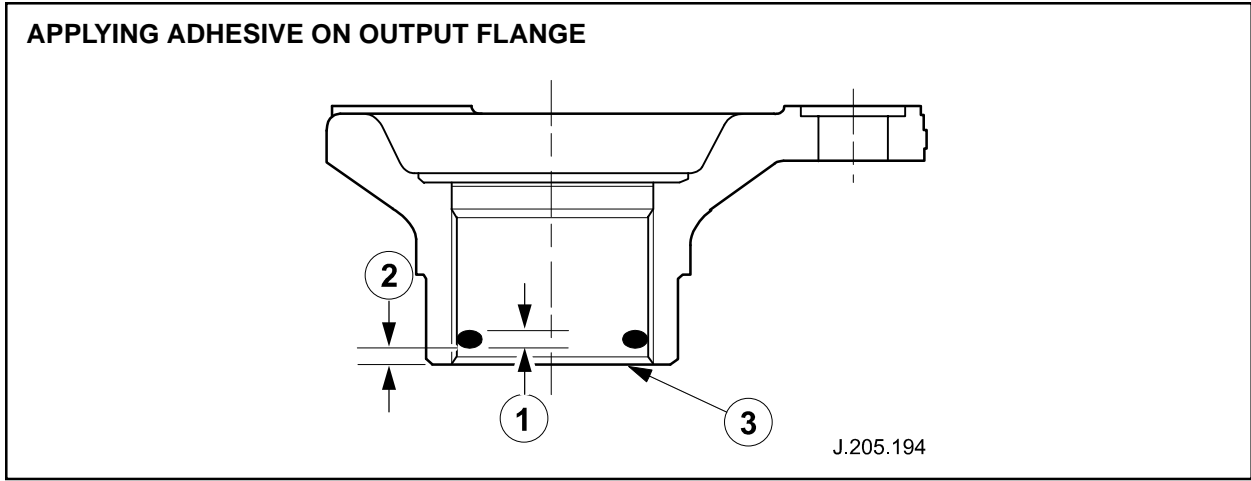

ILLUSTRATION 1

- Apply a 4-5 mm wide bead (1, Illustration 1) of Loctite® 648 adhesive around the female spline of the output flange 3-5 mm (2, Illustration 1) inboard of the entrance chamfer of the spline.

Note: Make sure that there is no adhesive on the front face of the output flange facing the transmission (3, Illustration 1).

- Install the automatic transmission extension housing seal and flange (see Workshop Manual, JTIS CD ROM, section: 307-01, SRO 44.20.18).

Note: After tightening the output shaft flange retaining nut to 60 Nm, stake the nut.

Note: The vehicle must be left for 24 hours at room temperature, without starting the engine, moving the vehicle or disturbing the automatic transmission extension housing output shaft.

Parts Information:

<u>DESCRIPTION</u>	<u>PART NUMBER</u>	<u>QTY</u>
Output shaft oil seal	C2C 6719	1
Locknut	C2C 6725	1

Warranty Information:

Warranty claims should be submitted quoting the information found in the table below. This will result in payment of the stated time and, where applicable parts/miscellaneous expense codes as listed.

<u>MISCELLANEOUS COSTS</u>	<u>SUNDRY CODE</u>	<u>VALUE</u>
Sundry allowance Loctite/cleaner/primer	ZZZ001	\$1.00

<u>Description</u>	<u>SRO</u>	<u>Time</u>	<u>Causal Part Number</u>
Apply Loctite® 648 to the automatic transmission extension housing output shaft splines	44.91.28	2.3 hrs.	C2C 12374