

2002 XK RANGE - Front Suspension - 204-01

Ball Joint 60.15.02

Special Service tools

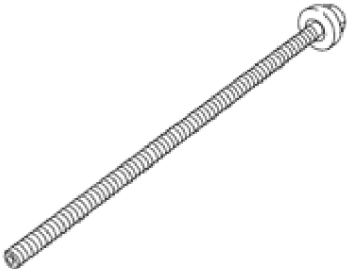

E36462

Ball Joint Taper Separator
204-192 (JD 219)

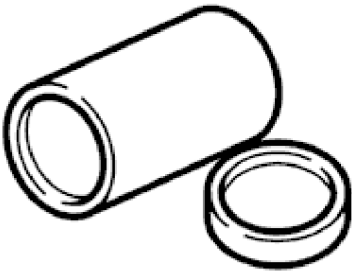

E36426

Upper wishbone ball joint installer.
204-199 (JD239)



E36427

Upper wishbone ball joint remover.
204-200 (JD240)

Removal  CAUTION:

2002 XK RANGE - Front Suspension - 204-01

Replacement of nuts and bolts: Various thread-locking devices are used on nuts and bolts throughout the vehicle. These devices restrict the number of times a nut or bolt can be used. See section <<100-00>> for information.



CAUTION:

The ball joint must be returned for warranty purposes, care must therefore be exercised to avoid damaging it during removal. Any damage incurred during removal must be noted and recorded.

1. Raise front of vehicle and support on stands.
2. Remove appropriate road wheel. Refer to Section <<204-04>>.

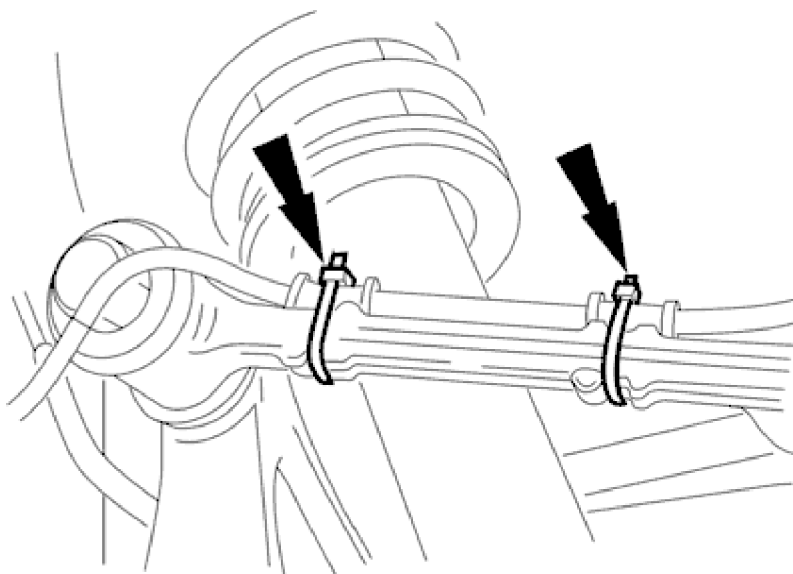

E35045

3. Position wheel speed sensor harness for access.
 - Remove and discard tie straps securing wheel speed sensor harness to wishbone.
 - Position harness clear of wishbone.



E35046

2002 XK RANGE - Front Suspension - 204-01

4. Remove nut securing upper wishbone ball joint to vertical link.
5. Remove tool from ball joint.

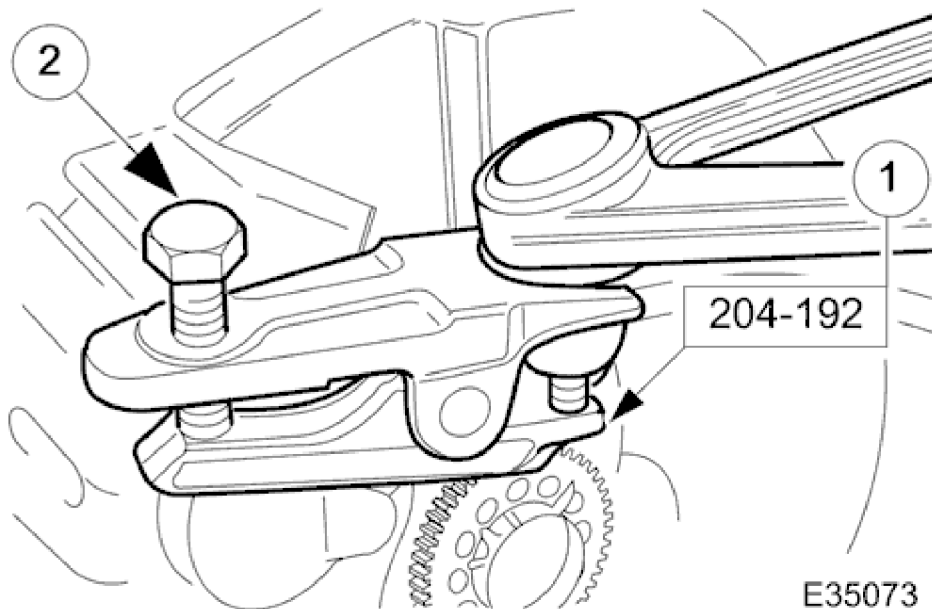

6.  **CAUTION:**
Do not use special tool 211-098 in the following procedure as this will damage the ball joint gaiter.

Release wishbone ball joint from vertical link.

1. Install special tool 204-192 on upper wishbone ball joint.
2. Tighten bolt of special tool to release ball joint taper from vertical link.

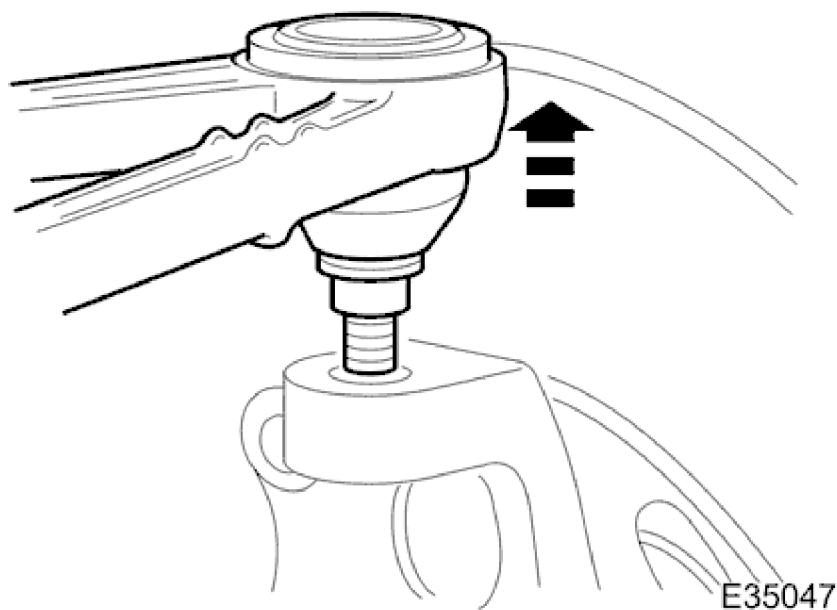

7. Raise upper wishbone to release ball joint pin from vertical link.

2002 XK RANGE - Front Suspension - 204-01

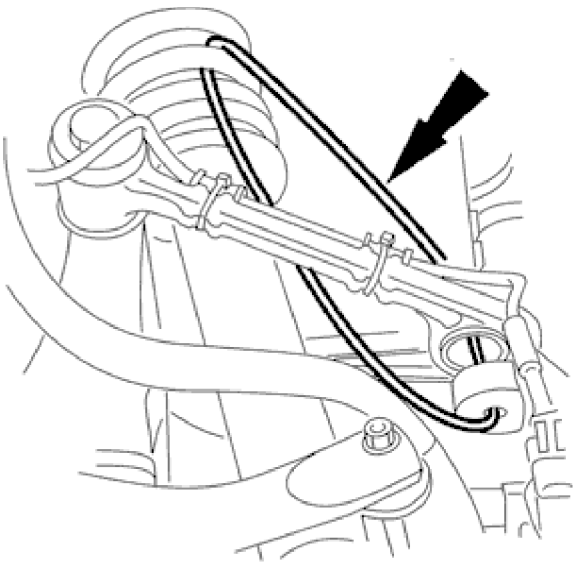

E35038

8. To prevent damage to lower ball joint, secure vertical link to road spring using strong wire.

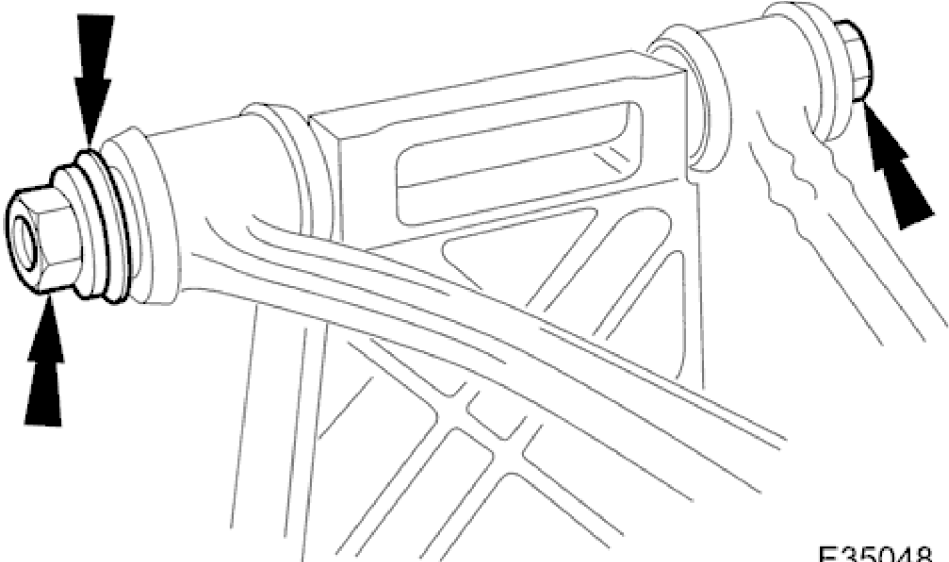

E35048

9. Remove upper wishbone fulcrum nut, washer and shaft.

2002 XK RANGE - Front Suspension - 204-01

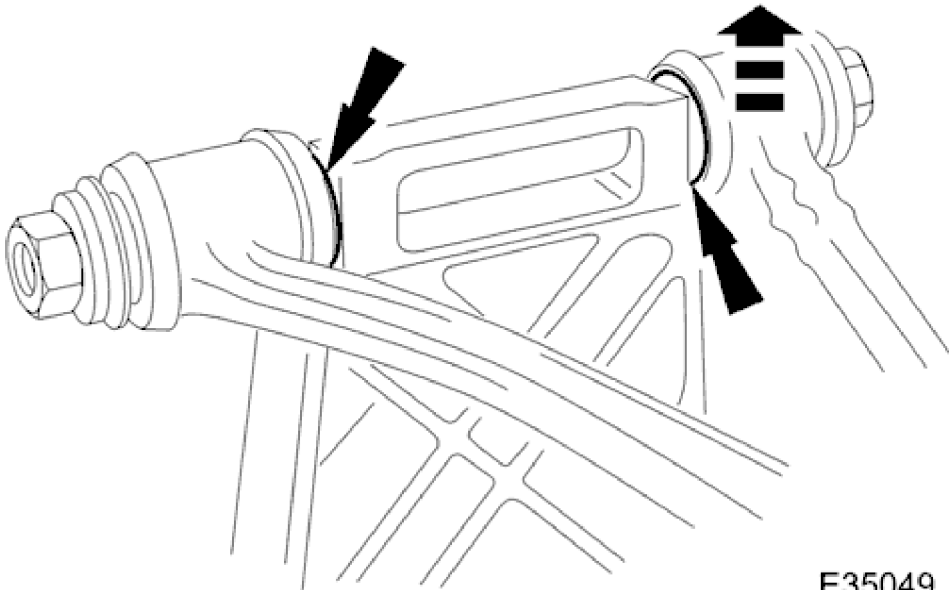

10.  **CAUTION:**
When removing wishbone from suspension beam, retain and note positions of castor adjustment shims.

Remove upper wishbone from suspension beam and retain adjustment shims.

11. Position wishbone in a vise.

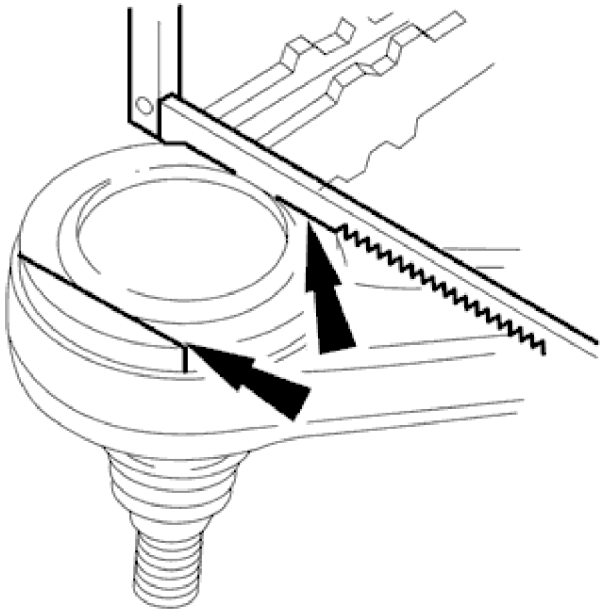

12. Using a hacksaw, partially cut through two diametrically opposite segments of ball joint flange.

2002 XK RANGE - Front Suspension - 204-01

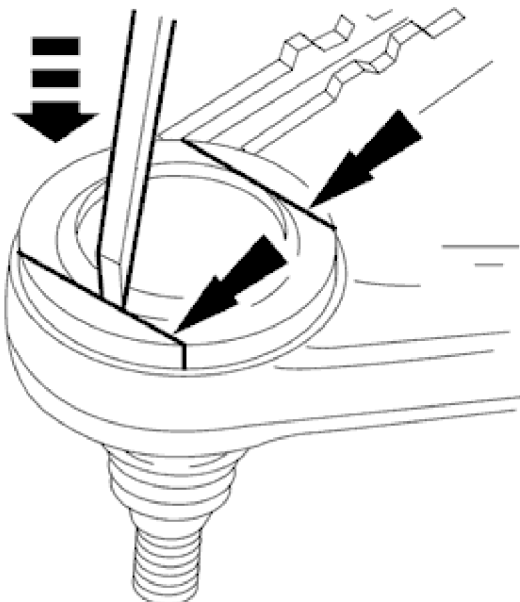

E35051

13. Carefully chisel through and remove the two ball joint flange segments to permit installation between press bed plates.

14. Remove wishbone from vise and thoroughly clean to remove swarf and road deposits.

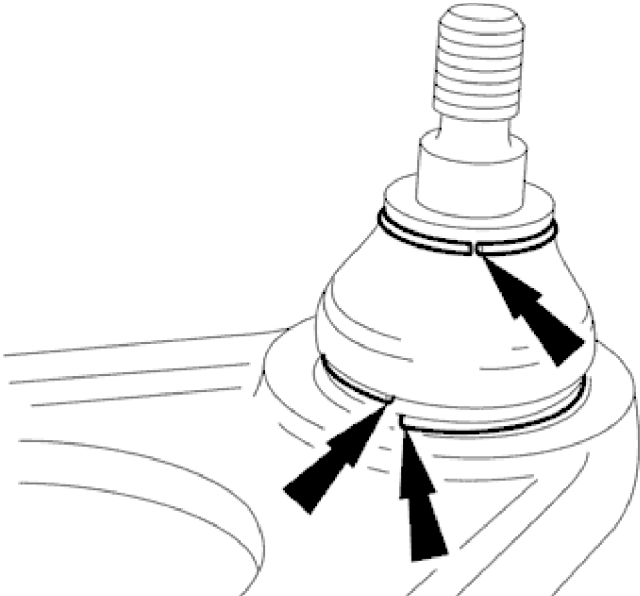

E35052

15. For warranty purposes, paint positions of spring clip ends on ball joint housing and rubber gaiter.

2002 XK RANGE - Front Suspension - 204-01

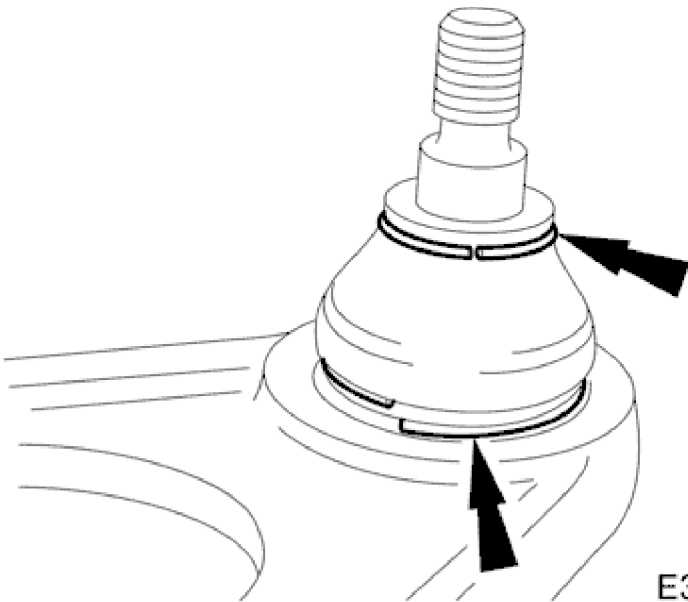

E35053

16. **NOTE:**
Any gaiter damage incurred during removal must be recorded for warranty purposes.

- Remove retaining clips and gaiter.
- Exercising care to avoid splitting or otherwise damaging gaiter, remove retaining clips.
 - Remove gaiter and retain for warranty purposes.

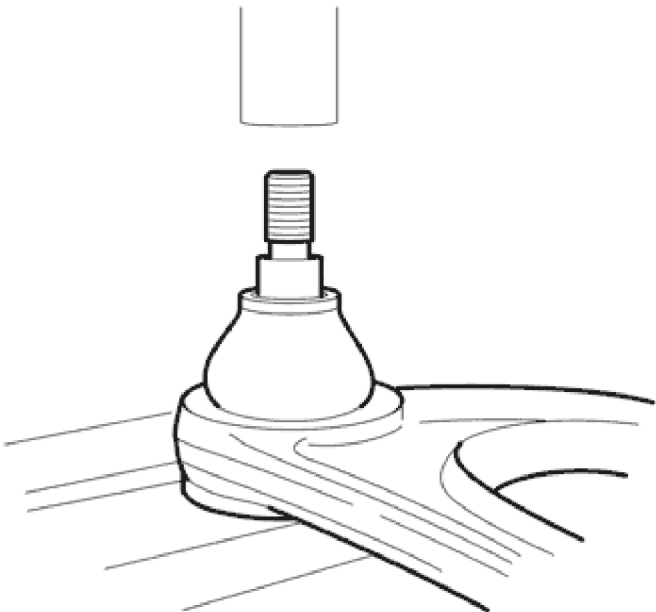

E35054

17. Invert wishbone and position on press with ball joint flange between press bed plates.

2002 XK RANGE - Front Suspension - 204-01

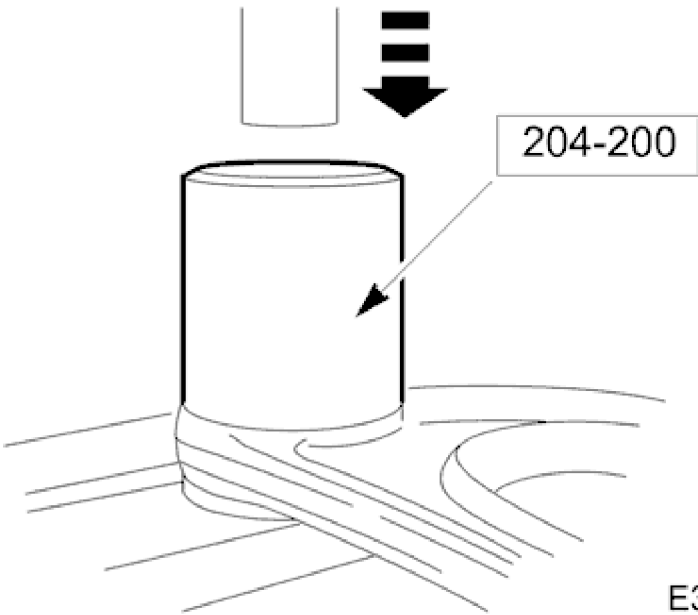

- 18. Install special tool 204-200 on ball joint and operate press to release joint from wishbone.
- 19. Remove special tool from ball joint.
- 20. Remove ball joint and wishbone from press.
- 21. Ensuring that their relative positions are clearly marked, place ball joint, rubber gaiter and retaining clip in a clean plastic bag and return for warranty purposes.
- 22. Thoroughly clean wishbone paying particular attention to ball joint and pivot bolt locations.

Installation

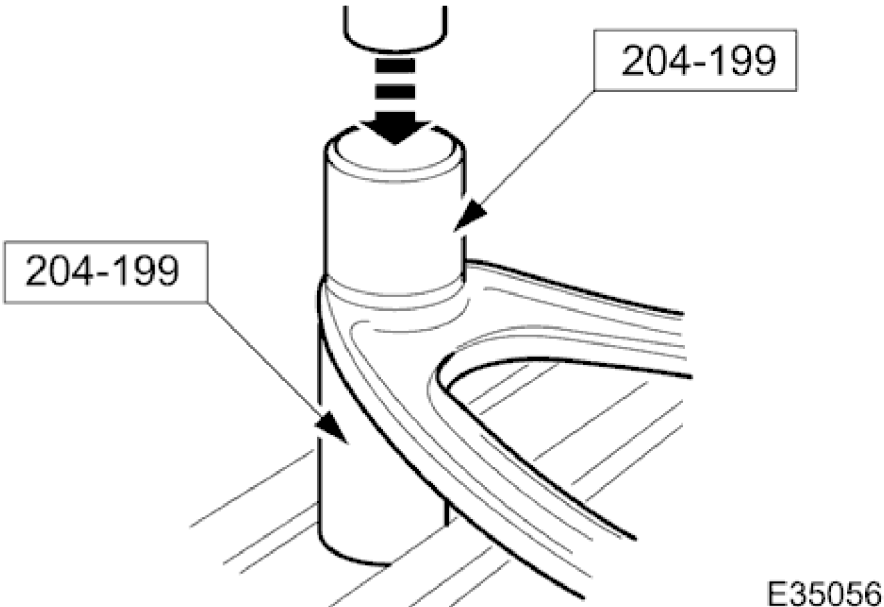

- 1. Install ball joint in wishbone.

2002 XK RANGE - Front Suspension - 204-01

- Position support of special tool 204-199 on press bed and place wishbone on tool.
- Using ball joint plastic cover to align, position mandrel of special tool 204-199 on ball joint
- Align assembly with press ram and operate press to fully seat ball joint in wishbone.

2. Remove tools from ball joint.

3. Remove wishbone from press.

4. Remove and discard plastic cover from ball joint.

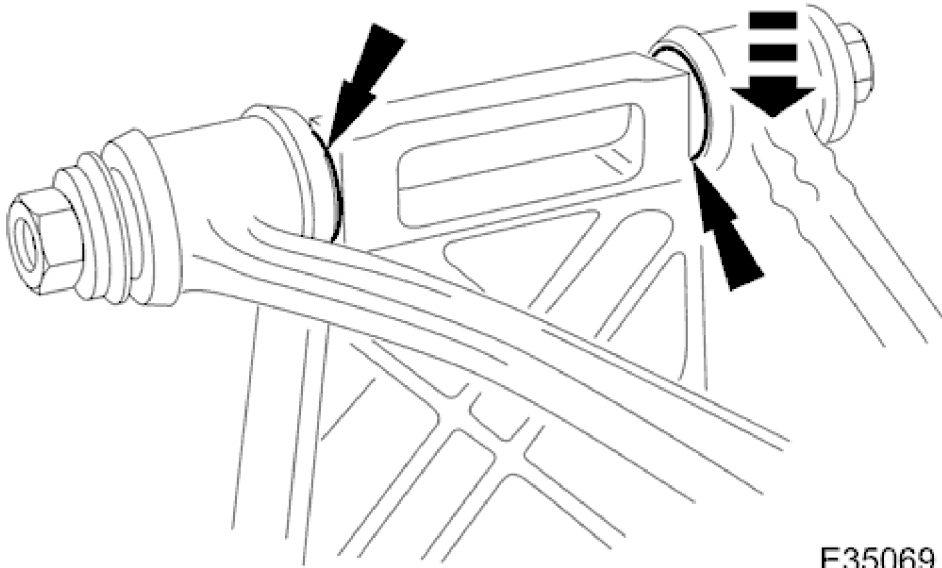

5. Installing castor shims in positions noted during removal, assemble wishbone to suspension beam.

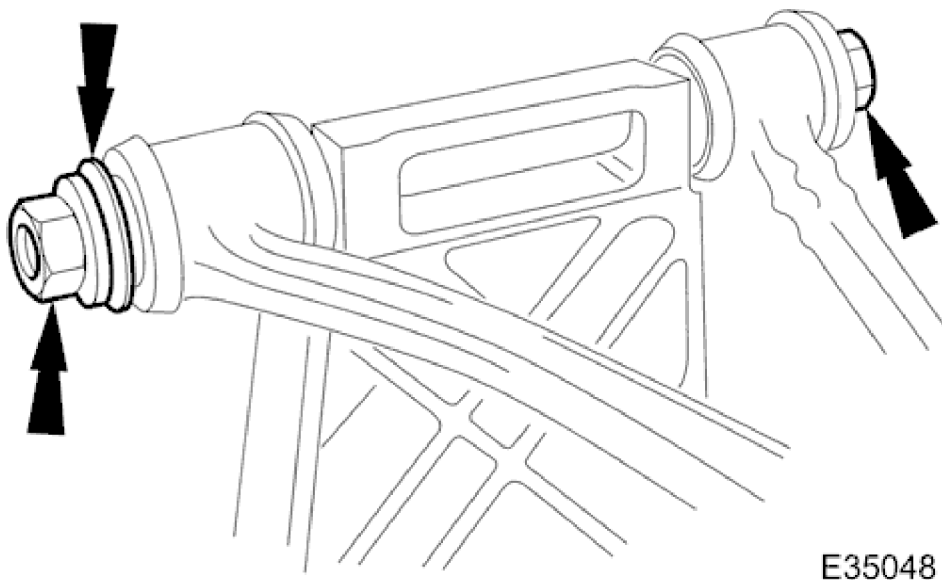

6. Install upper wishbone.

- Install fulcrum shaft thread facing rearward.
- Install washer and nut and tighten nut to 98-132Nm.

2002 XK RANGE - Front Suspension - 204-01

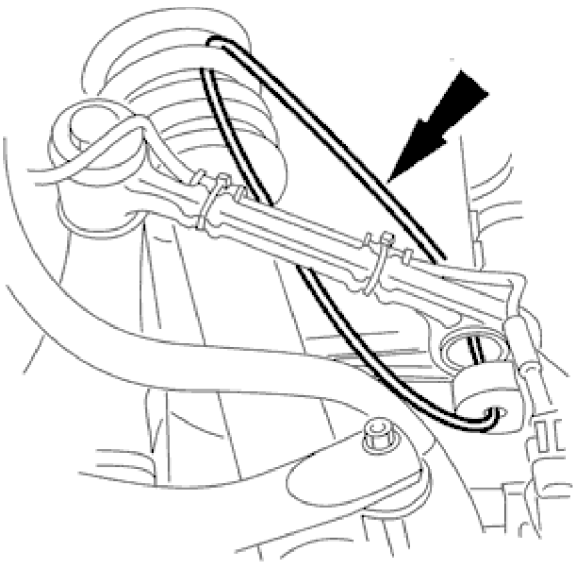

E35038

7. Remove wire/string temporarily securing vertical link to damper.

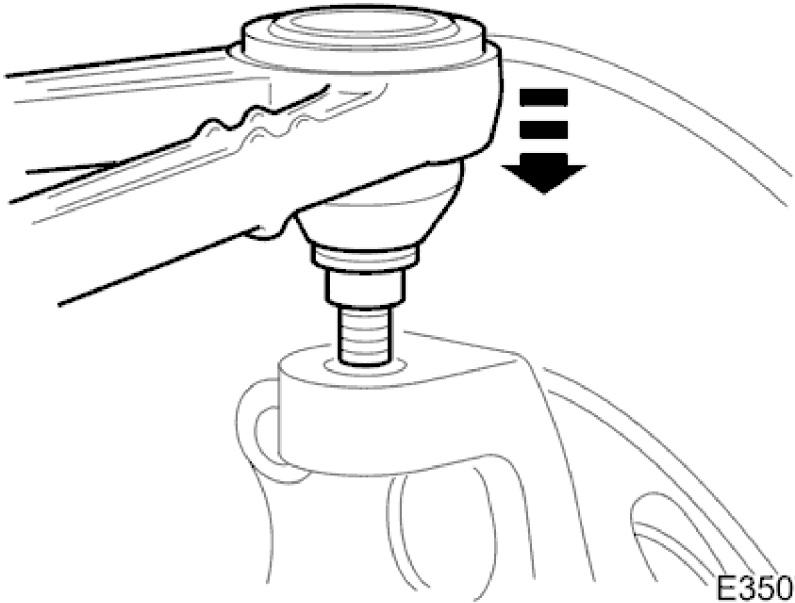

E35070

8. Position wishbone to facilitate engagement of ball joint taper pin in vertical link.

2002 XK RANGE - Front Suspension - 204-01

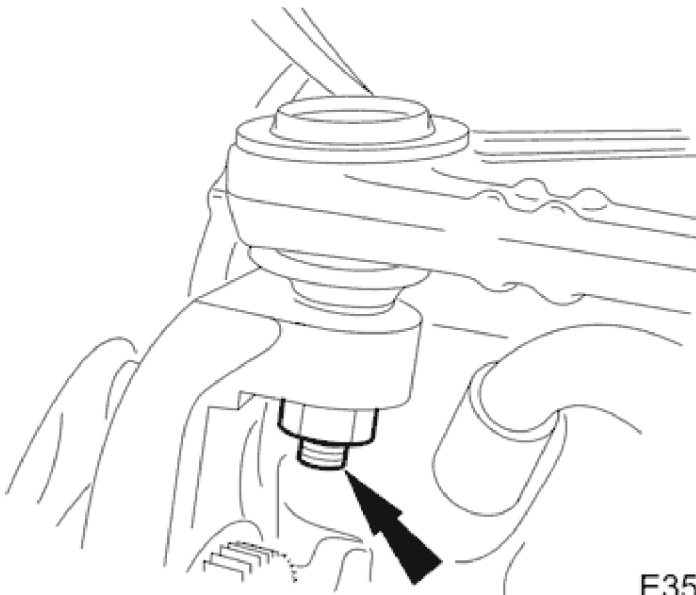

E35046

9. Install nut securing ball joint to vertical link and tighten nut to 60-80Nm.

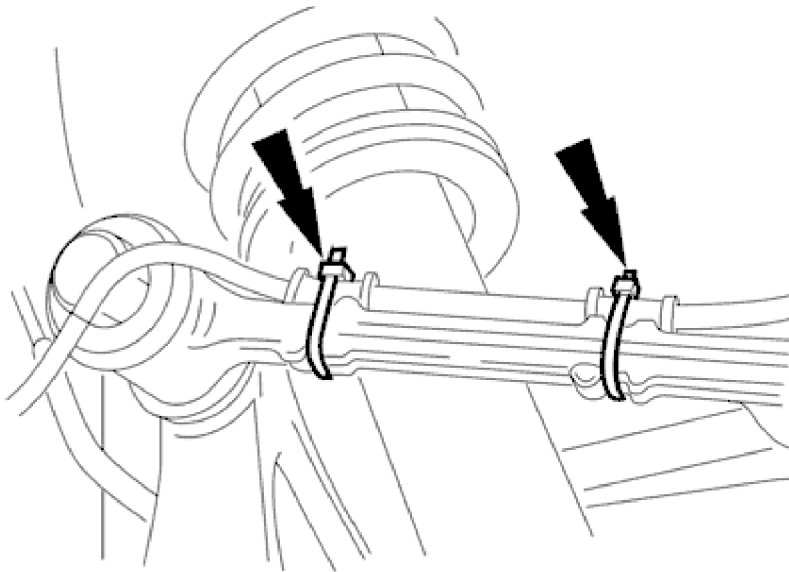

E35045

10. Position wheel speed sensor harness on wishbone and secure with new tie straps.

11. Install road wheel. Refer to Section <<204-04>>.

12. Raise front of vehicle remove stands and lower vehicle.

13. Check and as necessary adjust front wheel alignment. Refer to 57.65.01.



This document was created with the Win2PDF "print to PDF" printer available at <http://www.win2pdf.com>

This version of Win2PDF 10 is for evaluation and non-commercial use only.

This page will not be added after purchasing Win2PDF.

<http://www.win2pdf.com/purchase/>